

C. C. JONES.
 GASOLENE ENGINE.
 APPLICATION FILED OCT. 24, 1908.

963,898.

Patented July 12, 1910.

2 SHEETS—SHEET 1.

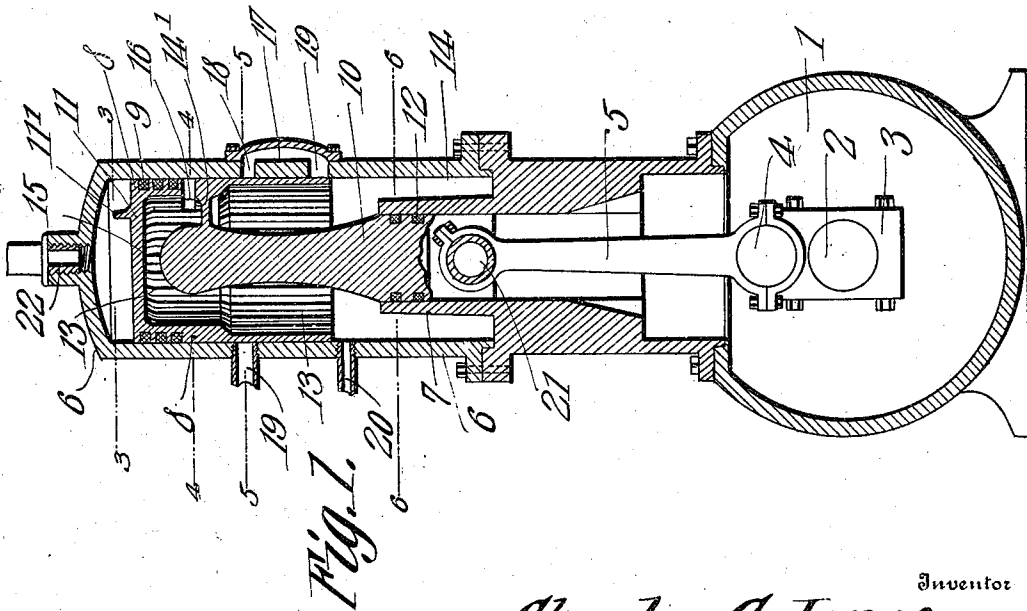
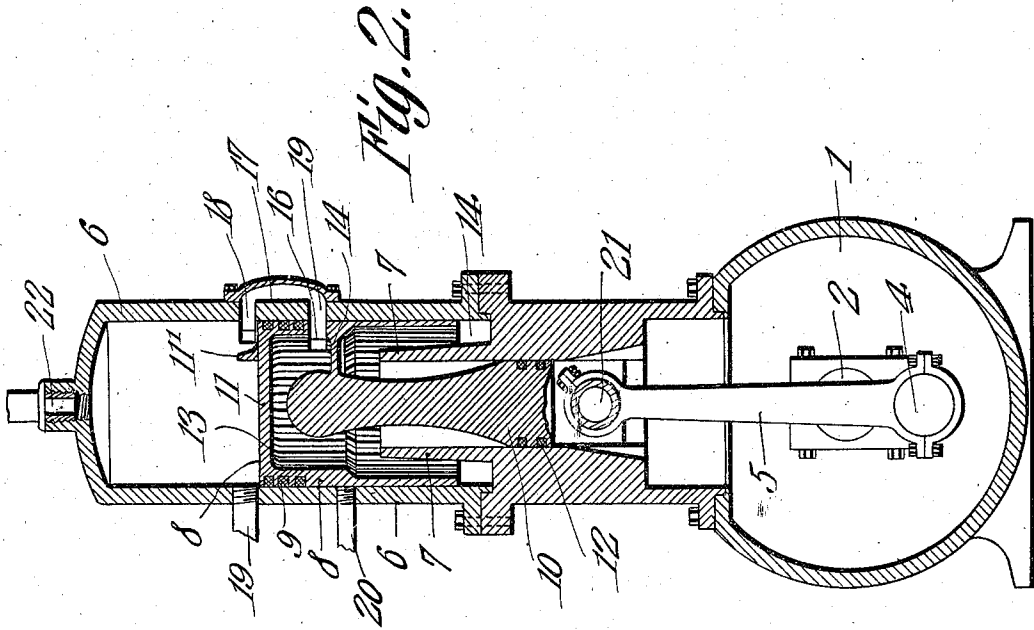

Witnesses

E. J. ...
E. ...

Inventor

Chester C. Jones.

By

C. Snow & Co.

Attorneys

963,898.

Patented July 12, 1910.

2 SHEETS—SHEET 2.

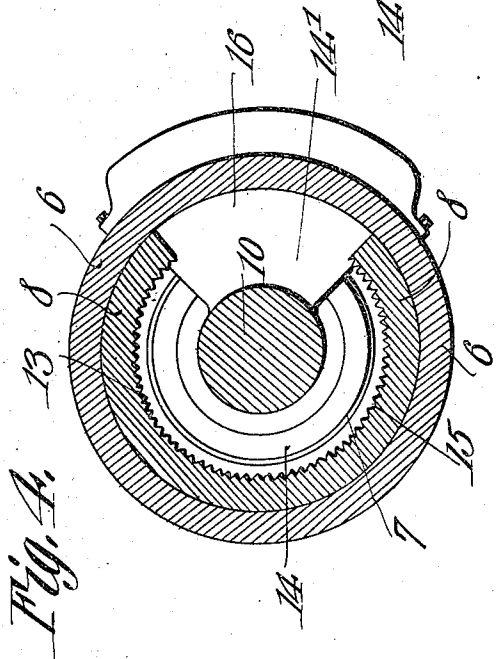
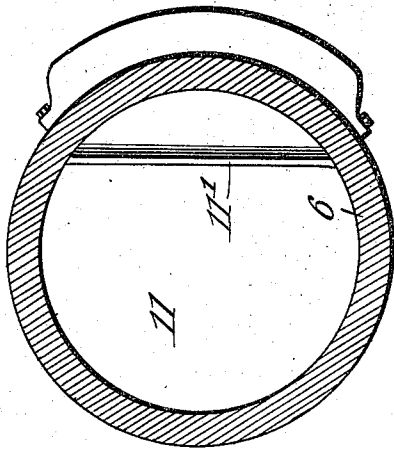
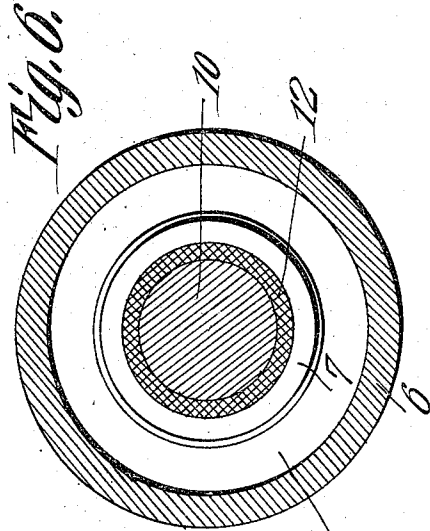
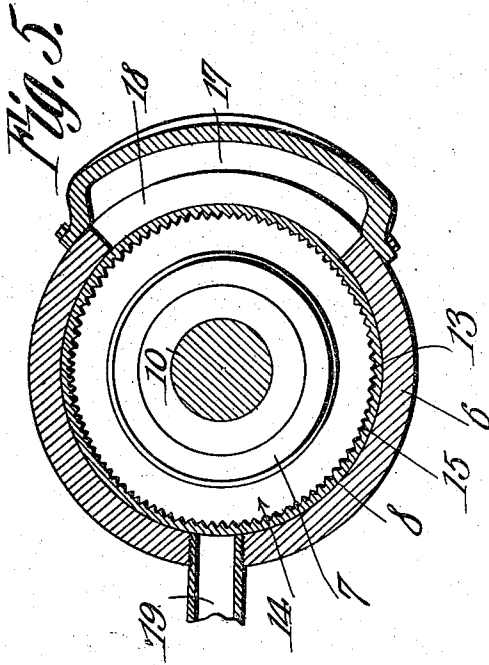

Fig. 3.

Fig. 4.

Witnesses
E. Stewart
C. Daniels

Inventor
Chester C. Jones.

By *Cadnow & Co.*
Attorneys

UNITED STATES PATENT OFFICE.

CHESTER CHARLES JONES, OF BEATRICE, NEBRASKA.

GASOLENE-ENGINE.

963,898.

Specification of Letters Patent. Patented July 12, 1910.

Application filed October 24, 1908. Serial No. 459,361.

To all whom it may concern:

Be it known that I, CHESTER CHARLES JONES, a citizen of the United States, residing at Beatrice, in the county of Gage and State of Nebraska, have invented a new and useful Gasolene-Engine, of which the following is a specification.

My invention relates to internal combustion engines, as gas and gasolene engines; and the objects of my invention are to produce an engine having a superior method of compressing and retaining the explosive charge, and also a superior method of interior cooling for the engine. I achieve these results by the mechanism illustrated in the accompanying drawings, in which—

Figure 1 is a vertical section, showing the piston of the engine at one extremity of its stroke. Fig. 2 is a like vertical section, showing the piston at the other extremity of its stroke. Fig. 3 is a section on the line 3—3 of Fig. 1. Fig. 4 is a section on the line 4—4 of Fig. 1. Fig. 5 is a section on the line 5—5 of Fig. 1, and Fig. 6 is a section on the line 6—6 of Fig. 1.

Similar figures refer to similar parts throughout the several views.

My device, as here illustrated, is a gasolene engine of the two cycle type and referring to the drawings may be described as follows:—

1 is the crank-case, and 2 the engine shaft of the engine.

4 is the crank pin and 5 the connecting rod, having a wrist-pin 21.

8 is a two-part piston, having compression rings 9 on its upper piston head 11.

10 is an auxiliary piston, formed integral with the upper piston-head, and is provided with compression rings 12. It acts as a compression plunger as hereinafter described. Surrounding the piston is a cylinder 6, provided at one end, for a portion of its length with a raised interior wall 7, forming a lower interior compression chamber 14 within the cylinder.

13, 13, are cooling ribs upon the interior surface of the piston, having channels 15 between the ribs through and over which air or other cooling fluid may be forced as hereinafter set forth.

16 is a port in the piston opening to the by-pass 17, in the wall of the cylinder.

18 is the upper port and 19 the lower port

of the by-pass 17; 22 is the spark-plug opening.

19' is an exhaust port; and 20 an intake port, both through the walls of the cylinder.

It will be observed that the lower and auxiliary piston 10, is provided with compression rings 12, the same as the piston head 11; but the walls 7 of its cylinder are contracted so as to allow the upper piston to telescope them, on its downward stroke, thus compressing the gases which have been taken into the chamber at the intake port 20 by the suction stroke, and holding them compressed in the compression chamber 14 until the port 16 opening in the wall of the piston meets the lower port 19 of the by-pass when they are allowed to enter the cylinder above the piston through the upper port 18 of the by-pass 17.

In order to reach the by-pass the compressed gases must pass around one side of the piston across the piston-head 10 and half way down on the other side to the opening 16, in the wall of the piston.

The piston has a partition 14' with an opening only on the opposite side from the port-opening 16. This forces the mixture of gas and air by the route described and it will be observed that the annular compression chamber is entirely closed below the inlet port 20 so that the gas cannot escape therefrom and the compression will be thorough.

Formed on the interior of the piston, preferably longitudinally thereof, are cooling-ribs 13 and channels 15 between the ribs for the passage of a cooling fluid, as air, or air and gas. In operation every impulse throws the fresh air and gas around the inner walls of the piston with such velocity that the piston is cooled.

What I claim and desire to secure by Letters Patent of the United States is:—

A hydrocarbon engine comprising concentric cylinders forming an annular compression chamber closed except at its upper end, an intake in the outer cylinder above the upper end of the inner cylinder, an exhaust in the side of the outer cylinder, a by-pass disposed longitudinally on the side of the outer cylinder with its ends between the planes of the intake and the exhaust, concentric pistons arranged within the cylinders, the upper end of the outer piston being above

and spaced from the upper end of the inner piston, and a transverse partition connecting the upper end of the inner piston with that side of the outer piston moving over the by-pass, the outer piston being provided with a port above said partition adapted to register with the ends of the by-pass.

In testimony that I claim the foregoing as my own, I have hereto affixed my signature in the presence of two witnesses.

CHESTER CHARLES JONES.

Witnesses:

H. E. SACKETT,

CHAS. L. BREWSTER.