

E. MAIGROT & J. SABATES.

APPARATUS FOR THE DEFECCATION OF SACCHARINE JUICES BY ELECTRICITY IN THE MANUFACTURE OF SUGAR.

No. 455,631.

Patented July 7, 1891.

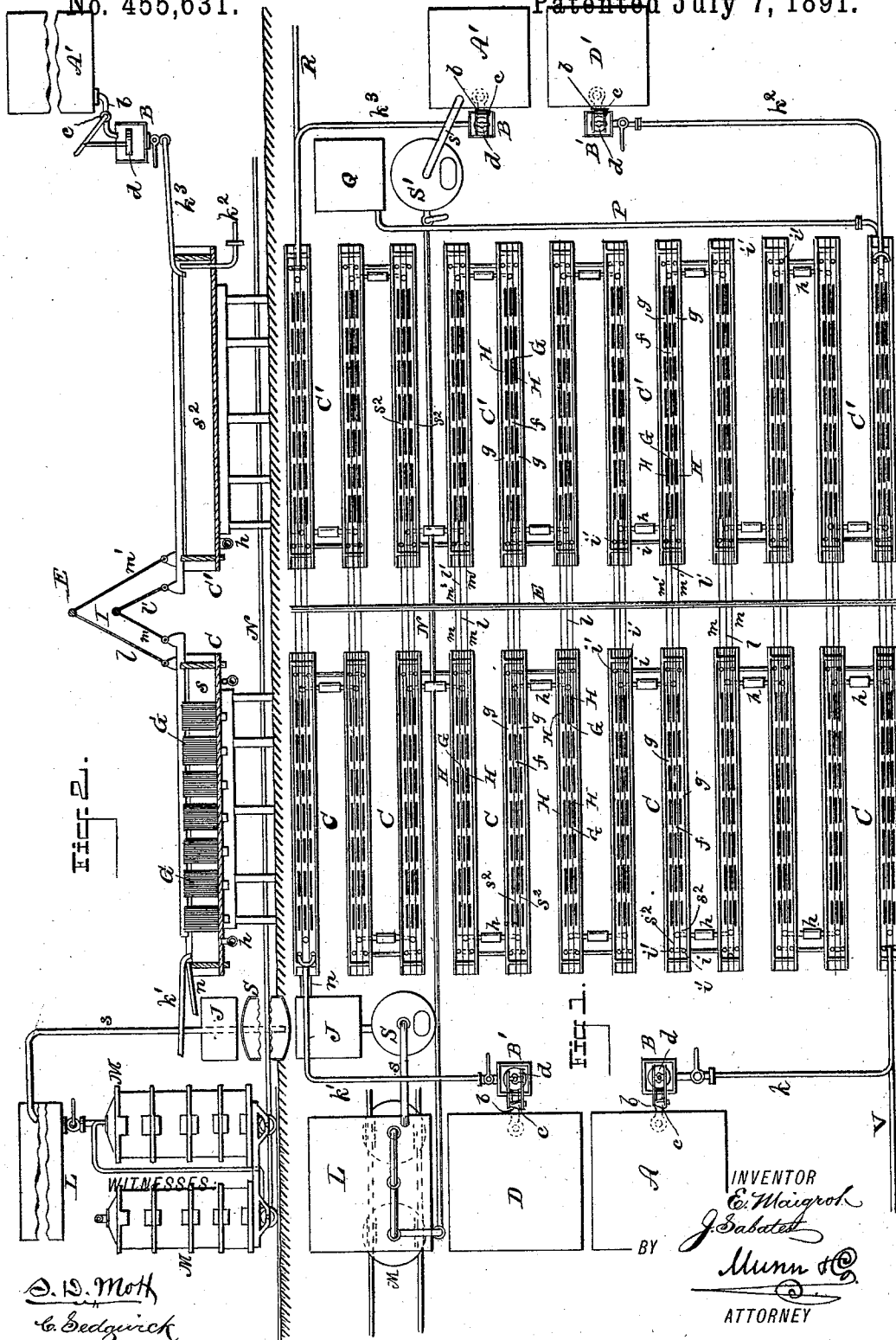

D. S. Mott
G. Bedgwick

INVENTOR
E. Maigrot
J. Sabates
BY
Munn & Co.
ATTORNEY

(No Model.)

3 Sheets—Sheet 2.

E. MAIGROT & J. SABATES.

APPARATUS FOR THE DEFECTION OF SACCHARINE JUICES BY
ELECTRICITY IN THE MANUFACTURE OF SUGAR.

No. 455,631.

Patented July 7, 1891.

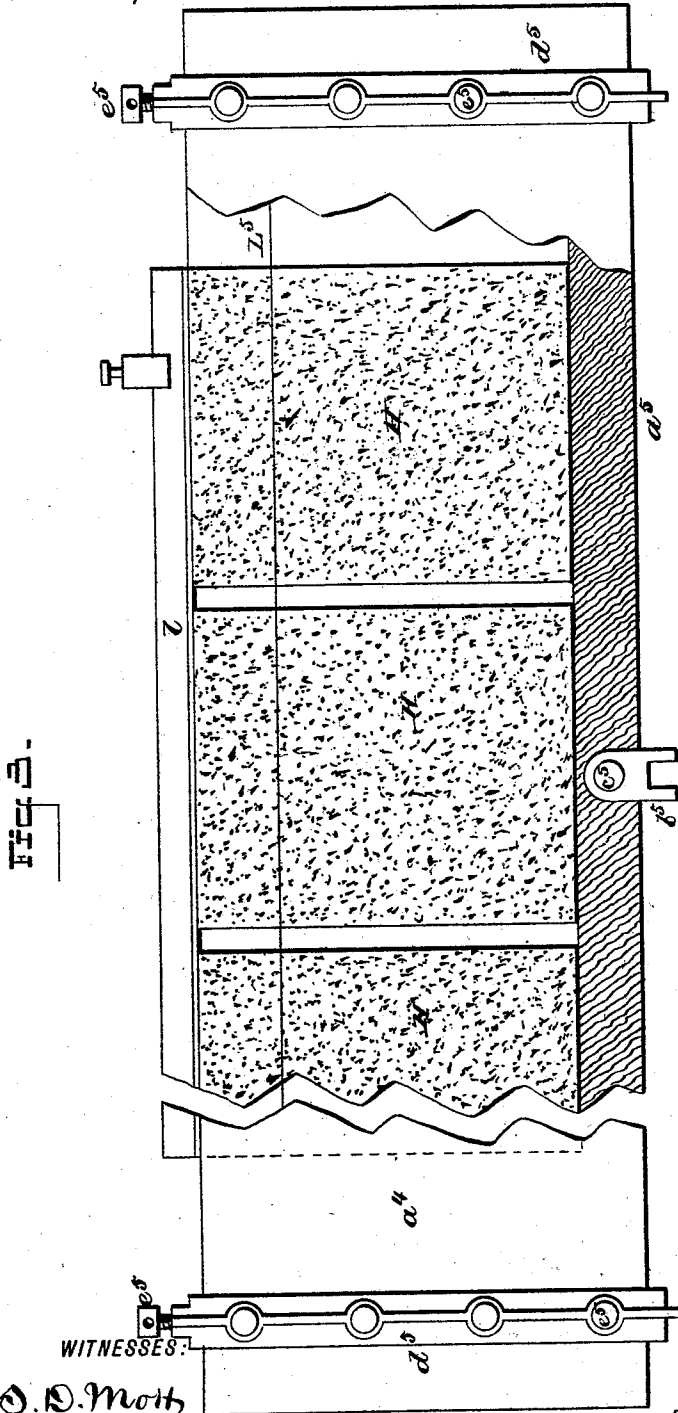

Fig. 2.

WITNESSES:

D. D. Moth
C. Beckwith

INVENTOR
E. Maigrot
BY J. Sabates
Munn & Co.
ATTORNEY

E. MAIGROT & J. SABATES.

APPARATUS FOR THE DEFECTION OF SACCHARINE JUICES BY ELECTRICITY IN THE MANUFACTURE OF SUGAR.

No. 455,631.

Patented July 7, 1891.

FIG. 5.

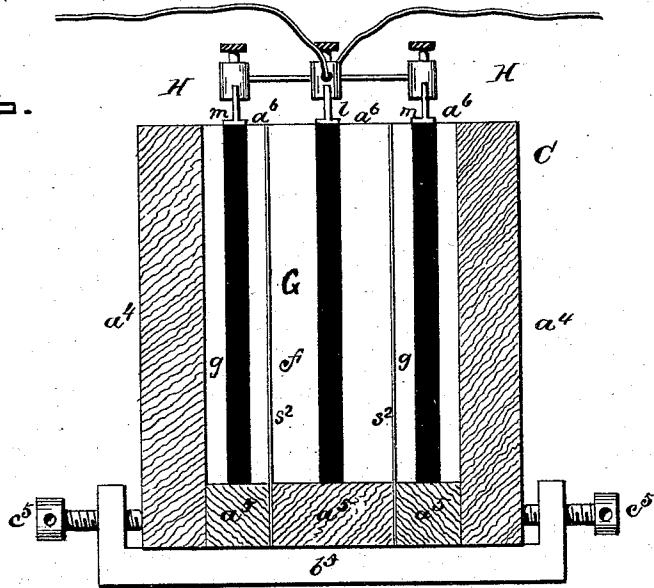
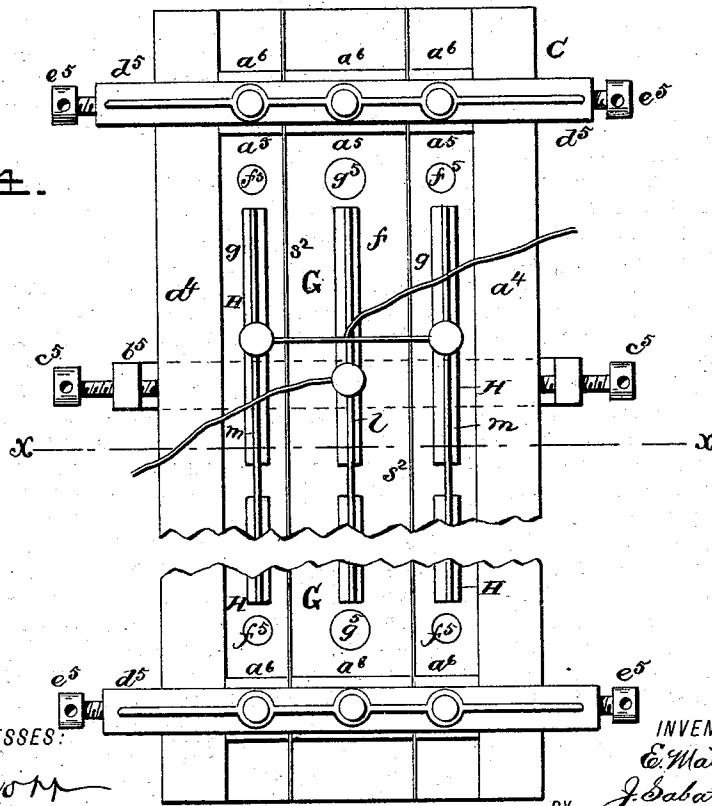

FIG. 4.



WITNESSES:

D. D. Mott
C. Sedgwick

BY

INVENTOR

E. Maigrot
J. Sabates

ATTORNEY

UNITED STATES PATENT OFFICE.

ELIAS MAIGROT AND JOSÉ SABATES, OF HAVANA, CUBA.

APPARATUS FOR THE DEFECTION OF SACCHARINE JUICES BY ELECTRICITY IN THE MANUFACTURE OF SUGAR.

SPECIFICATION forming part of Letters Patent No. 455,631, dated July 7, 1891.

Application filed April 15, 1889. Serial No. 307,305. (No model.)

To all whom it may concern:

Be it known that we, ELIAS MAIGROT and JOSÉ SABATES, of Havana, Cuba, have invented new and useful Improvements in Apparatus for the Defecation of Saccharine Juices by Electricity in the Manufacture of Sugar, of which the following is a full, clear, and exact description.

This invention relates to apparatus for the defecation of saccharine juice for the purpose of obtaining an increased yield of pure prismatic sugar therefrom by subjecting the saccharine juices to the action of electric currents, which operate to decompose, alter, transfer, and remove from said juices the alkaline salts, acids, and albuminous and other deleterious substances that prevent or interfere with the crystallization of the sugar; and our invention consists in an apparatus of special construction for such purposes, embracing various novel and improved combinations of parts, substantially as hereinafter described, and pointed out in the claims, whereby the desired results are very perfectly secured.

Reference is to be had to the accompanying drawings, forming a part of this specification, in which similar letters of reference indicate corresponding parts in all the figures.

Figure 1 represents a plan view of so much of our apparatus as is necessary to illustrate the invention; Fig. 2, a sectional elevation of the same in line with the electrolyzing troughs or canals of the apparatus; and Fig. 3 is a broken and partly-sectional longitudinal elevation, upon a larger scale, of one of the electrolyzing-troughs with electrodes therein, mainly in illustration of the preferred construction of said troughs and of the means used to clamp the same and to secure the septums or diaphragms which divide each of said troughs into separate longitudinal compartments in which the carbon electrodes are arranged. Fig. 4 is a broken plan view of the same, and Fig. 5 vertical transverse section thereof upon the line $x x$ in Fig. 4.

In carrying out our invention we employ series of horizontal electrolyzing troughs or canals $C C' C'$, arranged in two groups, the troughs of each group being preferably arranged parallel with each other, as shown in

Fig. 1. Each trough is constructed of wood or other suitable material, the side pieces a^4 being clamped to the edges of the bottom pieces a^5 and end pieces a^6 by the clamps b^5 arranged at suitable intervals, and furnished with screws c^5 , which bear against the side pieces. The bottom of the trough is formed of thin strips a^5 , the center strip being twice as wide as the outer strips. In a similar way the ends of the trough are formed of strips a^6 . Between the central strip and the outside strips a^5 are clamped septums s^2 of parchment paper, which extend throughout the entire length of the trough and divide it into three longitudinal compartments $f g g$. In the central compartment f is arranged a series of carbon electrodes G , connected by wires l with a conductor E , leading to the positive pole of a dynamo-electric machine. In a similar way carbon electrodes H are arranged in the outer compartments $g g$ of the trough and connected by wires m with the conductor I , leading to the negative pole of the dynamo-electric machine.

The troughs C are arranged parallel with each other in a horizontal plane, and are connected alternately at opposite ends by two series of pipes h being inserted in apertures g^5 in the bottom of the troughs, and pipes $i i'$, the pipes h serving to connect the central compartments f of adjacent troughs, while the pipes $i i'$, inserted in apertures f^5 in the bottom of the troughs, connect the outer compartments $g g$, so that the entire series of troughs form practically one trough equal in length to the combined lengths of all of the troughs of the series. In like manner a second series of similar troughs C' is arranged in the same plane with the electrodes and connections like those already described.

Near the first series of troughs C is placed a tank A , which is elevated above the plane of the troughs C and provided with a discharge-pipe b , furnished with a lever-cock c , the said discharge-pipe b being arranged to discharge into a receptacle B , placed below the pipe b and above the plane of the troughs C . The receptacle B discharges through a pipe k into the central compartment of one of the terminal troughs of the series C . The

said pipe k is provided with a stop-cock of ordinary construction for regulating the flow of liquid through the pipe. A similar tank A' is arranged in the same manner in connection with the series of troughs C' , a receptacle B being arranged to discharge into the first of the series of troughs C' , and it is in connection with the tank A' , as shown in Fig. 2, that the construction of the tank A , receptacle B , and regulating devices is most clearly shown.

A tank D , adjoining the tank A , is arranged to discharge into the receptacle B' , which in turn discharges through the forked pipe k' into the compartments g of the trough C at the end of the series opposite that which receives the discharge of the pipe k . In the same way a tank D' is arranged to discharge into a receptacle B' , which in turn feeds through the pipe k^2 into the compartments g of the terminal trough C' of the second series.

All of the carbon plates H in the outer compartments g of the first series of troughs C are connected electrically by wires m with the negative conductor I , leading to the negative pole of the dynamo, and all the carbon plates G in the central compartments f of the first series of troughs C are connected by wires l with the conductor E , leading to the positive pole of the dynamo. The carbon plates H G of the second series of troughs are connected in the reverse order with the conductors E I by wires m' l' .

The saccharine juice to be treated is placed in the tank A , whence it flows through the pipe b and lever-cock c to the receptacle B . In the receptacle B is a float d , furnished with a rod, which is pivotally connected with the lever of the cock c . The flow of the juice from the receptacle B through the pipe k is controlled by the cock in the said pipe, so that a uniform level of the juice is maintained in the central compartments of the troughs C , the juice being supplied as fast as it flows away by gravity. The uniformity of the supply is secured by maintaining a uniform head in the receptacle B by means of the float d and lever-cock c , the rise or fall of the float acting on the lever-cock to close or open it, or hold it in one position, whichever may be necessary to maintain a uniform head and consequent uniform discharge from the receptacle. The reservoir D supplies water to the compartments g in the same manner. The water enters one end of the series of troughs C and the saccharine juice is supplied to the other end. The two liquids pass in opposite directions in the troughs and are each delivered at the end of the series of troughs opposite that at which they entered.

The saccharine juice, after the electrical treatment presently to be described, is discharged through the pipe n into the tank J , from whence it is drawn periodically into the closed vessel S , in which is produced by any well known means an air-pressure sufficient

to cause the juice to rise through the pipe s and discharge into the tank L . From this tank the juice is allowed to flow through the filters M M , thence through the pipe N to the closed vessel S' , adjoining the series of troughs C' . The juice is periodically shut in the vessel S' and forced upward by air-pressure through the pipe s' and discharged into the tank A' . From this tank the partially-treated juice is allowed to flow in a regulated stream into the receptacle B in the manner already described, and from the receptacle B the juice flows through the pipe k^3 to the central compartment f of the first of the troughs C' of the second series, whence it passes through the entire series, as in the case first described, the juice being finally discharged into the tank Q , ready for further treatment according to well-known processes. The water admitted to the first series of troughs C through the pipe k' is discharged through the pipe V at the other end of the series, and is conveyed away for treatment for the recovery of the matter derived from the juice. In a similar way the water supplied to the troughs C' is conveyed away through the pipe R .

The saccharine juice and the water being in circulation in the troughs CC' , as stated, and the electric current being supplied to the carbon plates G H in the manner already described, the electrolytic action is as follows: Oxygen is separated in the compartment f by the decomposition of the water contained in the saccharine juice, and hydrogen is liberated by the decomposition of the water surrounding the negative electrode, water in its natural state having sufficient electrical conductivity to start the process. The mineral salts contained by the saccharine juice, such as the salts of potassium, sodium, magnesium, and calcium, are decomposed by electrolytic action, the acids seeking the positive pole, the bases being transferred through the parchment-paper septum to the negative pole, while the protein and peptic substances which existed in the solution remain in solution in the juice until they are transformed by the ozonized oxygen liberated by the decomposition of the water into insoluble fibrine, which is removed by filtration after passing the first series of troughs. During the first step in the process the juice receives all its electro-chemical treatment. The passing of the juice through the second series of troughs is designed to separate the organic acids from the juice by an electro-dynamic operation, the current passing in the opposite direction through the electrodes of the second series of troughs C' —*i. e.*, the electrodes in the outer compartments are positive and those in the central compartment are negative. The current under these circumstances transfers the acids from the juice in the central compartment to the water in the outer compartments.

The juice is discharged from the apparatus in a neutral state and is in suitable condition for evaporation.

Having thus described our invention, what we claim as new, and desire to secure by Letters Patent, is—

1. In apparatus for the defecation of saccharine juices by electrical currents in the manufacture of sugar, the combination of a series of troughs provided with longitudinal porous partitions dividing the troughs into longitudinal compartments, connecting-pipes connecting the two sets of compartments in two separate series, one series for the circulation of water upon one side of each porous partition, the other for the circulation of saccharine juices on the opposite side of the porous partition, and electrodes suspended in the compartments and connected with an electric generator, substantially as specified.

2. In apparatus for the defecation of saccharine juices by electrical currents in the manufacture of sugar, the combination, in a group, of a series of troughs each divided vertically by septums into a central compartment for the saccharine juices or solution and into lateral or outside compartments for water, circulating connections between the several central compartments, and separate circulating connections between the lateral compartments throughout the whole series of troughs, and positive and negative electrodes arranged within said central and lateral compartments, respectively, substantially as specified.

3. In apparatus for the defecation of saccharine juices by electrical currents in the manufacture of sugar, the combination of independent groups of troughs, each trough of either series being divided vertically by septums into a central compartment for the saccharine juices or solution and into lateral compartments for water, circulating connections between the several central compartments in each group of troughs, and separate circulating-connections between the several lateral compartments thereof, a series of positive electrodes within the central compartments of the one group of troughs, a series of negative electrodes within the lateral compartments of the same troughs, and a series of negative electrodes within the central compartments of the other group of troughs, a series of positive electrodes within the lateral compartments of the last-named group of troughs, connections for establishing communication between the two series of troughs, and elevated tanks for supplying saccharine juices and water to the two series of troughs, essentially as and for the purposes herein set forth.

4. In apparatus for the defecation of saccharine juices by electrical currents in the manufacture of sugar, the troughs C, divided into separate compartments by porous sep-

tums capable of permitting of the passage of the electric currents through them, and constructed with side walls and base and end clamping blocks or pieces adapted to hold said septums in between them, in combination with fastenings operating to bind the septum-clamping blocks and septums to their places, substantially as specified.

5. The combination, with the side walls a^4 of the troughs, of the clamping base blocks or pieces a^5 , the clamping end blocks or pieces a^6 , the septums s^2 , and the clamp $b^5 d^5$, essentially as described.

6. The combination, with the side walls a^4 of the troughs, of the clamping base blocks or pieces a^5 , the clamping end blocks or pieces a^6 , the septums s^2 , and the head or end strap-like clamps d^5 , provided with binding-screws e^5 , substantially as specified.

7. In apparatus for the defecation of sugar, as described, the combination, with the independent groups C C' of vertically-divided troughs, with their positive and negative electrodes reversely arranged in the compartments of the one group of troughs relatively to those of the other group, of one or more filters M, with connections adapted to receive the electrolyzed juice from the compartments of the one group of troughs containing the positive electrodes and to deliver it into the compartments of the other group of troughs containing the negative electrodes, substantially as specified.

8. In apparatus for the defecation of sugar, as described, the combination of the independent groups of vertically-divided troughs C C', with their positive and negative electrodes reversely arranged in the compartments of the one group of troughs relatively to those of the other groups, the saccharine juice or solution receptacles A A', the water-tanks D D', the fluid-leveling attachments B B', connected with said tanks and receptacles, the pipes $k k' k^2 k^3$, connecting said leveling attachments with the troughs, the receiver J from the group C of troughs, a means or device for transferring the juice from said receiver, the receiving-tank L, connected with said means, the filters M, connected with the tank L, a means or device connected with pipe with the filters for transferring and elevating the filtered juices, the receiving-tank A', connected with said means, the receiver Q for the finished product, and the pipe P, connecting said receiver with the group C' of troughs, essentially as described.

ELIAS MAIGROT.
JOSÉ SABATES.

Witnesses:

JOSEPH A. SPRINGER,
ADOLFO SANCHEZ DOLZ.