

May 12, 1942.

W. J. HOULIHAN

2,282,314

SPINNING TOP

Filed Nov. 20, 1940

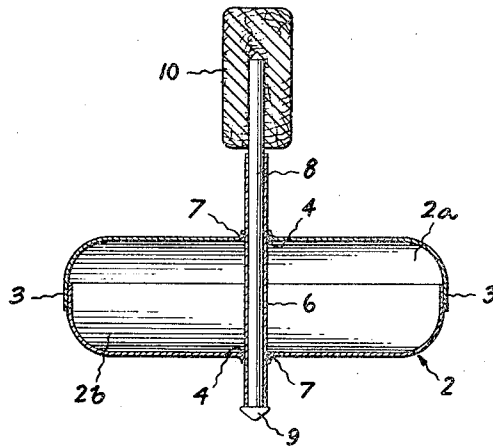

Fig. 1.

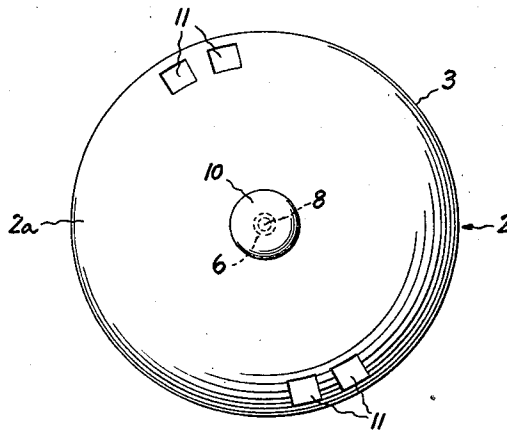

Fig. 2.

Inventor
William J. Houlihan
by J. J. J. J.
Atty.

UNITED STATES PATENT OFFICE

2,282,314

SPINNING TOP

William James Houlihan, Windsor, Melbourne,
Victoria, Australia

Application November 20, 1940, Serial No. 366,466
In Australia November 21, 1939

1 Claim. (Cl. 46—64)

The object of this invention is to provide an improved spinning top of simple and inexpensive construction and which may be spun effectively either by hand or with the aid of a cord or the like, the body of the top being adapted to spin about a central spindle which passes freely therethrough.

Referring to the drawing which forms part of this specification:

Figure 1 is a sectional elevation of the invention and Figure 2 is a plan thereof.

The invention comprises a body member 2, which is preferably of hollow circular form and may be cheaply and conveniently constructed from two sheet metal discs 2a, 2b which are of dished formation as shown in Figure 1.

The marginal portions of the discs form two vertically disposed flanges 3 which fit one within the other and may be pressed together by means of a suitable machine to thereby form a hollow circular body.

Formed centrally through the discs 2a, 2b are holes 4 to receive a vertical tube or sleeve 6, which passes through the body member, and constitutes the hub thereof. The edges of the holes 4 may be turned slightly outwards as indicated at 7, these outturned portions being firmly secured to the sleeve 6.

The sleeve 6 extends for a suitable distance above and below the body member and passing freely through the sleeve is a central spindle 8. This spindle may conveniently consist of a nail or the like, the head of which is of conical form and provides an enlargement 9 on the lower end of the spindle which prevents the latter from being withdrawn through the sleeve 6. It will be evident that the handle 10 on the upper end of the spindle also fulfills a similar function.

The conical enlargement 9 on the lower end of the spindle also provides a suitable point or apex to engage the floor or like surface upon which the top is to spin.

The upper end of the spindle is secured within the handle 10 which may be of wood or other suitable material, the other parts being preferably of metal. In use the top may be spun first by holding the handle in one hand and spinning the body 2 around the spindle 8 with the other hand, the top being then stood up-

right with the lower end of the spindle resting upon the table, floor or like surface. The top will then continue to spin whilst the body 2 maintains sufficient velocity.

Alternatively, the top may be spun by holding one end of a cord against the handle 10 by one hand and coiling the cord around the adjacent upper part of the sleeve 6. The end of the cord on the handle should then be released and by pulling upon the other end of the cord, the body 2 and the sleeve 6 may be rotated at high speed around the spindle, the lower end of which is then placed upon the floor or other surface.

Rectangular openings 11 may be formed in the hollow body 2 for the purpose of causing an audible whistling effect while the top is spinning.

Having now described my invention what I claim as new and desire to secure by Letters Patent is:

A spinning top, comprising a hollow body comprising two members of identical dished form with their marginal edges interfitting and secured together, the upper and lower surfaces of the body being parallel and substantially of the full diameter of the body, the upper and lower surfaces of the body being each formed with an opening, the openings being aligned with the vertical axis of the body with their margins bent outwardly and extended beyond the respective outer surfaces of the hollow body to provide retaining and steadying walls integral with the body, a tubular section passing through said openings and projecting above and below the body, the tubular section snugly fitting within and fixed and materially steadied against lateral play or slipping by the outturned walls of the openings, a spindle snugly though rotatably fitting in said tubular section and extending above and below the same, the lower end of the spindle having a conical terminal bearing against which the lower end of the tubular section seats the terminal providing a spinning point for the top, and a handle secured to the upper end of the spindle the handle bearing on the upper end of the tubular section, the spindle being retained in position in the tubular section by the handle and the conical terminal bearing.

WILLIAM JAMES HOULIHAN.