

March 10, 1936.

L. H. KIENE

2,033,140

INTERNAL COMBUSTION MOTOR VALVE TIMING DEVICE

Filed March 5, 1935

2 Sheets-Sheet 1

Fig. 1.

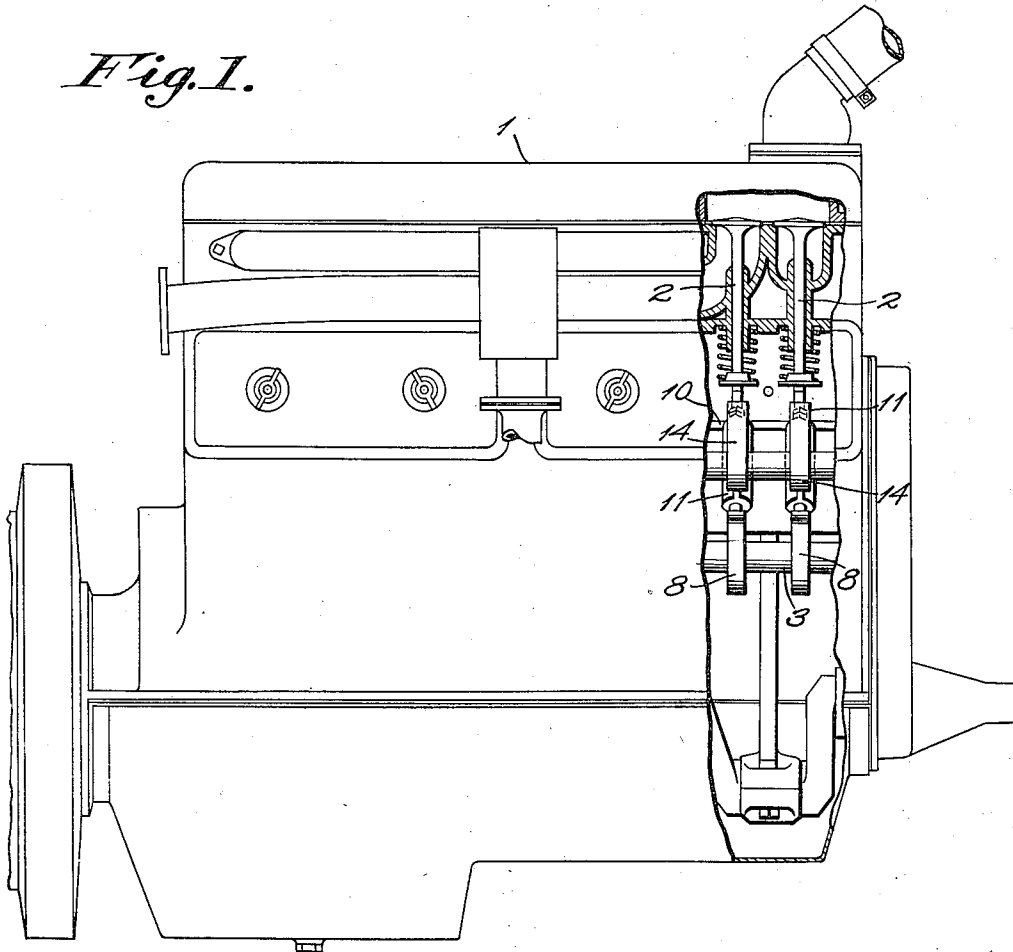

Fig. 2.

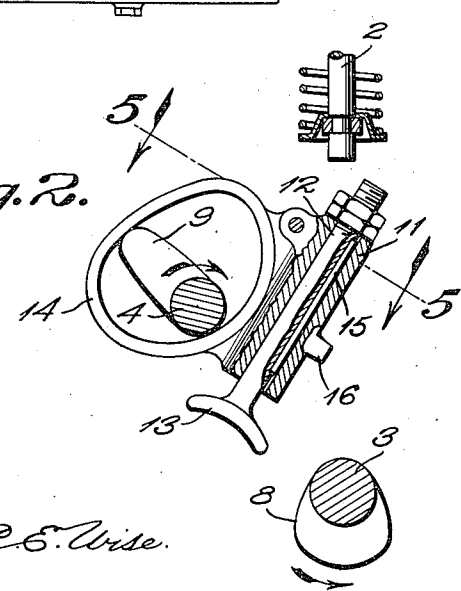
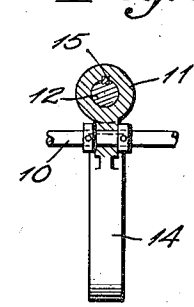

Fig. 5.



Louis H. Kiene

INVENTOR

BY *Victor J. Evans & Co.*

ATTORNEY

WITNESS:

March 10, 1936.

L. H. KIENE

2,033,140

INTERNAL COMBUSTION MOTOR VALVE TIMING DEVICE

Filed March 5, 1935

2 Sheets-Sheet 2

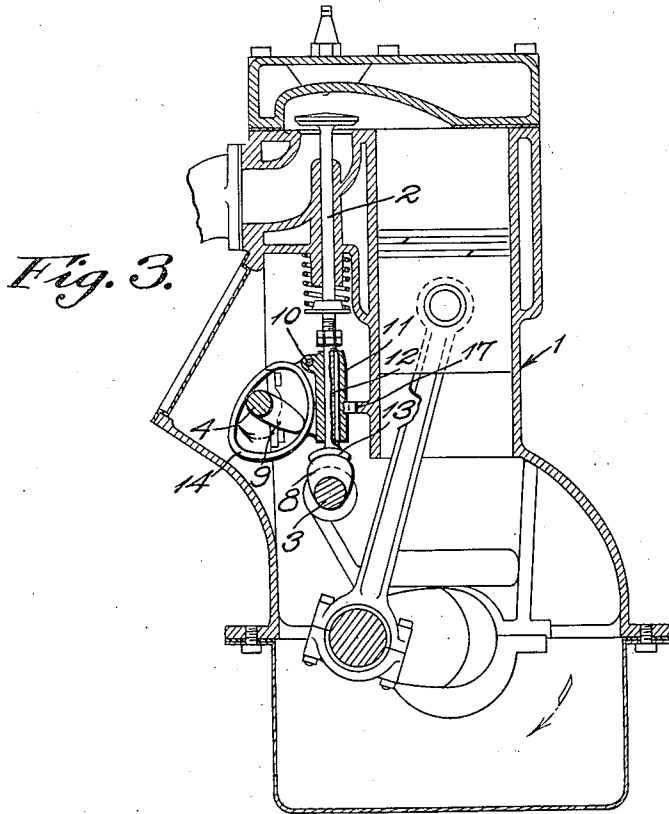

Fig. 6.

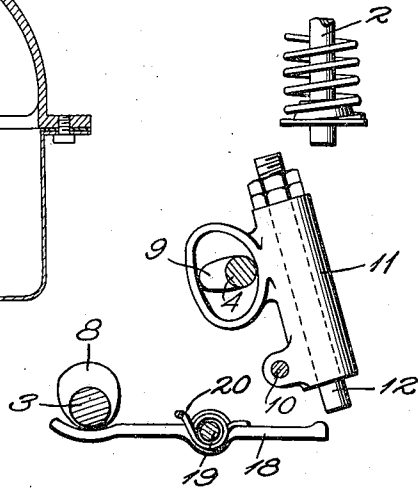
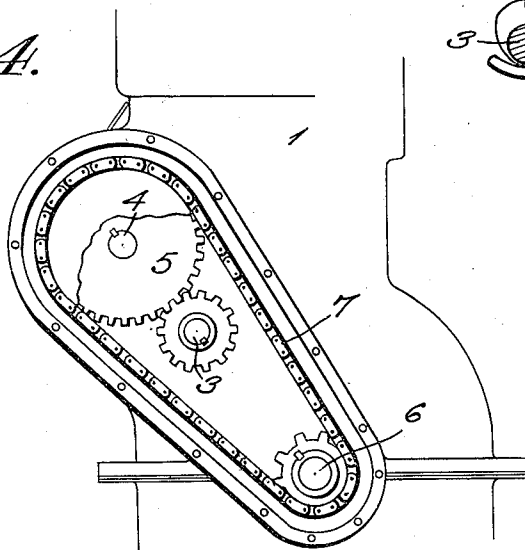

Fig. 4.



R. E. Wise.

WITNESS:

Louis H. Kiene

INVENTOR

BY *Victor J. Evans & Co.*

ATTORNEY

UNITED STATES PATENT OFFICE

2,033,140

INTERNAL COMBUSTION MOTOR VALVE TIMING DEVICE

Louis H. Kiene, Buffalo, N. Y.

Application March 5, 1935, Serial No. 9,492

5 Claims. (Cl. 123-90)

This invention relates to valve timing mechanisms for internal combustion engines, and has for the primary object the provision of a device of this character which will provide more accurate timing of the valves of an engine to render the latter more economical and efficient in operation and is accomplished by opening the valves quicker due to cams rotating at crank shaft speed and having means for preventing the operation of said valves during every other revolution of said cams.

With these and other objects in view, this invention consists in certain novel features of construction, combination and arrangement of parts to be hereinafter more fully described and claimed.

For a complete understanding of my invention, reference is to be had to the following description and accompanying drawings, in which

Figure 1 is a side elevation, partly broken away, illustrating an engine and showing valve operating means constructed in accordance with my invention.

Figure 2 is a fragmentary sectional view showing my invention positioned to interrupt the operation of the valve by the cam.

Figure 3 is a transverse sectional view showing a valve of the engine opened by my invention.

Figure 4 is a fragmentary end view showing the drive between the crank shaft and cam shafts, the cover plate therefor being removed.

Figure 5 is a sectional view taken on the line 5-5 of Figure 2.

Figure 6 is a view similar to Figure 2, showing a modified form of my invention.

Referring in detail to the drawings, the numeral 1 indicates a conventional type of internal combustion engine equipped with spring seated valves 2 for controlling the intake and exhaust ports of the engine. The engine has the usual cam shaft 3 and an auxiliary cam shaft 4. The shafts are connected by gears 5 and one of said gears is connected to the crank shaft 6 by a sprocket chain 7. The drive between the crank shaft and said cam shafts is such that the cam shaft 3 rotates at the same rate of speed as the crank shaft while the cam shaft 4 rotates at one-half speed of the crank shaft. The cam shafts 3 and 4 are equipped with cams 8 and 9. The cam shaft 3 is arranged in alignment with the valves while the cam shaft 4 is disposed laterally of said valves and in a plane above the cam shaft 3.

A horizontally arranged supporting shaft 10 is carried by the engine 1 laterally of said valves and in a plane below the lower ends of the valves and

has journaled thereon valve lifter guides 11 and which slidably support valve lifters 12, the lower ends of which are provided with heads 13 having arcuately curved cam engaging faces to be engaged by the cams 8 and the latter each are of substantially fan shape while the cams 9 are of elongated formation.

Cam races 14 are fixed to the valve lifter guides and receive therein the cams 9 which during their rotation move or swing the lifter guides on the supporting shaft 10 to position the lifters in alignment and out of alignment with the valves and cams 8 as suggested in Figures 3 and 2.

Internal ribs 15 are provided on the valve lifters or the stems thereof and operate in grooves in the lifter guides to prevent rotation of the lifters within the guides but still permitting the lifters to slide relative thereto. Stops 16 and 17 are provided on the lifter guides and the engine 1 to abut one another for the purpose of limiting the swinging movement of the lifter guides in one direction so as to bring about proper aligning of the lifters with the valves and cams 8 during a certain position of the lifter guides.

The cams 8 and 9 are so arranged for the timing of the valves that the cams 9 will position the lifters in alignment with the valves and cams 8 to bring about quick opening of the valves during one rotation of the cams 8 and during the next rotation of said cams 8, the cams 9 move the lifter guides and the lifters out of alignment with the valves and cams 8 so that the valves during the last referred to rotation of the cams 8 will be unaffected by said cams 8 or, in other words, permitted to remain closed. The cams 8 rotating at crank shaft speed bring about quick opening of the valves which assures more efficient operation of the engine by permitting a better intake of fuel to the engine and exhaust of the spent gases from the engine.

Referring to my modified form of invention, as shown in Figure 6, rocker arms 18 are provided as operating mediums between the cams 8 and the valve lifters 12. The cams 8 in this form of invention are located laterally of the valves and the rocker arms are journaled on a supporting shaft 19 and equipped with springs 20 acting to bring the rocker arms in continuous engagement with the cams 8. Also in this form of invention the valve lifters have the heads 13 omitted.

Having described the invention, I claim:

1. In an internal combustion engine having spring seated intake and exhaust valves and a crank shaft, main and auxiliary cam shafts jour-

naled to the engine, driving means between the crank shaft and the cam shaft whereby the main cam shaft will rotate at crank shaft speed and the auxiliary crank shaft will rotate at one-half crank shaft speed, cams on said cam shafts, lifter guides pivotally mounted to the engine, lifters slidably supported by said guides for imparting movement to the valves by the cams of the main cam shaft, and means between the lifter guides and the cams of the auxiliary cam shaft to position the lifters and guides out of the path of movement of the cams of the main cam shaft.

2. In an internal combustion engine having spring seated intake and exhaust valves and a crank shaft, main and auxiliary cam shafts journaled to the engine, driving means between the crank shaft and the cam shaft whereby the main cam shaft will rotate at crank shaft speed and the auxiliary crank shaft will rotate at one-half crank shaft speed, cams on said cam shafts, lifter guides pivotally mounted to the engine, lifters slidably supported by said guides for imparting movement to the valves by the cams of the main cam shaft, and cam races fixed to the lifter guides and engaged by the cams of the auxiliary shaft.

3. In an internal combustion engine having spring seated intake and exhaust valves and a crank shaft, main and auxiliary cam shafts journaled to the engine, driving means between the crank shaft and the cam shaft whereby the main cam shaft will rotate at crank shaft speed and the auxiliary crank shaft will rotate at one-half crank shaft speed, cams on said cam shafts, lifter guides pivotally mounted to the engine, lifters slidably supported by said guides for imparting movement to the valves by the cams of the main cam shaft, cam races fixed to the lifter guides and engaged by the cams of the auxiliary shaft, said cams of the main cam shaft being of substantially fan shape and the valve lifters hav-

ing heads provided with arcuately curved faces to be engaged by the cams of the main cam shaft.

4. In an internal combustion engine having intake and exhaust valves and a crank shaft, main and auxiliary cam shafts journaled to the engine, lifter guides pivoted to the engine, cams on said cam shafts, cam races fixed to the lifter guides and engaged by the cams of the auxiliary cam shaft, valve lifters slidable in said guides, rocker arms journaled to the engine and engaging the cams of the main cam shaft and adapted to actuate the valve lifters during one revolution of the crank shaft, said valve lifters being positioned by the cams of the auxiliary cam shaft out of the path of movement of the rocker arms during the next revolution of the crank shaft, and a drive means between the cam shafts and the crank shafts whereby the main cam shaft will be rotated at crank shaft speed and the auxiliary crank shaft rotated at one-half crank shaft speed.

5. In an internal combustion engine having spring seated intake and exhaust valves and a crank shaft, main and auxiliary cam shafts journaled to the engine, driving means between the crank shaft and the cam shafts whereby the main cam shaft will rotate at crank shaft speed and the auxiliary cam shaft will rotate at one-half crank shaft speed, cams on said cam shafts, valve lifter means engageable with the valves and the cams of the main cam shaft for opening and closing the valves during a revolution of the crank shaft, and means connecting said valve lifter means to the cams of the auxiliary cam shaft to move the valve lifter means out of engagement with the cams of the main cam shaft during the next revolution of the crank shaft to permit said valves to remain closed.

LOUIS H. KIENE.