

(12) PATENT
(19) AUSTRALIAN PATENT OFFICE

(11) Application No. AU 199676342 B2
(10) Patent No. 720422

(54) Title
Electrical socket device

(51)⁷ International Patent Classification(s)
H01R 013/66

(21) Application No: **199676342**

(22) Application Date: **1996.11.22**

(87) WIPO No: **WO97/20367**

(30) Priority Data

(31) Number	(32) Date	(33) Country
9524114	1995.11.24	GB

(43) Publication Date : **1997.06.19**

(43) Publication Journal Date : **1997.08.14**

(44) Accepted Journal Date : **2000.06.01**

(71) Applicant(s)
Sapphire Networks Limited

(72) Inventor(s)
Malcolm John Burlinson; David Maurice Burlinson; Ian Clarke

(74) Agent/Attorney
FISHER ADAMS KELLY,GPO Box 1413,BRISBANE QLD 4001

(56) Related Art
GB 2282273
WO 95/31840



INTEI

(51) International Patent Classification ⁶ :
H01R 13/66

A1

(11) International Publication Number: **WO 97/20367**

(43) International Publication Date: 5 June 1997 (05.06.97)

(21) International Application Number: PCT/GB96/02891

(22) International Filing Date: 22 November 1996 (22.11.96)

(30) Priority Data:
9524114.7 24 November 1995 (24.11.95) GB

(71) Applicant (for all designated States except US): SAPPHIRE NETWORKS LIMITED [GB/GB]; Sapphire House, Market Street, Fordham, Ely, Cambridgeshire CB7 5LQ (GB).

(72) Inventors; and

(75) Inventors/Applicants (for US only): BURLINSON, Malcolm, John [GB/GB]; 30 Pages Lane, Higham, Bury Saint Edmunds, Suffolk IP28 6NJ (GB). BURLINSON, David, Maurice [GB/GB]; 12 Bury Road, Mildenhall, Suffolk IP28 7HT (GB). CLARKE, Ian [GB/GB]; Trehill, Okehampton, Devon EX20 2RZ (GB).

(74) Agent: MAGUIRE & CO.; 5 Crown Street, St. Ives, Cambridgeshire PE17 4EB (GB).

(81) Designated States: AL, AM, AT, AU, AZ, BB, BG, BR, BY, CA, CH, CN, CU, CZ, DE, DK, EE, ES, FI, GB, GE, HU, IL, IS, JP, KE, KG, KP, KR, KZ, LC, LK, LR, LS, LT, LU, LV, MD, MG, MK, MN, MW, MX, NO, NZ, PL, PT, RO, RU, SD, SE, SG, SI, SK, TJ, TM, TR, TT, UA, UG, US, UZ, VN, ARIPO patent (KE, LS, MW, SD, SZ, UG), Eurasian patent (AM, AZ, BY, KG, KZ, MD, RU, TJ, TM), European patent (AT, BE, CH, DE, DK, ES, FI, FR, GB, GR, IE, IT, LU, MC, NL, PT, SE), OAPI patent (BF, BJ, CF, CG, CI, CM, GA, GN, ML, MR, NE, SN, TD, TG).

Published

With international search report.

Before the expiration of the time limit for amending the claims and to be republished in the event of the receipt of amendments.

(54) Title: ELECTRICAL SOCKET DEVICE

(57) Abstract

An electrical outlet device comprising a member defining a socket aperture, means defining a socket aligned with the socket aperture and having an array of electrical contacts therein and means by which the outlet device is secured in position in use, characterised by a body member having a plurality of electrical connections for conductors in a cable, and by means forming electrical connections between the cable connections and the array of electrical contacts in the socket, and in that the body member is releasably connected to the said socket aperture defining member.

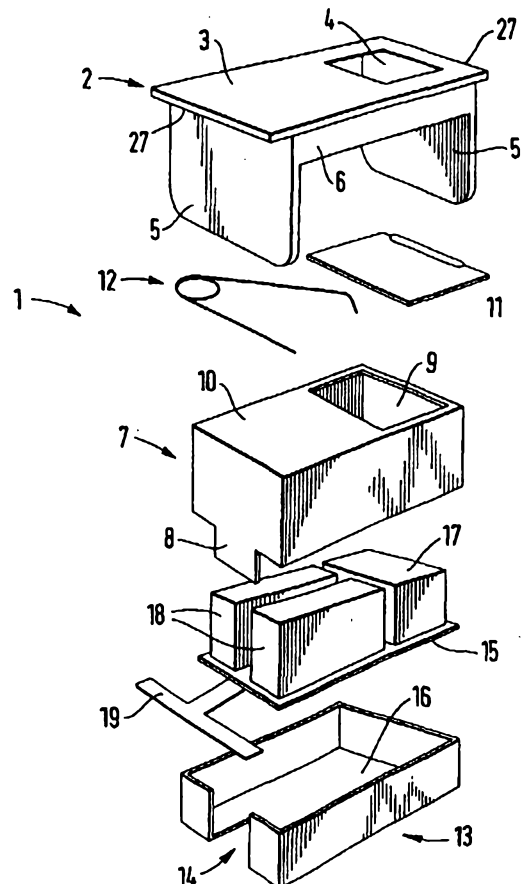

mounted on to the front of a wall plate. The face plate conventionally carries a member defining a jack plug socket, a member carrying an array of cable terminals, i.e. IDC terminals, and a printed circuit board connecting an array of contacts in the socket with the IDC terminals. In such an arrangement, the socket forming member will normally have to face in a direction opposite to that of the IDC terminals. Thus the socket will be arranged to open through the face plate while the IDC terminals will be arranged to project from the rear of the face plate so that they are accessible for connection to a network cable by an installation engineer.

It is an object of the invention to provide a network outlet device which is relatively easy to manufacture or assemble in that the main electrical components, i.e. the terminals (e.g. IDC terminals) and the socket member can be assembled on a single printed circuit board, and preferably all on the same side of the board.

It is a particular object of the invention to provide an outlet device in which the terminals are separable from the part of the device by which it is fixed in position during use, e.g. the face plate, to facilitate installation.

It is another object of the invention to provide a network outlet port which facilitates installation.

It is a further object of the invention to provide an electrically shielded network outlet port.

It is a yet further object of the invention to provide

a network wall outlet made from relatively simple components.

It is a still further object of the invention to provide a wall outlet which lends itself to a situation 5 where limited space, and particularly limited depth, is available.

DISCLOSURE OF INVENTION

The present invention is an electrical outlet device comprising a member defining a socket aperture, means 10 defining a socket aligned with the socket aperture and having an array of electrical contacts therein and means by which the outlet device is secured in position in use, characterised by a body member having a plurality of electrical connections for conductors in a cable, and by 15 means forming electrical connections between the cable connections and the array of electrical contacts in the socket, and in that the body member is releasably connected to the said socket aperture defining member.

The said socket aperture defining member may carry the 20 means by which the outlet device is secured in position in use. The means defining the socket may be mounted on the body member. The body member may be a push fit on the socket defining member. Snap-action connections may be provided to releasably connect the body member and the 25 socket aperture defining member. The snap-action connectors may be arranged for engaging opposed ends of the respective said members.

The said socket aperture defining member may be a face

plate adapted for reception in or on a wall plate to secure the outlet device in position in use. The face plate may comprise a front face member, a pair of flanges extending rearwardly from positions adjacent to opposed ends of the rear of the front face member, means limiting the depth of insertion of the face plate into an aperture in the wall plate and the pair of flanges being adapted for releasably receiving the body member.

The body member may be a cover formed as an open-topped box-like structure. The cover may be secured to the said socket aperture defining member by means of a back box adapted to mate snugly with the cover to form a closed box-like structure enclosing electrical components of the outlet device. The back box may be an open-topped box-like structure. The closed box-like structure may comprise metal plated plastics mouldings forming an electrical shield enclosing the outlet device.

The outlet device may comprise a shutter for closing the aperture in the member, the shutter being slidably mounted between the member and back box, and being resiliently urged to close the aperture.

The electrical outlet device may comprise a printed circuit board carried by the cover and which forms the conductor means for connecting the cable connections to the contact array in the socket defining member. The socket defining member may be mounted on the printed circuit board. The printed circuit board may carry a cable retaining strap adapted to be secured to the cable. The

cable retaining strap may be electrically connected to an earthed portion of the printed circuit board. The cable retaining strap may be electrically connected to the shielding provided by the metal plating on the closed box-like structure. The cable restraining strap may be adapted for connection to the shielding around the electric cable.

The outlet device may comprise snap-action connections securing the cover and the back box together.

It will be understood that the socket device of the present invention enables an installation engineer to fit a computer network cable to the cover while it is separated from the face plate, thus facilitating the installation process, whereas with a conventional socket device, the tail of the network cable must be passed through the aperture in the wall plate which is to receive the face plate, before the cable can be connected to the socket device. Thus with the device of the present invention, the cable tails can be shorter.

BRIEF DESCRIPTION OF DRAWINGS

The invention is diagrammatically illustrated, by way of example, in the accompanying drawings in which:-

Figure 1 is an exploded perspective view of a modular computer network outlet;

Figure 2 is an exploded perspective view of the outlet of Figure 1 with the various components of the outlet partly assembled to form two sub-assemblies, and

Figure 3 is a view generally similar to that of Figure 1 of a modified version of the outlet for use where a face

plate is not required.

BEST MODES FOR CARRYING OUT THE INVENTION

In the drawings there is shown an electrical socket device (1) intended as a modular computer network outlet and comprising a generally rectangular face plate (2) having a front face member (3) formed with a generally square aperture (4) through which a plug or jack (not shown) can be inserted to make electrical contact with the outlet. The face plate (2) comprises a pair of flanges (5) extending rearwardly from its front face member (3) adjacent to opposite ends (27) thereof and which are formed with snap-action catches (20) (see Figures 2) by which the face plate may be engaged in an aperture in a wall plate (not shown). Such a manner of engagement is known as such and involves inserting the face plate into the wall plate from the front of the wall plate until the ends (27) engage the wall plate whereupon the catches (20) engage the rear of the wall plate to fix the face plate in position. Relatively narrow webs (6) (only one of which is visible in the drawings) extend between the flanges (5) along opposite sides of the face plate to form a shallow tray on the rear surface of the face plate for receiving and locating a back box (7).

The back box (7) is an open-topped box-like structure having a locating lug (8) projecting from one end for the purpose appearing below and which is formed with an aperture (9) in its bottom face which aligns with the corresponding aperture (4) in the face plate (2). The back

box (7) is adapted to be received snugly in the tray in the rear face of the face plate (2) and to engage with the face plate by means of snap action connections (21) (see Figure 2) whereby the face plate and the back box form a unitary assembly which trap between them a sliding shutter (11) which is urged to close the aperture (4) in the face plate by means of a spring (12) located between the face plate and the back box.

The open side of the back box (which faces downward in Figure 1 and rearwardly in Figure 2) is closed by means of a cover (13) which is an open-topped box-like structure adapted to mate snugly with the back box (7) and to be held on the back box by means of snap-action connectors (22) or the like on the cover and which engage in corresponding apertures (23) in the lugs (5). The cover (13) is formed with a cut-out or aperture (14) in one end through which an electrical network cable (not shown) may enter the box-like enclosure comprising the cover and the back box. The locating lug (8) is arranged to be received in the cut-out (14) to prevent mis-assembly. The back box (13) carries a printed circuit board (15) which is held in the base (16) of the back box by means of snap-action connectors (24) and the printed circuit board carries a member (17) defining a socket (25) for receiving the said plug or jack and a plurality of electrical connectors (18), for example IDC connectors, by which the individual conductors of the network cable are electrically connected to the device. Electrical connection between an array of contacts (not

shown) in the jack socket (25) and the connectors (18) are provided by the printed circuit board (15) which also carries a metal strain relief and earthing strap-and-buckle device (19) which is intended to be wrapped around the network cable (not shown) and crimped thereto to provide a good mechanical connection of the cable to the electrical socket device and to earth the device to a printed circuit board and also to earth the device to a cable shield, if provided. Preferably the back box and the cover will be plated with metal which is electrically connected to the printed circuit board and thus to the network cable to shield the socket in use.

The outlet device of Figure 3 is generally similar to that described above with reference to Figures 1 and 2 except that the face plate is not required and thus not present. Instead the outlet device is secured in position in use by connecting the back box directly to a suitable surface or aperture at the required site. The connection may be in any suitable manner e.g. by snap-action connectors (not shown) or the like.

As shown the jack plug outlet socket (25) emerges from the back box through an aperture (9) in an end face, although in this embodiment it could be arranged to emerge through any convenient face of the back box or cover.

It will be appreciated that normally the various components of the outlet will be plastics injection mouldings. The snap-action connections for holding the components of the outlet together may be replaced by other

connections, e.g. welded connections or by means of an adhesive or any other suitable means.

INDUSTRIAL APPLICABILITY

The outlet in accordance with the invention
5 facilitates installation in that the assembly comprising
the cover carrying the printed circuit board which in turn
carries the jack socket and the electrical connectors can
be wired to an electrical cable before the cover is mounted
on the back box or back box-and-face plate assembly. Thus
10 the installation engineer can wire the outlet without
having first to pass the tail of the cable through a wall
plate aperture, as is normally the case.

The invention thus provides an improved electrical
outlet.

CLAIMS

1. A modular computer network wall outlet device comprising a wall plate defining an aperture, a face plate member defining a socket aperture, the face plate member being mounted in the aperture in the wall plate, a body member having a plurality of electrical connectors for conductors in a cable, means defining a socket mounted on the body member, aligned with the socket aperture and having an array of electrical contacts therein, wherein the body member has circuit means forming electrical connections between the cable connections and the array of electrical contacts in the socket, the socket and electrical contacts being on the same face of the circuit means and the body member is releasably connected to the face plate member.
2. A computer network wall outlet device according to claim 1, characterised in that the body member is a push fit on the face plate member.
3. A computer network wall outlet device according to claim 1 or claim 2, characterised by snap-action connectors to releasably connect the body member and the face plate member.
4. A computer network wall outlet device according to claim 3, characterised by oppositely disposed snap-action connectors for engaging opposed ends of the respective said members.
5. A computer network wall outlet device according to any preceding claim, characterised in that the face plate

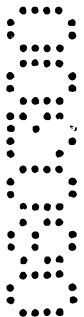

member comprises a front¹¹ face member, a pair of flanges extending rearwardly from positions adjacent to opposed ends of the rear of the front face member, and means limiting the depth of insertion of the face plate 5 into the aperture in the wall plate and in that the pair of flanges are adapted for releasably receiving the body member.

6. A computer network wall outlet device according to any preceding claim, characterised in that the body member 10 comprises a cover formed as an open-topped box-like structure.

7. A computer network wall outlet device according to claim 6, characterised in that the cover is secured to the face plate member by means of a back box adapted to mate 15 snugly with the cover to form a closed box-like structure enclosing electrical components of the outlet device.

8. A computer network wall outlet device according to claim 7, characterised in that the back box is an open-topped box-like structure.

20 9. A computer network wall outlet device according to claim 7 or claim 8, characterised in that the closed box-like structure comprises metal plated plastics mouldings forming an electrical shield enclosing the outlet device.

10. A computer network wall outlet device according to 25 any one of claims 7 to 9, characterised by a shutter for closing the aperture in the face plate member, the shutter being slidably mounted between the face plate member and back box, and being resiliently urged to close the

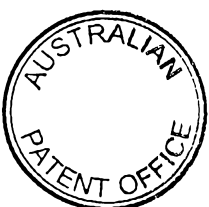

aperture in the face plate¹² member.

11. A computer network wall outlet device according to any one of claims 6 to 10, characterised in that the circuit means is a printed circuit board carried by the
5 cover.

12. A computer network wall outlet device according to claim 11, characterised in that the face plate member is mounted on the printed circuit board.

13. A computer network wall outlet device according to
10 claim 11 or claim 12, characterised in that the printed circuit board carries a cable retaining strap adapted to be secured to the cable.

14. A computer network wall outlet device according to
15 claim 13, characterised in that the cable retaining strap is electrically connected to an earthed portion of the printed circuit board.

15. A computer network wall outlet device according to claim 13 or 14 when dependent on claim 9, characterised in that the cable retaining strap is electrically connected
20 to the shielding provided by the metal plating on the closed box-like structure.

16. A computer network wall outlet device according to any one of claims 13 to 15, characterised in that the cable restraining strap is adapted for connection to the
25 shielding around the electric cable.

17. A computer network wall outlet device according to any one of claims 7 to 16 characterised by snap-action connections securing the cover and the back box together.

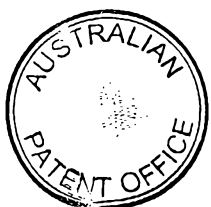

1/3

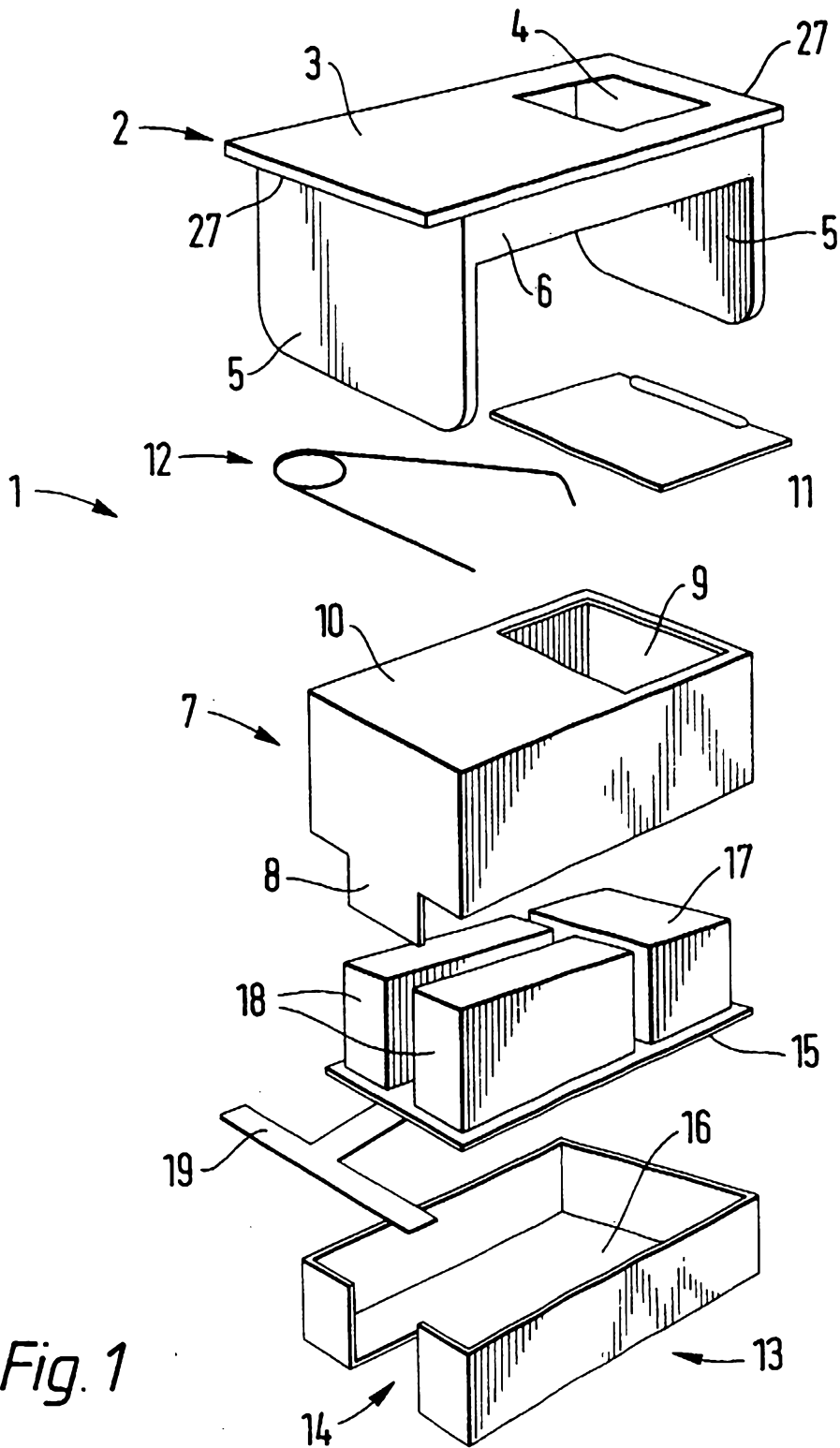

Fig. 1

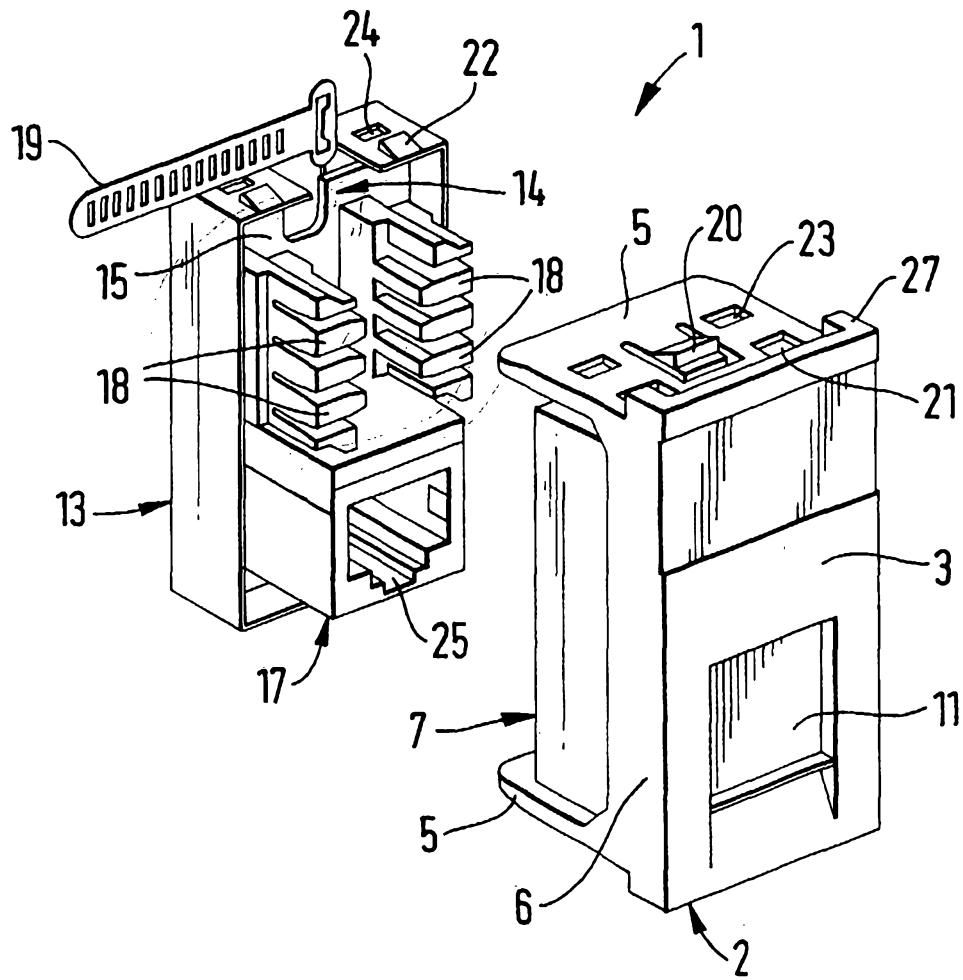

Fig. 2

3/3

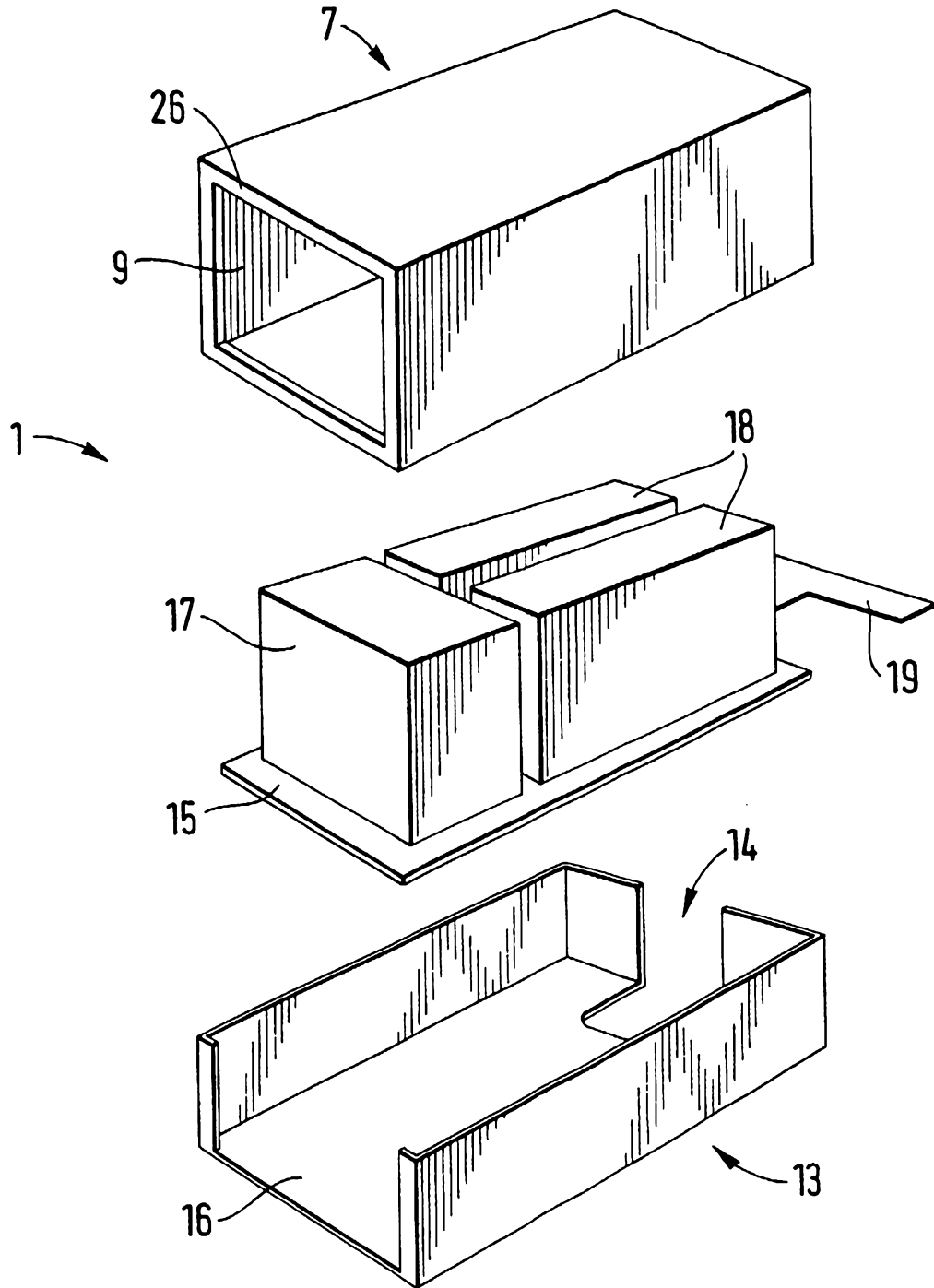

Fig. 3