

(19)  
(12)

(KR)  
(A)

(51) 。 Int. Cl. <sup>7</sup>  
B60B 37/00

(11)  
(43)

2002 - 0021317  
2002 03 20

(21) 10 - 2001 - 0048236  
(22) 2001 08 10

(30) 09/661,479 2000 09 14 (US)

(71) 13270

(72) #40 1651

4507

13 25413

16350

8448

14308

35190

12760

3215

1333

8 3034

(74)

:

(54)

가 가 가

3

1 2 /4 가 ;

2 1 2 - 2 ;

3 2 , / / ;

4a 16b

\*

20 : 22 :

32 : 46 :

54 : 56 :

58 : 60 :

61 : 68 :

2 /4 가 가

2 /4 가 5,740,895

가 가

(suspension), 가 (load) 가 ,  
가 5,740,895 (outboard end)  
(shoulder)  
5,984,422 가 가  
/ 가  
가  
5,984,422 (preload) 가 가  
가  
1 ) .( 4a 4b )  
2 ( ) .( 5) 가  
3 (screw thread) 가  
.( 6)  
4 , (dog lugs) 가  
.( 7)  
5  
.( 8a 8b)

6  
 ( 9)  
 7 (finger) 가  
 .( 10a 10b)  
 8 가 (cavity)  
 ( 11)  
 9 가 ( ) .( 12a,  
 12b 12c)  
 10 .( 13a, 13b ( ) 13c)  
 11 ,  
 14a (retainer) .( 14b) 5,740,895 .(  
 12 ( , ) D (key) .( 15a  
 15b)  
 13 가 .( 16a) (dowel pin) 가  
 .( 16b) /  
 ; 4  
 ;  
 1 (E), (20), (22), (36, 38) ( (32, 34) (28, 30) (24, 26) )  
 (24) (shift mechanism)(40) (E)  
 (32) (36)  
 (24), (28) (32) (36) (32) (36)

2 (36), (42), (44) (46) (48) 가  
 (shock absorber)(50)

3 2 (46) (54)  
 (integral outboard flange)(52) (54)  
 ( ) 가 (48) (46) (36)( 2

(56) (54) (56) (R) (54) (56)  
 가 (R) ( )  
 (32) (56) (32) / (56) CV  
 (33) 가

1 1  
 4a 1 (56) 가  
 (58) (61)  
 (54)

(60) (56) (58) (59)  
 (60) (60) (61) (6)  
 2) (32) (64) 가 (32) (60) (56)  
 (66, 68) (33)

(68) (60) (32) (62, 64) 가 (48)  
 (media source)( ) (70) ( )  
 ) 4b (58) (62, 64) (56) (60) (66,  
 68) (55, 59)

2 2

2 5 (54a) (56a)  
 (72) (68) (74)  
 (61a) (54a) (74) (32a) (68)

3 3

3 6 (54b) (56b) (78)  
 (76) , (80)  
 (80) (56b) (54b) (56b)  
 (82) (68) (82) (32b) (84)  
 2b) / (82) (68) (56b) (3)

4 4

7 4 (56c) ( ) (86) 가  
 (61c) ( )  
 62c) 가 (60c) (88) (54c) 가  
 (61c)

5 5

8a 5 (56d) (61d) (92) (9  
 0) 가 (60d) (92) (94) (90)  
 가 가 (54d) 가  
 8b 가  
 (95)

6 6

9 6 (56e) (97) 가 (96)  
 (60e) (97)  
 96) (98)

7 7

10a 7 (56f) (100)가 (60f)  
 ( 10a ) (102) (102) (104)  
 (54) 가

8 8

11 8 (56g) (106)  
 (108) 가 (60g) (54)  
 (106, 108) (cavity)  
 (110)

9 9

12a 9 (56) (61h) (60h)  
 (54) 가 (61h) ,  
 (60h) (61h) ( ) 12b  
 가 , 12c (112) 12c " 113"  
 (60h'')

10 10

13a, 13b 13c 12b 12c (60i, 60i', 60i'') (56) (61i, 61i', 61i'')  
 (119) (60i)가 13a " 117" (54) /  
 (116)

11 11

14a 11 (60j) (56j) (6  
 1j) (118) (120) 가 .  
 (122) (120) (60j) 5,  
 772,373 5,618,143

14b 14a (36j')

12 12

15a 15b 12 (60k) (56k) (61k)  
 (54) (60k) (60k) (3  
 2) / (56k) (68)  
 (56k) , 15b ,  
 (124, 126) 가 , , D

13 13

16a 16b 13 (61m) 가  
 (54) 가  
 (61m) (60m) (128)  
 (128) 가 16b  
 (132, 134) (130)

가

/

4

가

(57)

1.

;

가

;

;

;

;

,

가

,

4 /2

,

가

.

2.

1

,

,

4 /2

가

.

3.

;

가

;



;

가

,

가

,

,

4 /2

가

4.

;

가

;

;

;

;

,

,

4 /2

가

.

5.

;

가

;

;

;

,

, 가 4 /2 가 ,

6.

;

가

;

;

;

;

;

/

,

,

4 /2

가

7.

6

,

4 /2

가

.

8.

;

가

;

;

;

,

4 /2

가

,

.

9.

;

가

;

;

;

;

,

가

.

4 /2

10.

;

가

;

;

;

;

,

,

4 /2

가

.

11.

;

가  
;

;

;

;

,

가  
4 /2 가

12.

11 ,

4 /2 가

13.

11 ,

가

,

4 /2 가

14.

;

가  
;

;

가 ;

;

;

;

,

가

4 /2

가

15.

;

가

;

가

;

;

;

가

4

/2

가

16.

15

,

4 /2

가

17.

;

가

;

;

;

4 /2

가

18.

;

가

;

가

;

;

;

,

가

,

가

,

4 /2

가

.

19.

가

;

;

;

;

;

가

가

;

가

;

가

,

,

4 /2

가

.

20.

19

,

4 /2

가

1

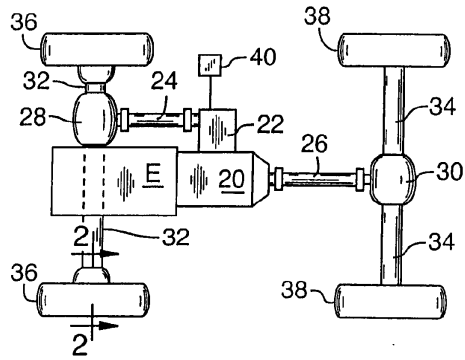

2

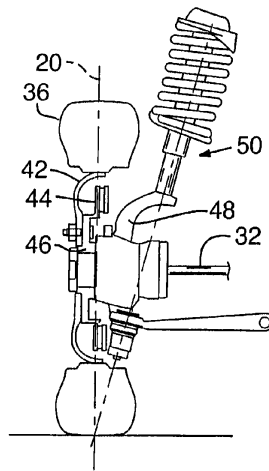

3

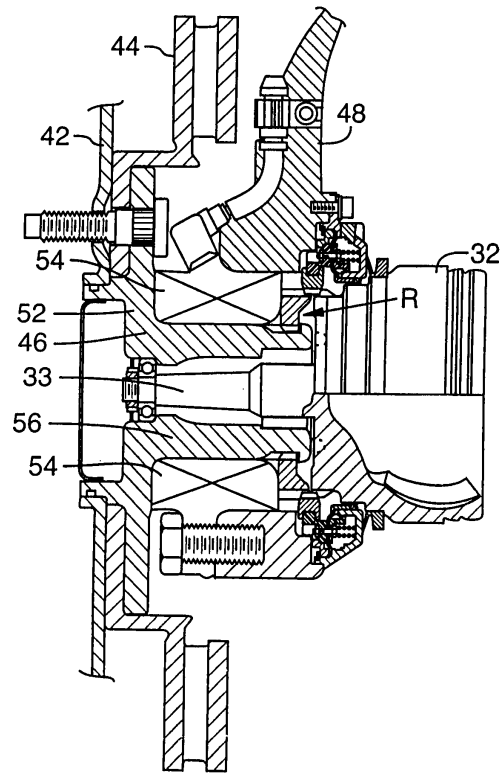



4a

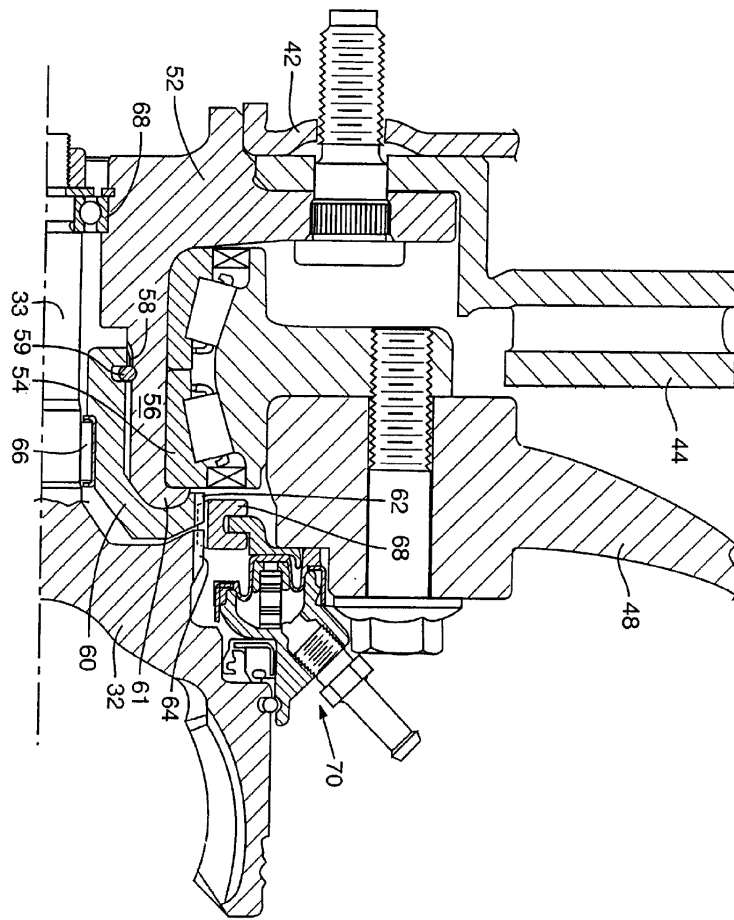

4b

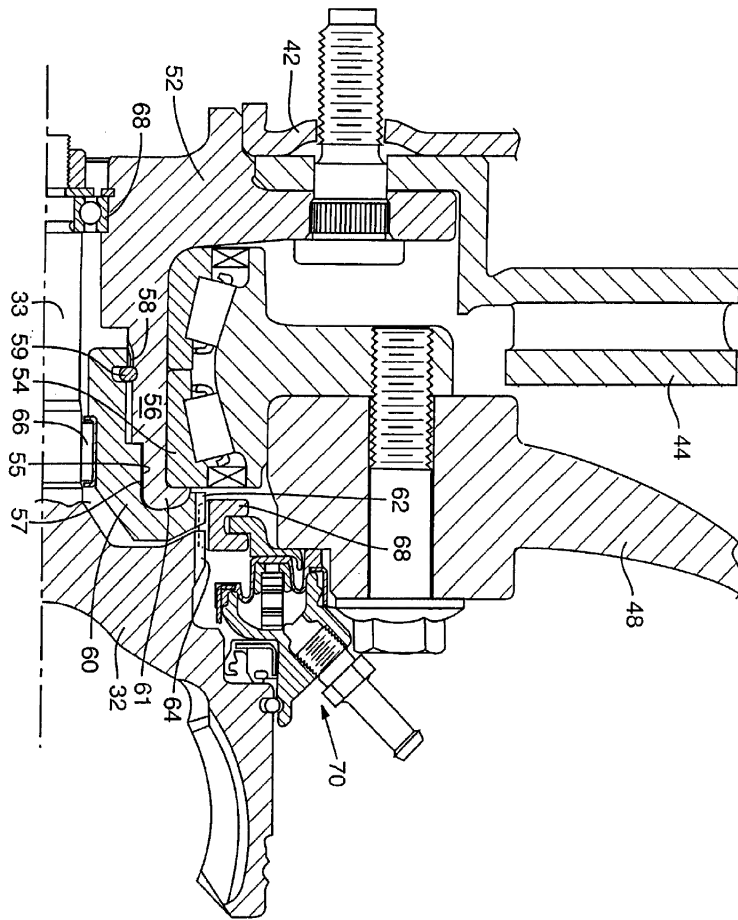

5

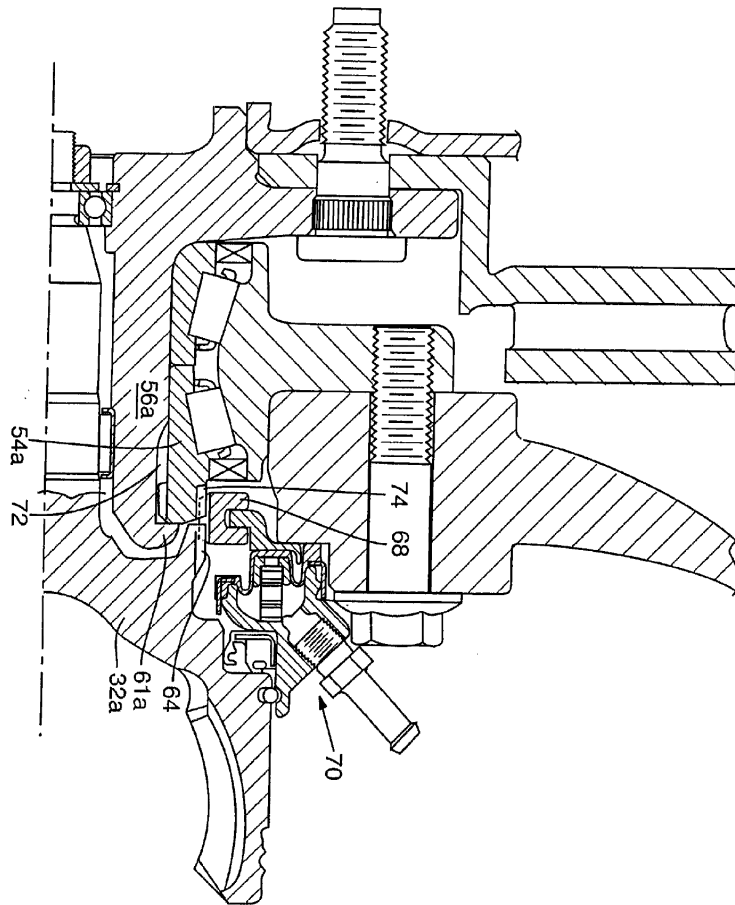

6

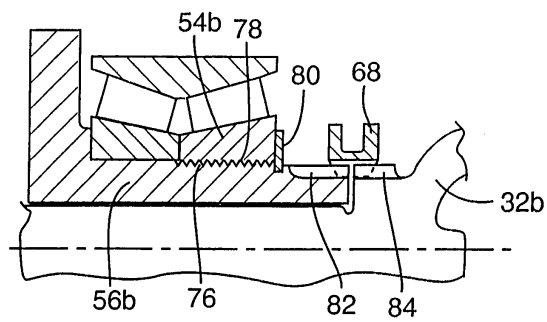

7

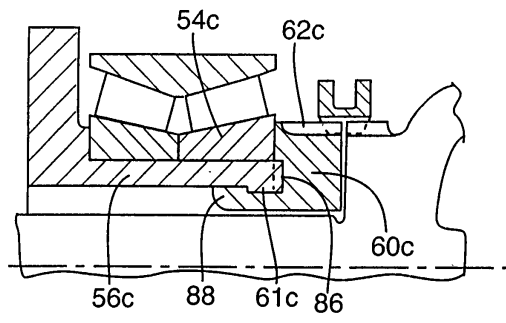

8a

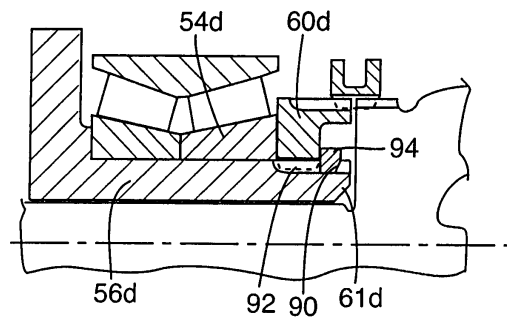

8b

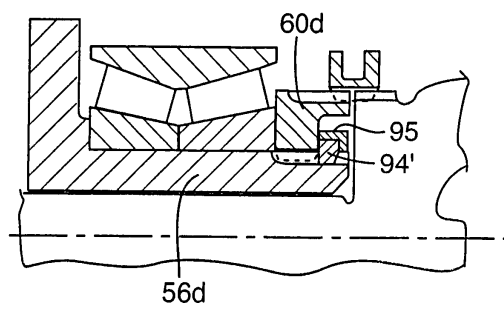

9

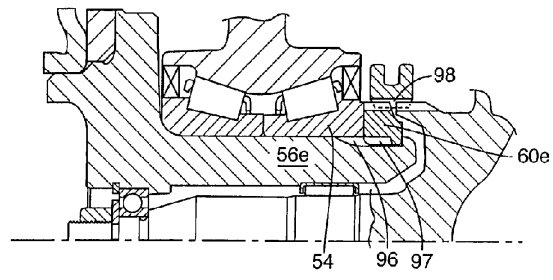

10a

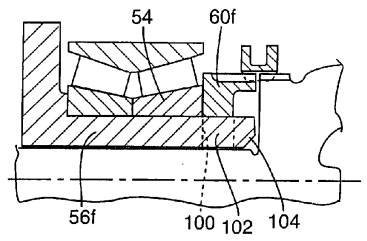

10b

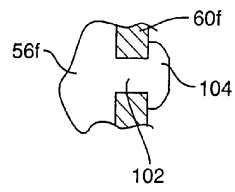

11

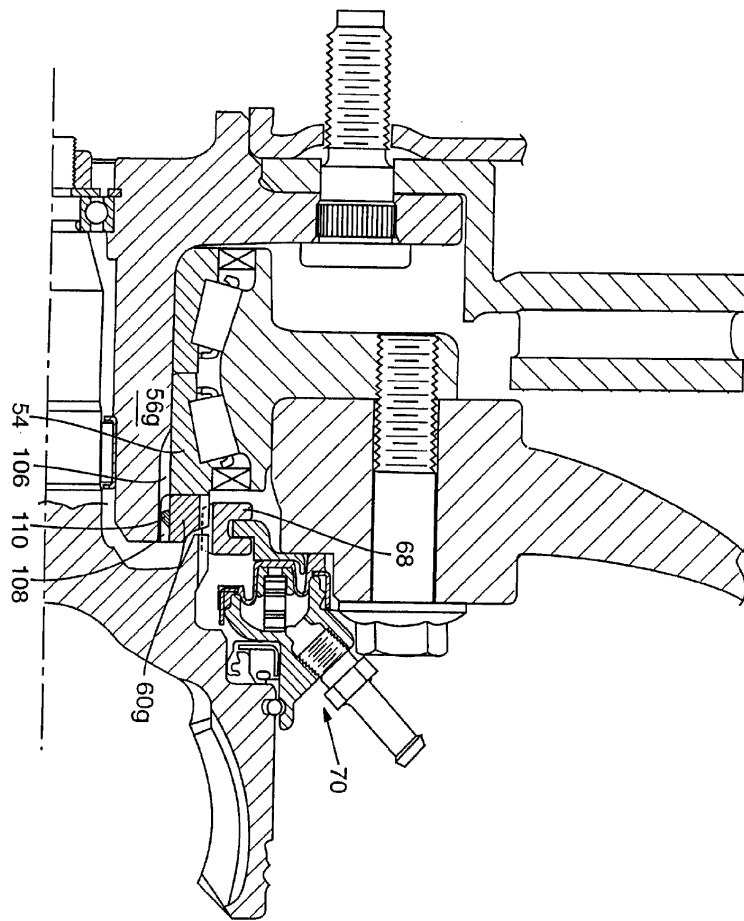

12a

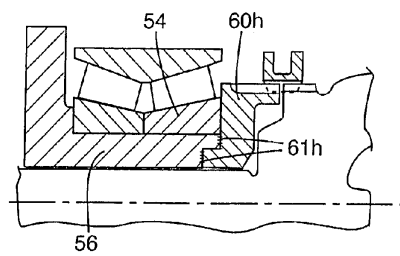

12b

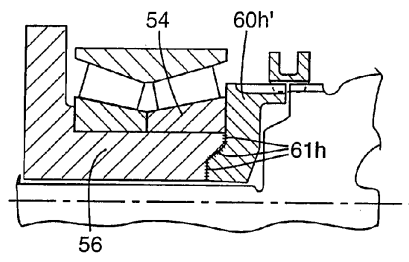

12c

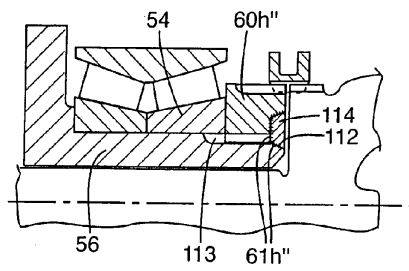

13a

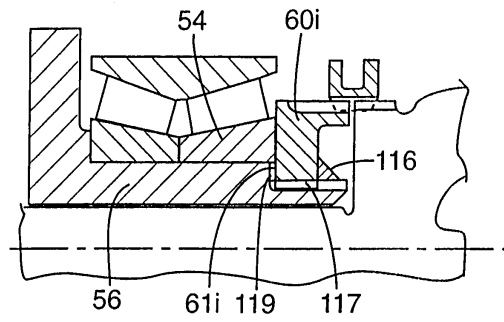

13b

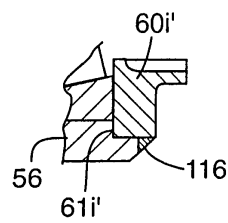

13c

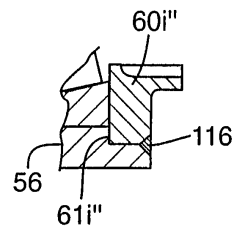

14

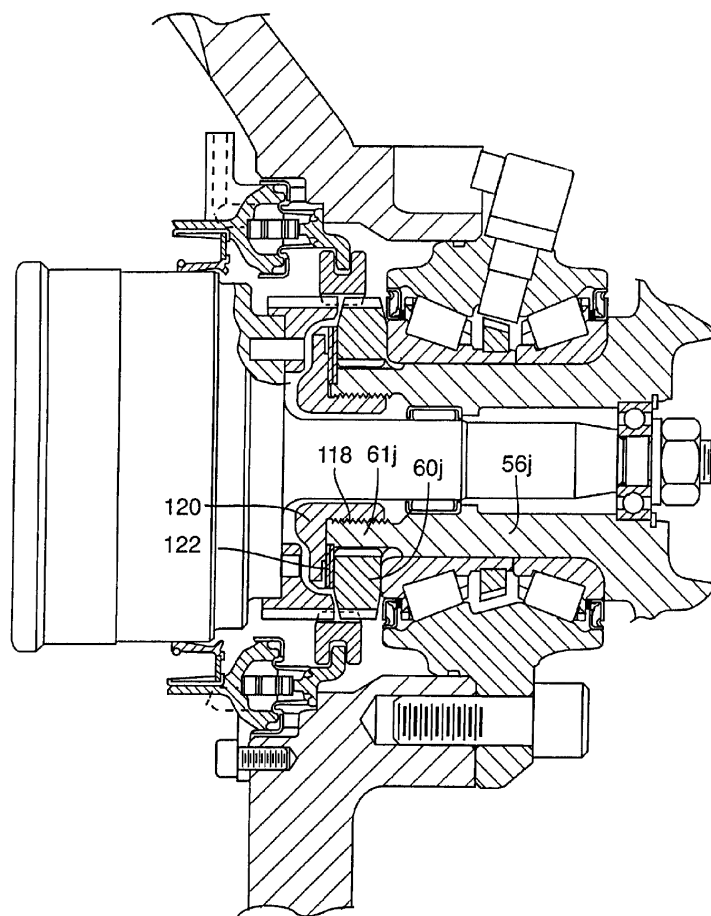



15a

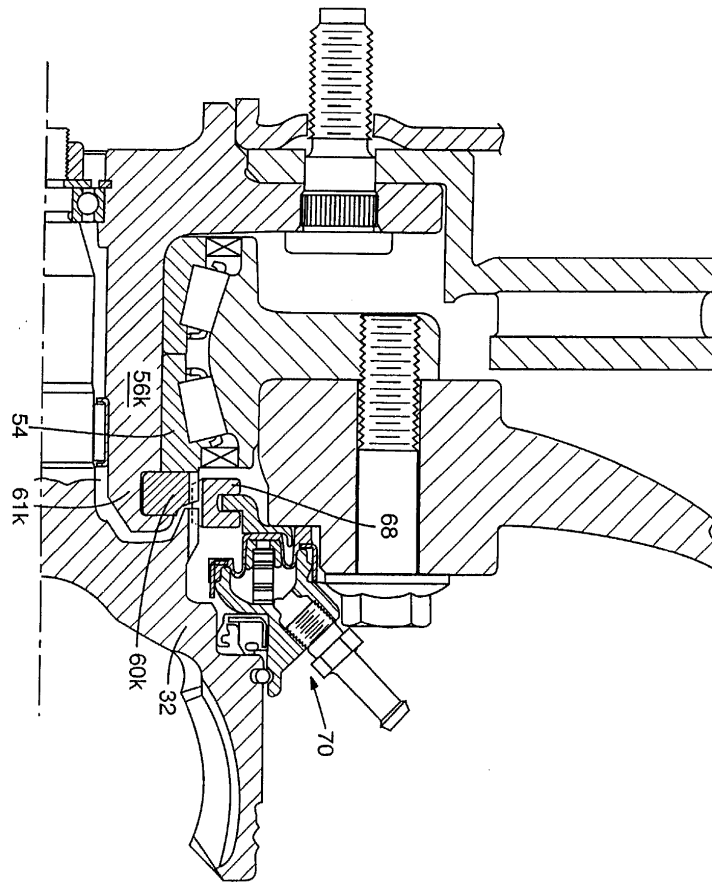

15b

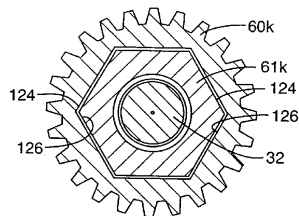

16a

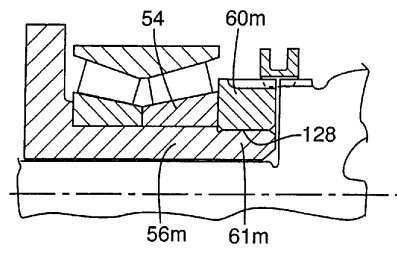

16b

