

Nov. 28, 1961

A. FERREIRA ET AL

3,010,549

ESCAPE SASH RELEASE MECHANISM

Filed April 27, 1959

3 Sheets-Sheet 1

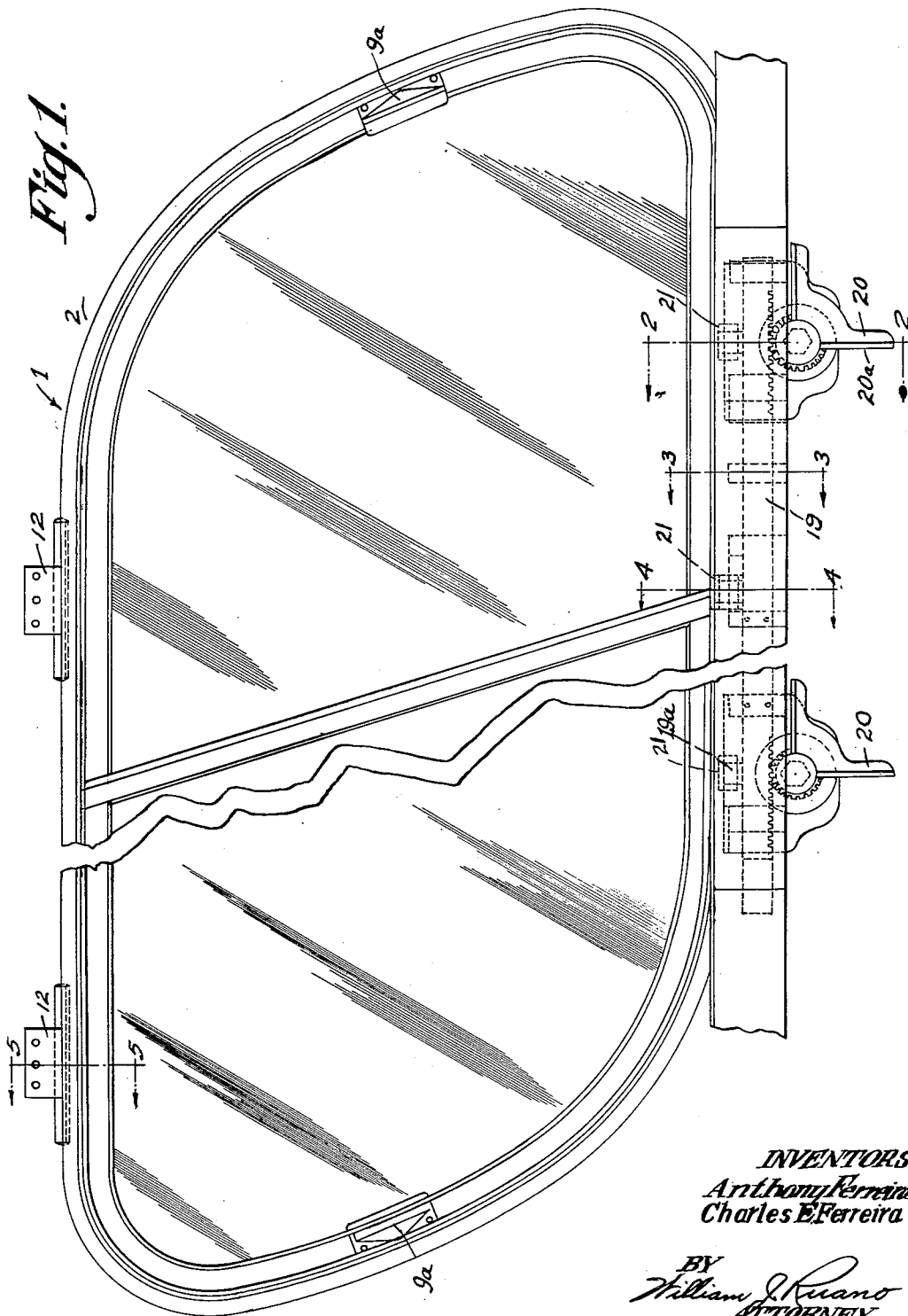

INVENTORS
Anthony Ferreira
Charles E. Ferreira

BY
William J. Ruano
ATTORNEY.

Nov. 28, 1961

A. FERREIRA ET AL

3,010,549

ESCAPE SASH RELEASE MECHANISM

Filed April 27, 1959

3 Sheets-Sheet 2

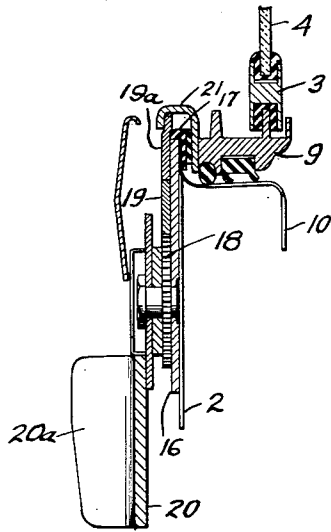

Fig. 2.

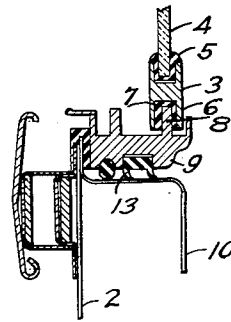

Fig. 3.

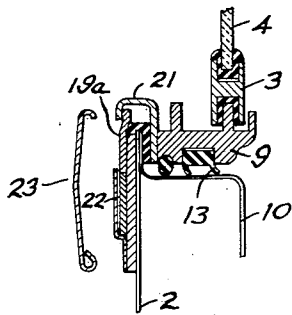

Fig. 4.

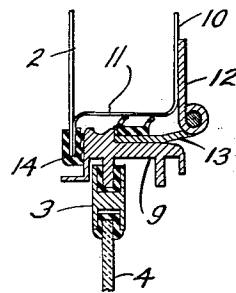

Fig. 5.

INVENTORS
Anthony Ferreira
BY *Charles E. Ferreira*
William J. Ruano
ATTORNEY.

Nov. 28, 1961

A. FERREIRA ET AL

3,010,549

ESCAPE SASH RELEASE MECHANISM

Filed April 27, 1959

3 Sheets-Sheet 3

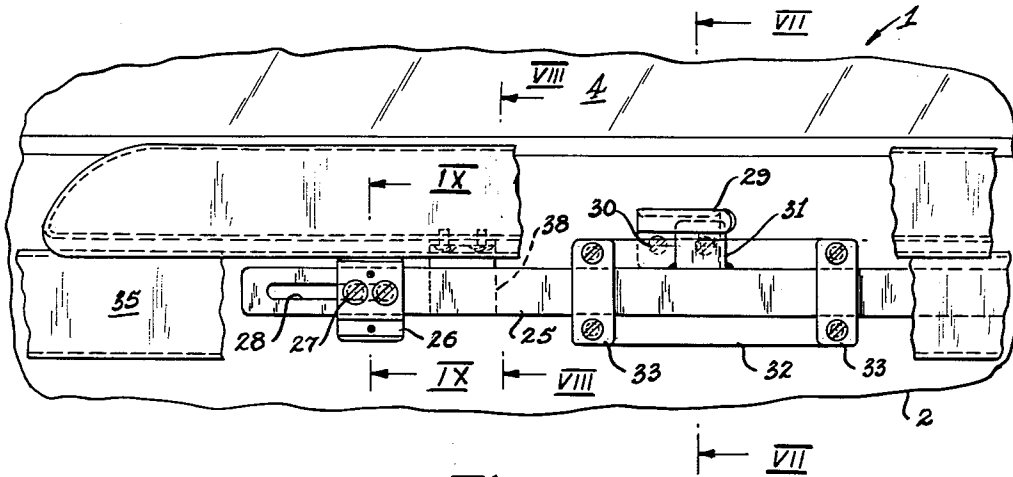

Fig. 6.

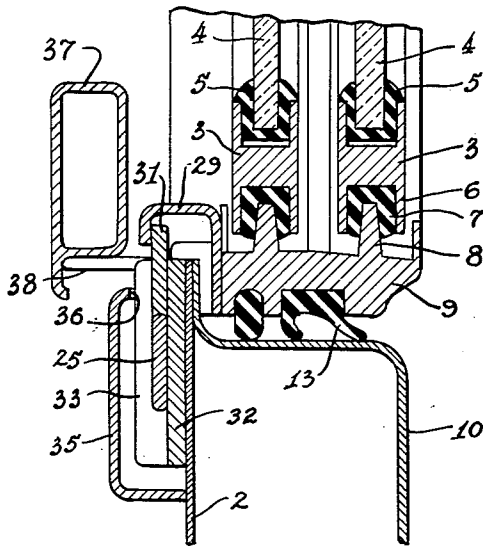

Fig. 7.

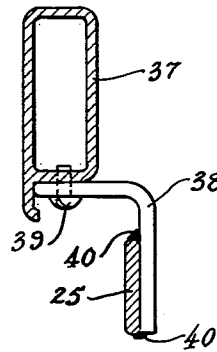

Fig. 8.

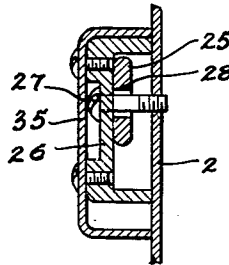

Fig. 9.

INVENTORS
Anthony Ferreira
Charles E. Ferreira

BY William J. Ruano
ATTORNEY.

1

3,010,549

ESCAPE SASH RELEASE MECHANISM

Anthony Ferreira, Allentown, Pa., and Charles E. Ferreira, Oakland, Calif., assignors to Transportation Sash Company, Inc., Tipton, Pa.

Filed Apr. 27, 1959, Ser. No. 809,023

3 Claims. (Cl. 189—64)

This invention relates to an escape sash release mechanism for a vehicle, such as a bus or train or for other conveyances, such as planes and, more particularly relates to a latching or locking mechanism therefor.

It is conventional practice on buses, for example, to provide a plurality of individual sashes, at least one of which is an escape sash which is hinged or otherwise pivotally mounted on one of its edges so that it may be swung out of the window opening to provide an emergency exit in case of an accident.

An outstanding disadvantage of conventional locking or latching mechanisms, particularly for long or wide sashes as used in streamlined buses, and the like, is that the handles for operating such latches generally are not placed conveniently with respect to the seating arrangement, furthermore they are usually difficult to operate since the operator must overcome spring-loaded latches, or must pull the latch toward himself which often times is impossible, particularly when the weight of the passengers is exerted on such handles, for example, when the bus is in a tilted position as the result of a skid.

A further disadvantage of such conventional prior art is that latches and their handles project considerably from the inside panel and provide obstructions which are somewhat dangerous and which, by accidental movements of the passengers, might cause accidental unlatching of the escape sash.

An object of the present invention is to provide a novel escape sash release mechanism which is devoid of the above named disadvantages and which may be operated at any number of positions which may be selected to correspond to any seating arrangement.

A further object of the present invention is to provide a relatively inexpensive sash release mechanism having a minimum number of parts which are rather simple in construction and in assembly and which will not project appreciably inwardly of the body panel so as to constitute a dangerous obstruction.

A still further object of the invention is to provide an escape sash release mechanism which, in the closed position, will provide a very tight, weather proof seal with the window.

Other objects and advantages of the invention will become apparent from a study of the following description taken with the accompanying drawings wherein:

FIG. 1 is a side, elevational view of a bus window of the escape type wherein parts are shown broken away, and embodying a latching mechanism according to the principles of the present invention;

FIG. 2 is an enlarged, vertical, cross-sectional view taken along line 2—2 of FIG. 1 showing the operating handle and the mechanism in the latched position;

FIG. 3 is an enlarged, vertical, cross-sectional view taken along line 3—3 of FIG. 1;

FIG. 4 is an enlarged vertical, cross-sectional view taken along line 4—4 of FIG. 1;

FIG. 5 is an enlarged, vertical, cross-sectional view taken along line 5—5 of FIG. 1 showing one of the hinges for pivotally mounting the window sash;

FIG. 6 is an elevational view, taken from the inside of a bus, of a modification showing a slide bolt arrangement;

2

FIG. 7 is an enlarged cross-sectional view taken along line VII—VII of FIG. 6;

FIG. 8 is an enlarged, cross-sectional view of the lock bar taken along line VIII—VIII of FIG. 6; and

FIG. 9 is an enlarged, cross-sectional view taken along line IX—IX of FIG. 6.

Referring more particularly to FIGS. 1 and 2 of the drawing, numeral 1 denotes an escape window of relatively wide or long construction in order to permit greater viewing by the passengers, which window is pivotally mounted in a window opening in the body panel 2 of the vehicle. The escape window 1 comprises frames 3 for supporting a pair of relatively slidable glass panels 4 sealed in the frames 3 by a glazing rubber seal 5. By grasping handles 9a the front and rear sashes may each be opened at least about 9 inches. The outer perimeter of the frame 3 is provided with a channel-like cross-section 6 in which is provided weather stripping 7. Guiding movements of frames 3 are provided by the sash frame 9 through integral ribs, such as 8.

As shown in FIG. 1, at least two, and preferably three hinges 12 are secured to the outside of body panel 2, one leaf of which hinges is secured to the outside portion 10, as shown more clearly in FIG. 5, whereas the other leaf of each hinge, namely 13, is integrally secured to the frame 9. Weather stripping 13 is provided between the last mentioned leaf and the sill portion 11. Thus when the sash is in the closed position, as shown in FIG. 5, a weather-tight seal will be provided, which seal is augmented by weather stripping 14 on the inside perimeter of the window opening which sealingly engages the sash frame 9.

The construction of the sash and hinged mounting thereof, as described hereinbefore, is well known in the art.

The present invention is shown more clearly in FIGS. 2, 3 and 4 and embodies a latching or locking mechanism operable at a plurality of longitudinally spaced points of the window. Referring more particularly to FIG. 2, numeral 16 denotes a base plate which provides a bearing and guide for rack 19 and welded ears 19a. A gear or pinion 18 is rotatably mounted on plate 16 and is rotated by means of a handle 20 rigidly connected to the gear so that turning movement of the flanged portion 20a of handle 20 will effect turning of the gear 18 which will effect longitudinal sliding movements of the rack 19 engaging the teeth of gear 18. The rack 19 extends substantially along the entire length of the window and is provided, at spaced intervals, with upstanding ears 19a which are adapted to project inside of a bracket or keeper 21. Preferably three ears and three corresponding brackets or keepers 21 are provided at spaced intervals along the length of the window, as shown in FIG. 1, although it will be apparent that a greater or smaller number may be used if desired. By turning the handle clockwise through an angle of 90° the ears 19a may be moved from the latched position to the unlatched position with respect to keepers or brackets 21, in which event it will be possible to push the frame outwardly about hinges 12 as a pivot and thus permit escape of the passengers in the event of an emergency. Brackets 21 are preferably flared along their end portions, or if desired, the end portions of ears 19a may be flared, so as to provide an easier introduction of the ear portion into the bracket and a gradual camming action so as to provide a greater compression of the seal 17, therefore a more weather-tight connection or seal. A plurality of gears, such as 18, and handles such as 20 are provided at selected longitudinally spaced points to correspond to the seats.

A longitudinal heater duct panel 23 is provided for

conducting heat along and inside the panel, as shown more clearly in FIG. 4.

FIGS. 6 to 9 inclusive show a modification of the invention embodying a lock bolt arrangement which is cheaper to manufacture and which takes less space in the bus body. Double panes 4, 4 of glass are mounted in window frame structures 3 and sealed to sash frame 9 which, in turn, is sealed to the outside portion 10, substantially as described hereinabove. A lock bolt 25 is mounted for horizontal sliding movement on the inside of the bus body and is guided, at one end portion, by means of a check block 26 which is held fast to the body panel 2 by means of bolts 27, as shown more clearly in FIG. 9. The shanks of the two bolts 27 extend through a slot 28 in bolt 25 and serve as stop elements for limiting the horizontal sliding movement of the bolt 25. Cover 35 is threadedly connected to a check block 26 which is rigidly held with respect to panel 2. An integral lug or ear 31, welded or otherwise integrally formed on the lock bolt 25, extends vertically upwardly and is adapted to be slid into and out of latching or locking engagement with a bolt cam 29 which, by means of screws 30, is rigidly fastened to sash frame 9. Guide base 32 is secured to base brackets 33 by means of screws or bolts and serves to horizontally guide the lock bolt 25. Cover 35 is provided with cut-outs 36 to allow for movement of lock bolt 25.

An elongated lock bar or handle 37 is rigidly connected to lock bolt 25 by means of screws 39 and weld 40 as shown more clearly in FIG. 8. Thus handle 37 is of such shape as to easily grasp to move the lock bolt into locking or unlocking position relative to sash frame 9.

It should be noted that the fragmentary view illustrated in FIG. 6 shows only a portion of the lock bolt assembly. The complete assembly included a plurality of slots 28, check blocks 26, lugs 31, bolt cams or catches 29 and guide bases 32, preferably three of each of these, as shown in FIG. 1.

Thus it will be seen that I have provided an efficient escape sash mechanism which may be quickly operated by passengers at any of a plurality of longitudinally spaced points; furthermore I have provided a latching mechanism which is movable entirely in the plane of the bus panel, instead of at right angles thereto, therefore which can be opened regardless of the amount of tilt of the bus in case of an accident; furthermore, I have provided a locking mechanism which does not provide an appreciable obstruction and which is constructed of simple, inexpensive parts which may be cheaply assembled and mounted and which insure a weather-tight seal when the window is in the closed position.

While we have illustrated and described several specific embodiments of our invention, it will be understood that

these are by way of illustration only, and that various changes and modifications may be made within the contemplation of our invention and within the scope of the following claims.

We claim:

1. In combination with a window pivotally mounted, at its top edge, to the frame defining a window opening in a bus body panel, a base plate portion of said frame projecting upwardly so as to overlap, in spaced relationship, the bottom edge portion of said window, resilient sealing means between said base plate portion and said bottom edge portion of the window, a plurality of horizontally spaced keepers secured to said bottom edge portion of the window, each including a forwardly and downwardly extending hook portion of substantially inverted U-shaped cross section, an elongated, horizontally extending rack having a plurality of integral upstanding ears spaced horizontally to correspond to the spacing of said keepers, a plurality of guide means each in the form of top and bottom guide elements slidably engageable with the top and bottom edges of said rack and including vertically extending outer members for confining the rack inwardly towards said bus panel for supporting said rack for horizontal movement in opposite directions, said keepers and ears including cam means to effect compression of said sealing means as said ears are latched by said keepers, and operating means movable in a plane closely parallel to said base plate portion and exposed to the interior of the bus whereby in case of accidental tilt of the bus resulting in exertion of weight by passengers lying on said window, said operating means will still be operable.

2. The combination recited in claim 1 wherein said rack includes gear teeth and wherein said operating means comprises a plurality of pinions engageable with said rack teeth at horizontally spaced positions, a quadrant shaped handle for each pinion and located underneath said rack for rotating the pinion through only 90 degrees to effect unlatching of said ears from said keepers.

3. The combination as recited in claim 1 wherein said operating means comprises a handle rigidly secured to said rack and extending inwardly of and parallel thereto along a substantial portion of the length thereof and movable horizontally in opposite directions to effect latching and unlatching movements of said keepers and ears.

References Cited in the file of this patent

UNITED STATES PATENTS

1,605,127	Mayo	Nov. 2, 1926
2,102,250	Zeeb et al.	Dec. 14, 1937
2,153,088	Knell	Apr. 4, 1939
2,231,530	Edwards	Feb. 11, 1941
2,821,770	Gruber	Feb. 4, 1958
2,830,843	Seabury et al.	Apr. 15, 1958