

1,001,922.

B. BERTKE.  
UNLOADING APPARATUS.  
APPLICATION FILED DEC. 22, 1910.

Patented Aug. 29, 1911.

3 SHEETS—SHEET 1.

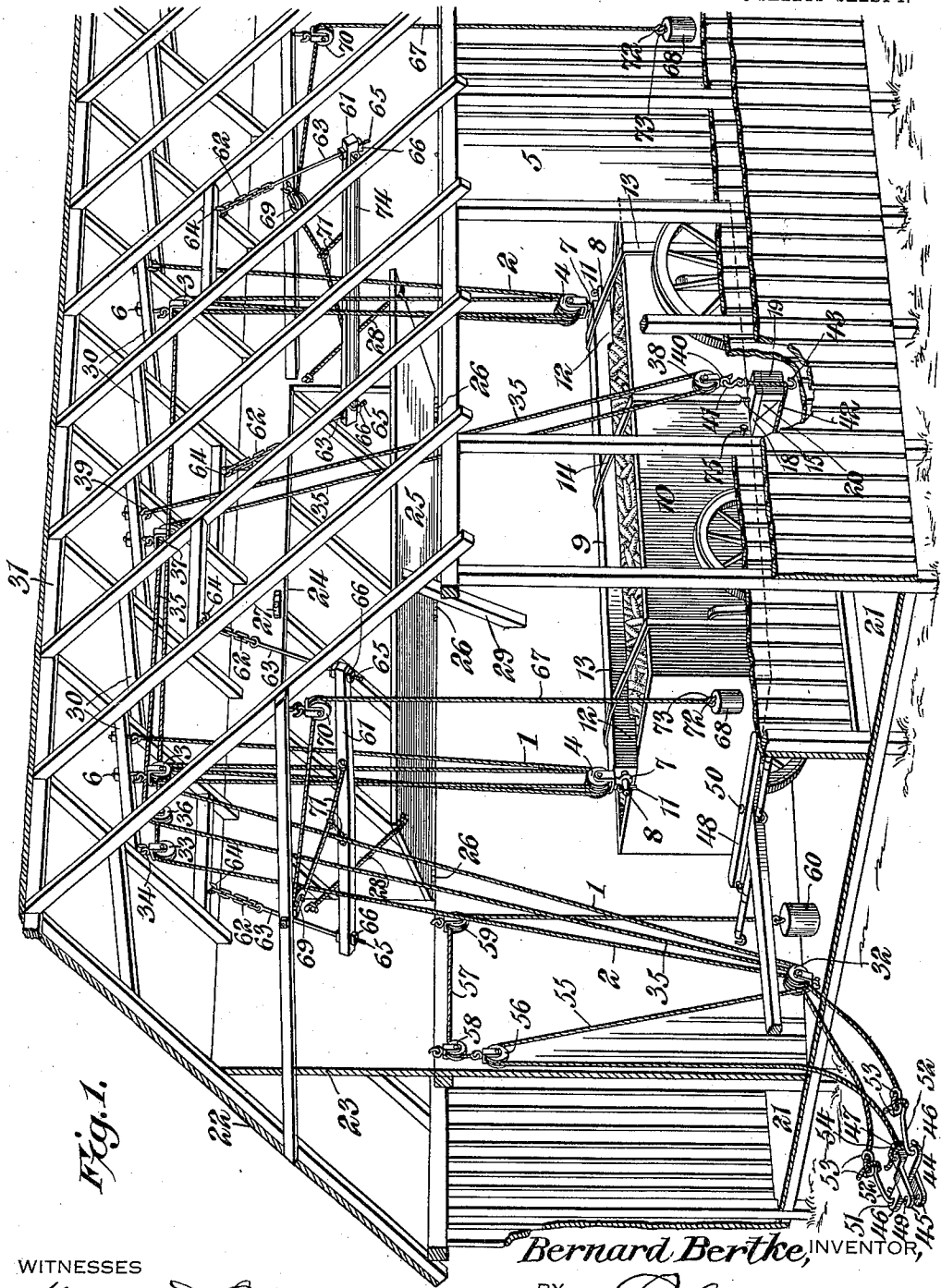

Fig. 1.

WITNESSES  
*Howard D. Ott.*  
*J. J. Riley.*

*Bernard Bertke*, INVENTOR,

BY *E. G. Siggers*

ATTORNEY

B. BERTKE.  
 UNLOADING APPARATUS.  
 APPLICATION FILED DEC. 22, 1910.

1,001,922.

Patented Aug. 29, 1911.

3 SHEETS—SHEET 2.

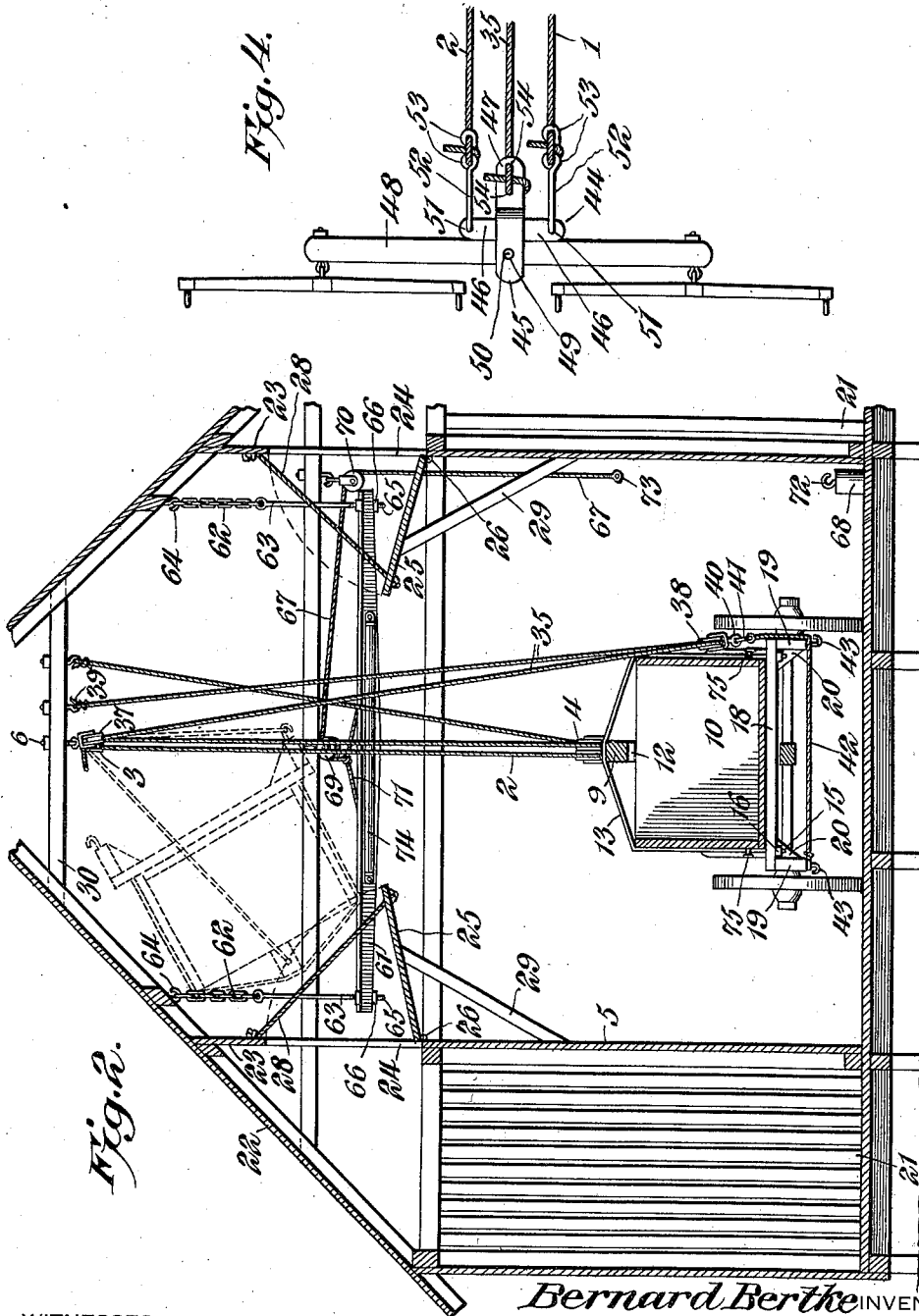

WITNESSES  
*Howard Dorr*  
*J. H. Perry*

*Bernard Bertke* INVENTOR,

BY *E. G. Siggers*

ATTORNEY

B. BERTKE.  
 UNLOADING APPARATUS.  
 APPLICATION FILED DEC. 22, 1910.

1,001,922.

Patented Aug. 29, 1911.

3 SHEETS—SHEET 3.

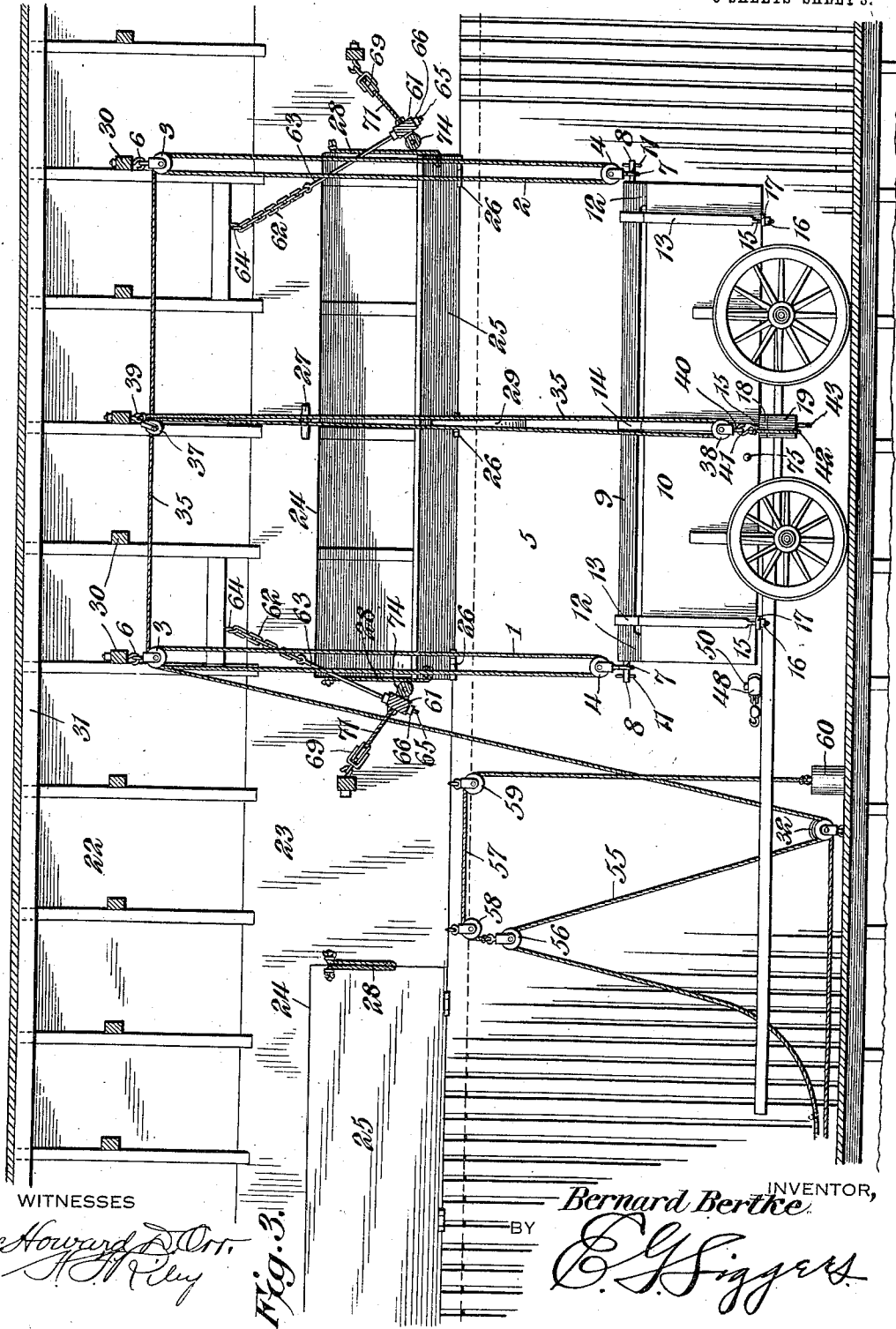

WITNESSES

*Howard D. Orr,*  
*H. M. Riley*

Fig. 3.

BY

*Bernard Bertke* INVENTOR,  
*E. J. Siggers*

ATTORNEY

# UNITED STATES PATENT OFFICE.

BERNARD BERTKE, OF VICTORIA, OHIO.

UNLOADING APPARATUS.

1,001,922.

Specification of Letters Patent. Patented Aug. 29, 1911.

Application filed December 22, 1910. Serial No. 598,795.

*To all whom it may concern:*

Be it known that I, BERNARD BERTKE, a citizen of the United States, residing at Victoria, in the county of Mercer and State of Ohio, have invented a new and useful Unloading Apparatus, of which the following is a specification.

The invention relates to improvements in unloading apparatus.

10 The object of the present invention is to improve the construction of unloading apparatus, more especially that shown and described in Patent No. 961,336, granted to me June 14, 1910, and to provide a simple, efficient and comparatively inexpensive apparatus, designed for use in corn cribs and various other places, and adapted to elevate a wagon body from its running gear and tilt the wagon body in an elevated position for discharging its contents into a bin or other receptacle, and capable of enabling the work incident to the hoisting and tilting of the wagon body to be performed by the horses or other draft animals of the wagon, whereby 25 a wagon may be easily and quickly unloaded by a boy old enough to drive a team.

A further object of the invention is to provide an unloading apparatus of this character, adapted to be readily transferred from one portion of a corn crib to another, so that all of the bins of a corn crib of any size may be filled with the apparatus.

30 With these and other objects in view, the invention consists in the construction and novel combination of parts hereinafter fully described, illustrated in the accompanying drawings, and pointed out in the claims hereto appended; it being understood that various changes in the form, proportion, size and minor details of construction, within the scope of the claims, may be resorted to without departing from the spirit or sacrificing any of the advantages of the invention.

45 In the drawings:—Figure 1 is a perspective view of the hoisting apparatus, constructed in accordance with this invention and shown installed in a corn crib. Fig. 2 is a transverse sectional view of the same. Fig. 3 is a longitudinal sectional view of the same. Fig. 4 is an enlarged plan view, showing the clevis connected with the doubletree and the hoisting and dumping ropes.

Like numerals of reference designate corresponding parts in all the figures of the drawings. 55

In the accompanying drawings in which is illustrated the preferred form of the apparatus, 1 and 2 designate hoisting ropes or cables, rove through upper and lower 60 double pulley blocks 3 and 4 to form front and rear falls. The pulley blocks are each provided with a pair of sheaves, and the upper pulleys or blocks are detachably hung within a corn crib 5 by hanging devices 6, 65 which may consist of hook bolts, as illustrated in the accompanying drawings, but any other preferred form of hanger may be employed for this purpose. The lower double pulley blocks are provided with depending 70 bearing eyes 7, detachably receiving terminal pivots 8 of a central longitudinal beam 9, which is detachably secured to the top of a wagon body or bed 10. The pivots 8 project from the ends of the beam, and the bearing 75 eyes 7 are retained on the same by means of removable keys 11, or other suitable fastening means.

The longitudinal beam 9, which is applied to the wagon body or bed at the beginning of the season, is preferably provided with enlarged ends 12, which are seated upon the upper edges of the ends of the wagon body or bed, and the said beam is held in position on the same by end straps 13 85 and an intermediate strap 14. The metallic straps 13 and 14 are in the form of yokes and consist of vertical sides and a transverse connecting top portion, extending across the top of the wagon body and across the upper 90 edge of the longitudinal beam and inclined at each side of the same, as clearly shown in Fig. 2 of the drawings. The lower terminals 15 of the sides of the yokes are threaded for the reception of nuts 16, and are connected 95 with end transverse bars 17 and an intermediate transverse bar or cleat 18. The end transverse bars preferably consist of relatively thin metallic pieces, and the intermediate cleat 18, which may be constructed of 100 any suitable material, preferably consists of a wooden bar or piece having projecting ends and provided with depending portions 19, braced by blocks 20, secured to the lower face of the intermediate cleat and to the 105 inner faces of the depending blocks or pieces

19. After the season or period in which the wagon is employed for hauling corn, the longitudinal beam and the metallic straps may be detached.

5 Although the apparatus is shown applied to a corn crib, it may be advantageously employed for any analogous purpose where it is desired to unload a wagon by elevating the body or bed and tilt the latter to discharge its contents.

10 The corn crib 5 may be of any desired size, and it is provided at opposite sides with slatted bins 21, the inclined sides of the roof 22 extending upwardly from the outer side walls of the bins, which are provided at 15 their inner walls with extensions 23. The extensions 23 wall the bins to the roof and adapt it to exclude chickens, birds and the like to prevent them from eating the corn after it has been placed in the bins. The 20 vertical extension 23 of the inner walls of the bins are provided with openings 24, which are normally closed by doors 25, hinged at their lower edges at 26 and adapted to be supported in an inclined position, as 25 illustrated in the accompanying drawings, to form chutes for directing the corn into the bins, as it is discharged from the wagon body or bed. The combined doors and 30 chutes 25 are secured in their closed position by pivot buttons 27, or other suitable fastening means, and they are preferably supported in their inclined position by end flexible connections 28 and an intermediate inclined brace or support 29. The flexible 35 supporting connections 28 may be constructed of any suitable material, and they are secured to the outer face of the combined door and chute 25 and to the outer face of the extension 23. The unloading apparatus is supported from the rafters, and the hanging devices 6 are secured to horizontal cross pieces 30, nailed or otherwise secured to the rafters. 40 When, however, there is sufficient space to admit of the tilting of the wagon body, the hanging devices may be mounted directly on 45 the ridge pole 31.

The front hoisting rope 1 extends downwardly from its upper pulley 3 to a lower 50 triple pulley 32, and the rear hoisting rope 2 extends from its upper pulley longitudinally of the apparatus to a guide pulley 33, and it then passes downwardly therefrom to the triple pulley 32. The guide pulley 33 is 55 located above and slightly in rear of the triple pulley 32, and it is detachably supported by a hanging device 34, consisting of a hook bolt. The triple pulley also receives a dumping rope or cable 35, extending upwardly from the triple pulley at an inclination and passing over a guide pulley 36 and 60 extending rearwardly therefrom to an intermediate upper pulley 37. The dumping rope is looped to form a fall, and it carries a lower 65 intermediate pulley 38 and is detachably se-

cured at its inner end adjacent to its upper pulley 37 by a hanger 39, consisting of a hook bolt. The upper pulleys 36 and 37 are detachably supported by hanging devices, consisting of hook bolts or other suitable 70 hangers.

The lower pulley of the dumping rope or cable is provided with a depending eye 40, adapted to be engaged by one of the terminal hooks 41 of a short flexible connection 42, 75 preferably consisting of a piece of rope or cable, and extending across the wagon body or bed and passing beneath the same. The flexible connection 42 is arranged beneath the intermediate cleat, and the depending 80 portions 19 thereof are equipped with depending hooks 43. One of the terminal hooks 41 of the flexible connection 42 is linked into one of the depending hooks 43, and the other end of the flexible connection 85 42 extends upwardly at the opposite side of the wagon body to the eye 40 of the pulley 38 and is hooked into the said eye. This particular construction enables the dumping rope to be connected with the wagon body 90 or bed at either side thereof, and the passing of the flexible connection 42 beneath the wagon body together with the projecting terminals of the intermediate cleat and the depending end portions thereof enable the 95 wagon body or bed to be tilted or partially rotated on its pivots a sufficient distance to completely discharge its contents, as clearly illustrated in dotted lines in Fig. 2 of the 100 drawings.

The outer terminals of the dumping and hoisting ropes are connected with a clevis 44, which may consist of a casting or be constructed in any suitable manner. The clevis 105 is composed of a pair of spaced forwardly projecting upper and lower arms or portions 45, a pair of laterally extending arms or portions 46 and a rearwardly extending attaching portion 47. The upper and lower 110 front arms 45 are spaced apart to receive the doubletree 48, and are provided with perforations 49 to receive the pivot pin 50 thereof. In practice the wagon to be unloaded is driven into the corn crib beneath 115 the hoisting apparatus, and the pin 50 of the doubletree is removed and the team is connected with the clevis 44 by securing the doubletree 48 between the front arms or portions 45. The team may then be employed for hoisting the wagon body or bed 120 and for also tilting the same, as hereinafter fully explained.

The laterally extending arms 46 are provided at their terminals with perforations 125 51 for the reception of hooks 52 for detachably connecting the outer ends of the hoisting ropes to the clevis. The hooks 52 are provided at the inner ends of their shanks with spaced eyes 53, through which the 130 hoisting ropes extend, and the outer ter-

minals of the hoisting ropes are passed partially around the shanks and beneath the portions of the hoisting ropes, which pass through the eyes to form a hitch, whereby the hooks are adjustably and detachably secured to the outer ends of the hoisting ropes. This will enable the hoisting ropes to be readily adjusted should either of them stretch or shrink, and the wagon body may be lifted in a horizontal position without danger of spilling its contents. The rearwardly extending attaching portion 47 is centrally arranged, and it is provided with spaced openings 54 to receive the outer end of the dumping rope or cable, which is passed through the openings 54 and partially around the attaching portion and beneath that portion of the dumping rope extending between the openings 54, whereby the dumping rope is adjustably and detachably secured to the clevis.

As the hoisting ropes extend through the double pulleys and the dumping rope passes through the single pulleys, the falls of the hoisting ropes are composed of twice as many runs or stretches of the ropes than the fall of the dumping rope. The hoisting ropes will be fed out from their falls twice as fast as the dumping rope, and in order to compensate for this inequality of the hoisting and dumping ropes, the dumping rope is provided with the compensating loop 55, formed by passing the dumping rope through a yieldably supported pulley 56. The pulley 56 is secured to one end of a short rope 57, or other suitable flexible connection, arranged on a pair of over-head pulleys 58 and 59, and provided at its other end with a weight 60. As the clevis is drawn forwardly or outwardly by the team, the loop 55 is reduced, and the weight 60 is elevated, and when the clevis is returned to its initial position, the loop increases in size, the slack being taken up by the weight 60, which maintains the dumping rope taut while all three ropes are connected with the clevis. The over-head pulleys 58 and 59 are detachably supported by hook bolts, and the triple pulley is detachably connected with the floor of the corn crib by a hook and eye, or other suitable fastening means.

The operation of hoisting and dumping is a continuous one, the wagon body being elevated by the hoisting ropes, and while the wagon body is supported in such elevated position by opposite swings 61, the hoisting ropes are disconnected from the clevis and the dumping rope is operated to tilt the wagon body and dump the contents thereof. The swings 61, which are arranged to support the wagon body adjacent to the ends thereof, are each composed of a transverse bar and supporting sides consisting preferably of short upper chains 62 and lower

rods 63. The chains detachably engage supporting hooks 64, and the lower ends 65 of the rods 63 are threaded for the reception of nuts 66, which adjustably connect the transverse bar to the rods. The hooks 64 are located at points between the transverse planes of the supporting portions of the hoisting ropes, and the cross bars when moved outwardly to points beyond the supporting ropes arrange the sides of the swings in an inclined position to cause the swings to move inwardly by gravity, when free to do so. The swings are normally maintained out of the path of the wagon body by ropes 67, equipped at their outer ends with weights 68 and supported by central and side pulleys 69 and 70, and provided at their inner ends with branches 71, which are secured to the outer faces of the transverse bars of the swings at opposite sides of the center of the same. The pulleys 69 and 70 are detachably hung on hook bolts, or other suitable hangers, and the weight 68 is provided at the top with a hook 72, which engages a suitable eye 73 of the outer ends of the flexible connections 67.

After the wagon to be dumped is driven into the corn crib beneath the unloading apparatus, the hoisting rope falls, which hang vertically, are connected with the terminal pivots of the longitudinal bar of the wagon body. The weights 68 are then removed from the flexible connections 67, and the swings are permitted to move inwardly to the depending portions or falls of the hoisting ropes, and in order to prevent the latter from being worn through contact with the swings, the transverse bars thereof are equipped at their inner faces with longitudinal rollers 74, journaled in suitable bearings and extending substantially the entire length of the transverse bars of the swings. The team having been hitched to the clevis is started forward and the wagon body is lifted off its running gear and is elevated sufficiently high to permit the swings to move inwardly beneath the ends of the wagon body. The team is then backed sufficiently to permit the weight of the wagon body to rest upon and be supported by the swings. The hooks 52 of the hoisting ropes are then disconnected from the clevis and the team is stepped forward a short distance. This pulls upon the dumping rope and tilts the wagon body, which is also swung laterally to one side of the corn crib by the short flexible connection 42. The latter in this operation thus releases itself from one end of the intermediate cleat so as to pull upon the opposite side of the wagon body. As soon as the wagon body is dumped, the team is backed to slacken the dumping rope and permit the wagon body to drop back upon the swings. The hooks of the hoisting ropes are then connected with

the laterally extending arms of the clevis, and the weights 68 are attached to the flexible connection 67 so as to draw the swings outwardly when relieved of the weight of the wagon body. The team is stepped forward slightly to lift the wagon body clear of the swings to permit the weights to carry them from the ends of the wagon body, which is then lowered upon the running gear. This forward movement of the team also causes the wagon body to assume an upright position. The swings are automatic in their operation, their weight swinging them inwardly beneath the wagon body, and the weights 68 carrying them outward from beneath the wagon body.

A wagon load of corn may be quickly and easily dumped by one person, and as the operator is relieved of all labor incident to hoisting and tilting the wagon body the apparatus may be operated by a boy old enough to drive a team. Also as the hoisting is effected by the pulling of the team, the apparatus is capable of handling a wagon body with much greater rapidity than that of the aforesaid patent, in which the hoisting and dumping operations are performed by a rotary manually operated drum. Furthermore, the operator is not compelled to let go the reins of the team, and in backing and pulling may control the animals at the heads thereof and in replacing the wagon body on the running gear, the operator is in convenient position to guide the body to its seat, should the running gear not occupy a true central position beneath the hoisting mechanism.

The corn crib is designed to be equipped with suitably arranged hooks, so that the lower pulleys 4 of the hoisting ropes and the lower pulleys of the dumping rope may be hung to one side of the corn crib, so as to be out of the way while driving the wagon into position beneath the apparatus. The sides of the wagon body are also equipped with supporting pins 75, adapted to be engaged by the hooks 41 of the flexible connection 42 for holding the latter above the ground and in position for convenient use.

The unloading apparatus is supported entirely from the ropes and by employing several sets of hook bolts or hangers, it may be arranged at different points along a corn crib and may be employed for filling all the bins thereof. By transferring the cross rope or flexible connection 42 and the loop or fall of the dumping rope from one side of the wagon body to the other, the contents of the wagon body may be dumped into the bins at either side of the corn crib.

Having thus fully described my invention, what I claim as new and desire to secure by Letters Patent, is:—

1. An apparatus of the class described including hoisting ropes having spaced por-

tions for connection to a wagon body, a dumping rope, means for connecting the latter with a wagon body at the side thereof, and a clevis connected with the said ropes, whereby the wagon body may be elevated and then tilted through a continuous forward pulling operation.

2. An apparatus of the class described including hoisting ropes having spaced portions for connection to a wagon body, a clevis connected with the hoisting ropes, and means separate from the hoisting ropes and also connected with the clevis and operated by the same for tilting the wagon body after the latter has been elevated, whereby the wagon body may be elevated and dumped by a continuous forward pull.

3. An apparatus of the class described including hoisting ropes having spaced portions for connection to a wagon body, a dumping rope having means for connecting it with the wagon body, a clevis having a permanent connection with the dumping rope, and means for detachably connecting the hoisting ropes with the clevis to enable the dumping rope to be operated independently of the hoisting ropes after the wagon body has been elevated.

4. An apparatus of the class described including hoisting ropes provided with spaced supporting portions or falls having a plurality of runs or stretches, a dumping rope provided with a depending portion or fall of a less number of flights or stretches than the hoisting ropes, a clevis connected with the dumping and hoisting ropes, and yieldable means for looping the dumping rope for maintaining the latter taut.

5. An apparatus of the class described including hoisting ropes provided with spaced supporting portions or falls having a plurality of runs or stretches, a dumping rope provided with a depending portion or fall of a less number of flights or stretches than the hoisting ropes, a clevis connected with the dumping and hoisting ropes, and yieldable means for looping the dumping rope for maintaining the latter taut when all of the ropes are connected with the clevis, said hoisting ropes being detachable from the clevis to permit an independent operation of the dumping rope.

6. An apparatus of the class described including hoisting ropes provided with spaced supporting portions or falls having a plurality of runs or stretches, a dumping rope provided with a depending portion or fall of a less number of flights or stretches than the hoisting ropes, a clevis connected with the dumping and hoisting ropes, said dumping rope having a compensating loop, and yieldable means connected with the compensating loop for maintaining the dumping rope taut.

7. An apparatus of the class described in-

cluding hoisting ropes provided with spaced supporting portions or falls having a plurality of runs or stretches, a dumping rope provided with a depending portion or fall of a less number of flights or stretches than the hoisting ropes, a clevis connected with the dumping and hoisting ropes, said dumping rope having a compensating loop, a pulley receiving the compensating loop, a flexible connection connected at one end with the said pulley, a weight connected with the other end of such flexible connection, and guiding means for the flexible connection.

8. An apparatus of the class described including a longitudinal bar provided with pivots, means for securing the same to a wagon body, hoisting ropes having spaced portions provided with bearings to receive the said pivots, a clevis connected with the hoisting rope, and dumping mechanism also operated by the clevis and provided with means for connecting it to a wagon body.

9. An apparatus of the class described including a longitudinal bar having terminal portions adapted to rest upon the ends of a wagon body and provided at its ends with pivots, means for securing the longitudinal bar to the wagon body, hoisting ropes having spaced portions provided with pulleys, said pulleys having bearings to receive the said pivots, a clevis connected with the hoisting ropes, and dumping mechanism also operated by the clevis and provided with means for connecting it with a wagon body.

10. An apparatus of the class described including a longitudinal bar having terminal pivots and adapted to be arranged upon the upper edge of a wagon body, yokes for securing the longitudinal bar to the wagon body, a transverse cleat connected to one of the yokes and provided at opposite sides of the wagon body with projecting portions provided with fastening devices, hoisting ropes having spaced portions provided with bearings to receive the said pivots, a dumping rope, and a transverse flexible connection extending beneath the wagon body and provided at its terminals with means for engaging the dumping rope and one of the fastening devices of the said cleat.

11. An apparatus of the class described including a longitudinal beam adapted to be arranged upon the upper edges of a wagon body, a transverse cleat extending beneath the wagon body and provided with projecting terminals located at opposite sides of the wagon body and having depending portions, means for securing the longitudinal bar and the cleat to the wagon body, fastening devices carried by the depending portions of the cleat, hoisting ropes having means for connecting them to the longitudinal bar, a dumping rope, and a transverse flexible connection extending beneath the de-

pending portions of the cleat and provided at its ends with means for engaging one of the fastening devices of such portions and for connecting it to the dumping rope.

12. An apparatus of the class described including a longitudinal beam having terminal pivots and adapted to rest upon the upper edges of a wagon body, means for detachably securing the beam to the wagon body, hoisting ropes having spaced portions provided with pulleys, said pulleys having eyes receiving the pivots of the longitudinal bar, fastening devices detachably securing the eyes of the pulleys on the pivots of the bar, means for operating the hoisting ropes, and means for tilting the wagon body after the same has been elevated by the hoisting ropes.

13. An apparatus of the class described including hoisting ropes having spaced portions for connection with a wagon body, swings arranged to support the wagon body in an elevated position, and ropes connected with the swings and provided with weights for holding the swings normally out of the path of the wagon body, said weights being detachable to permit the swings to move inward beneath the wagon body.

14. An apparatus of the class described including hoisting ropes having spaced depending supporting portions for connection with a wagon body, swings supported at points between the transverse planes of the supporting portions of the ropes, means for holding the swings outward beyond the ropes and for releasing the swings to permit the latter to move inwardly beneath the wagon body when the latter is elevated.

15. An apparatus of the class described including hoisting ropes having spaced supporting portions, means for connecting the same with a wagon body, and swings hung at points between the spaced supporting portions of the hoisting ropes and provided with rollers arranged to bear against the supporting portions of the ropes when the swings are moved outwardly to points beyond the same.

16. An apparatus of the class described including hoisting ropes having spaced supporting portions, means for connecting the same with a wagon body, and swings composed of sides hung at points between the supporting portions of the hoisting ropes, and bottom cross bars connecting the sides and provided at their inner faces with longitudinal rollers arranged to bear against the hoisting ropes.

17. An apparatus of the class described including a pair of hoisting ropes having spaced supporting portions, a dumping rope, and a clevis having a permanent connection with the dumping rope and provided with spaced forwardly extending arms adapted to receive a whiffletree and having perfora-

tions for the pivot thereof, and means for detachably connecting the hoisting ropes to the clevis.

5 18. An apparatus of the class described including a pair of hoisting ropes having spaced supporting portions, a dumping rope, a clevis connected with the dumping rope and having laterally extending arms provided with perforations, and hooks detachably engaging the perforations of the said arms and connected to the hoisting ropes.

10 19. An apparatus of the class described including a pair of hoisting ropes having spaced supporting portions, a dumping rope, and a clevis composed of spaced forwardly extending arms adapted to receive a whiffle-tree and having perforations for the pivot thereof, a rearwardly extending attaching portion to which the dumping rope is secured, and laterally extending arms to which the hoisting ropes are connected.

15 20. An apparatus of the class described including a pair of hoisting ropes having spaced supporting portions, a dumping rope, a clevis having spaced openings receiving the dumping rope, the terminal portion thereof being passed around the sides of the clevis

and interposed between the same and that portion of the rope between the said openings to form a hitch, and means for connecting the hoisting ropes with the clevis. 30

21. An apparatus of the class described including hoisting ropes having spaced portions for connection with a wagon body, a dumping rope having means for connecting it to the wagon body, a clevis provided with spaced openings through which the dumping rope is passed to form a hitch, said clevis being also provided with laterally extending arms having perforations, hooks provided with spaced eyes through which the outer terminals of the hoisting ropes are passed to form a hitch, said hooks detachably engaging the perforations of the laterally extending arms to permit the hoisting ropes to be disconnected therefrom. 35 40 45

In testimony, that I claim the foregoing as my own, I have hereto affixed my signature in the presence of two witnesses.

BERNARD BERTKE.

Witnesses:

JOHN H. SIGGERS,  
DAVID R. WAGNER.

Copies of this patent may be obtained for five cents each, by addressing the "Commissioner of Patents Washington, D. C."