



(86) Date de dépôt PCT/PCT Filing Date: 2009/01/20
 (87) Date publication PCT/PCT Publication Date: 2010/07/22
 (45) Date de délivrance/Issue Date: 2012/07/24
 (85) Entrée phase nationale/National Entry: 2011/04/21
 (86) N° demande PCT/PCT Application No.: EP 2009/050581
 (87) N° publication PCT/PCT Publication No.: 2010/081559
 (30) Priorité/Priority: 2009/01/16 (US12/355,655)

(51) Cl.Int./Int.Cl. *F21S 4/00* (2006.01),
F21K 99/00 (2010.01)
 (72) Inventeurs/Inventors:
LI, EDDIE PING KUEN, CN;
LO, PAUL, CN;
LO, TEDDY YEUNG MAN, CN
 (73) Propriétaire/Owner:
HUIZHOU LIGHT ENGINE LTD., CN
 (74) Agent: RIDOUT & MAYBEE LLP

(54) Titre : FIL D'ECLAIRAGE DE DIODE ELECTROLUMINESCENTE MONOBLOC FORME D'UN SEUL TENANT ET UTILISATIONS ASSOCIEES

(54) Title: INTEGRALLY FORMED SINGLE PIECE LIGHT EMITTING DIODE LIGHT WIRE AND USES THEREOF

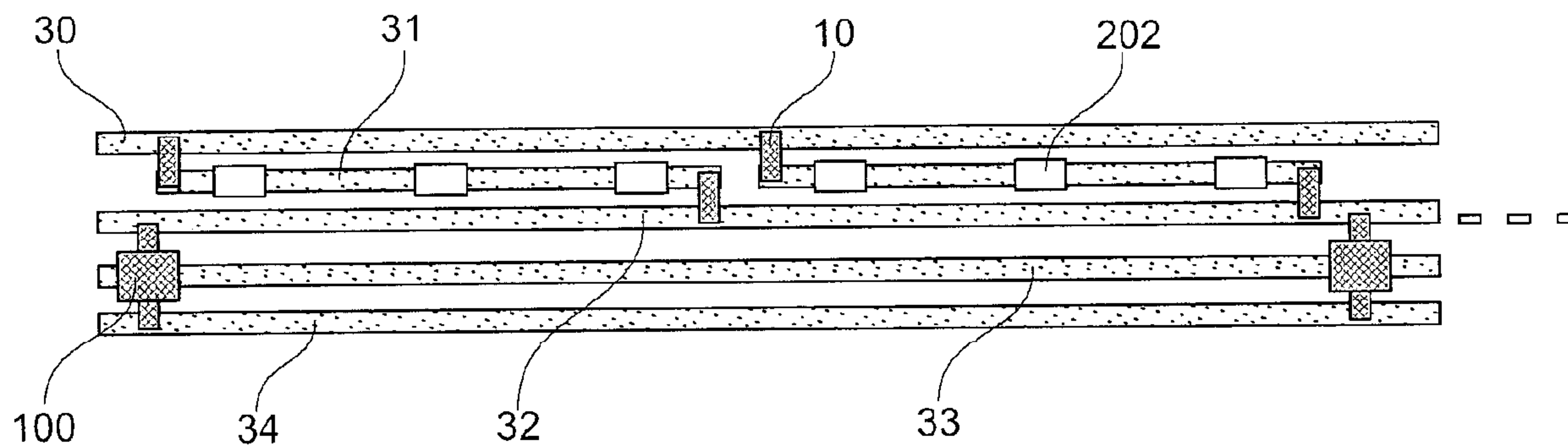

(57) **Abrégé/Abstract:**

An integrally formed single piece light emitting diode (LED) light wire that provides a smooth, uniform lighting effect from all directions of the LED light wire. The integrally formed single piece LED light wire includes a support substrate, a conductive base formed on the support substrate, the conductive bus comprising a plurality of conductive bus elements (30, 32, 33, 34), at least one conductive segment (31) arranged between the plurality of conductive bus elements (30, 32), the at least one conductive segment comprising at least one LED (202). The integrally formed single piece LED light wire may include built-in sensors/detectors (100) and/or a plurality of LED modules (2120) with individually controlled LEDs via microprocessors. The integrally formed single piece LED light wire may also include an interlocking alignment system which permits the coupling of at least two LED light wires. Further, a plurality of the integrally formed single piece LED light wires may create a lighting panel.



(12) INTERNATIONAL APPLICATION PUBLISHED UNDER THE PATENT COOPERATION TREATY (PCT)

CORRECTED VERSION

(19) World Intellectual Property Organization
International Bureau(43) International Publication Date
22 July 2010 (22.07.2010)

PCT

(10) International Publication Number
WO 2010/081559 A8

- (51) **International Patent Classification:**
F21S 4/00 (2006.01) F21Y 101/02 (2006.01)
- (21) **International Application Number:**
PCT/EP2009/050581
- (22) **International Filing Date:**
20 January 2009 (20.01.2009)
- (25) **Filing Language:** English
- (26) **Publication Language:** English
- (30) **Priority Data:**
12/355,655 16 January 2009 (16.01.2009) US
- (71) **Applicant (for all designated States except US):** **UNITED LUMINOUS INTERNATIONAL (HOLDINGS) LIMITED** [—/CN]; 6/F, Photonics Centre, 2 Science Park East Avenue, Hong Kong Science Park, Shatin, Hong Kong (SAR) (CN).
- (72) **Inventors; and**
- (71) **Applicants :** **LO, Paul** [GB/CN]; 19 Kent Road, Kowloon Tong, Hong Kong (CN). **LO, Teddy Yeung Man** [GB/CN]; 19 Kent Road, Kowloon Tong, Hong Kong (CN).
- (72) **Inventor; and**
- (75) **Inventor/Applicant (for US only):** **LI, Eddie, Ping, Kuen** [CN/CN]; Flat B, 9/F, Tower 4, Villa Athena, Ma On Shan, Hong Kong (SAR) (CN).
- (74) **Agent:** **MAIWALD PATENTANWALTS GMBH**; Korbinian Kopf, Elisenhof, Elisenstr. 3, 80335 Munich (DE).
- (81) **Designated States (unless otherwise indicated, for every kind of national protection available):** AE, AG, AL, AM, AO, AT, AU, AZ, BA, BB, BG, BH, BR, BW, BY, BZ, CA, CH, CN, CO, CR, CU, CZ, DE, DK, DM, DO, DZ, EC, EE, EG, ES, FI, GB, GD, GE, GH, GM, GT, HN, HR, HU, ID, IL, IN, IS, JP, KE, KG, KM, KN, KP, KR, KZ, LA, LC, LK, LR, LS, LT, LU, LY, MA, MD, ME, MG, MK, MN, MW, MX, MY, MZ, NA, NG, NI, NO, NZ, OM, PG, PH, PL, PT, RO, RS, RU, SC, SD, SE, SG, SK, SL, SM, ST, SV, SY, TJ, TM, TN, TR, TT, TZ, UA, UG, US, UZ, VC, VN, ZA, ZM, ZW.
- (84) **Designated States (unless otherwise indicated, for every kind of regional protection available):** ARIPO (BW, GH, GM, KE, LS, MW, MZ, NA, SD, SL, SZ, TZ, UG, ZM, ZW), Eurasian (AM, AZ, BY, KG, KZ, MD, RU, TJ, TM), European (AT, BE, BG, CH, CY, CZ, DE, DK, EE, ES, FI, FR, GB, GR, HR, HU, IE, IS, IT, LT, LU, LV, MC, MK, MT, NL, NO, PL, PT, RO, SE, SI, SK, TR), OAPI (BF, BJ, CF, CG, CI, CM, GA, GN, GQ, GW, ML, MR, NE, SN, TD, TG).
- Published:**
— with international search report (Art. 21(3))
- (48) **Date of publication of this corrected version:**
11 November 2010
- (15) **Information about Correction:**
see Notice of 11 November 2010

(54) **Title:** INTEGRALLY FORMED SINGLE PIECE LIGHT EMITTING DIODE LIGHT WIRE AND USES THEREOF

Fig. 18

(57) **Abstract:** An integrally formed single piece light emitting diode (LED) light wire that provides a smooth, uniform lighting effect from all directions of the LED light wire. The integrally formed single piece LED light wire includes a support substrate, a conductive base formed on the support substrate, the conductive bus comprising a plurality of conductive bus elements (30, 32, 33, 34), at least one conductive segment (31) arranged between the plurality of conductive bus elements (30, 32), the at least one conductive segment comprising at least one LED (202). The integrally formed single piece LED light wire may include built-in sensors/detectors (100) and/or a plurality of LED modules (2120) with individually controlled LEDs via microprocessors. The integrally formed single piece LED light wire may also include an interlocking alignment system which permits the coupling of at least two LED light wires. Further, a plurality of the integrally formed single piece LED light wires may create a lighting panel.

WO 2010/081559 A8

**INTEGRALLY FORMED SINGLE PIECE LIGHT EMITTING DIODE LIGHT WIRE AND
USES THEREOF**

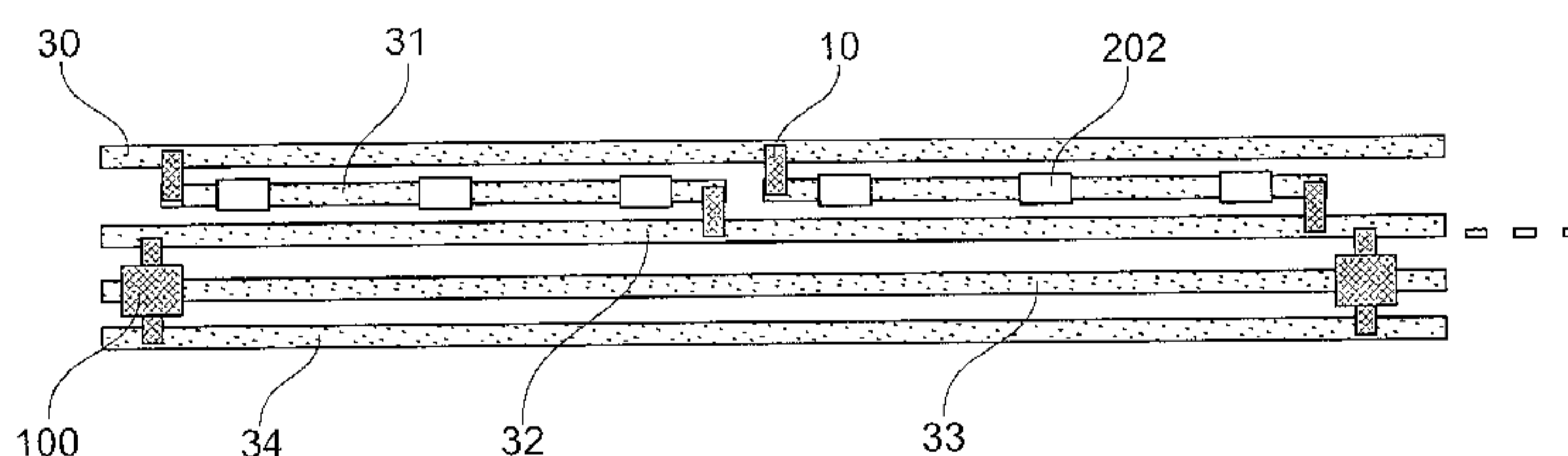
CROSS-REFERENCE TO RELATED APPLICATIONS

[0001] This PCT application claims priority to U.S. Serial No. 12/355,655, filed January 16, 2009, which is a continuation-in-part of U.S. Serial No. 11/854,145, filed September 12, 2007, which claims priority to U.S. Provisional Patent Application Serial No. 60/844,184, filed September 12, 2006, the entirety of which is incorporated herein by reference.

[0002] Throughout this application, several publications are referenced. Disclosure of these references in their entirety is hereby incorporated by reference into this application.

[0003] The present invention relates to light wires and, more specifically, an integrally formed single piece of light wire containing light emitting diodes ("LEDs"), and the uses of such LED light wire, wherein the LEDs and associated circuitry of the LED light wire are protected from mechanical damage and environmental hazards, such as water and dust.

BACKGROUND THE INVENTION

[0004] Conventional incandescent or LED light wires are commonly used in a variety of indoor and outdoor decorative or ornamental lighting applications. For example, such conventional light wires are used to create festive holiday signs, outline architectural structures such as buildings or harbors, and provide under-car lighting systems. These light wires are also used as emergency lighting aids to increase visibility and communication at night or when conditions, such as power outages, water immersion and smoke caused by fires and chemical fog, render normal ambient lighting insufficient for visibility.

[0005] Conventional LED light wires consume less power, exhibit a longer lifespan, are relatively inexpensive to manufacture, and are easier to install when compared to light tubes using incandescent light bulbs. Increasingly, LED light wires are used as viable replacements for neon light tubing.

[0006] As illustrated in FIGURE 1, conventional light wire 100 consists of a plurality of illuminant devices 102, such as incandescent light bulbs or LEDs, connected together by a flexible wire 101 and encapsulated in a protective tube 103. A power source 105 creates an electrical current that flows through the flexible wire 101 causing the illuminant devices 102 to illuminate and create an effect of an illuminated wire. The illuminant devices 102 are connected in series, parallel, or in combination thereof. Also, the illuminant devices 102 are connected with control electronics in such a way that individual illuminant devices 102 may be selectively switched on or off to create a combination of light patterns, such as strobe, flash, chase, or pulse.

[0007] In conventional light wires, the protective tube 103 is traditionally a hollow, transparent or semi-transparent tube which houses the internal circuitry (e.g., illuminant devices 102; flexible wire 101). Since there is an air gap between the protective tube 103 and internal circuitry, the protective tube 103 provides little protection for the light wire against mechanical damage due to excessive loads, such as the weight of machinery that is directly applied to the light wire. Furthermore, the protective tube 103 does not sufficiently protect the internal circuitry from environmental hazards, such as water and dust. As a result, these conventional light wires 100 with protective tube 103 are found unsuitable for outdoor use, especially when the light wires are exposed to extreme weather and/or mechanical abuse.

[0008] In conventional light wires, wires, such as flexible wire 101, are used to connect the illuminant devices 102 together. In terms of manufacturing, these light wires are traditionally pre-assembled using soldering or crimp methods and then encapsulated via a conventional sheet or hard lamination process in protective tube 103. Such manufacturing processes are labor intensive and unreliable. Furthermore, such processes decrease the flexibility of the light wire.

[0009] In response to the above-mentioned limitations associated with conventional light wires and the manufacture thereof, LED light strips have been developed with increased complexity and protection. These LED light strips consist of circuitry including a plurality of LEDs mounted on a support substrate containing a printed circuit and connected to two separate electrical conductors or bus elements. The LED circuitry and the electrical conductors are encapsulated in a protective encapsulant without internal voids (which includes gas bubbles) or impurities, and are connected to a power source. These LED light strips are manufactured by an automated system that includes a complex LED circuit assembly process and a soft lamination process. Examples of these LED light strips and the manufacture thereof are discussed in U.S. Patent Nos. 5,848,837, 5,927,845 and 6,673,292, all entitled "Integrally Formed Linear Light Strip With Light Emitting Diode"; U.S. Patent No. 6,113,248, entitled "Automated System For Manufacturing An LED Light Strip Having An Integrally Formed Connected"; and U.S. Patent No. 6,673,277, entitled "Method of Manufacturing a Light Guide".

[0010] Although these LED light strips are better protected from mechanical damage and environmental hazards, these LED light strips only provide one-way light direction, and are limited to two separate bus elements in its internal LED circuitry. Also, the manufacturing of such LED light strips remains expensive and time-consuming since these LED light strips at least require a protective encapsulant free of internal voids and impurities, as well as crimping each LED connector pin to the internal LED circuitry. Further, the lamination process makes these LED light strips too rigid to bend.

SUMMARY OF THE INVENTION

[0011] In light of the above, there exists a need to further improve the art. Specifically, there is a need for an improved integrally formed single piece LED light wire that is flexible and provides a smooth, uniform lighting effect from all directions of the integrally formed single piece LED light wire. Furthermore, there is also a need for an LED light wire with additional lighting functions which is manufactured by a low cost, time-efficient automated process.

[0012] An integrally formed single piece LED light wire, comprising a support substrate; a conductive base formed on the support substrate, the conductive base comprising a first, second, third and fourth conductive bus elements; at least one conductor segment arranged between the first and second conductive bus elements, the at least one conductor segment comprising at least one LED; and at least one sensor coupled to the third and fourth conductive bus elements, the third conductive bus element is adapted to transmit signals from the at least one sensor, and the fourth conductive bus is adapted to provide power to the at least one sensor.

[0013] According to an embodiment of the integrally formed single piece LED light wire, the second conductive bus element is a ground and the at least one sensor is additionally coupled to the second conductive bus element.

[0014] According to an embodiment of the integrally formed single piece LED light wire, includes an encapsulant completely encapsulating the support substrate, the conductive base, the at least one conductor segment and the at least one sensor. The encapsulant may include light scattering particles.

[0015] According to an embodiment of the integrally formed single piece LED light wire, includes a plurality of conductor segments, wherein the plurality of conductor segments comprising a plurality of LEDs connected in series.

[0016] According to an embodiment of the integrally formed single piece LED light wire, includes a plurality of conductor segments, wherein the plurality of conductor segments comprises a plurality of LEDs connected in series and parallel.

[0017] According to an embodiment of the integrally formed single piece LED light wire, the first, second, third and fourth conductive bus elements and the at least one conductor segment is made of braided wire.

[0018] An integrally formed single piece LED light wire, comprising a support substrate; first and second conductive bus elements formed on the support substrate, wherein the first conductive bus element is adapted to distribute power from a power

source, and the second conductive bus element is a ground; and at least two LED modules, each LED module comprising a microprocessor, at least one LED, power input and output connections, control signal input and output connections, and data input and output connections, wherein the control signal and data input connections of each LED module are coupled to the control signal and data output connections of an adjacent LED module, wherein the power input connection of a first LED module is coupled to the first conductive bus element, the power output connection of a second LED module is coupled to the second conductive bus element and the power input connections of every other LED module are coupled to the power output connections of adjacent LED modules.

[0019] According to an embodiment of the integrally formed single piece LED light wire, at least one LED module includes a plurality of LEDs, wherein the plurality of LEDs are selected from the group consisting of red, blue, green, and white LEDs.

[0020] According to an embodiment of the integrally formed single piece LED light apparatus, includes an encapsulant completely encapsulating the support substrate, the first and second conductive bus elements, and the at least two LED modules. The encapsulant may include light scattering particles.

[0021] According to an embodiment of the integrally formed single piece LED light wire, the first and second conductive bus elements is made of braided wire.

[0022] According to an embodiment of the integrally formed single piece LED light wire, the outer profile of the encapsulant comprises an alignment key and an alignment keyhole located at opposite sides of the integrally formed single piece LED light wire.

[0023] A lighting panel comprising a plurality of the integrally formed single piece LED light wires described in this application.

[0024] An integrally formed single piece LED light wire, comprising a support substrate; first and second conductive bus elements formed on the support substrate, wherein the first conductive bus element is adapted to distribute power from a power

source, and the second conductive bus element is a ground; and at least two LED modules, each LED module comprising a microprocessor, at least one LED, power input and output connections, control signal input and output connections, and data input and output connections, wherein the control signal and data input connections of each LED module are coupled to the control signal and data output connections of an adjacent LED module, wherein the power input connection of each LED module is coupled to the first conductive bus element and the power output connection of each LED module is coupled to the second conductive bus element.

BRIEF DESCRIPTION OF THE FIGURES

[0025] For the purposes of illustrating the present invention, the drawings reflect a form which is presently preferred; it being understood however, that the invention is not limited to the precise form shown by the drawings in which:

[0026] FIGURE 1 is a representation of a conventional light wire;

[0027] FIGURE 2 is a top view illustrating an integrally formed single piece LED light wire according to an embodiment of the present invention;

[0028] FIGURE 3 is a cross-sectional view of the integrally formed single piece LED light wire shown in FIGURE 2;

[0029] FIGURE 4A is a side view of an integrally formed single piece LED light wire according to another embodiment of the present invention;

[0030] FIGURE 4B is a top view of the integrally formed single piece LED light wire shown in FIGURE 4B;

[0031] FIGURE 5A is a cross-sectional view of the integrally formed single piece LED light wire shown in FIGURES 4A & 4B;

[0032] FIGURE 5B is a cross-sectional view of an integrally formed single piece LED light wire according to another embodiment of the present invention;

[0033] FIGURE 6A is an embodiment of a conductive base;

[0034] FIGURE 6B is a schematic diagram of the conductive base of FIGURE 6A;

[0035] FIGURE 7A is another embodiment of a conductive base;

[0036] FIGURE 7B is a schematic diagram of the conductive base of FIGURE 7A;

[0037] FIGURE 8A is another embodiment of a conductive base;

[0038] FIGURE 8B is a schematic diagram of the conductive base of FIGURE 8A;

[0039] FIGURE 9A is another embodiment of a conductive base;

[0040] FIGURE 9B is a schematic diagram of the conductive base of FIGURE 9A;

[0041] FIGURE 10A is another embodiment of a conductive base;

[0042] FIGURE 10B is a schematic diagram of the conductive base of FIGURE 10A;

[0043] FIGURE 11A is another embodiment of a conductive base;

[0044] FIGURE 11B is a schematic diagram of the conductive base of FIGURE 11A;

[0045] FIGURE 11C depicts an embodiment of a conductive base wrapped on a core prior to encapsulation;

[0046] FIGURE 12A depicts an embodiment of an LED mounting area of a conductive base;

[0047] FIGURE 12B depicts an LED mounted on the LED mounting area shown in FIGURE 12A;

[0048] FIGURE 13 depicts LED chip bonding in another embodiment of an LED mounting area;

[0049] FIGURE 14A depicts the optical properties of an integrally formed single piece LED light wire according to an embodiment of the present invention;

[0050] FIGURE 14B depicts a cross-sectional view of a dome-shaped encapsulant and the optical properties thereof;

[0051] FIGURE 14C depicts a cross-sectional view of a flat-top-shaped encapsulant and the optical properties thereof;

[0052] FIGURES 15A-C depict a cross-sectional view of three different surface textures of the encapsulant;

[0053] FIGURE 16A is a schematic diagram of an integrally formed single piece LED light wire according to an embodiment of the present invention;

[0054] FIGURE 16B depicts an embodiment of the integrally formed single piece LED light wire shown in FIGURE 16A;

[0055] FIGURE 16C is a block diagram illustrating the integrally formed single piece LED light wire shown in FIGURE 16B;

[0056] FIGURE 17A is a block diagram of an integrally formed single piece LED light wire according to another embodiment of the present invention;

[0057] FIGURE 17B is a cross-sectional view of the integrally formed single piece LED light wire shown in FIGURE 17A;

[0058] FIGURE 17C is a block diagram illustrating an integrally formed single piece LED light wire according to an embodiment of the present invention;

[0059] FIGURE 18 is a block diagram illustrating an integrally formed single piece LED light wire containing at least a sensor or detector according to an embodiment of the present invention;

[0060] FIGURE 19A is a schematic diagram of a full color integrally formed single piece LED light wire according to an embodiment of the present invention;

[0061] FIGURE 19B is a block diagram illustrating an embodiment of the integrally formed single piece LED light wire shown in FIGURE 19A;

[0062] FIGURE 20 is a schematic diagram of a control circuit for a full color integrally formed single piece LED light wire;

[0063] FIGURE 21 is a timing diagram for a full color integrally formed single piece LED light wire;

[0064] FIGURE 22A is a timing diagram for a full color integrally formed single piece LED light wire;

[0065] FIGURE 22B is a timing diagram for a full color integrally formed single piece LED light wire;

[0066] FIGURE 23 is a schematic diagram of an integrally formed single piece LED light wire containing a plurality of LED modules according to an embodiment of the present invention;

[0067] FIGURE 24 is a layout diagram of the integrally formed single piece LED light wire shown in FIGURE 23;

[0068] FIGURE 25A is a block diagram illustrating a lighting panel comprising a plurality of integrally formed single piece LED light wires with interlocking alignment system according to an embodiment of the present invention;

[0069] FIGURE 25B is a cross-sectional view of the lighting panel shown in FIGURE 25A; and

[0070] FIGURE 25C is a cross-sectional view of a lighting panel comprising a plurality of integrally formed single piece LED light wires according to another embodiment of the present invention.

DETAILED DESCRIPTION OF THE INVENTION

[0071] The present invention relates to an integrally formed single piece LED light wire containing a plurality of LEDs that are connected in series, parallel or a combination thereof on at least one conductive bus element which forms a mounting base or on at least two conductive bus elements mounted on a support substrate made of insulating material (e.g., plastic) to provide a combined mounting base. Both types of mounting base provides an (1) electrical connection, (2) a physical mounting platform or a mechanical support for the LEDs, and (3) a light reflector for the LEDs. The mounting base and LEDs are encapsulated in a transparent or semi-transparent encapsulant which may contain light scattering particles.

[0072] In one embodiment of the present invention, as shown in FIGURES 2 and 3, an integral single piece LED light wire, which includes a sub-assembly 310 comprising at least one LED 202 connected to a conductive base 201, the sub-assembly 310 is encapsulated within an encapsulant 303, and the conductive base 201 comprises one conductive bus element formed from a conductive material capable of distributing power from a power source. As shown in FIGURE 2, the LEDs 202 are connected in series. This embodiment offers the advantage of compactness in size, and allows the production of a long, thin LED light wire with an outer diameter of 3mm or less. The conductive base 301 is operatively connected to a power source 305 to conduct electricity.

[0073] In another embodiment, as illustrated in FIGURES 4A, 4B, and 5A, the present invention may be an integrally formed single piece LED light wire comprising a plurality of sub-assemblies 510. Each sub-assembly 510 consists of at least one LED 202 connected to a conductive base, wherein the conductive base 401 has two conductive bus elements 401A and 401B. The sub-assemblies 510 are encapsulated within an encapsulant 503. As shown, the LEDs 202 are connected in parallel. The conductive base 401 is operatively connected to a power source 405 to activate LEDs 202.

[0074] In another embodiment, as shown in FIGURE 5B, the present invention may include a plurality of sub-assemblies 701. Each sub-assembly 750 includes at least one LED 202 (for example, a SMD-On-Board LED) connected to a conductive base 94 having at least two conductive bus elements 94A and 94B, wherein the conductive base 94 is mounted on a support substrate 90.

[0075] AC or DC power from a power source, such as power source 405, may be used to power the integrally formed single piece LED light wire. Additionally, a current source may be used. Brightness may be controlled by digital or analog controllers.

[0076] The conductive base 94, 201, 401 extends longitudinally along the length of the integrally formed single piece LED light wire, and act as an (1) electrical conductor, (2) a physical mounting platform or a mechanical support for the LEDs 202, and (3) a light reflector for the LEDs 202.

[0077] The conductive base 201, 401 may be, for example, punched, stamped, printed, silk-screen printed, or laser cut, or the like, from a metal plate or foil to provide the basis of an electrical circuit, and may be in the form of a thin film or flat strip. The conductive bus elements of conductive base 94, 201, 401, and conductive segments (discussed below) may also be formed using rigid electrical conductive materials (such as metal rod, metal strip, copper plate, copper clad steel plate, metal strip, a rigid base material coated with an electrically conductive material, or the like), or flexible electrical conductive materials (such as thin metal strip, copper clad alloy wire, stranded wire, braided wire, or the like). Stranded wire or braided wire may be flat or round, and comprises a plurality of electrical conductive fine wires made of copper, brass, aluminum, or the like; such fine wires may be bare or coated with electrical conductive materials including, but not limited to, tin, nickel, silver, or the like. Metal, mentioned in this paragraph, may include copper, brass, aluminum, or the like. In a preferred embodiment, flat braided wire is used as conductive bus elements or conductive segments.

[0078] The conductive bus elements of conductive base 94 may be mounted on a support substrate 90 via adhesion, lamination, extrusion, or casting. The support substrate 90 may be made of rigid or flexible plastic, such as polyethylene terephthalate (PET), polyvinyl chloride (PVC), and thermoplastic polyurethane (TPU).

[0079] Additional circuitry, such as active or passive control circuit components (e.g., a microprocessor, a resistor, a capacitor), may be added and encapsulated within an encapsulant to add functionality to the integrally formed single piece LED light wire. Such functionality may include, but not limited to, current limiting (e.g., resistor 10), protection, flashing capability, or brightness control. For example, a microcontroller or microprocessor may be included to make the LEDs 202 individually addressable; thereby, enabling the end user to control the illumination of selective LEDs 202 in the LED light wire to form a variety of light patterns, e.g., strobe, flash, chase, or pulse. In one embodiment, external control circuitry is connected to the conductive base 94, 201, 401.

[0080] *First Embodiment of the Conductive Base*

[0081] In a first embodiment of the conductive base assembly 600, shown in FIGURE 6A, the base material of the conductive base 601 is preferably a long thin narrow metal strip or foil. In one embodiment, the base material is copper. A hole pattern 602, shown as the shaded region of FIGURE 6A, depict areas where material from the conductive base 601 has been removed. In one embodiment, the material has been removed by a punching machine. The remaining material of the conductive base 601 forms the circuit of the present invention. Alternatively, the circuit may be printed on the conductive base 601 and then an etching process is used to remove the areas 602. The pilot holes 605 on the conductive base 600 act as a guide for manufacture and assembly.

[0082] The LEDs 202 are mounted either by surface mounting or LED chip bonding and soldered, welded, riveted or otherwise electrically connected to the conductive base 601 as shown in FIGURE 6A. The mounting and soldering of the LEDs 202 onto the

conductive base 601 not only puts the LEDs 202 into the circuit, but also uses the LEDs 202 to mechanically hold the different unpunched parts of the conductive base 601 together. In this embodiment of the conductive base 601 all of the LEDs 202 are short-circuited, as shown in FIGURE 6B. Thus, additional portions of conductive base 601 are removed as discussed below so that the LEDs 202 are not short-circuited. In one embodiment, the material from the conductive base 601 is removed after the LEDs 202 are mounted.

[0083] *Second Embodiment of the Conductive Base*

[0084] To create series and/or parallel circuitries, additional material is removed from the conductive base. For example, additional portions of the conductive base are removed between the terminals of the LEDs 202 after the LEDs 202 are mounted on the conductive base; thereby, creating at least two conductors wherein each conductor is electrically separate, but then coupled to each other via the LEDs 202. As shown in FIGURE 7A, the conductive base 701 has an alternative hole pattern 702 relative to the hole pattern 602 depicted in FIGURE 6A. With the alternative hole pattern 702, the LEDs 202 (such as the three shown in FIGURES 7A and 7B) are connected in series on the conductive base 701. The series connection is shown in FIGURE 7B, which is a schematic diagram of the conductive base assembly 700 shown in FIGURE 7A. As shown, the mounting portions of LEDs 202 provide support for the conductive base 701.

[0085] *Third Embodiment of the Conductive Base*

[0086] In a third embodiment of the conductive base, as shown in FIGURE 8A, a conductive base assembly 800 is depicted having a pattern 802 is punched out or etched into the conductive base 801. Pattern 802 reduces the number of punched-out gaps required and increase the spacing between such gaps. Pilot holes 805 act as a guide for the manufacturing and assembly process. As shown in FIGURE 8B, the LEDs 202 are short-circuited without the removal of additional material. In one embodiment, the material from conductive base 801 is removed after the LEDs 202 are mounted.

[0087] *Fourth Embodiment of the Conductive Base*

[0088] As illustrated in FIGURE 9A, a fourth embodiment of the conductive base assembly 900 contains an alternative hole pattern 902 that, in one embodiment, is absent of any pilot holes. Compared to the third embodiment, more gaps are punched out in order to create two conducting portions in the conductive base 901. Thus, as shown in FIGURE 9B, this embodiment has a working circuit where the LEDs 202 connected in series.

[0089] *Fifth and Sixth Embodiments of the Conductive Base*

[0090] FIGURE 10A illustrates a fifth embodiment of conductive base assembly 1000 of the conductive base 1001. Shown is a thin LED light wire with a typical outer diameter of 3mm or less. As shown in FIGURE 10A, (1) the LEDs 202 connected on the conductive base 1001 are placed apart, preferably at a predetermined distance. In a typical application, the LEDs 202 are spaced from 3cm to 1m, depending upon, among other things, at least the power of the LEDs used and whether such LEDs are top or side-emitting. The conductive base 1001 is shown absent of any pilot holes. The punched-out gaps that create a first hole pattern 1014 that are straightened into long thin rectangular shapes. The gaps 1030 under the LEDs 202 are punched out after the LEDs 202 are mounted to conductive base 1001, or, in the alternative, LEDs 202 are mounted over punched-out gaps 1030. However, as shown in FIGURE 10B, the resultant circuit for this embodiment is not useful since all the LEDs 202 are short-circuited. In subsequent procedures, additional material is removed from conductive base 1001 so that LEDs 202 are in series or parallel as desired.

[0091] In the sixth embodiment of the conductive base assembly 1100, conductive base 1101, as shown in FIGURE 11A, contains a hole pattern 1118 which creates a working circuit in the conductive base 1101 with a series connections of LEDs 202 mounted onto the conductive base 1101. This embodiment is useful in creating a thin LED light wire with a typical outside diameter of 3mm or less.

[0092] *LEDs*

[0093] The LEDs 202 may be, but are not limited to, individually-packaged LEDs, chip-on-board (“COB”) LEDs, leaded LEDs, surface mount LEDs, SMD-On-Board LEDs, or LED dies individually die-bonded to the conductive base 301. The PCB for COB LEDs and SMD-On-Board LEDs may be, for example, FR4 PCB, flexible PCB, or metal-core PCB. The LEDs 202 may also be top-emitting LEDs, side-emitting LEDs, or a combination thereof.

[0094] The LEDs 202 are not limited to single colored LEDs. Multiple-colored LEDs may also be used. For example, if Red/Blue/Green LEDs (RGB LEDs) are used to create a pixel, combined with a variable luminance control, the colors at each pixel can combine to form a range of colors.

[0095] *Mounting of LEDs onto the Conductive Base*

[0096] As indicated above, LEDs 202 are mounted onto the conductive base by methods known in the art, including surface mounting, LED chip bonding, spot welding and laser welding.

[0097] In surface mounting, as shown in FIGURES 12A and 12B, the conductive base 1201 is first punched to assume any one of the embodiments discussed above, and then stamped to create an LED mounting area 1210. The LED mounting area 1210 shown is exemplary, and other variations of the LED mounting area 1210 are possible. For example, the LED mounting area 1210 may be stamped into any shape which can hold an LED 202, or not stamped.

[0098] A soldering material 1210 (e.g., liquid solder; solder cream; solder paste; and any other soldering material known in the art) or conductive epoxy is placed either manually or by a programmable assembly system in the LED mounting area 1220, as illustrated in FIGURE 12A. LEDs 202 are then placed either manually or by a programmable pick and place station on top of the soldering material 1210 or a suitable conductive epoxy. The conductive base 1201 with a plurality of LEDs 202 individually mounted on top of the soldering material 1210 may directly go into a programmable reflow chamber where the soldering material 1210 is melted or a curing oven where the

conductive epoxy is cured. As a result, the LEDs 202 are bonded to the conductive base 1201 as shown in FIGURE 12B.

[0099] As illustrated in FIGURE 13, LEDs 202 may be mounted onto the conductive base 1301 by LED chip bonding. The conductive base 1301 is stamped to create a LED mounting area 1330. The LED mounting area 1330 shown in FIGURE 13 is exemplary, and other variations of the LED mounting area 1330, including stamped shapes, like the one shown in FIGURE 12A, which can hold an LED, are envisioned. LEDs 202, preferably an LED chip, are placed either manually or by a programmable LED pick place machine onto the LED mounting area 1330. The LEDs 202 are then wire bonded onto the conductive base 1301 using a wire 1340. It should be noted that wire bonding includes ball bonding, wedge bonding, and the like. Alternatively, LEDs 202 may be mounted onto the conductive base 301 using a conductive glue or a clamp.

[00100] It should be noted that the conductive base in the above embodiments can be twisted in an "S" shape. Then, the twisting is reversed in the opposite direction for another predetermined number of rotations; thereby, making the conductive base form a shape of a "Z". This "S-Z" twisted conductive base is then covered by an encapsulant. With its "S-Z" twisted placement, this embodiment will have increased flexibility, as well as emit light uniformly over 360°.

[00101] In another embodiment, as shown in FIGURE 11C, conductive base (e.g., conductive base 1101) delivering electrical current to the LEDs is wound into spirals. The spiraling process can be carried out by a conventional spiraling machine, where the conductive base is placed on a rotating table and a core 9000 passes through a hole in the center of the table. The pitch of the LED is determined by the ratio of the rotation speed and linear speed of the spiraled assembly. The core 9000 may be in any three-dimensional shape, such as a cylinder, a rectangular prism, a cube, a cone, a triangular prism, and may be made of, but not limited to, polymeric materials such as polyvinyl chloride (PVC), polystyrene, ethylene vinyl acetate (EVA), polymethylmethacrylate (PMMA) or the like, or, in one embodiment, elastomer materials such as silicon rubber. The core 9000 may also be solid. In one embodiment, the conductive base delivering

electrical current to the LEDs is wound into spirals on a solid plastic core and then encapsulated in a transparent elastomer encapsulant.

[00102] *Encapsulant*

[00103] The encapsulant provides protection against environmental elements, such as water and dust, and damage due to loads placed on the integral LED light wire. The encapsulant may be flexible or rigid, and transparent, semi-transparent, opaque, and/or colored. The encapsulant may be made of, but not limited to, polymeric materials such as polyvinyl chloride (PVC), polystyrene, ethylene vinyl acetate (EVA), polymethylmethacrylate (PMMA) or other similar materials or, in one embodiment, elastomer materials such as silicon rubber.

[00104] Fabrication techniques concerning the encapsulant include, without limitation, extrusion, casting, molding, laminating, injection molding, or a combination thereof.

[00105] In addition to its protective properties, the encapsulant assists in the scattering and guiding of light in the LED light wire. As illustrated in FIGURE 14, that part of the light from the LEDs 202 which satisfies the total internal reflection condition will be reflected on the surface of the encapsulant 1403 and transmitted longitudinally along the encapsulant 1403. Light scattering particles 1404 may be included in the encapsulant 1403 to redirect such parts of the light as shown by light path 1406, as well as attenuate or eliminate hot spots of light. The light scattering particles 1404 are of a size chosen for the wavelength of the light emitted from the LEDs. In a typical application, the light scattering particles 1404 have a diameter in the scale of nanometers and they can be added to the polymer either before or during the extrusion process.

[00106] The light scattering particles 1404 may also be a chemical by-product associated with the preparation of the encapsulant 1403. Any material that has a particle size (e.g., a diameter in the scale of nanometers) which permits light to scatter in a forward direction can be a light scattering particle.

[00107] The concentration of the light scattering particles 1404 is varied by adding or removing the particles. For example, the light scattering particles 1404 may be in the form of a dopant added to the starting material(s) before or during the extrusion process. Also, air bubbles or any other internal voids may be used as a light scattering particle 1404. The concentration of the light scattering material 1404 within the encapsulant 1403 is influenced by the distance between LEDs, the brightness of the LEDs, and the uniformity of the light. A higher concentration of light scattering material 1404 may increase the distance between neighboring LEDs 202 within the LED light wire. The brightness of the LED light wire may be increased by employing a high concentration of light scattering material 1404 together within closer spacing of the LEDs 202 and/or using brighter LEDs 202. The smoothness and uniformity of the light within the LED light wire can be improved by increasing the concentration of light scattering material 1404 may increase such smoothness and uniformity.

[00108] As shown in FIGURES 3, 5A and 5B, the sub-assemblies 310, 510 and 750 are substantially at the center of the encapsulant. The sub-assemblies 310, 510 and 750 are not limited to this location within the encapsulant. The sub-assemblies 310, 510 and 750 may be located anywhere within the encapsulant. Additionally, the cross-sectional profile of the encapsulant is not restricted to circular or oval shapes, and may be any shape (*e.g.*, square, rectangular, trapezoidal, star). Also, the cross-sectional profile of the encapsulant may be optimized to provide either a narrow or wide viewing angle (see light paths 1450 and 1460 in FIGURES 14B (dome-shaped profile of encapsulant 222) and 14C (flat-top profile of encapsulant 223), respectively) and/or lensing for light emitted by the LEDs 202. For example, another thin layer of encapsulant may be added outside the original encapsulant to further control the uniformity of the emitted light from the present invention.

[00109] *Surface Texturing and Lensing*

[00110] The surface of the integral LED light wire can be textured and/or lensed for optical effects. The integral single piece LED light wire may be coated (*e.g.*, with a fluorescent material), or include additional layers to control the optical properties (*e.g.*,

the diffusion and consistency of illuminance) of the LED light wire. Additionally, a mask may be applied to the outside of the encapsulant to provide different textures or patterns.

[00111] Different design shapes or patterns may also be created at the surface of the encapsulant by means of hot embossing, stamping, printing and/or cutting techniques to provide special functions such as lensing, focusing, and/or scattering effects. As shown in FIGURES 15A-C, the present invention includes formal or organic shapes or patterns (e.g., dome, waves, ridges) which influences light rays 1500 to collimate (FIGURE 15A), focus (FIGURE 15B), or scatter/diffuse (FIGURE 15C). The surface of the encapsulant may be textured or stamped during or following extrusion to create additional lensing. Additionally, the encapsulant 93, 303 and 503 may be made with multiple layers of different refractive index materials in order to control the degree of diffusion.

[00112] *Applications of Integrally Formed Single Piece LED Light Wire*

[00113] The present invention of the integrally formed single piece LED light wire finds many lighting applications. The following are some examples such as LED light wires with 360° illumination, full color LED light wires, LED light wires with sensor or detectors, and LED light wires with individually controlled LEDs. Also, the LED light wires may be aligned side-by-side or stacked in order to create a lighting panel. It should be noted that these are only some of the possible light wire applications.

[00114] The three copper wires 161, 162, 163 delivering electrical power to the LEDs 202 shown in FIGURE 16B forming the conductive base may be wound into spirals (see FIGURE 11C). The LEDs are connected to the conductors by soldering, ultrasonic welding or resistance welding. Each neighboring LED can be orientated at the same angle or be orientated at different angles. For example, one LED is facing the front, the next LED is facing the top, the third LED is facing the back, and the fourth one is facing the bottom etc. Thus, the integrally formed single piece LED light wire can illuminate the whole surrounding in 360°.

[00115] An embodiment of the integrally formed single piece LED light wire is shown in FIGURES 16B and 16C. As shown, there are two continuous conductors corresponding to conductive bus elements 161 and 163. Zero ohm jumpers or resistors 10 couple conductor segments 162 to conductive bus elements 161 and 163 to provide power to LED elements 202. As shown in FIGURE 16B, the LED light wire includes a support substrate 90. In a preferred embodiment, the support substrate is flexible. In another embodiment, the LED light wire with flexible support substrate is wound about a core 9000 (see, for example, FIGURE 11C), and then is encapsulated in an encapsulant.

[00116] The integrally formed single piece LED light wire is not limited to single color. For full color application, the single color LED is replaced by multiple LEDs or an LED group consisting of four sub-LEDs in four different colors: red, blue, green, and white as shown in FIGURE 20. The intensity of each LED group (one pixel) can be controlled by adjusting the voltage applied across each sub-LED. The intensity of each LED is controlled by a circuit such as the one shown in FIGURE 20.

[00117] In FIGURE 20, L1, L2, and L3 are the three signal wires for supplying electric powers to the four LEDs in each pixel. The color intensity of each sub-LED is controlled by a μ Controller 6000 with the timing chart given in FIGURE 21.

[00118] As shown in FIGURE 21, because the line voltage L2 is higher than the line voltage L1 over the first segment of time, the red LED (R) is turned on, whereas, during the same time interval, all the other LEDs are reverse biased and hence they are turned off. Similarly, in the second time interval, L2 is higher than L3 thus turning on the green LED (G) and turning off all the other LEDs. The turning on/off of other LEDs in subsequent time segments follows the same reasoning.

[00119] New colors such as cold white and orange apart from the four basic ones can be obtained by mixing the appropriate basic colors over a fraction of a unit switching time. This can be achieved by programming a microprocessor built into the circuit. FIGURES 22A and FIGURE 22B show the timing diagrams of color rendering for cold

white and orange respectively. It should be noted that the entire color spectrum can be represented by varying the timing of signals L1, L2, and L3.

[00120] In one embodiment of the invention, each pixel of LEDs can be controlled independently using a microprocessor circuit into the light wire as shown in FIGURE 23. Each LED module 2100 is assigned a unique address. When this address is triggered, that LED module is lit up. It will be noted that each pixel is an LED module consists of a micro-controller and three (RGB) or four (RGBW) LEDs. The LED modules are serially connected with a signal wire based on daisy chain or star bus configuration. Alternatively, the LED modules 2100 are arranged in parallel.

[00121] There are two ways to assign an address for each LED module. In a first approach, a unique address for each pixel is assigned during the manufacturing process. In a second approach, each pixel is assigned an address dynamically with its own unique address and each pixel being characterized by its own "address" periodically with trigger signal. Alternatively, the address is assigned dynamically when powered on. The dynamic addressing has the advantage of easy installation, as the integrally formed single piece LED light wire can be cut to any length. In one embodiment, the light wire can be cut into any desired length while it is powered on and functioning.

[00122] FIGURES 17A-17C depict an embodiment of the LED light wire using a series and parallel connection. This embodiment allows the LEDs to be turned through 90° (positioned transversely instead of longitudinally) and mounted at a much closer pitch.

[00123] As shown in FIGURES 18 thru 19B and 24, the integrally formed single piece LED light wire may have a plurality of conductors (e.g., conductive bus elements and conductive segments) which are coupled by zero ohm jumpers or resistors, LEDs, sensors, detectors and/or microprocessors, and are mounted on a support substrate. The functionality of the LED light wire increases with each additional conductor. For example, a sensor or detector which monitors environment conditions (such as humidity, temperature, and brightness) may be integrated in the LED light wire, and

connected in such a manner that it may influence the lighting characteristics of the LED light wire. FIGURE 18 shows an embodiment of the integrally formed single piece LED light wire with sensors or detectors. As shown, there are four continuous conductors corresponding to conductive bus elements 30, 32, 33 and 34. Zero ohm jumpers or resistors 10 couple conductive segments 31 to conductive bus elements 30 and 32. Conductor bus element 32 acts as a common ground. Conductive bus element 30 provides power to the LEDs 202, while conductive bus element 34 provides power to the sensor/detector 100. Conductive bus element 33 may direct the signal from the sensor/detector 100 to a power source which supplies power to the LEDs 202; thereby, allowing the sensor/detector 100 to influence the lighting characteristics (e.g., intensity, color, pattern, on/off) of the LEDs 202.

[00124] FIGURES 19A and 19B show a full color integrally formed single piece LED light wire having three continuous conductors corresponding to conductive bus elements L1, L2 and L3 which supply power to the LEDs 202, and conductor segments S1 and S2 connecting the LEDs 202 to conductive bus elements L1, L2 and/or L3. In FIGURE 19B, the LEDs 202 are SMD-On-Board LEDs.

[00125] In another embodiment, each pixel of LEDs (or LED module) may be controlled independently. FIGURE 24 shows the configuration of an individually controllable LED light wire using seven conductors and LED modules 2120. Here, conductive bus element 80 acts as a power ground, while conductive bus element 81 acts as a voltage in. Each LED module 2120 includes a microprocessor, at least one LED, power input and output connections, control signal input and output connections, and data input and output connections. In FIGURE 24, the LED modules 2120 include VCC pins, VDD pins, enable pins, clock pins and data pins. The control signal and data input connections of each LED module are coupled to the control signal and data input connections of an adjacent LED module. An optocoupler may be used to insulate the control signal line between each LED module. The LED modules 2120 may be connected in series (for example, as shown in FIGURE 24) or in parallel (for example, the power input connections of each LED module 2120 is coupled to the first conductive

bus element 81 and the power output connection of each LED module 2120 is coupled to the second conductive bus element 80).

[00126] A plurality of integrally formed single piece LED light wires (such as LED light wire 12, 13, 14) may be aligned side-by-side to form a lighting panel 3000 as shown in FIGURES 25A-25C. Each LED light wire may contain an interlocking alignment system comprising an alignment key 60, 62 and an alignment keyhole 61, both of which are pre-formed in the encapsulant of the LED light wire, wherein the alignment key 60, 62 and the alignment keyhole 61 are located at opposite sides of the LED light wire. The alignment key 60, 62 and the alignment keyhole 61, 63 may continuously extend or intermittently extend longitudinally along the length of the LED light wire. The alignment keyhole 61, 63 may be in the form of a notch, a groove, a recess, a slot, or an aperture, and the alignment key 60, 62 may be in a form (including, but without limitation, a rail or a peg) which permits a friction fit (preferably, a snug fit) to the alignment keyhole 61, 63. The alignment key 60, 62 may have a width approximately equal to or slightly larger than the width of the alignment keyhole 61, 63, such that the alignment key 60, 62 may fit therein in a friction fit, as shown in FIGURES 25B and 25C. As an example, the alignment keyhole 61, 63 may be a groove being adapted to friction fit with a rail-shaped alignment key 60, 62, both groove-shaped alignment keyhole 61, 63 and rail-shaped alignment 60 continuously extending longitudinally along the length of the LED light wire.

[00127] Although specific embodiments have been illustrated and described herein, it will be appreciated by those of ordinary skill in the art that a variety of alternate and/or equivalent implementations may be substituted for the specific embodiments shown and described without departing from the scope of the present invention. This application is intended to cover any adaptations or variations of the specific embodiments discussed herein. Therefore, it is intended that this invention be limited only by the claims and the equivalents thereof.

WHAT IS CLAIMED IS:

1. An integrally formed single piece LED light wire, comprising:
 - a support substrate;
 - a conductive base formed on the support substrate, the conductive base comprising a first, second, third and fourth conductive bus elements;
 - at least one conductor segment arranged between the first and second conductive bus elements, the at least one conductor segment comprising at least one LED; and
 - at least one sensor coupled to the third and fourth conductive bus elements, the third conductive bus element is adapted to transmit signals from the at least one sensor, and the fourth conductive bus is adapted to provide power to the at least one sensor.
2. The integrally formed single piece LED light wire of claim 1, wherein the second conductive bus element is a ground and the at least one sensor is additionally coupled to the second conductive bus element.
3. The integrally formed single piece LED light wire of claim 1 or 2, further comprising an encapsulant completely encapsulating the support substrate, the conductive base, the at least one conductor segment and the at least one sensor.
4. The integrally formed single piece LED light wire of claim 3, wherein the encapsulant further comprises light scattering particles.
5. The integrally formed single piece LED light wire of one of claims 1 to 4, further comprising a plurality of conductor segments, wherein the plurality of conductor segments comprising a plurality of LEDs connected in series.

6. The integrally formed single piece LED light wire of claim 1, further comprising a plurality of conductor segments, wherein the plurality of conductor segments comprises a plurality of LEDs connected in series and parallel.

7. The integrally formed single piece LED light wire of claim 1, wherein the first, second, third and fourth conductive bus elements and the at least one conductor segment is made of braided wire.

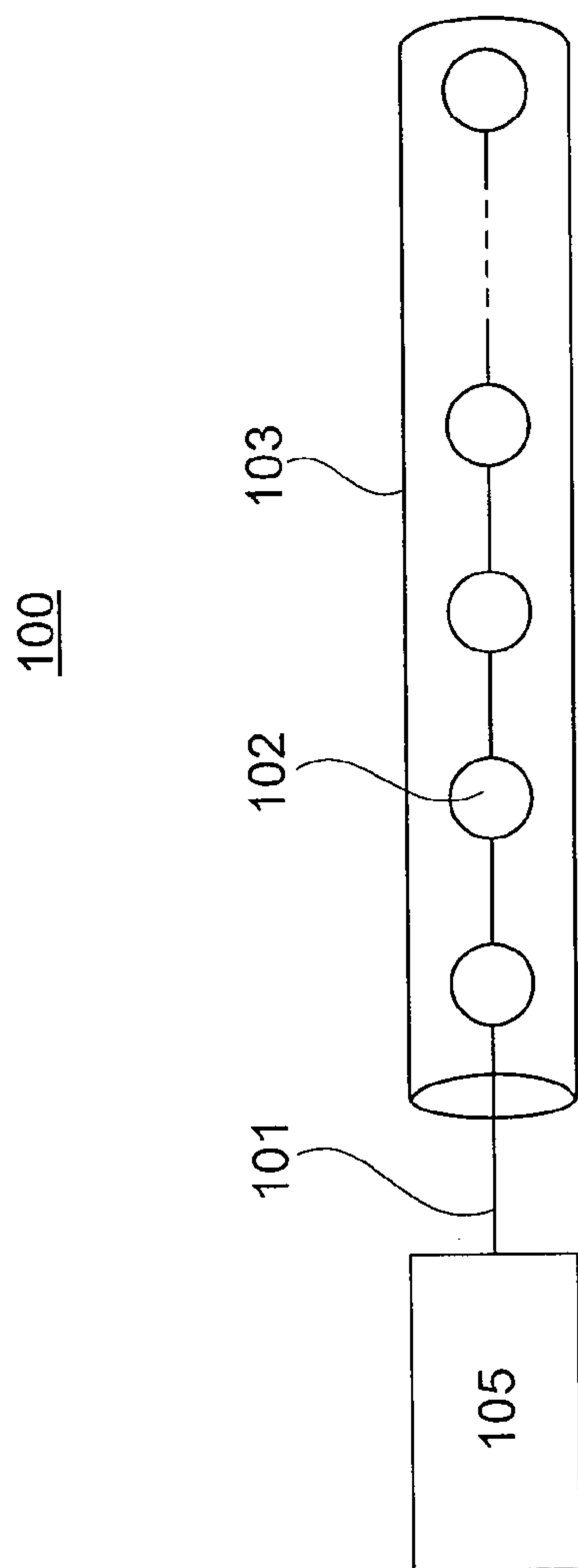

Fig. 1

PRIOR ART

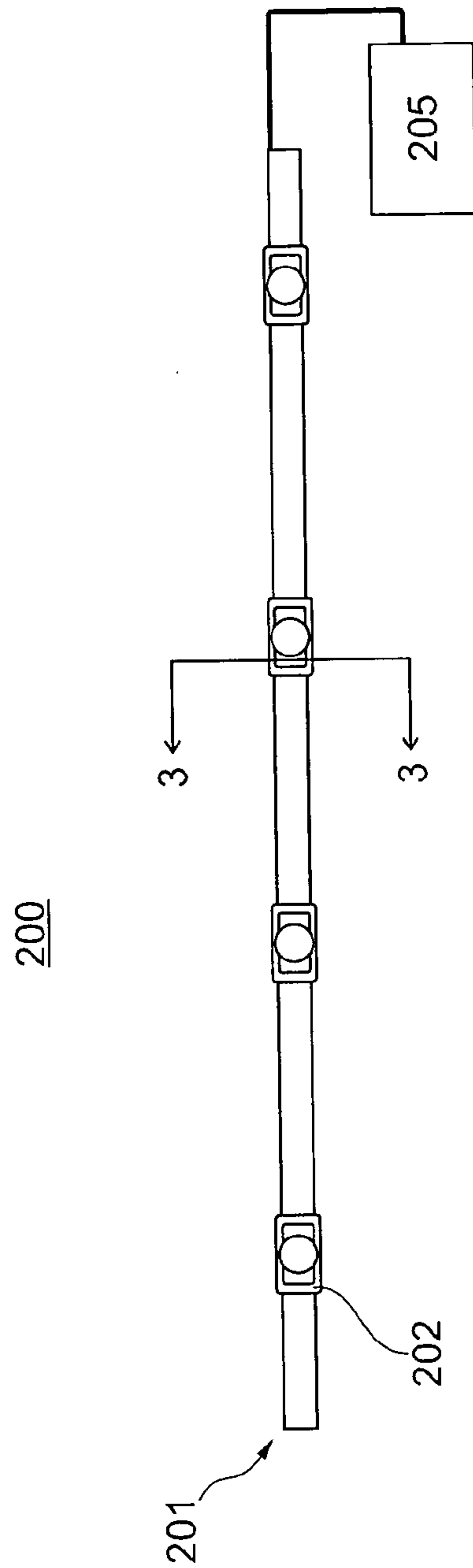

Fig. 2

3/23

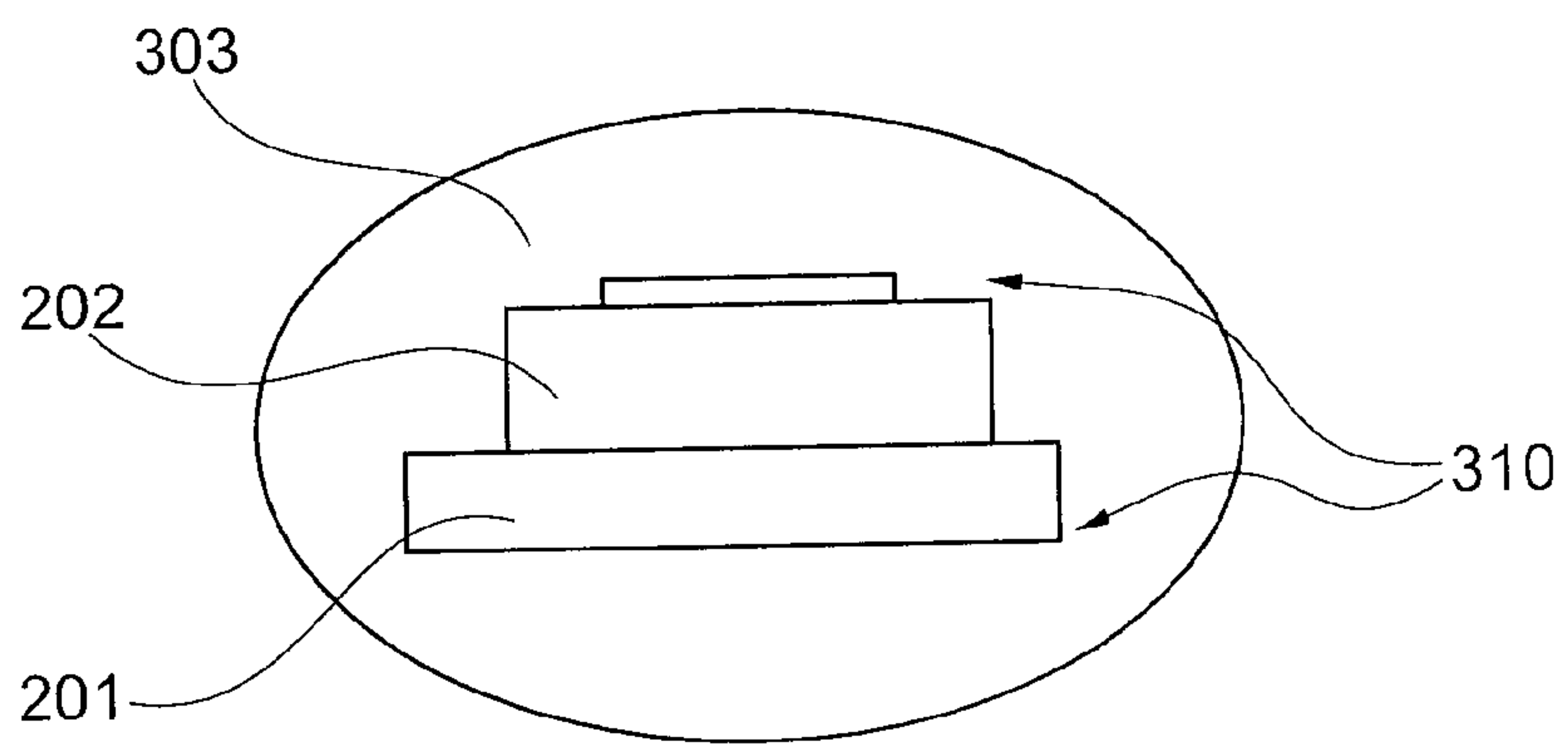

Fig. 3

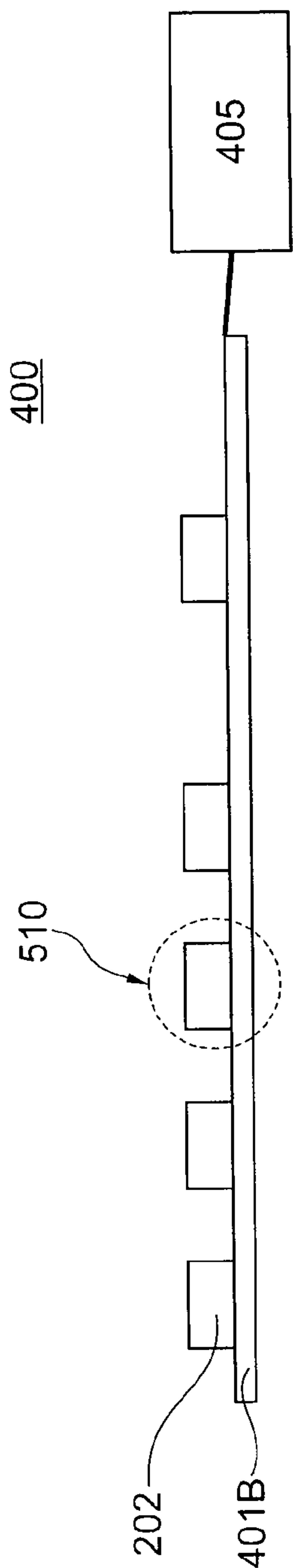

Fig. 4A

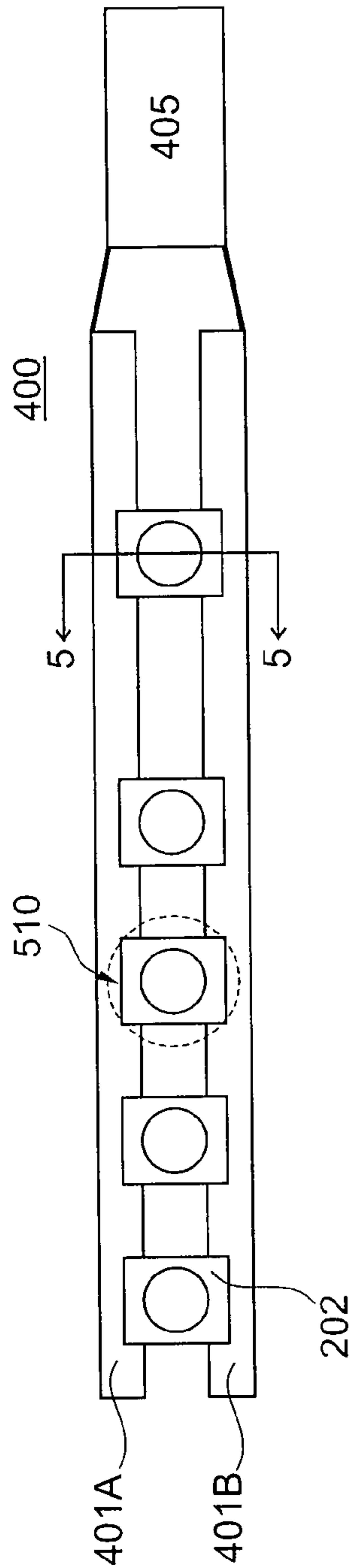

Fig. 4B

5/23

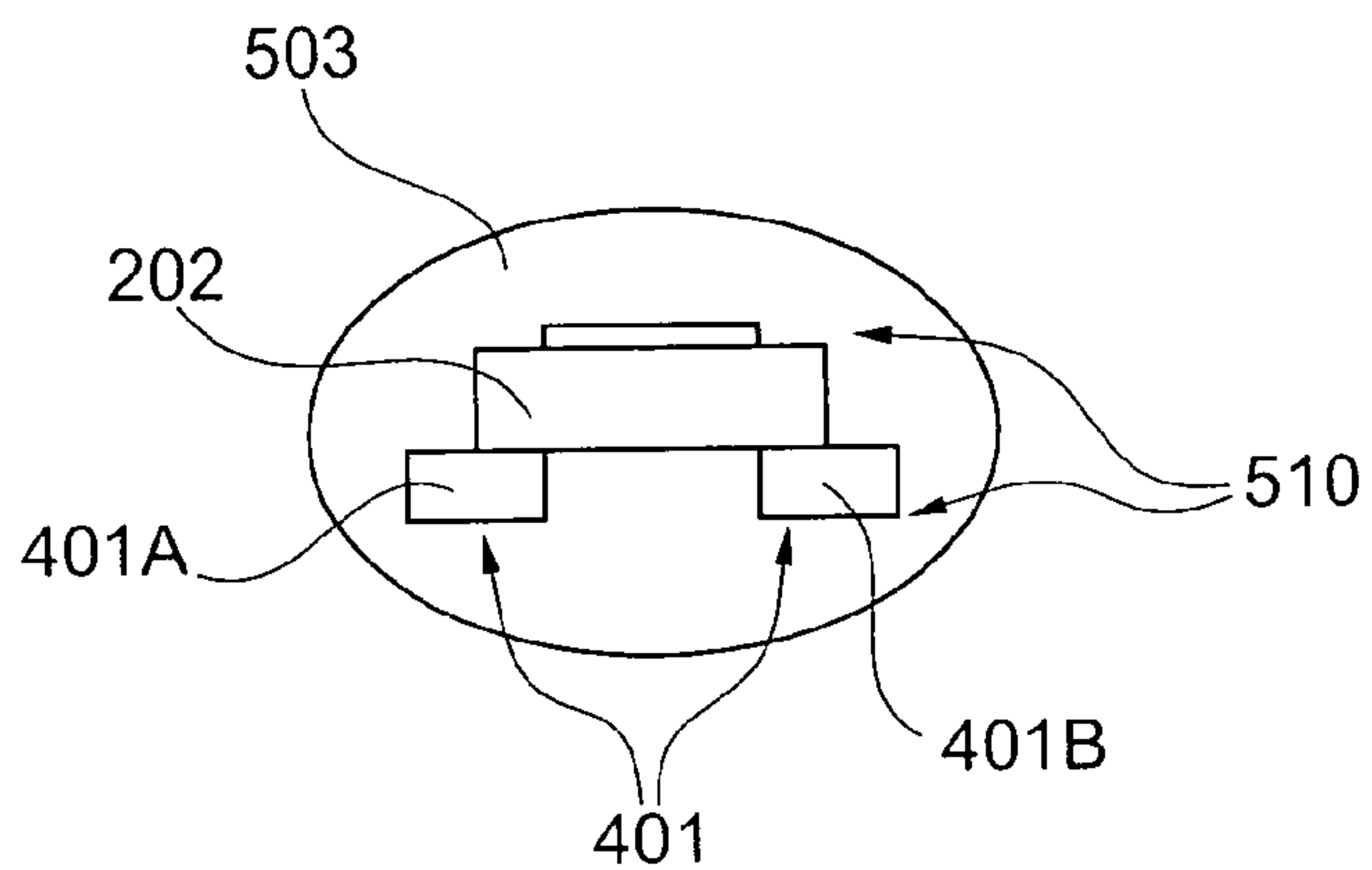

Fig. 5A

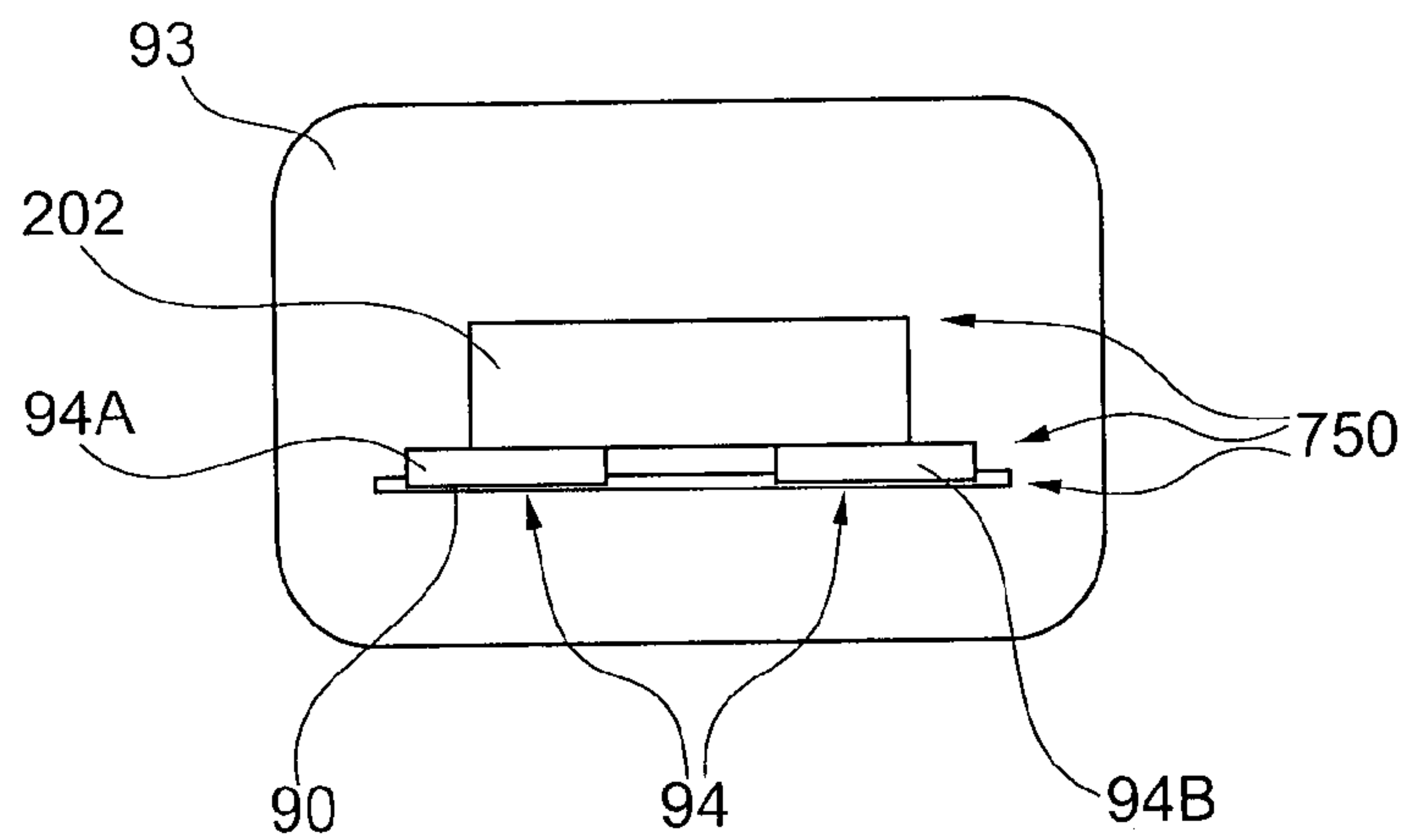

Fig. 5B

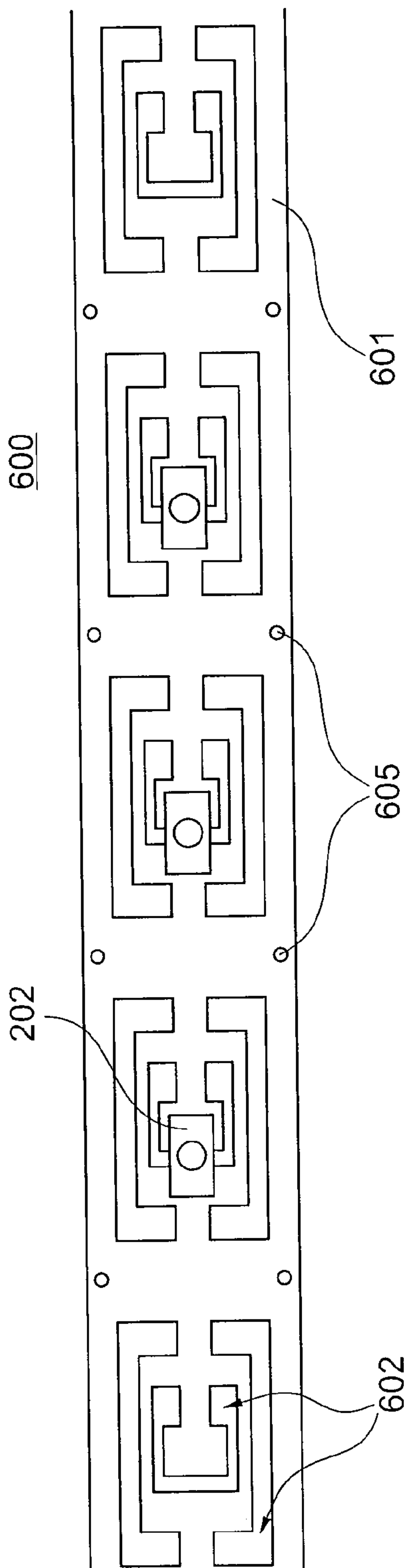

Fig. 6A

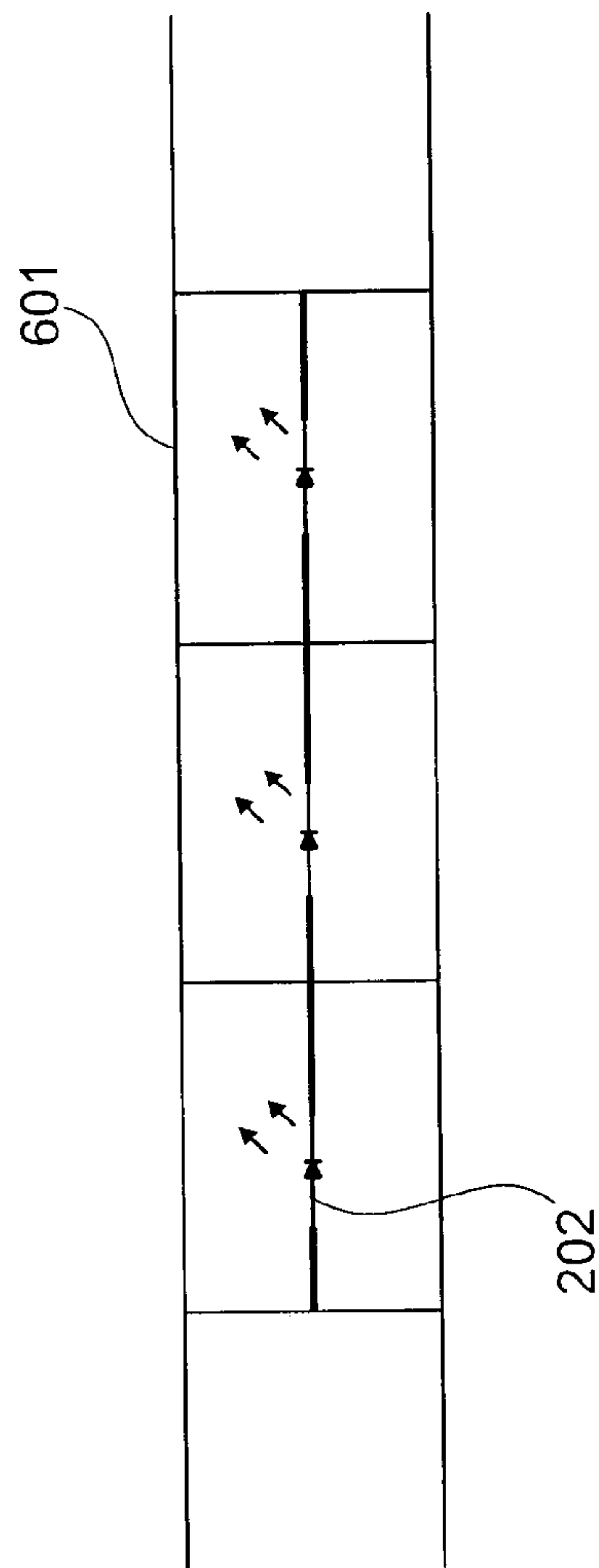

Fig. 6B

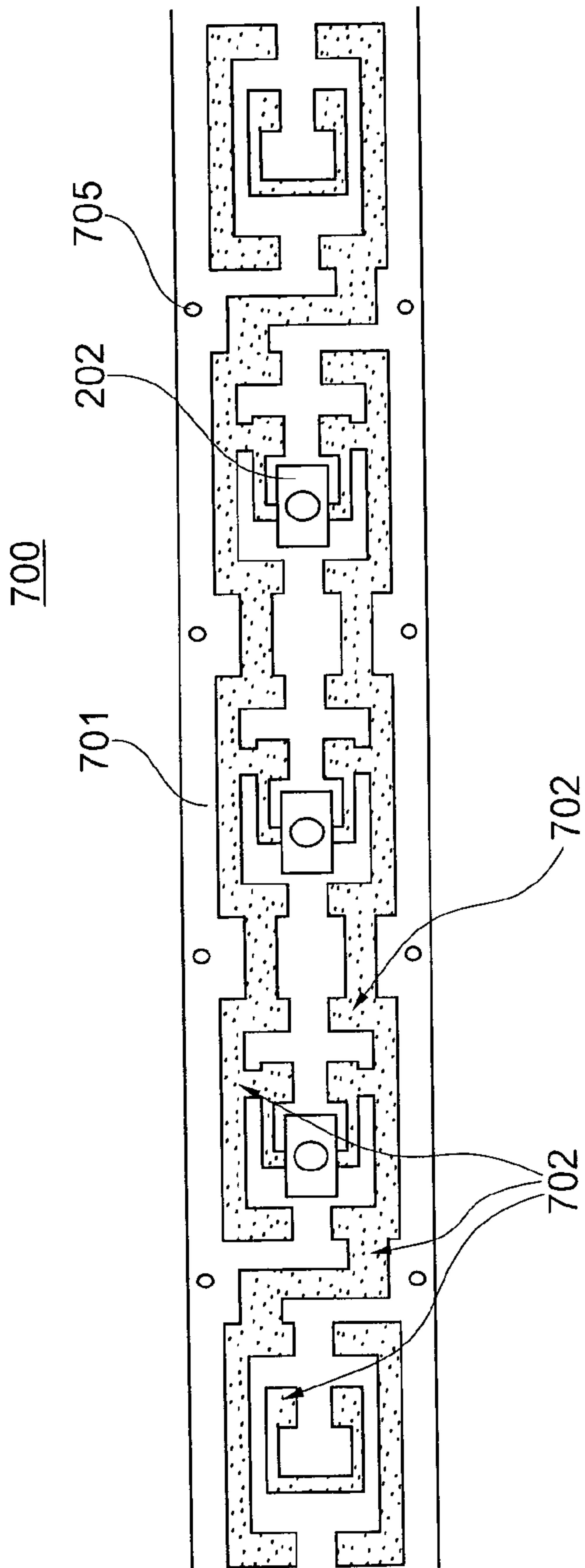

Fig. 7A

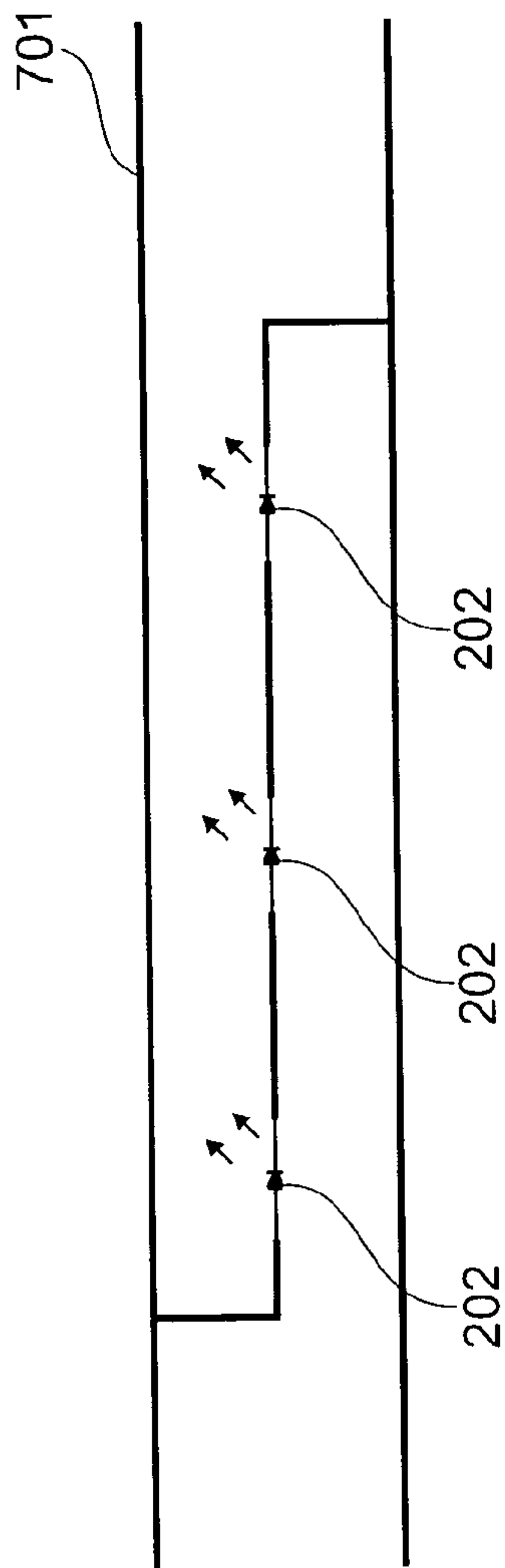

Fig. 7B

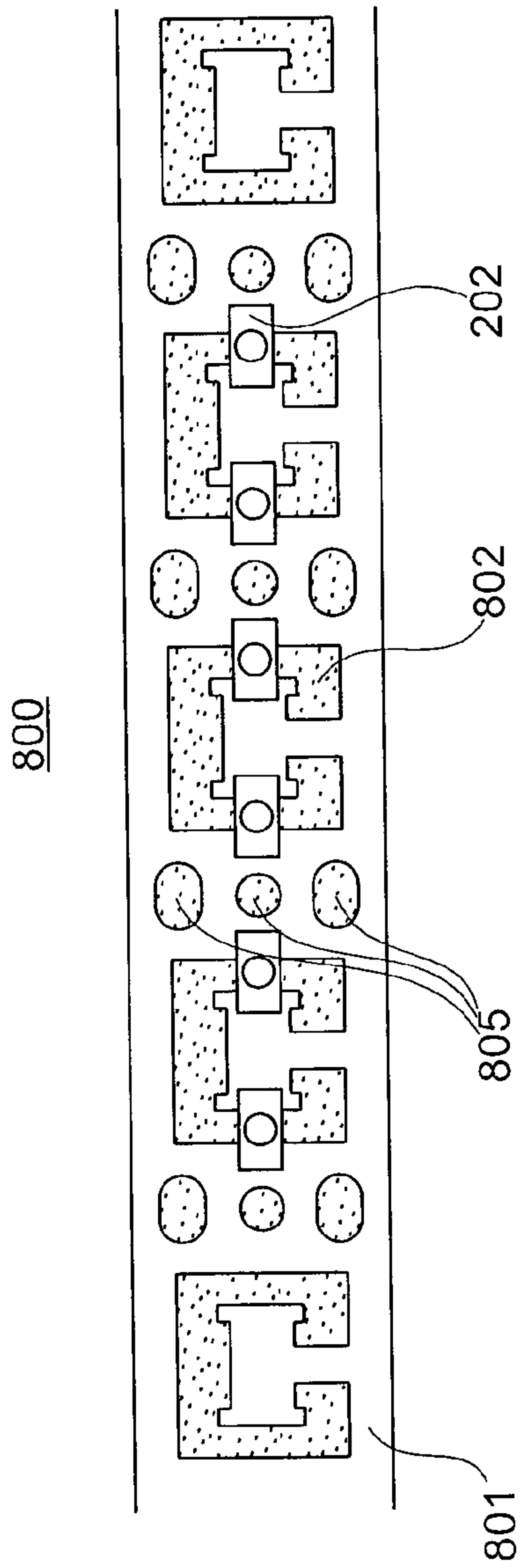

Fig. 8A

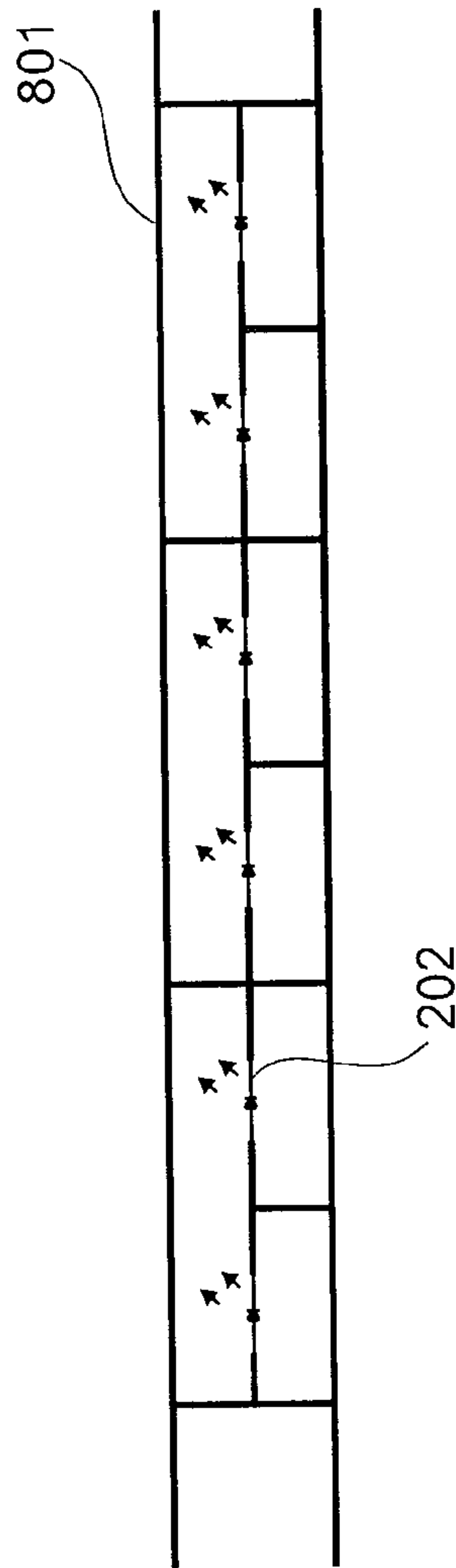

Fig. 8B

9/23

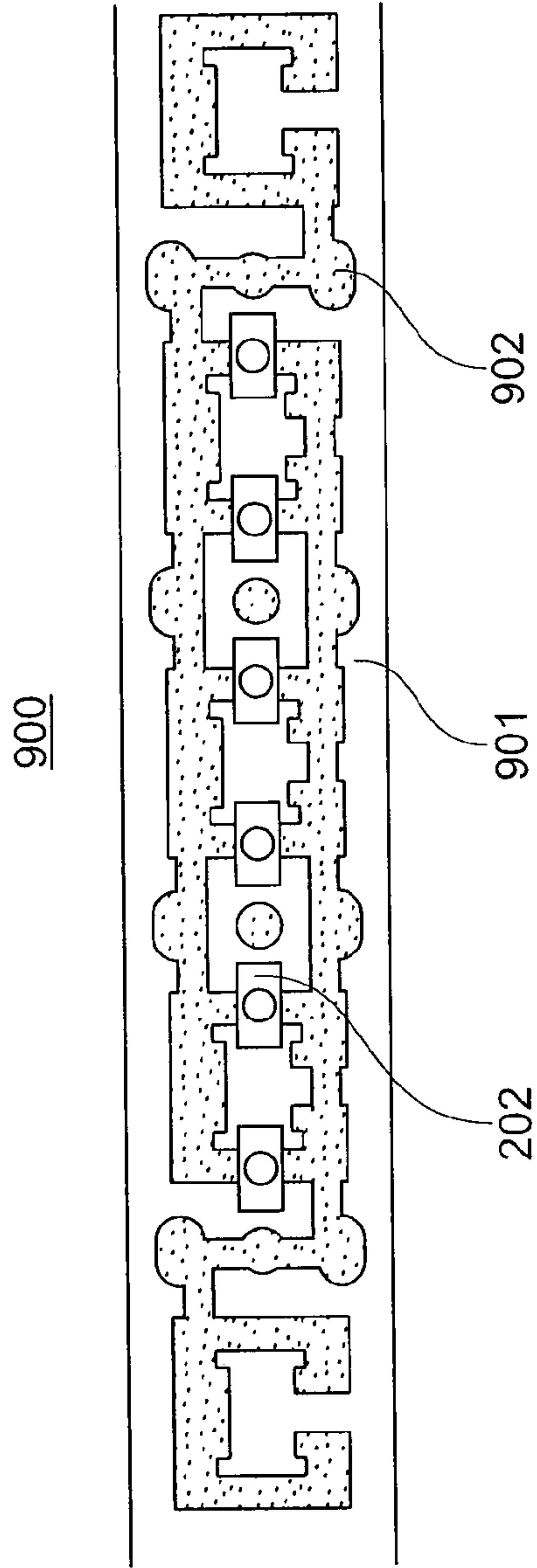

Fig. 9A

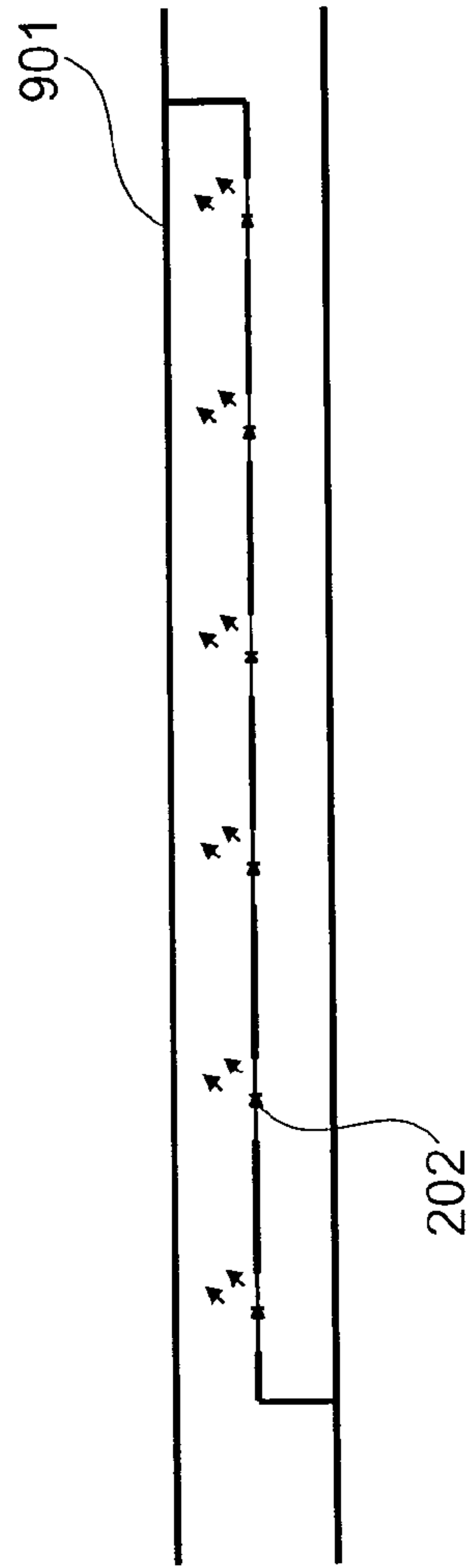

Fig. 9B

10/23

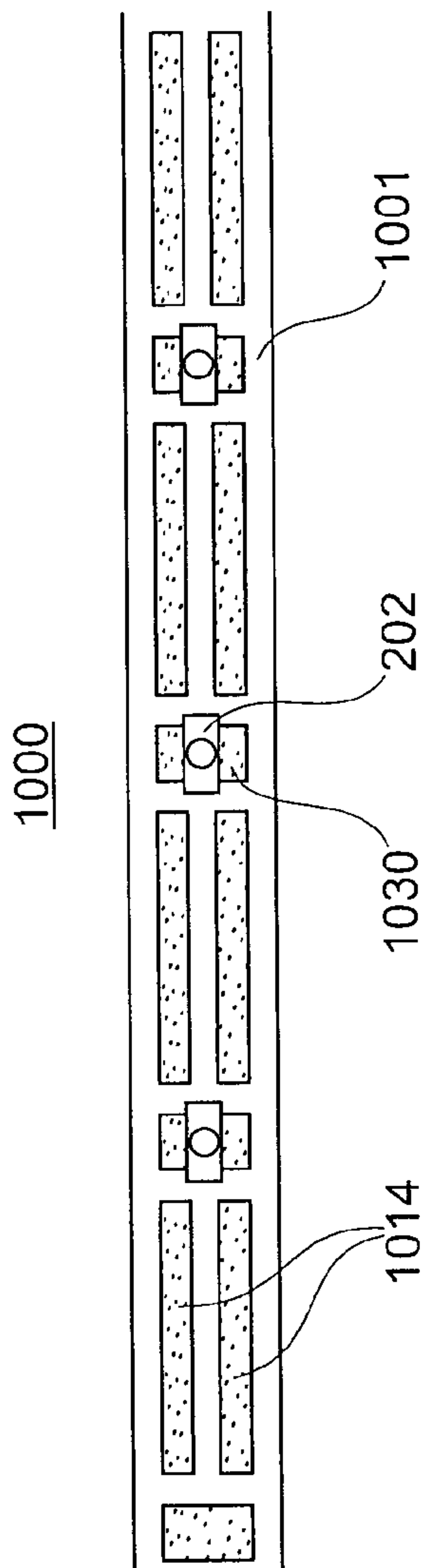

Fig. 10A

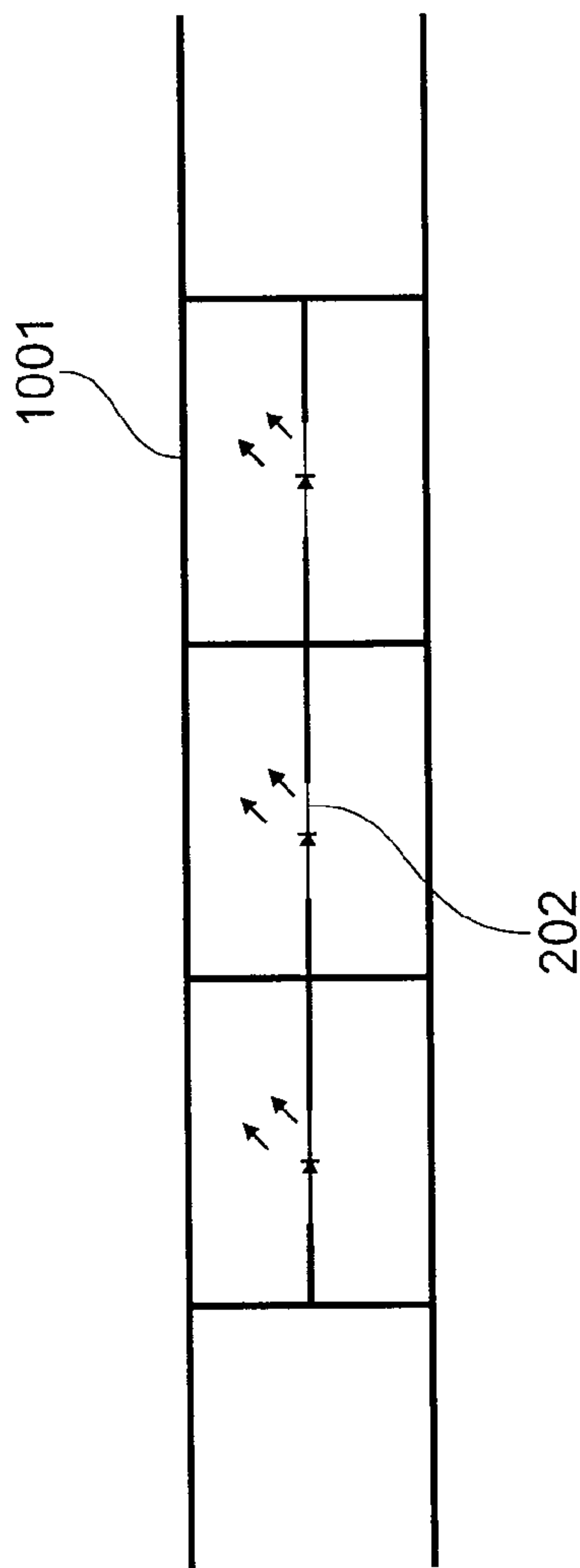

Fig. 10B

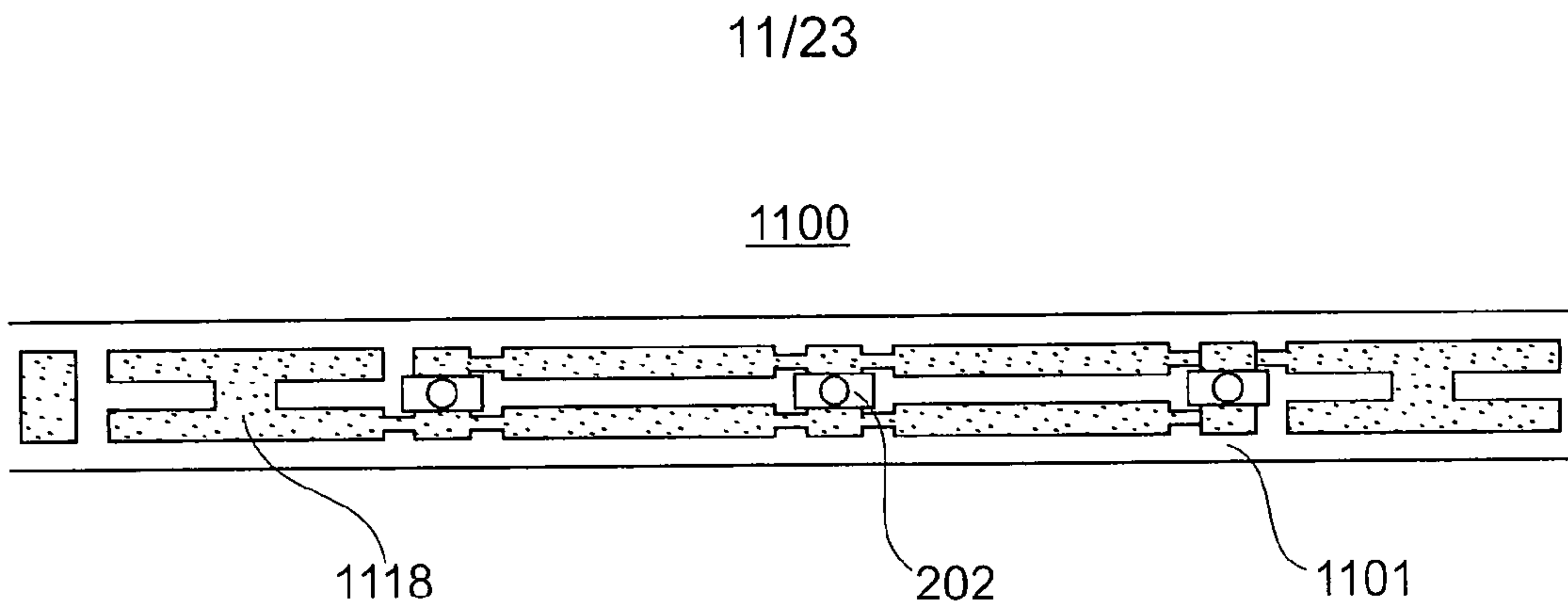

Fig. 11A

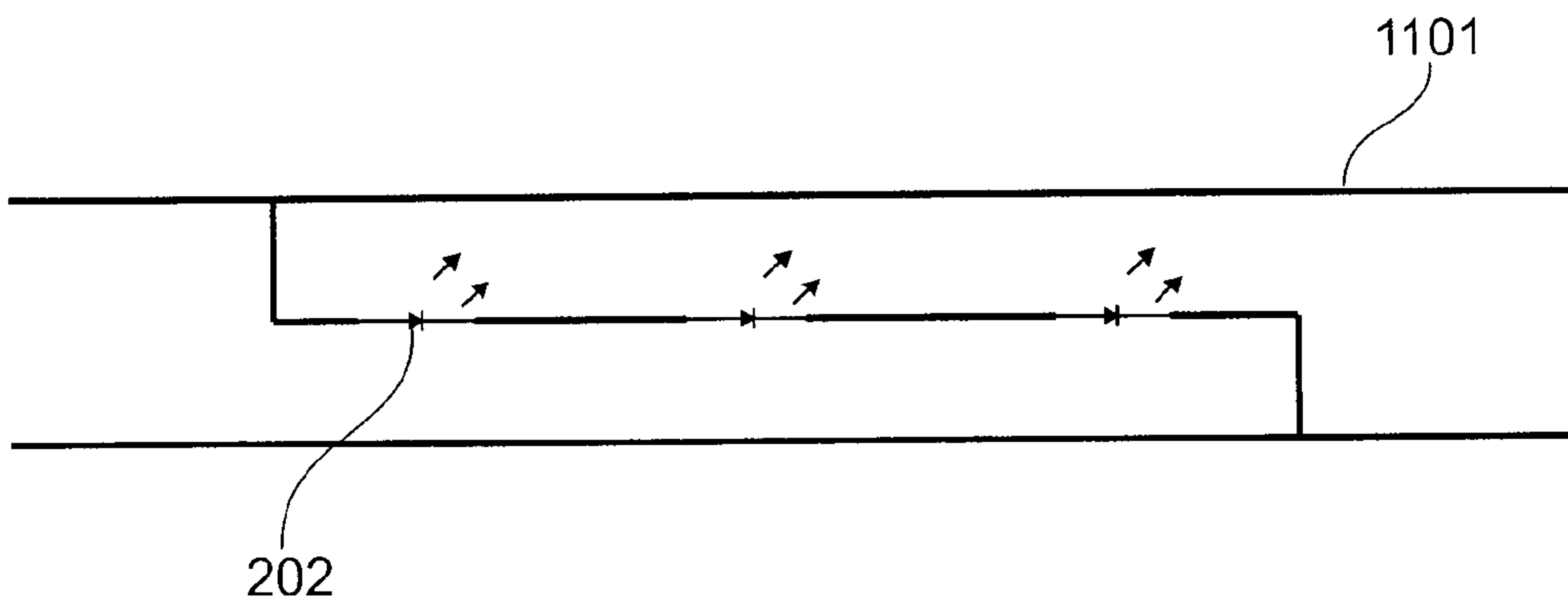

Fig. 11B

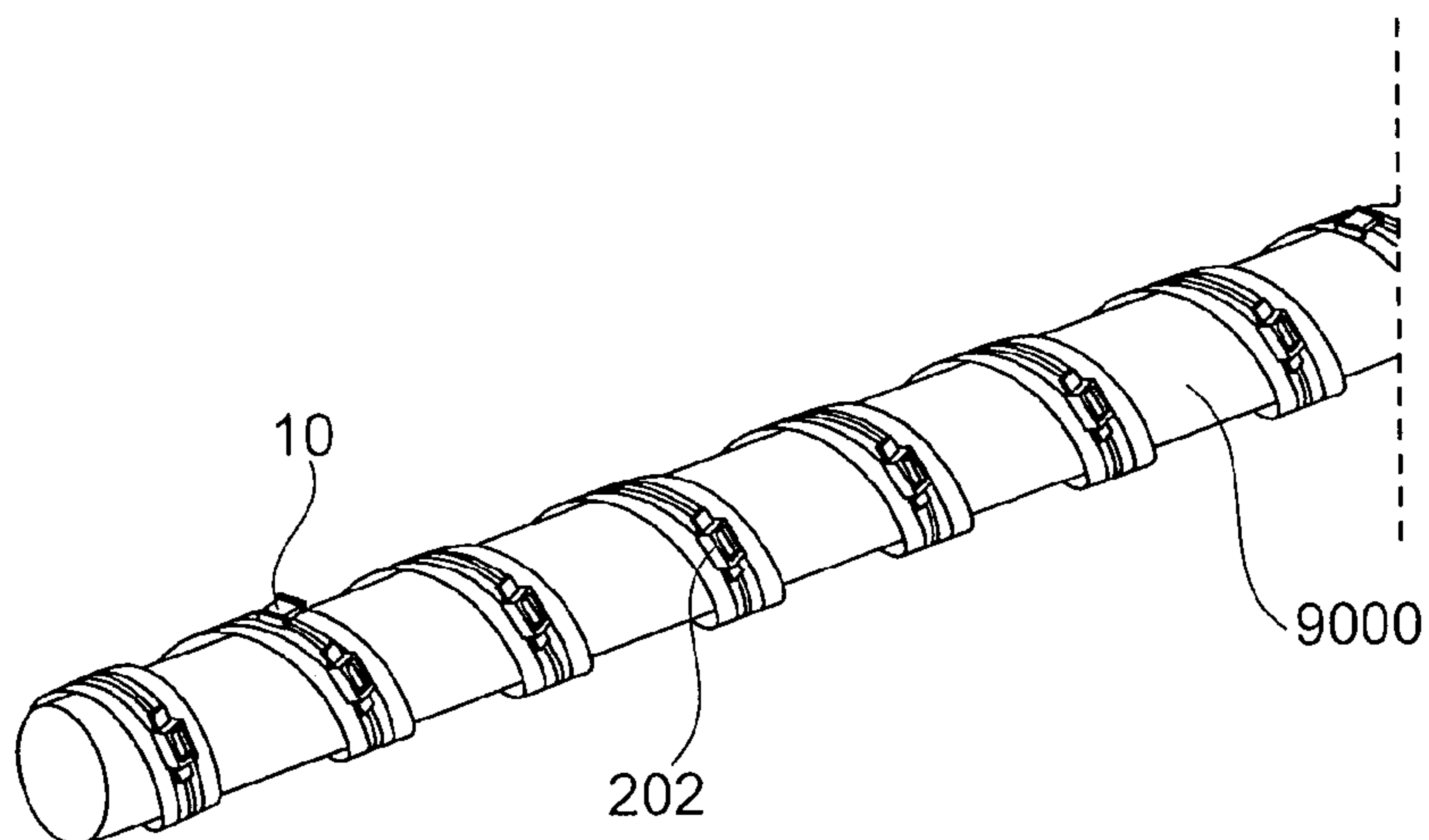

Fig. 11C

12/23

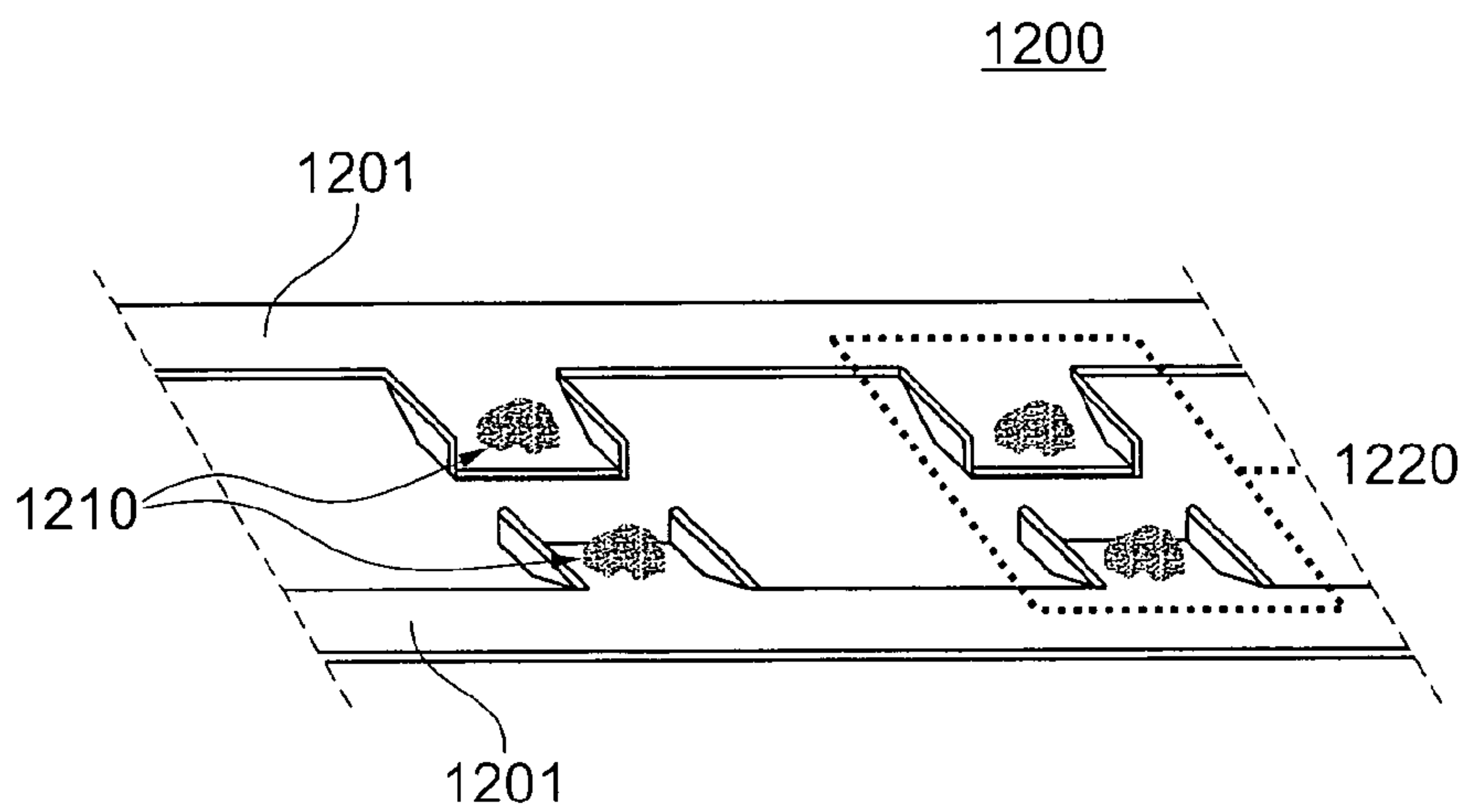

Fig. 12A

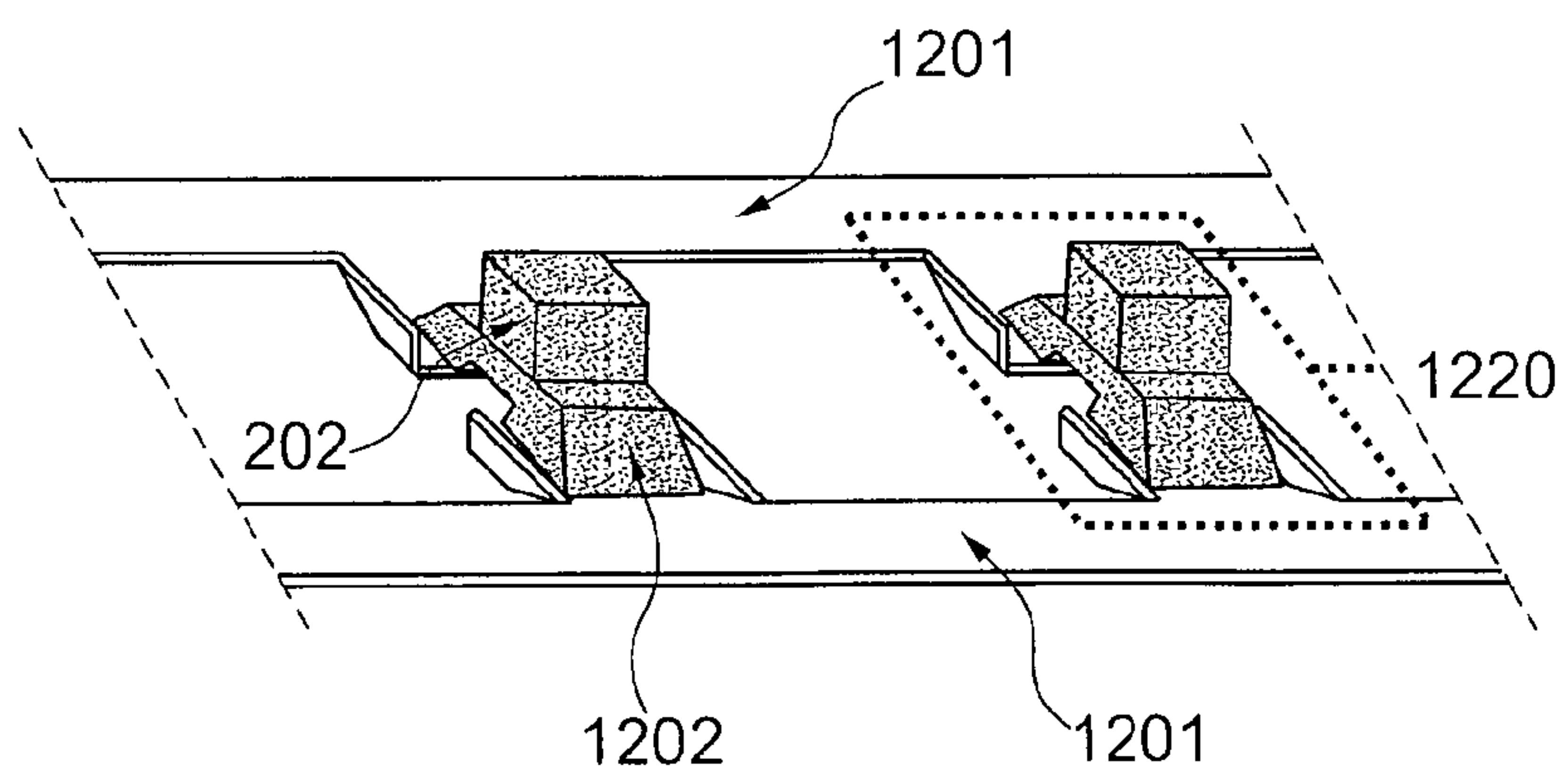

Fig. 12B

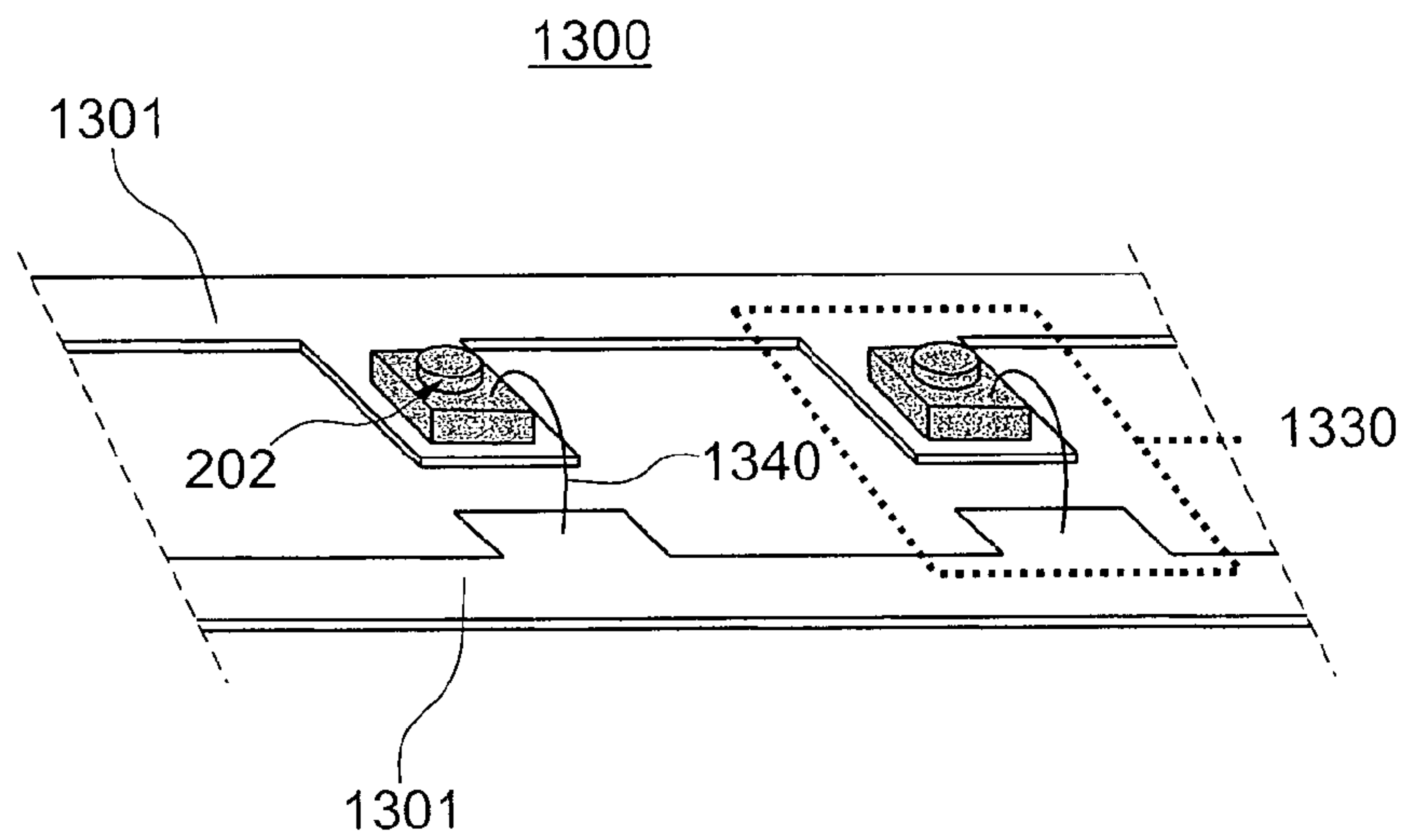

Fig. 13

14/23

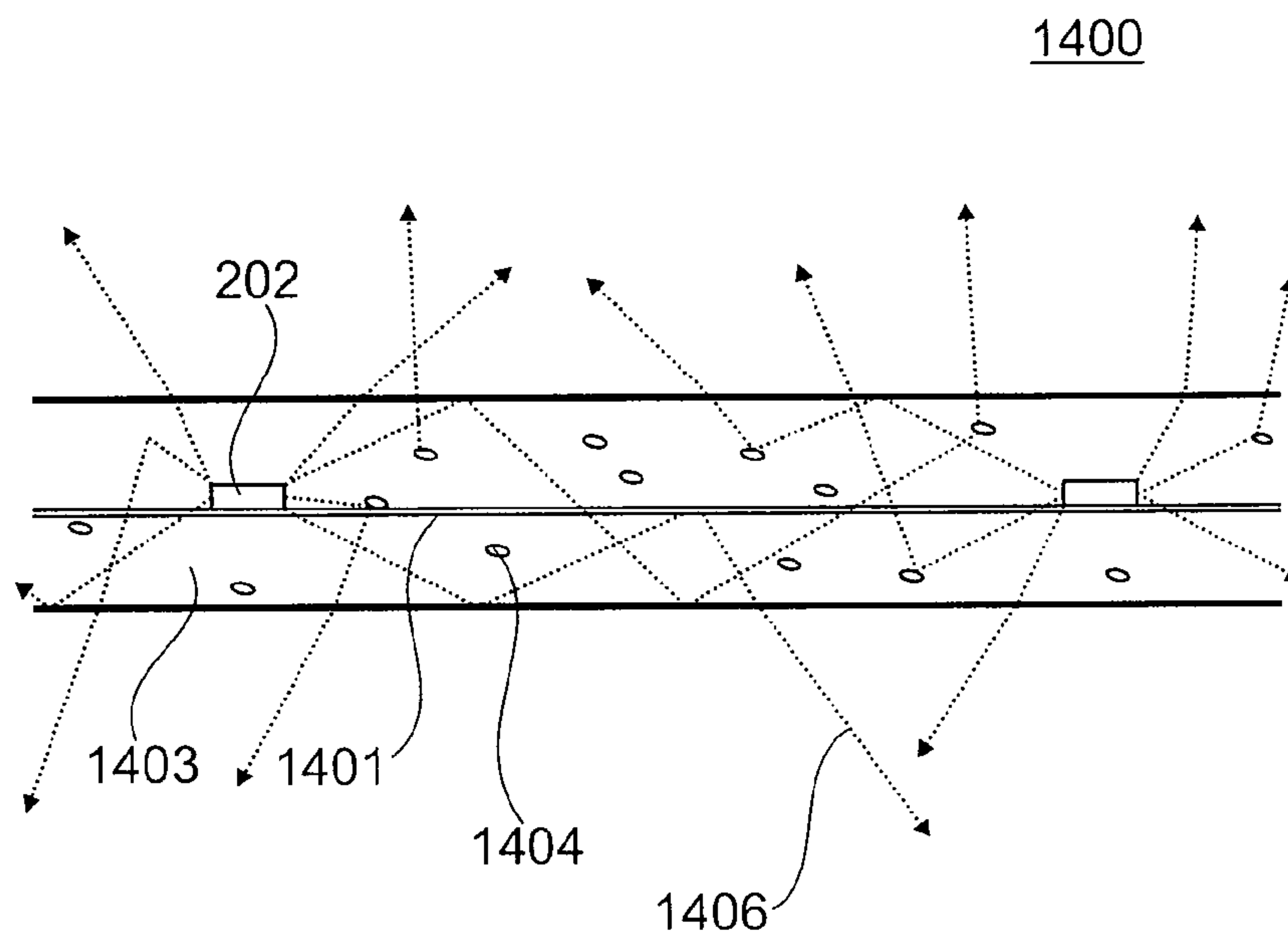

Fig. 14A

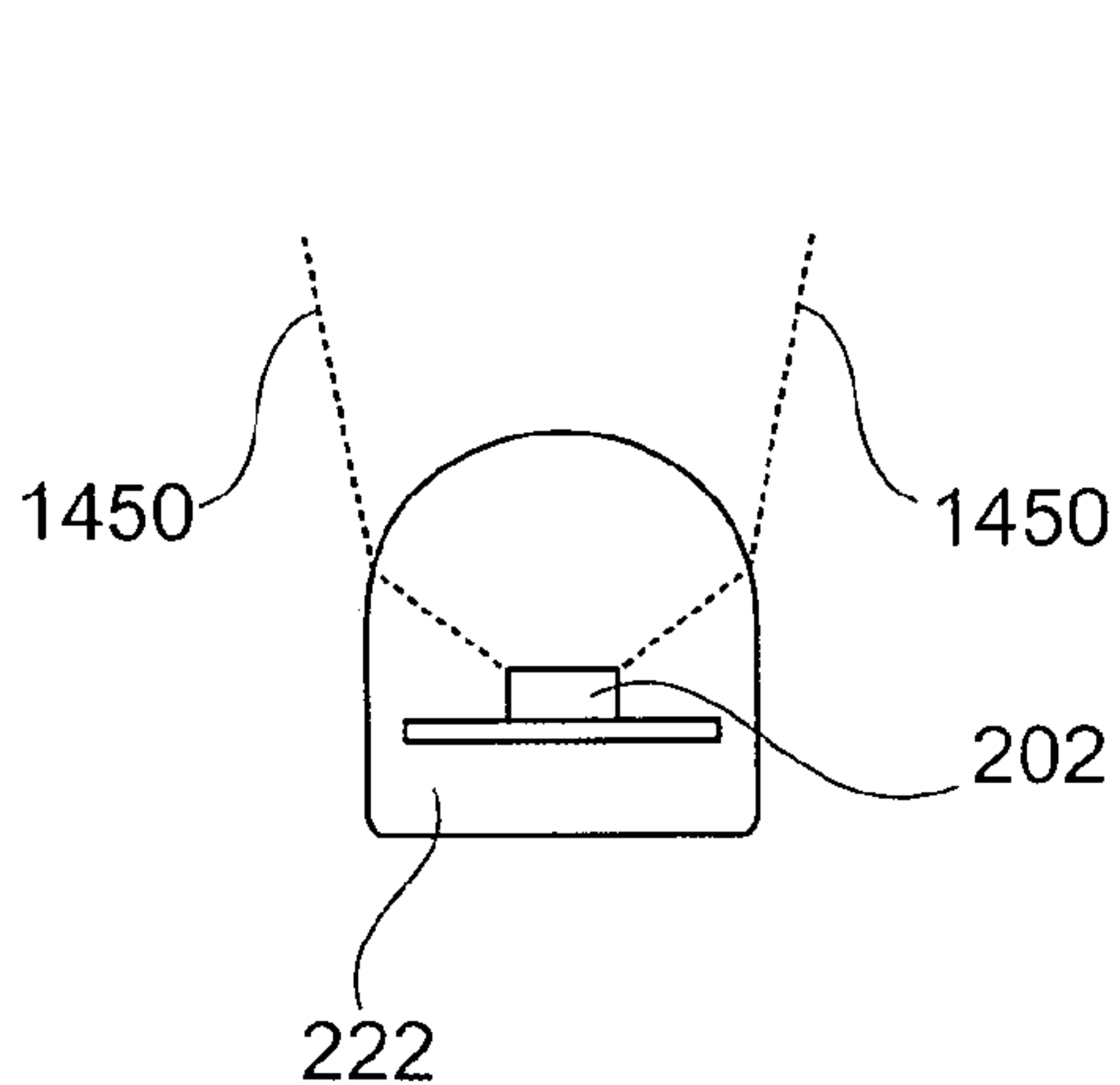

Fig. 14B

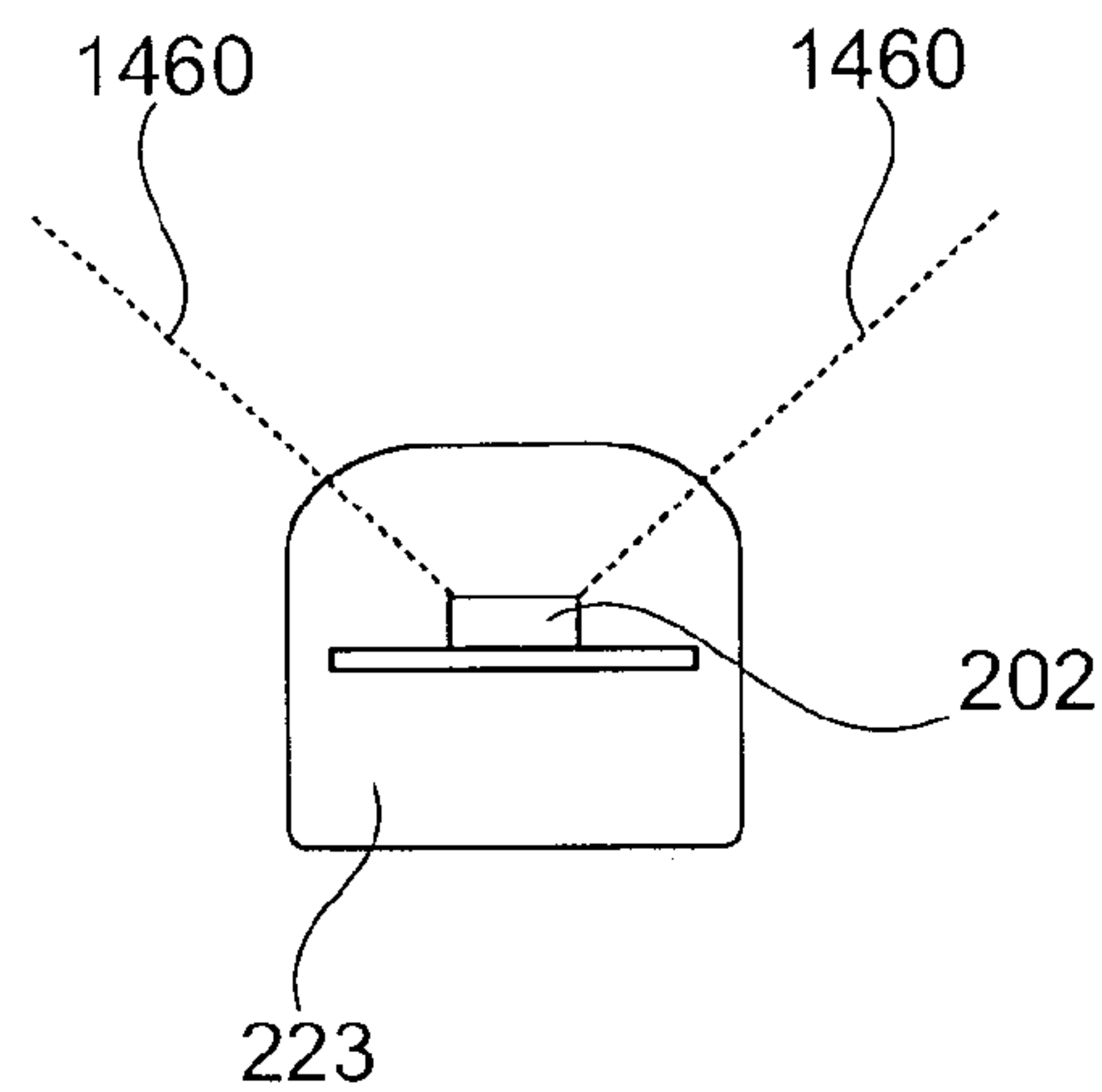

Fig. 14C

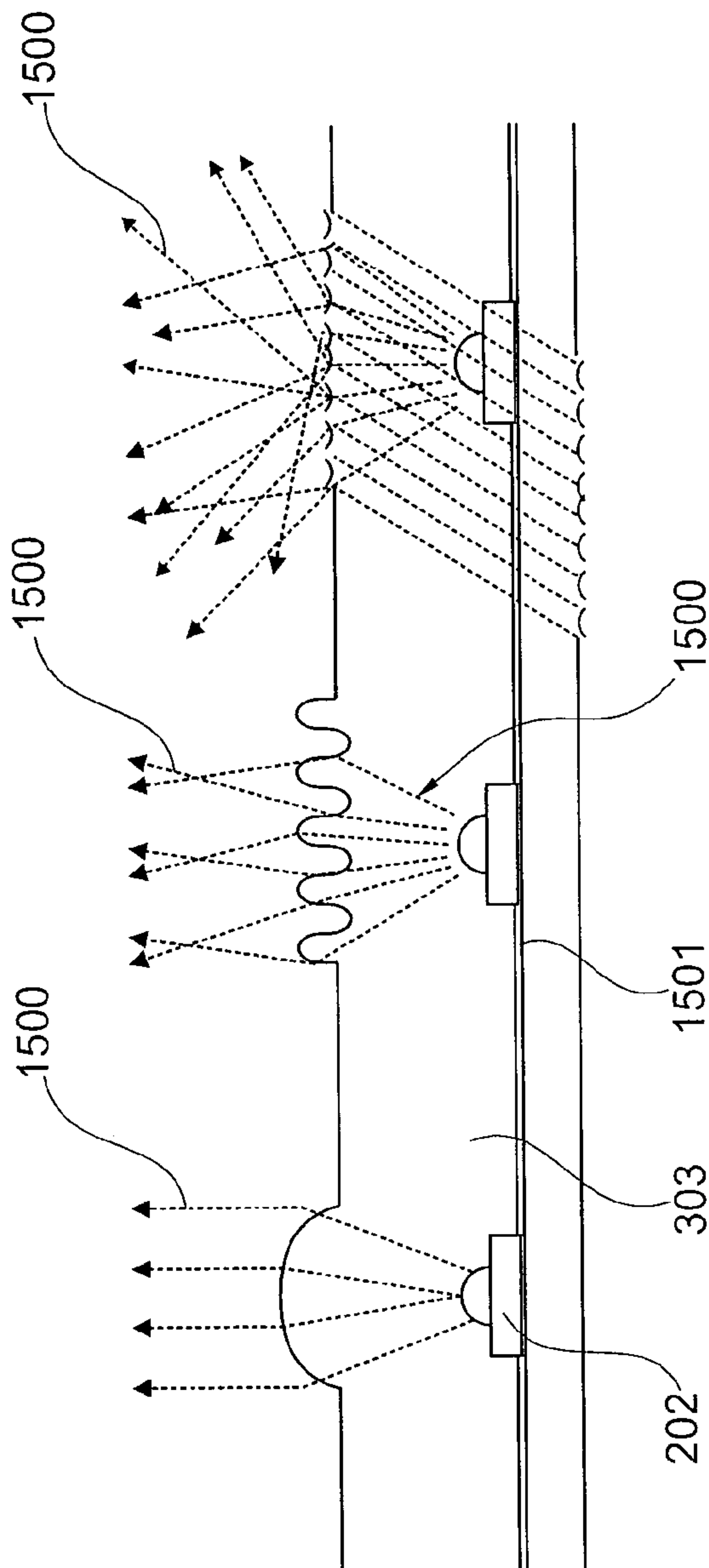

Fig. 15A Fig. 15B Fig. 15C

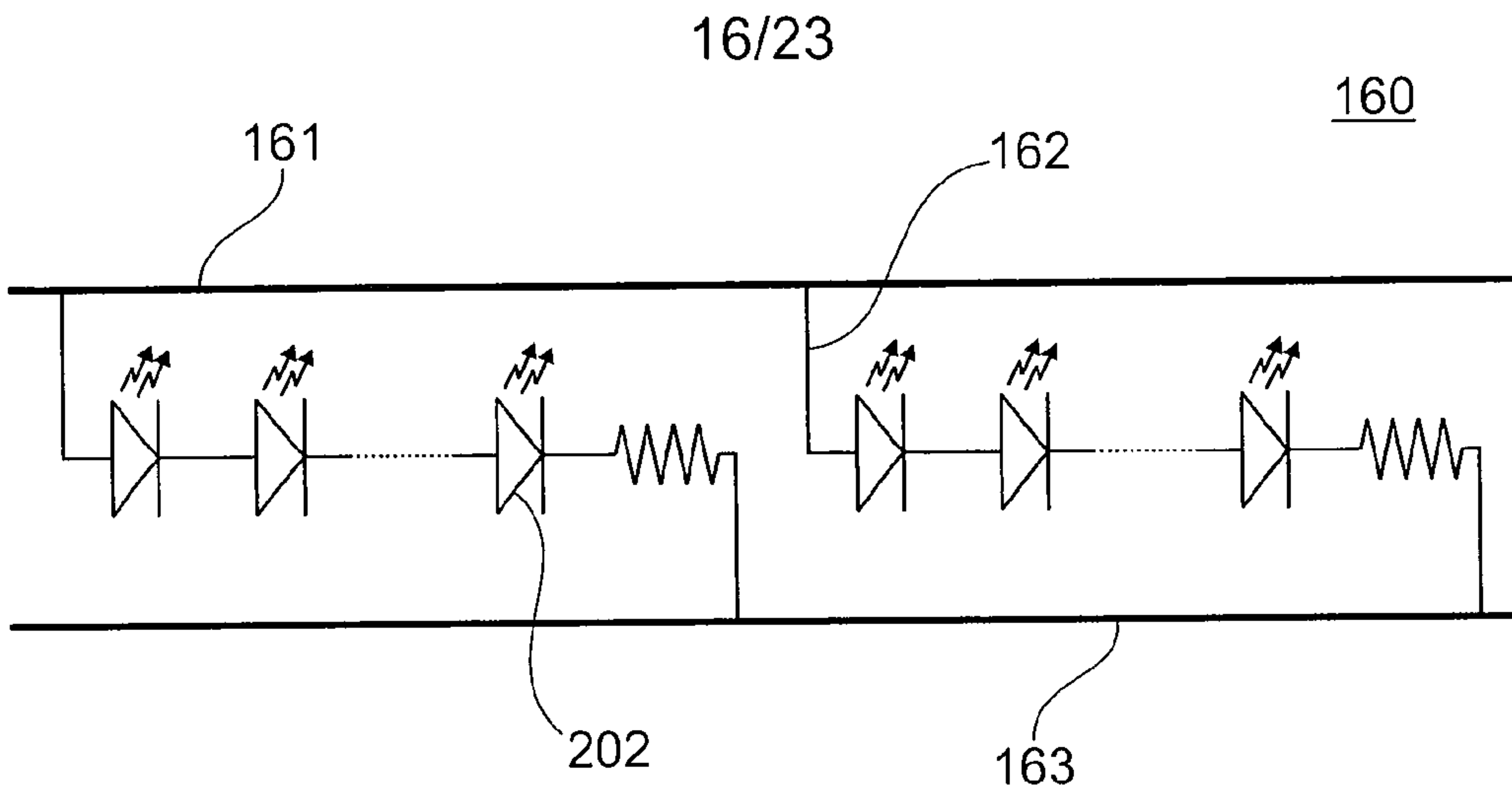

Fig. 16A

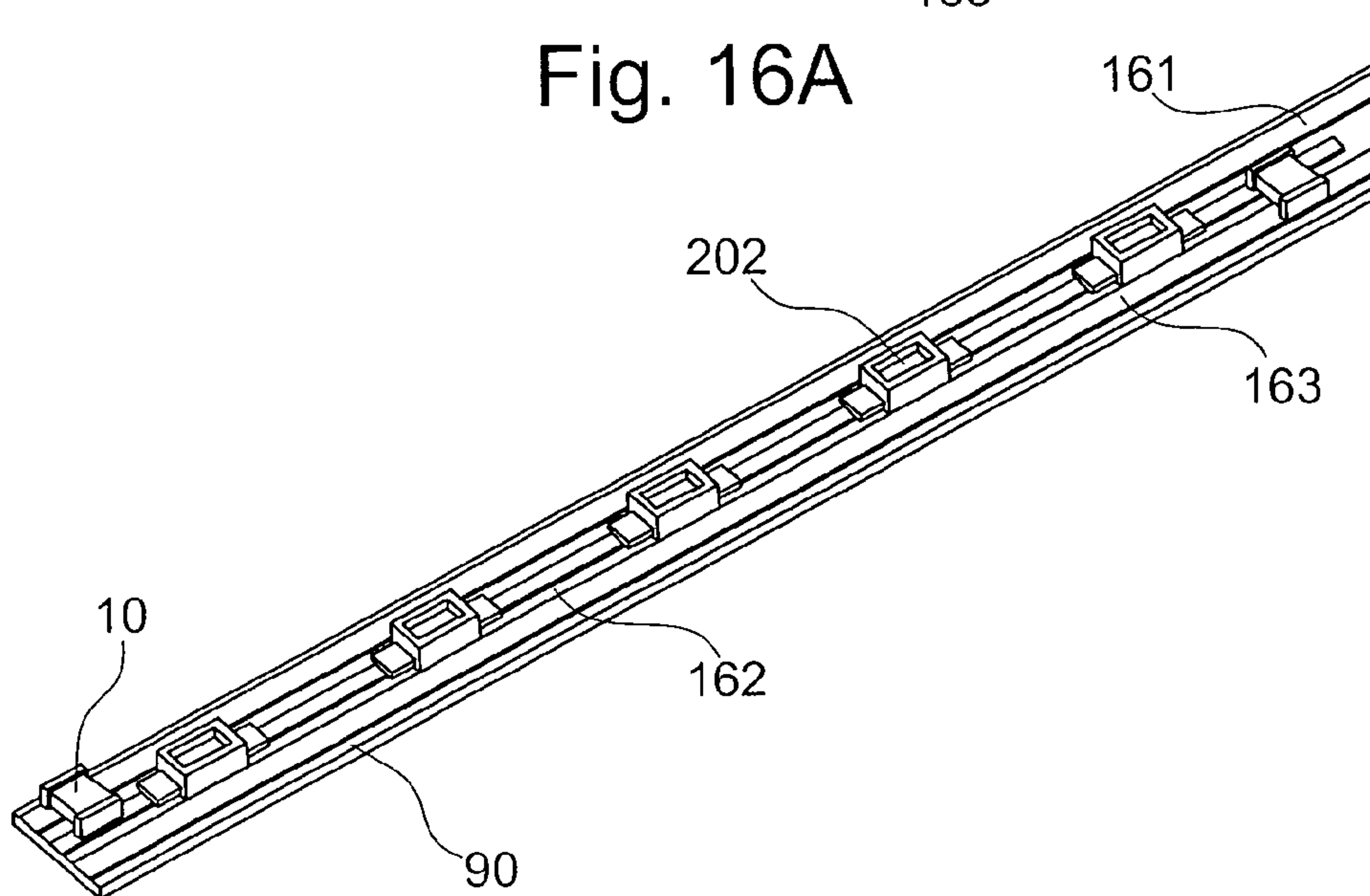

Fig. 16B

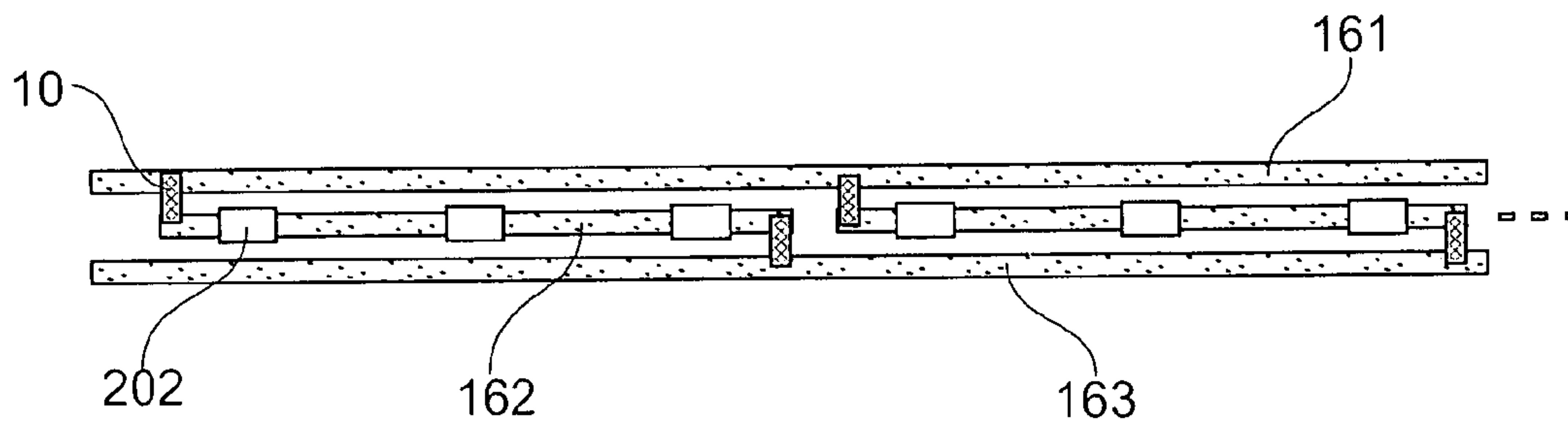

Fig. 16C

17/23

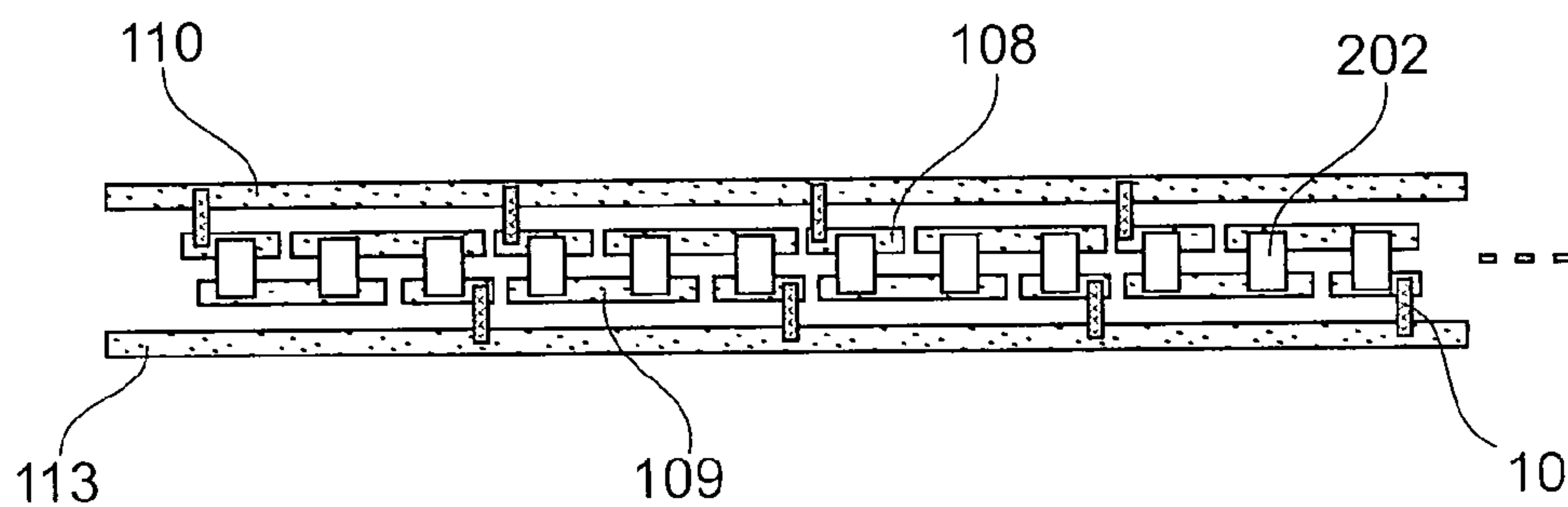

Fig. 17A

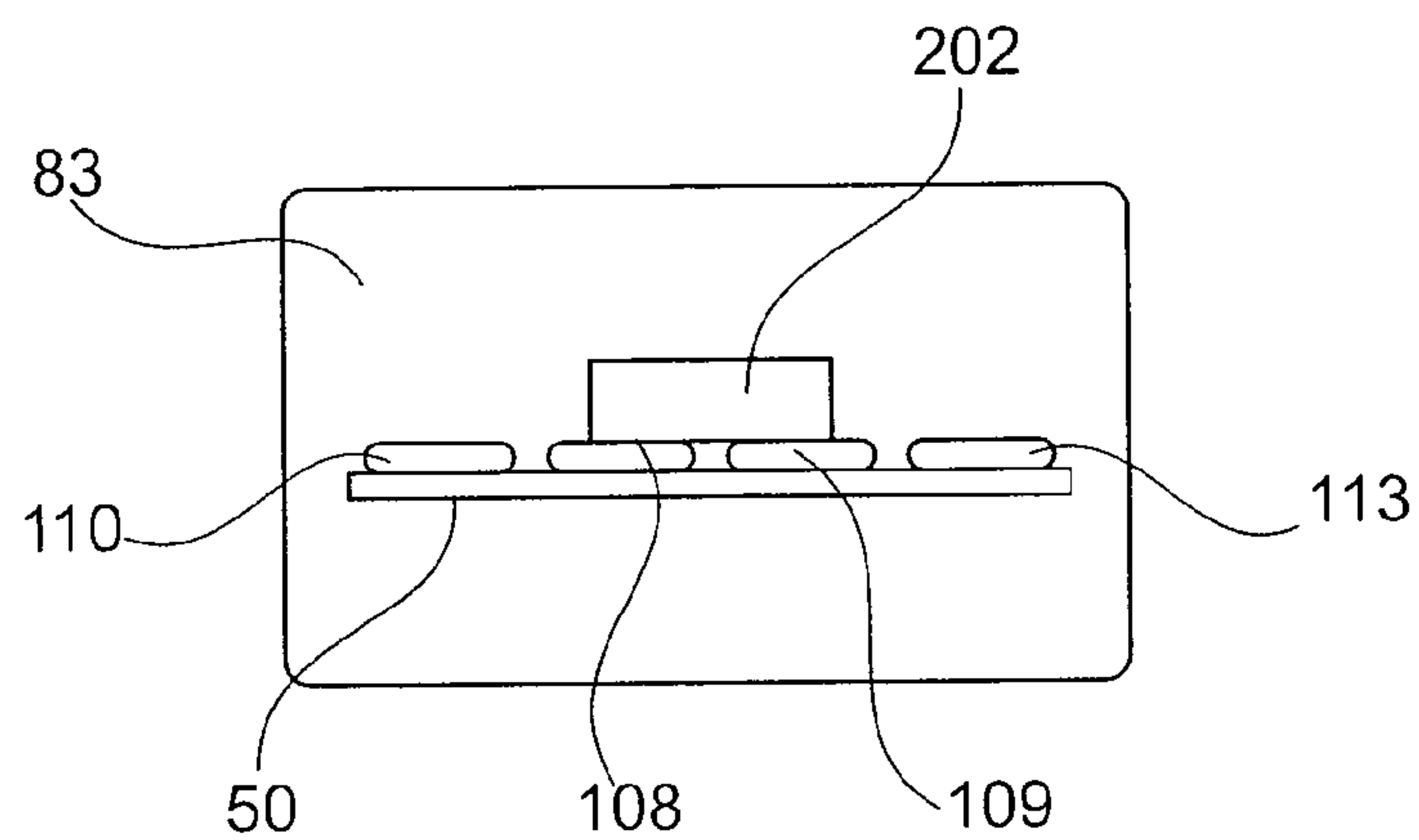

Fig. 17B

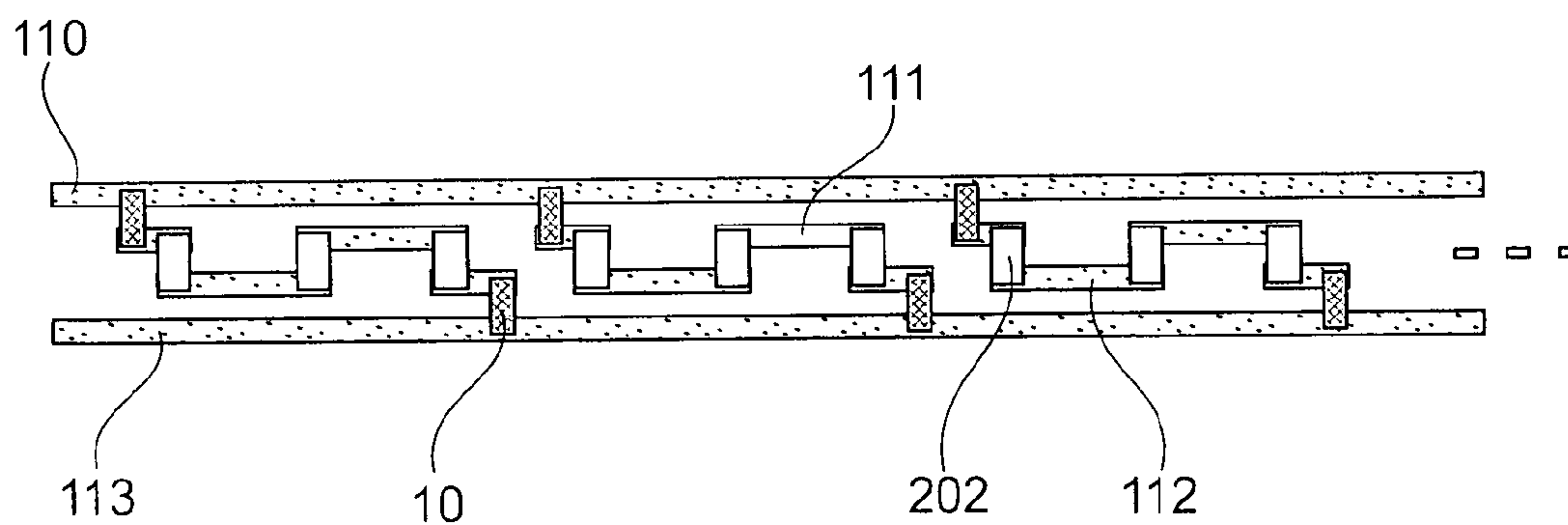

Fig. 17C

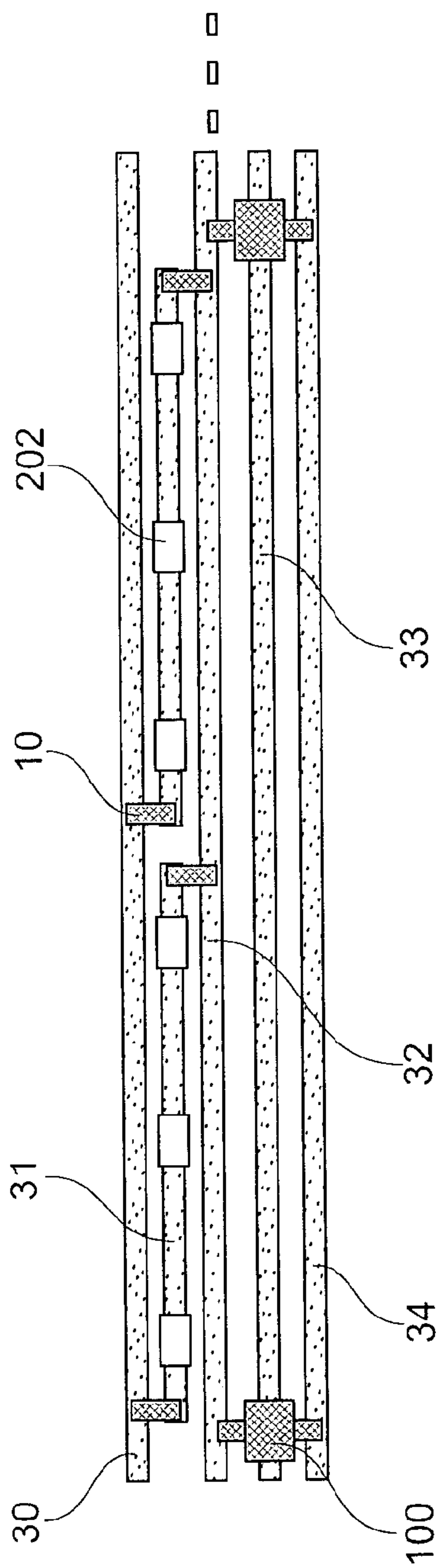

Fig. 18

19/23

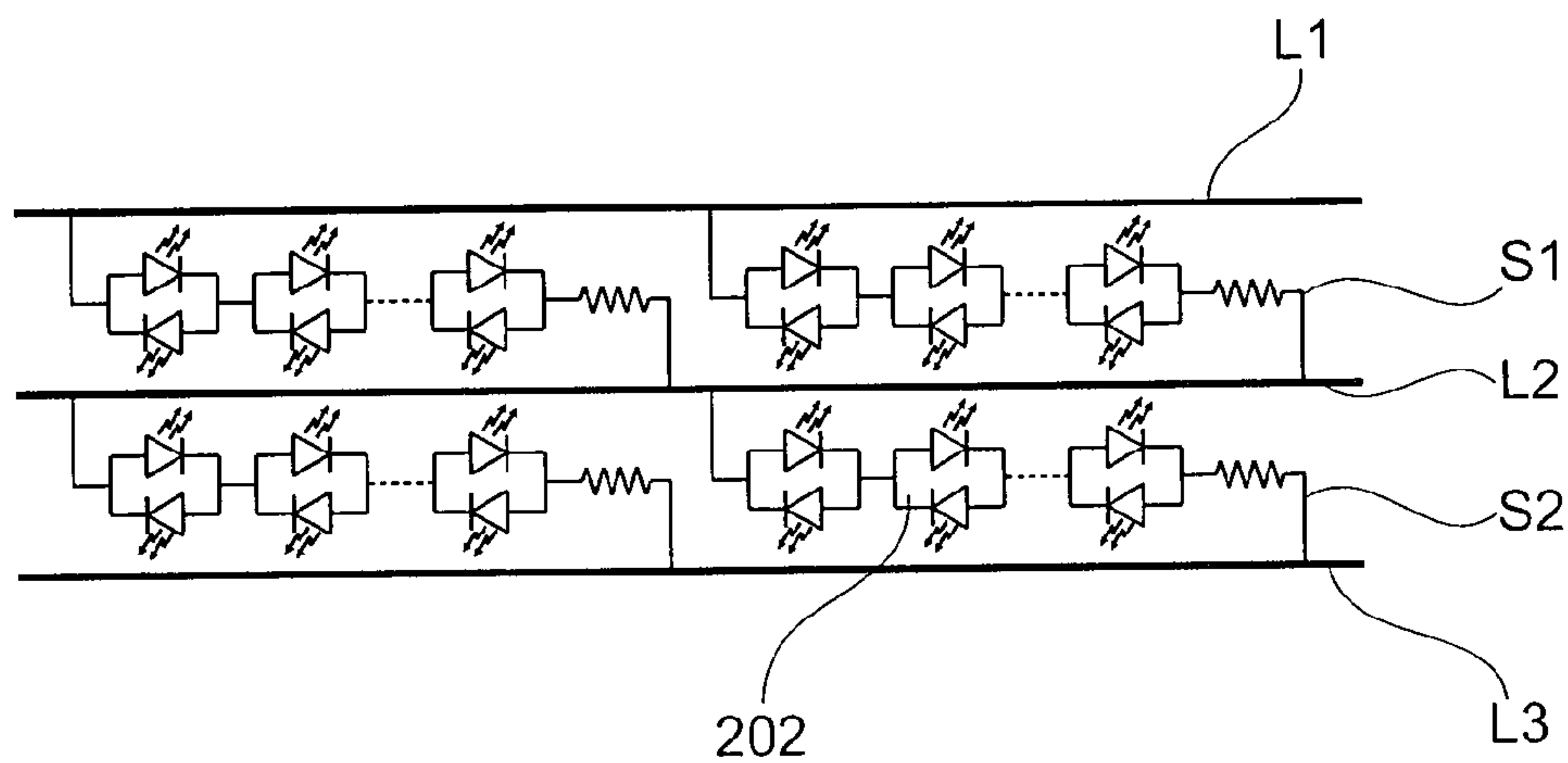

Fig. 19A

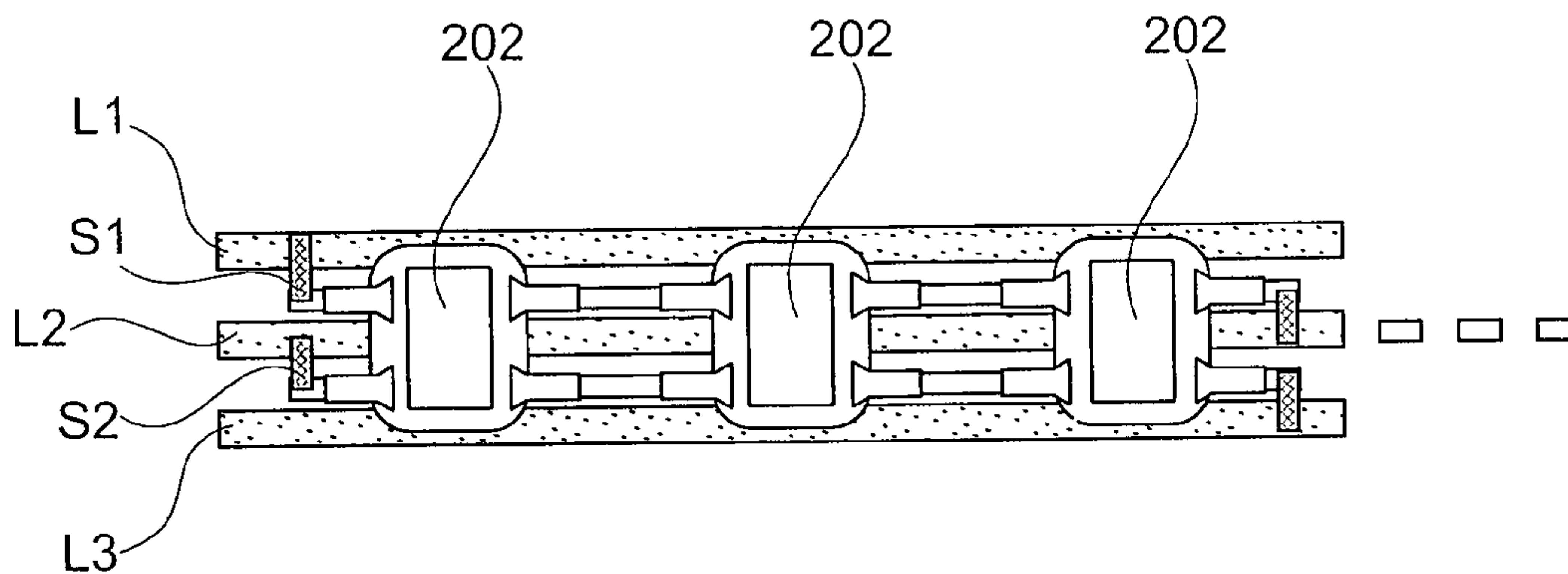

Fig. 19B

20/23

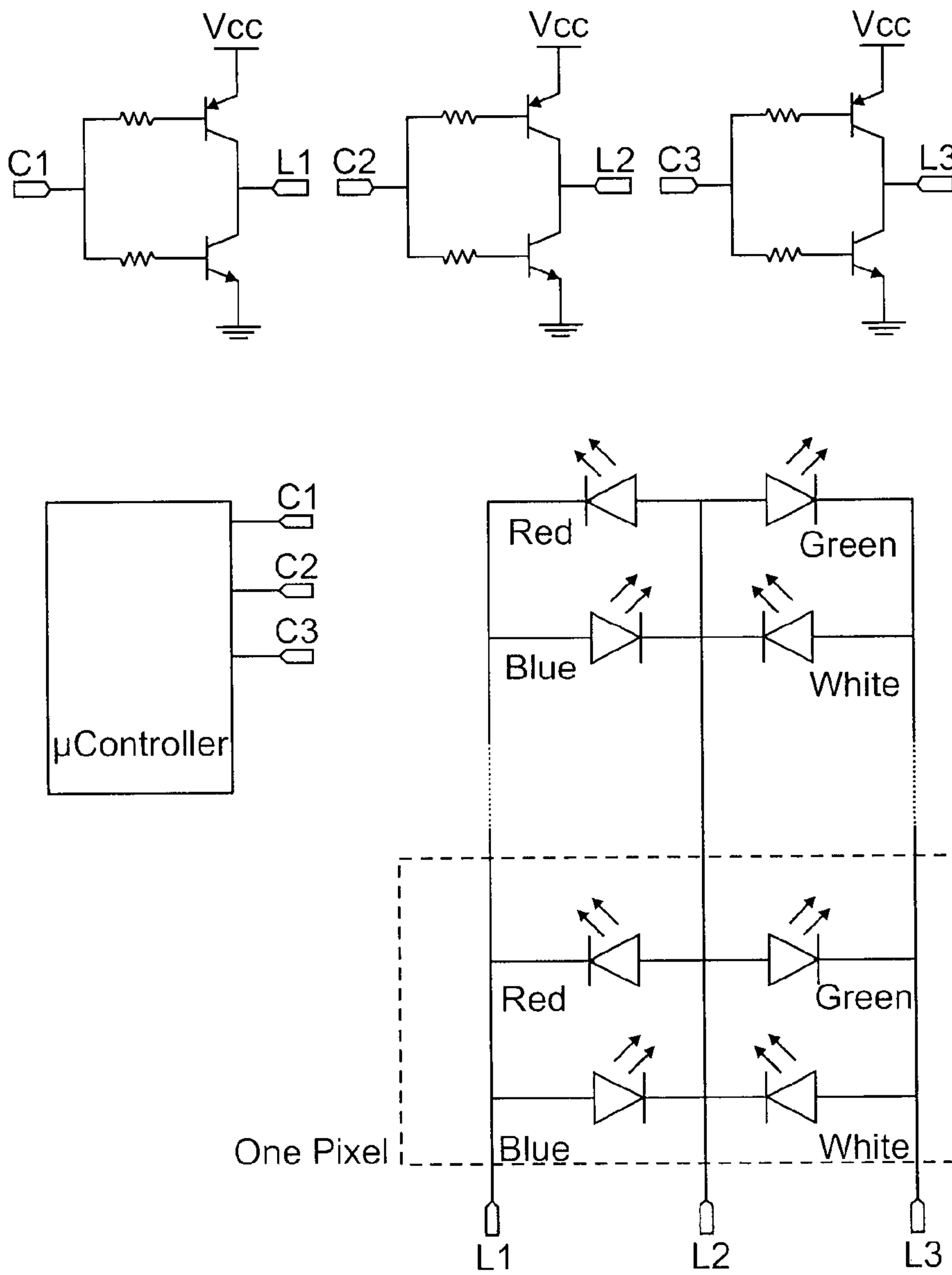

Fig. 20

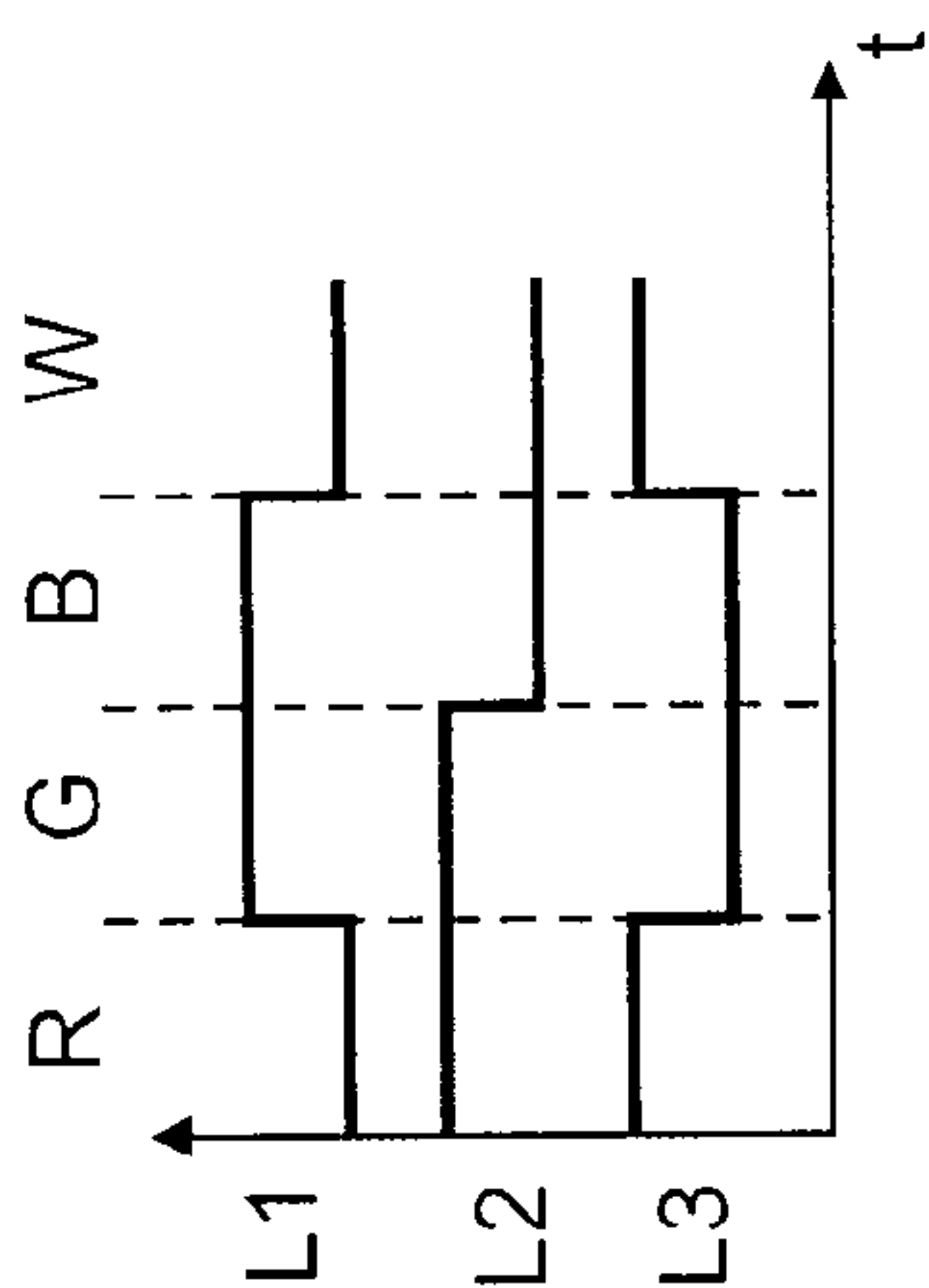

Fig. 21

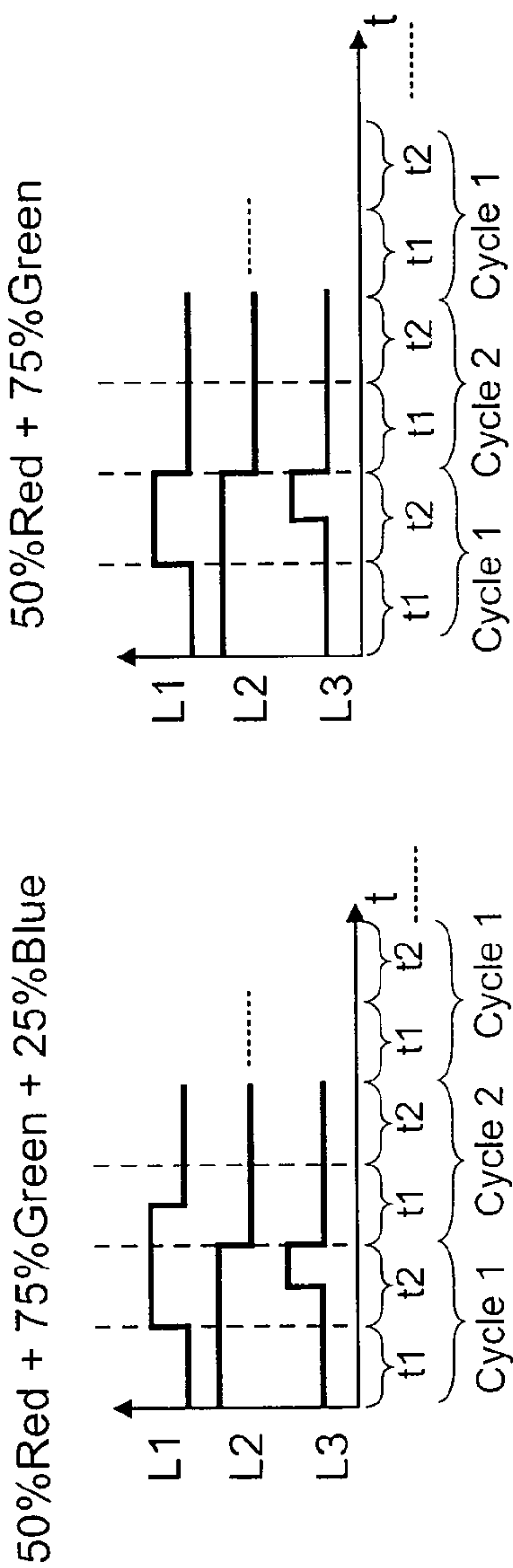

Fig. 22A

Fig. 22B

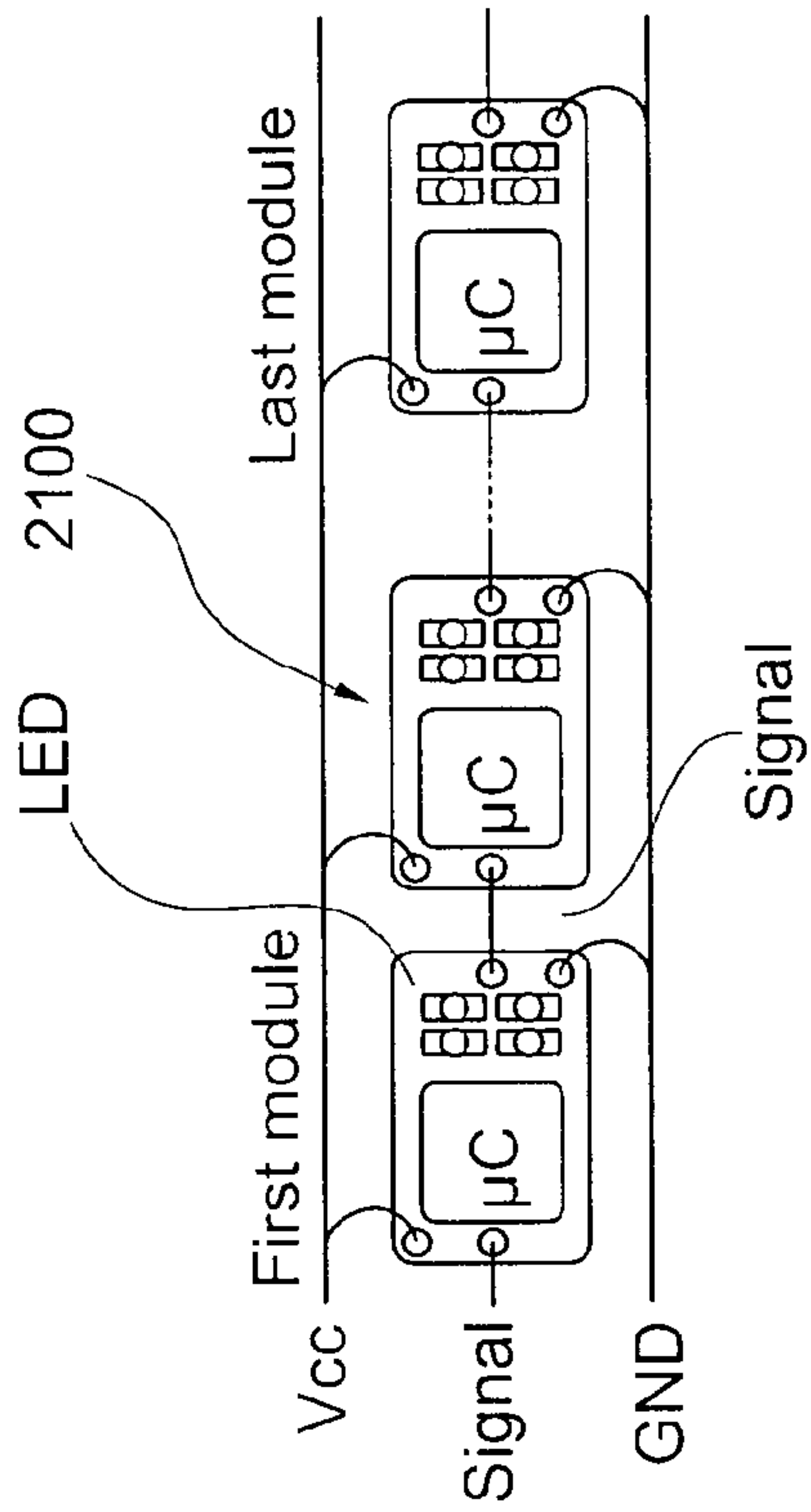

Fig. 23

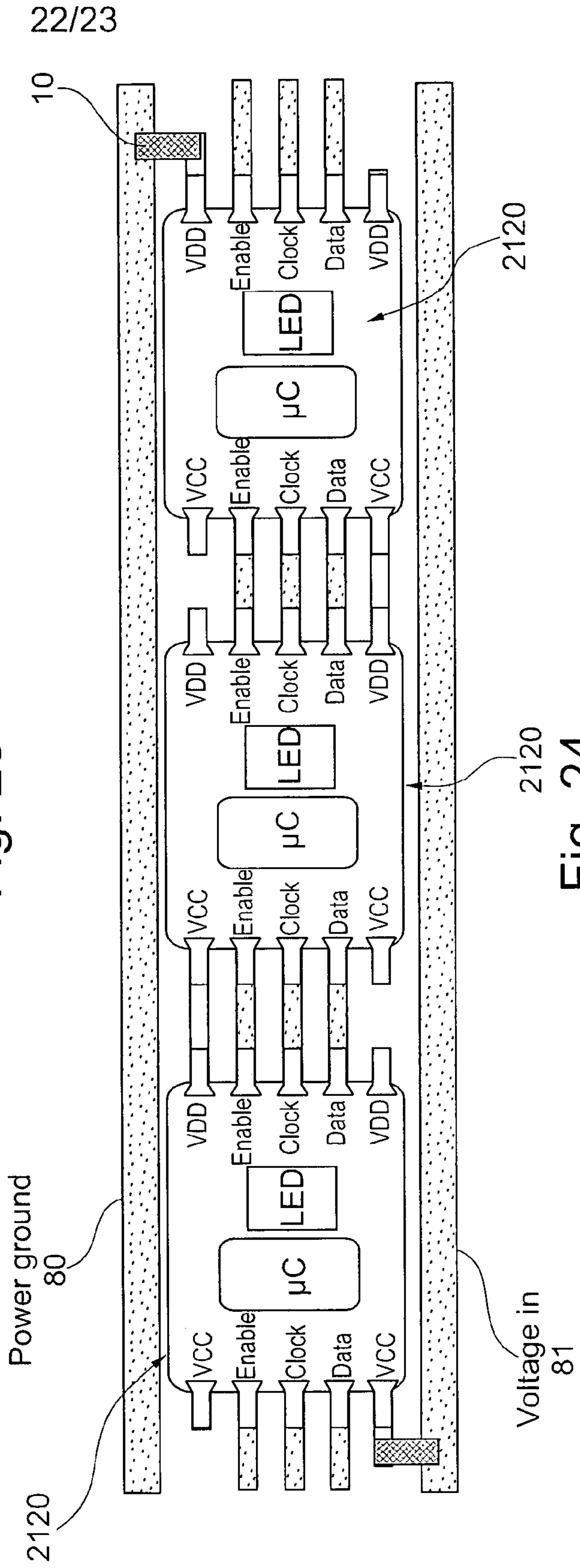

Fig. 24

3000

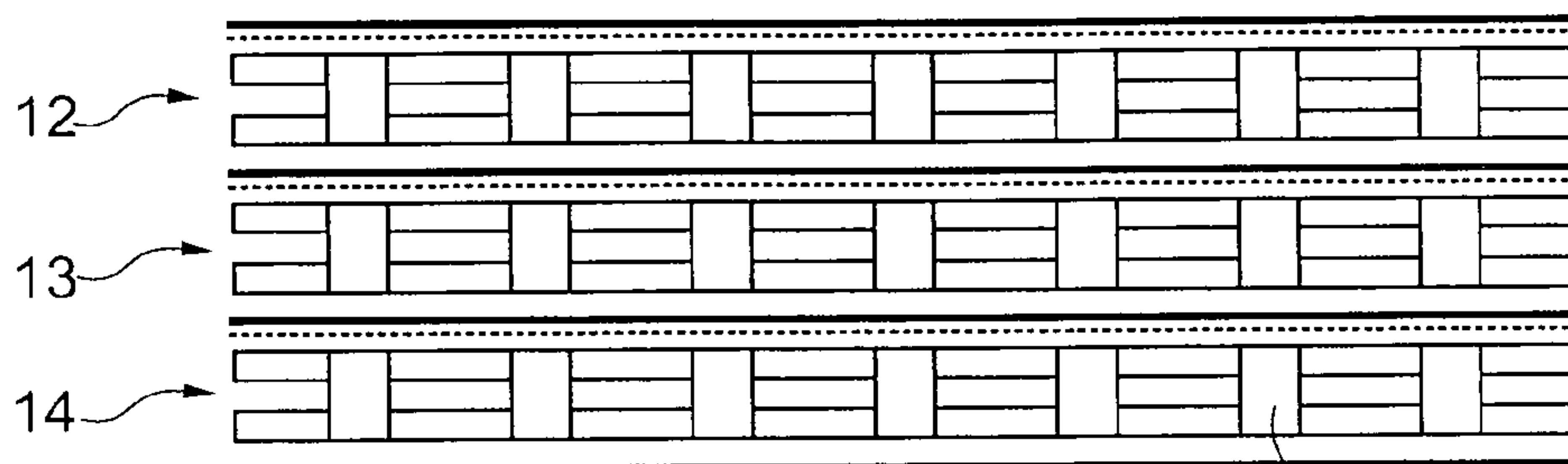

Fig. 25A

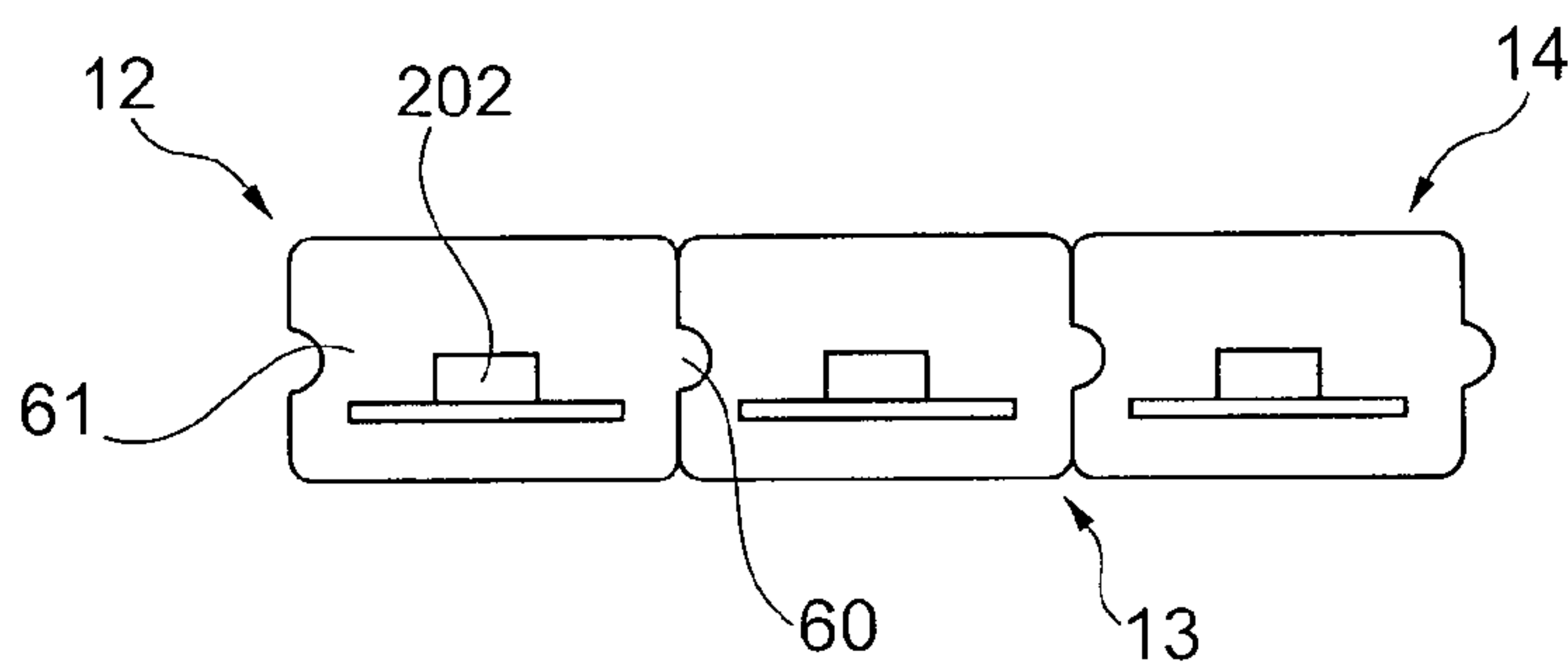

Fig. 25B

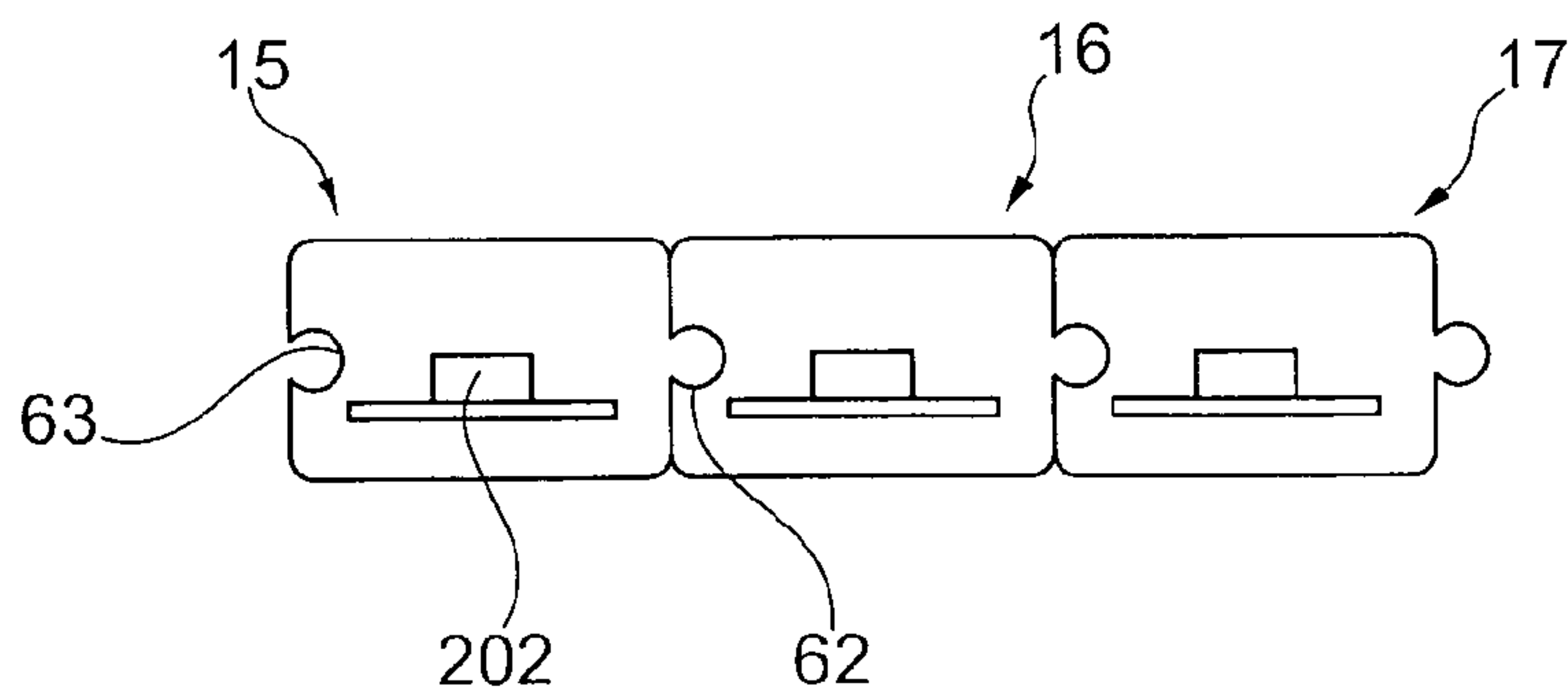

Fig. 25C

