

(No Model.)

4 Sheets—Sheet 1.

A. C. CAMPBELL.  
DOUBLE ACTING PRESS.

No. 526,892.

Patented Oct. 2, 1894.

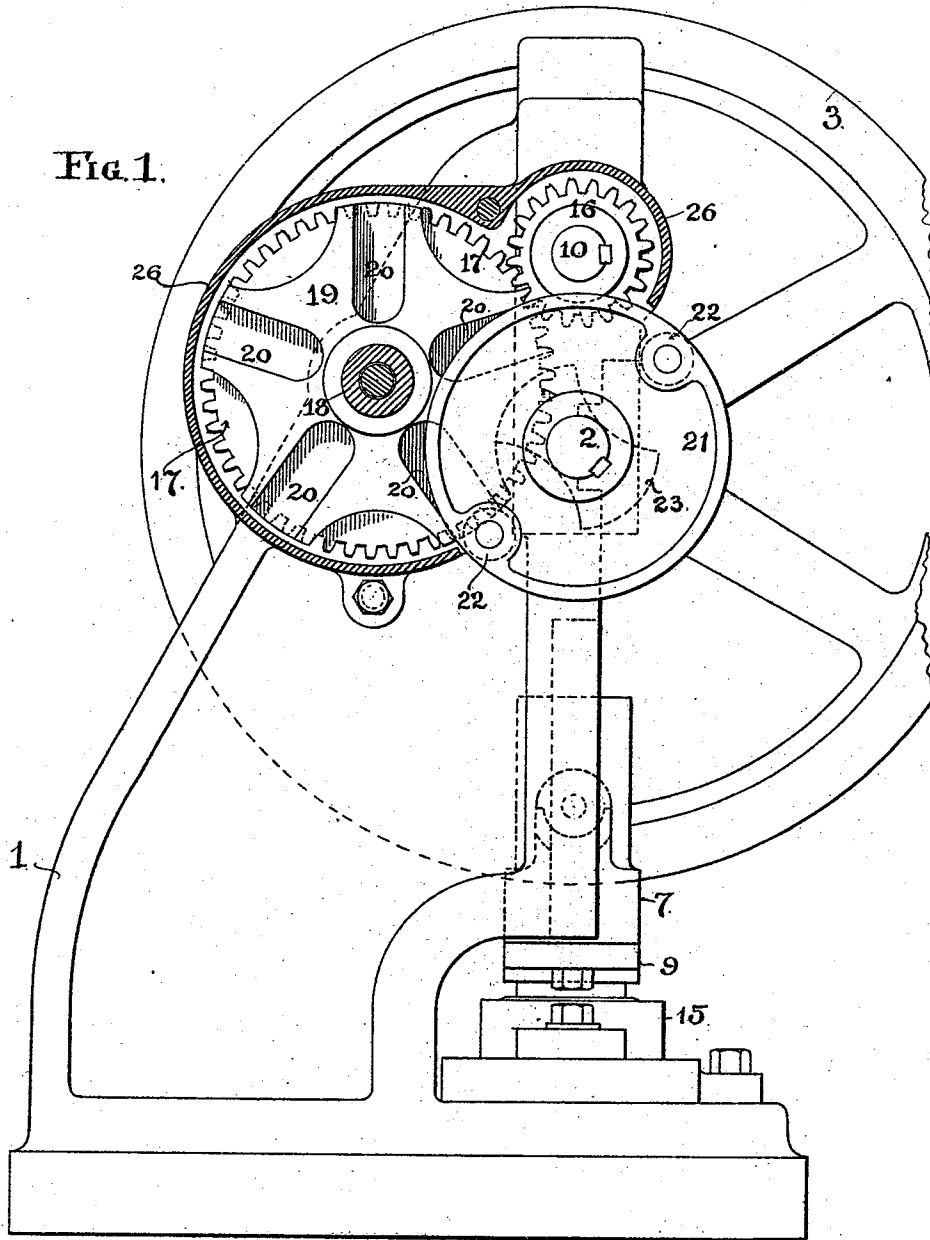

WITNESSES:

*Peter H. Ross*  
*J. W. Wiman*

INVENTOR

*A. C. Campbell*

BY

*Henry Coumes*

ATTORNEY.



(No Model.)

4 Sheets—Sheet 3.

A. C. CAMPBELL.  
DOUBLE ACTING PRESS.

No. 526,892.

Patented Oct. 2, 1894.

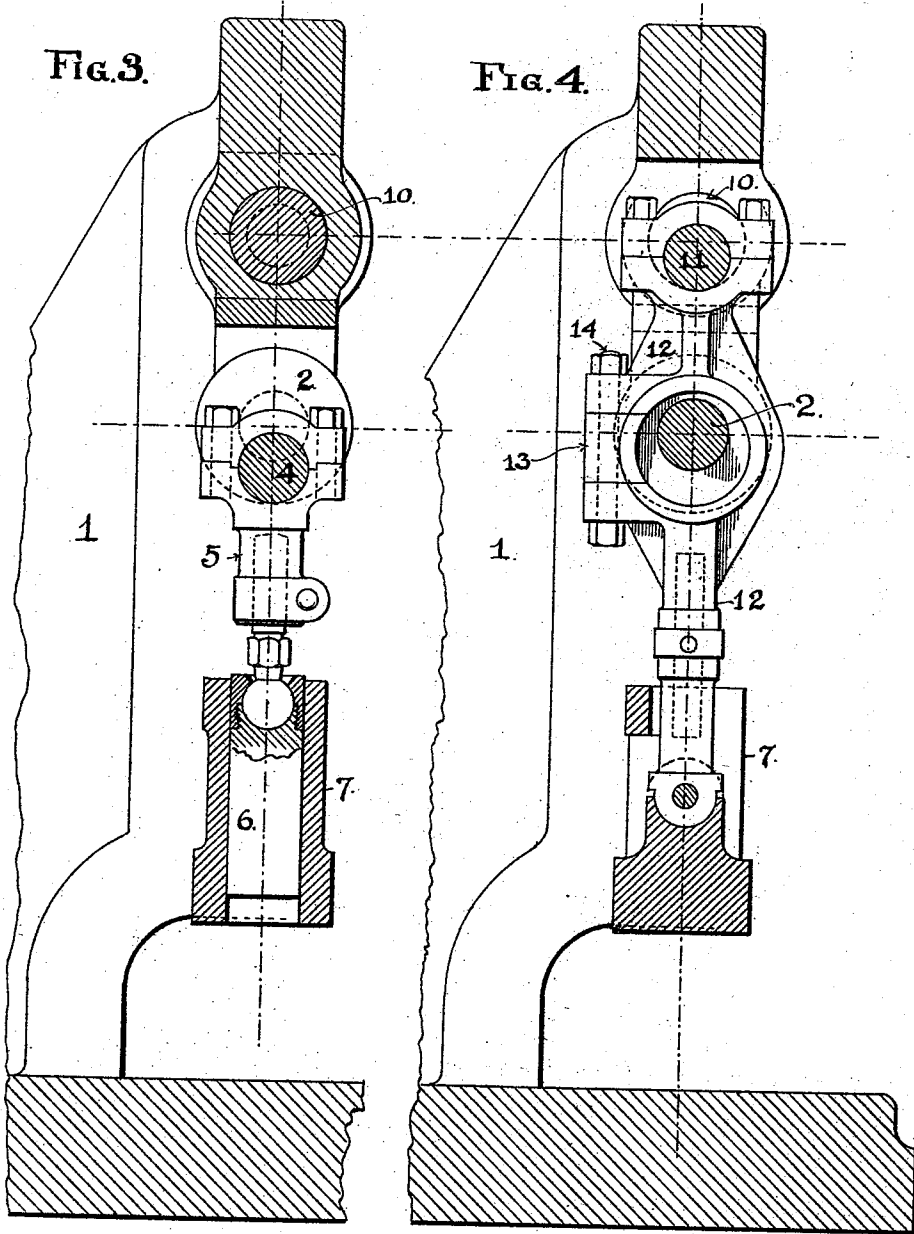

WITNESSES:

*John A. Ross*  
*J. W. Winters*

INVENTOR

*Audron C. Campbell*

BY *Henry Combs*

ATTORNEY

(No Model.)

4 Sheets—Sheet 4.

A. C. CAMPBELL.  
DOUBLE ACTING PRESS.

No. 526,892.

Patented Oct. 2, 1894.

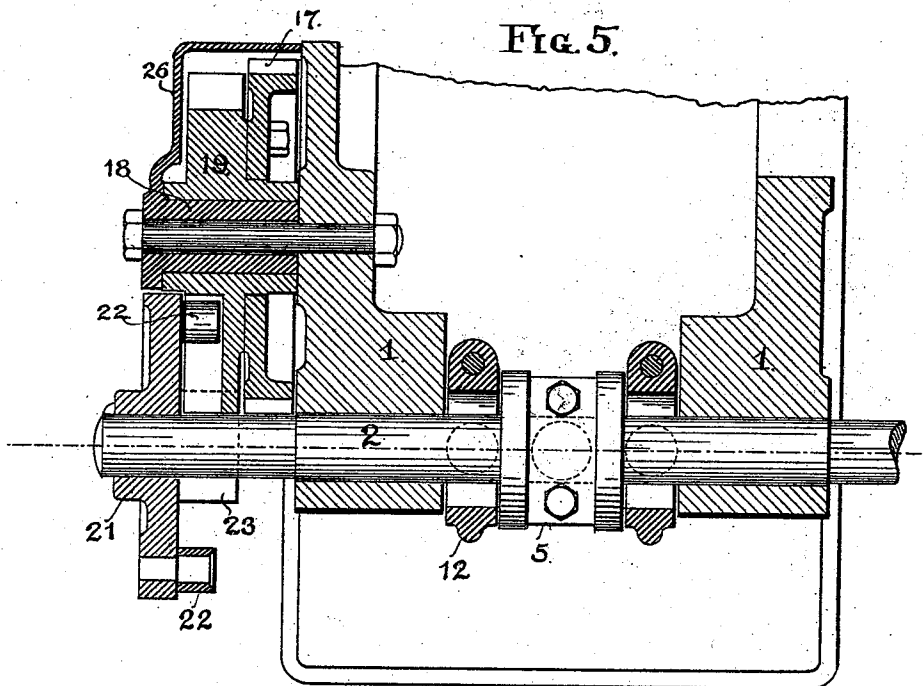

FIG. 5.

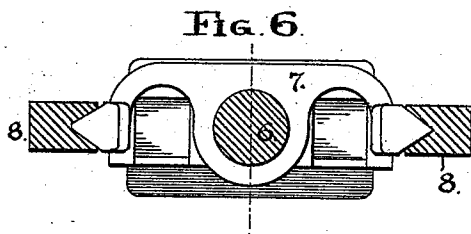

FIG. 6.

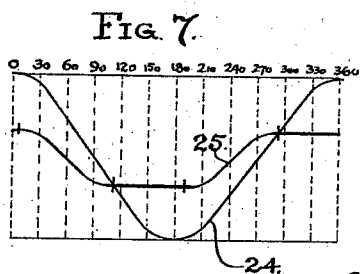

FIG. 7.

WITNESSES:  
*Peter A. Ross*  
*J. W. Wiman*

INVENTOR  
*Andrew C. Campbell*  
 BY *Henry Coumbs*  
 ATTORNEY

# UNITED STATES PATENT OFFICE.

ANDREW C. CAMPBELL, OF WATERBURY, CONNECTICUT.

## DOUBLE-ACTING PRESS.

SPECIFICATION forming part of Letters Patent No. 526,892, dated October 2, 1894.

Application filed June 4, 1894. Serial No. 513,350. (No model.)

*To all whom it may concern:*

Be it known that I, ANDREW C. CAMPBELL, a citizen of the United States, residing in Waterbury, New Haven county, Connecticut, have invented certain new and useful Improvements in Double-Acting Presses, of which the following is a specification.

My invention relates to the class of power presses such as are commonly employed for drawing, cupping, punching and otherwise working sheet metals. In this class of presses a reciprocating blank-holder is employed for the purpose of clamping down the margin of the blank or sheet, while the drawing slide, punch, or upper die is operating, and it is desirable that the movements of the blank-holder shall be intermittent; that is, there shall be a dwell, or cessation of movement, at the respective ends of its stroke. The dwell at the upper terminus of the stroke allows time for the insertion of the blank or sheet, and that at the lower terminus of its stroke permits the die to operate while the blank or sheet is being firmly held. It is desirable, also to effect this operation of the blank-holder with as little friction as possible and consequently with as little loss of power, as possible.

To this end the object of my invention is to provide a press with mechanism for reciprocating the upper die or punch, and a novel mechanism, operating in unison with the die-operating mechanism, for imparting the proper non-continuous reciprocating motion to the blank-holder.

The invention will be fully described hereinafter and its novel features carefully defined in the claims.

In the accompanying drawings—Figure 1 is an elevation of the left-hand side of a press embodying my invention, with a part of the gearing-guard broken away to show the gearing more clearly. Fig. 2 is a front elevation of the press, with one of the gate-operating, connecting links in section. The gearing-guard is removed in this view. Fig. 3 is a vertical section taken in the plane indicated by line  $x, x$ , in Fig. 2, illustrating the mechanism whereby the upper die, drawing slide, or punch is actuated. Fig. 4 is a vertical section taken in the plane indicated by the line

$y, y$ , in Fig. 2, illustrating the construction of one of the links for operating the gate carrying the blank-holder. Fig. 5 is a horizontal section taken in the plane of the axis of the main driving shaft. Fig. 6 is a horizontal section through the upper die or drawing slide and the guides of the gate carrying the blank-holder, showing the gate in plan. Fig. 7 is a diagram showing the relative movements of the blank-holder and upper die, as the mechanism is herein constructed and proportioned.

1, is a suitable strong frame, which may have any desired contour. Usually it will be made of cast iron.

2 is the main driving shaft, mounted in bearings in the frame and provided with a driving wheel or pulley, 3. In the shaft 2, is formed a crank, 4, to which is coupled at its upper end, a connecting-rod, 5. At its lower end the rod 5 has a ball-and-socket coupling to the upper die, punch, or drawing slide, 6. This construction is best seen in Fig. 3. The die 6 is guided in and plays through a gate, 7, mounted to reciprocate in guides, 8, on the frame. This gate 7 carries the blank-holder, 9. Indeed the gate and blank-holder might be integral if desired.

Mounted in the frame above the main shaft 2, is a crank-shaft, 10, in which are formed two cranks, 11; and to these cranks are coupled, respectively, two like connecting-rods or links, 12, which are coupled at their lower ends to the gate 7. This construction is best seen in Fig. 4. In order to pass the main shaft 2, the link 12 is widened and has in it an aperture through which the shaft 2 passes; and for convenience in mounting the link 12 after the main shaft is in place, a way or gate is cut or formed in the ring-like, widened part of the link, said gate being broad enough to admit the main shaft, and this gate or way is afterward filled by a block, 13 (see Fig. 4) and secured by a bolt, 14. The links 12, as well as the connecting-rod 5, are made adjustable as to length by screws in a well known way. On the bed of the frame is mounted the lower die, 15.

I will now describe the mechanism whereby continuous rotation of the main driving-shaft 2, imparts non-continuous or intermittent rotary motion to the crank-shaft 10, which lat-

ter operates the blank-holder. This mechanism is best seen in Figs. 1, 2 and 5, and I will describe it as proportioned herein, premising that these proportions may be varied.

5 On the crank-shaft 10, is fixed a gear-wheel, 16, having twenty teeth, which gears with a wheel, 17, having fifty teeth. This wheel 17 rotates about a stud, 18, projecting from the frame. Fixed to the outer face of the gear-wheel 17, is a disk, 19, having in it five, equally spaced radial slots, 20, the peripheries of the segments between said slots being concave, as shown. On the outer end of the main shaft 2, and beyond the plane of the disk 19, is fixed  
15 a disk, 21, which bears on its inner face two studs, 22. These will be roller studs by preference and they are adapted, as the main shaft rotates, to enter the radial slots 20 and impart to the disk 19 intermittent rotary impulses. These impulses being communicated to the cam-shaft 10, through the intermediate gears, 16 and 17, will impart to the shaft 10 intermittent half-rotations, with a dwell or rest when the cranks in shaft 10 are up and  
25 another dwell or rest when the said cranks are down.

Fig. 1 shows the positions of the parts when the cranks in shaft 10 have reached the end of their downward stroke. The lower stud 22  
30 is just leaving a slot 20. The upper stud 22 has yet some distance to travel before it can enter the next succeeding slot 20 and again set the shaft 10 to rotating. As the gearing is here shown each stud 22 turns the wheel 17 through one-fifth of a complete rotation, and the wheel 17 turns the wheel 16, at the same time through one-half of a complete rotation. The proportions of the disks 19 and 21 are such that after one stud 22 ceases to operate  
40 the disk 19, the main shaft 2 will rotate through about eighty degrees before the next stud 22 comes into operation. These relations may be varied by varying the proportions of the elements described.

45 In order to hold the crank-shaft 10 against accidental movement during the periods of rest, or in other words to provide it with a positive stop, I fix on the main shaft 2, at the inner face of the disk 21, and in the same plane as the disk 19, a stop-disk 23, having two oppositely arranged convex faces which engage in turn the concave faces on the disk 19 and lock the latter against rotation. This stop device (seen in dotted lines in Fig. 1) is  
50 not of itself new, being similar to the well known "Geneva stop" used in watch movements.

In order to make more clear the relative movements of the upper die and the blank-holder, I have represented them diagrammatically in Fig. 7, wherein the vertical lines designate the degrees moved through by the cranks, and the horizontal lines the limits of the strokes of the cranks. The curved line  
65 24 represents the movement of the die and the partly curved and partly straight line 25, represents the movement of the blank-holder,

the straight portions indicating the dwells or rests.

The gearing and disks last described for 70 operating the blank-holder may be inclosed in a housing or guard, 26, secured to the frame. In Fig. 1 this guard is represented broken away and it is omitted from Fig. 2.

I have used the term die for the part 6, but 75 this is sometimes called a drawing slide or punch, as the case may be. The gate 7 is merely the carrier for the blank-holder 9 and these two parts may be considered as one.

It will be seen that the object of mechanism 80 intermediate the driving shaft 2 and cam-shaft 10 is to convert the continuous rotary motion of the former into intermittent half-rotations of the latter, the intermittent impulses being alternated with rests; and this 85 might be effected by some other form of gearing or train intermediate the continuously rotating shaft 2 and the intermittently rotating shaft 10. I do not therefore wish to limit myself to the specific intermediate gearing here- 90 in shown.

Having thus described my invention, I claim—

1. In a press of the character described, the combination with the dies and the rotating 95 main shaft from which the moving die is driven, of the reciprocating gate provided with the blank-holder, the crank-shaft 10, connections between the gate and said crank-shaft whereby rotation of the latter imparts 100 a reciprocatory movement to the former, and intermediate driving and converting mechanism between the main shaft and the crank-shaft for converting continuous rotary motion of the former into intermittent rotary motion 105 of the latter, substantially as set forth.

2. In a press of the character described, the combination with the dies and the rotating main shaft from which the moving die is 110 driven, of the reciprocating gate provided with the blank-holder, the crank-shaft 10, the connections between the gate and said crank-shaft whereby rotation of the latter imparts a reciprocatory movement to the former, a rotatable, radially slotted disk 19, studs 22, 115 carried by the main shaft and adapted to engage the slots in the disk 19 and thus impart intermittent rotary motion to said disk, and gearing intermediate the disk 19 and shaft 10, whereby the motion of the former is im- 120 parted to the latter, substantially as set forth.

3. In a press of the character described, the combination with the main shaft 2, the dies, and the connecting-rod coupling the moving die to the crank in the main shaft, of the 125 crank-shaft 10, the reciprocating gate provided with the blank-holder, a link connection between the crank in the shaft 10 and the gate, the rotatively mounted, radially slotted disk 19, having concaves in its periphery 130 as described, the studs 22, carried by the main shaft and adapted to engage the slots in the disk 19, the stop-disk 23, on the main shaft, and its convex ends adapted to engage the

concaves in the disk 19, and gearing between the disk 19 and shaft 10, whereby the former drives the latter intermittently.

4. In a press of the character described, the  
5 combination with the gate 7, the crank-shaft 10, and the links connecting the gate with the cranks in said shaft, of a rotatable, radially slotted disk 19, geared to the crank-shaft, and a continuous rotating disk 21, provided with  
10 studs 22, adapted to engage the slots in the

disk 19 and impart thereto intermittent rotary impulses alternating with rests, substantially as and for the purposes set forth.

In witness whereof I have hereunto signed my name in the presence of two subscribing  
15 witnesses.

ANDREW C. CAMPBELL.

Witnesses:

J. M. GALLOND,  
GEO. ROWBOTTOM.