

(No Model.)

C. C. RICHMOND.
HASP FASTENER.

No. 575,493.

Patented Jan. 19, 1897.

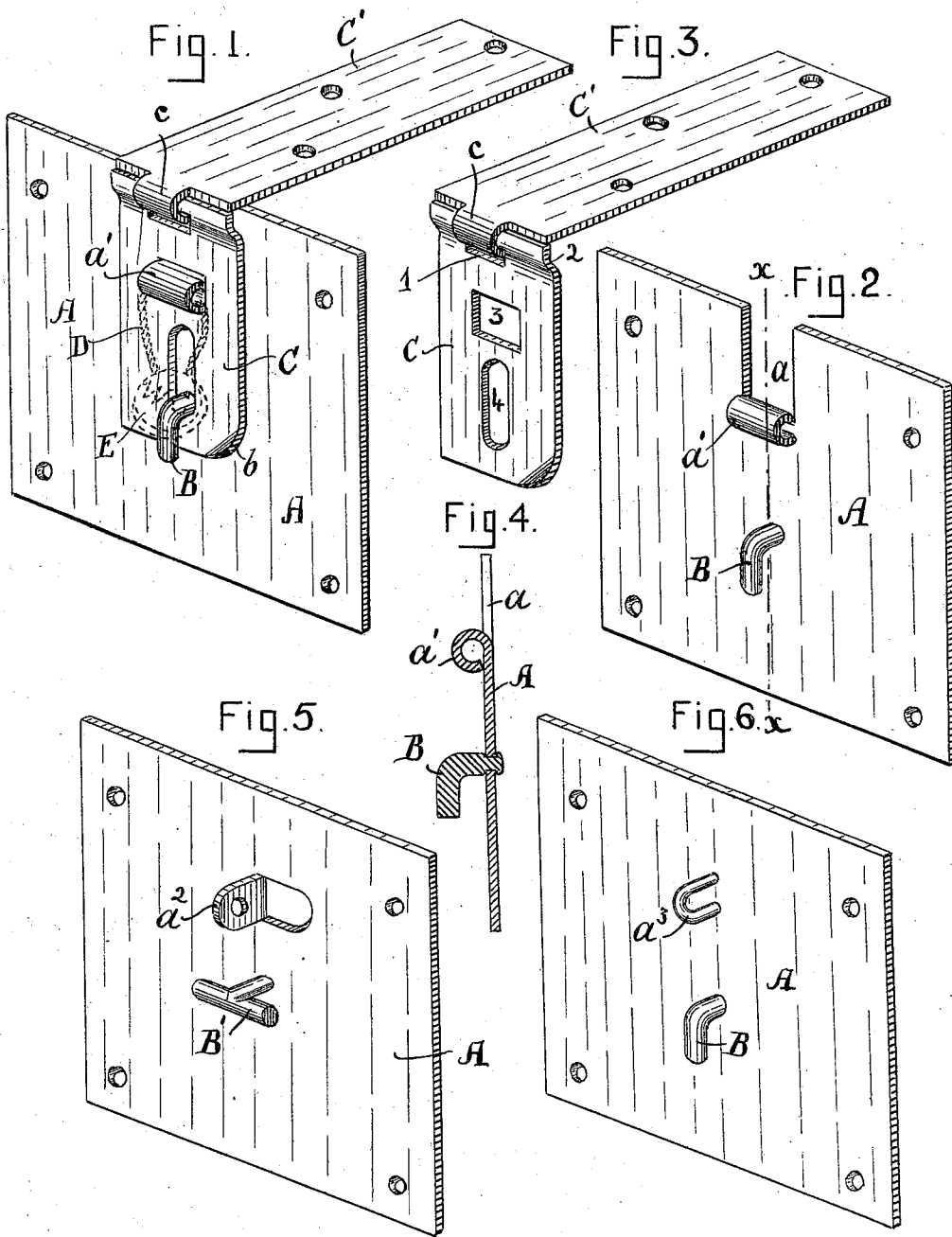

Witnesses.

Winfred J. Kewin.
Lama C. Hayward.

Inventor.

Charles C. Richmond
by Edwin Blanta,
Attorney.

UNITED STATES PATENT OFFICE.

CHARLES C. RICHMOND, OF BOSTON, MASSACHUSETTS.

HASP-FASTENER.

SPECIFICATION forming part of Letters Patent No. 575,493, dated January 19, 1897.

Application filed May 3, 1894. Serial No. 509,960. (No model.)

To all whom it may concern:

Be it known that I, CHARLES C. RICHMOND, a citizen of the United States, residing at Boston, in the county of Suffolk and State of Massachusetts, have invented certain new and useful Improvements in Hasp-Fasteners, of which the following, taken in connection with the accompanying drawings, is a specification.

10 My invention relates to that class of fastenings known as "hasp-fasteners," and is particularly applicable for boxes or cases that are to be returned empty.

15 The invention consists in certain details of construction, as hereinafter fully described, and pointed out in the claim.

Referring to the accompanying drawings, Figure 1 represents a perspective view of a seal-lock embodying my invention. Fig. 2 is a similar view of the plate, and Fig. 3 is a view of the hasp. Fig. 4 is a vertical section of the plate, taken on line *xx* of Fig. 2. Figs. 5 and 6 are views of modifications of the plate.

25 A represents a plate which at the central portion of its upper edge is cut down, as shown at *a*, (see Fig. 2,) the central piece being bent into an eye or loop *a'*. A short distance below the loop *a'* a hole is punched, in which is inserted one end of an angle-piece 30 B, that forms the catch or fastener, the inner end of which is riveted over on the inside of the plate A (see Fig. 4) to hold it in place, but not tight enough to interfere with its being turned easily.

35 C is the hasp, attached to a plate C' in the manner shown, that is, the plate C' is cut away on each side of its front end and the projecting piece bent over to form an eye or loop *c*, which passes through a rectangular slot 1, formed in the upper end of the hasp C, which end is formed with an offset 2 to bring the upper edge of the hasp forward, so that it can turn freely. The hasp is formed with two slots 3 4, the slot 3 for the eye or 45 loop *a'* to pass through and the slot 4 for the catch or fastener B to pass through.

When in use, the plate A is secured to the

front of the box or case, preferably to the inner side, a slot being cut in the front of the box to allow the hasp to close onto the plate 50 A. The hasp-plate C' is secured to the inside of the cover and the hasp C falls down on the front of the plate A, the eye or loop *a'* passing through the slot 3, and the fastener B (which has previously been turned so as to 55 project upward) through the slot 4. The fastener B is then turned down and securely holds the hasp C in contact with the plate A. The wire D of the seal is then passed through the eye *a'* and the seal E applied to the ends 60 thereof. Thus the hasp cannot be raised without first removing the wire and seal.

Of course when the box or case is returned empty a seal is not required, as the fastener B will securely hold the lid in place. 65

Instead of cutting the plate A and curling it to form an eye a piece might be stamped out and bent, as shown at *a²* in Fig. 5, or a staple might be riveted to the plate, as shown at *a³* in Fig. 6, and instead of having an angle 70 fastener, as described, the fastener might be of T form, as shown at B' in Fig. 5.

One corner of the hasp C may be bent up, as shown at *b*, so that the hasp can be easily raised by the finger. 75

What I claim is—

A seal-lock consisting of a plate A, having an eye *a'*, formed by cutting down and curling the central upper portion of said plate and a pivoted fastener B, attached to said 80 plate A below the eye *a'*, in combination with a hasp C, having an opening 3, for the eye *a'*, to pass through and an opening 4, for the fastener B, to pass through and a hasp-plate C', fulcrumed to said hasp C, substantially as 85 and for the purpose set forth.

In testimony whereof I have signed my name to this specification, in the presence of two subscribing witnesses, on this 23d day of April, A. D. 1894.

CHARLES C. RICHMOND.

Witnesses:

CHAS. STEERE,
EDWIN PLANTA.