

Jan. 23, 1951

G. H. LELAND

2,539,090

ELECTROMAGNETICALLY OPERATED DEVICE

Filed May 18, 1948

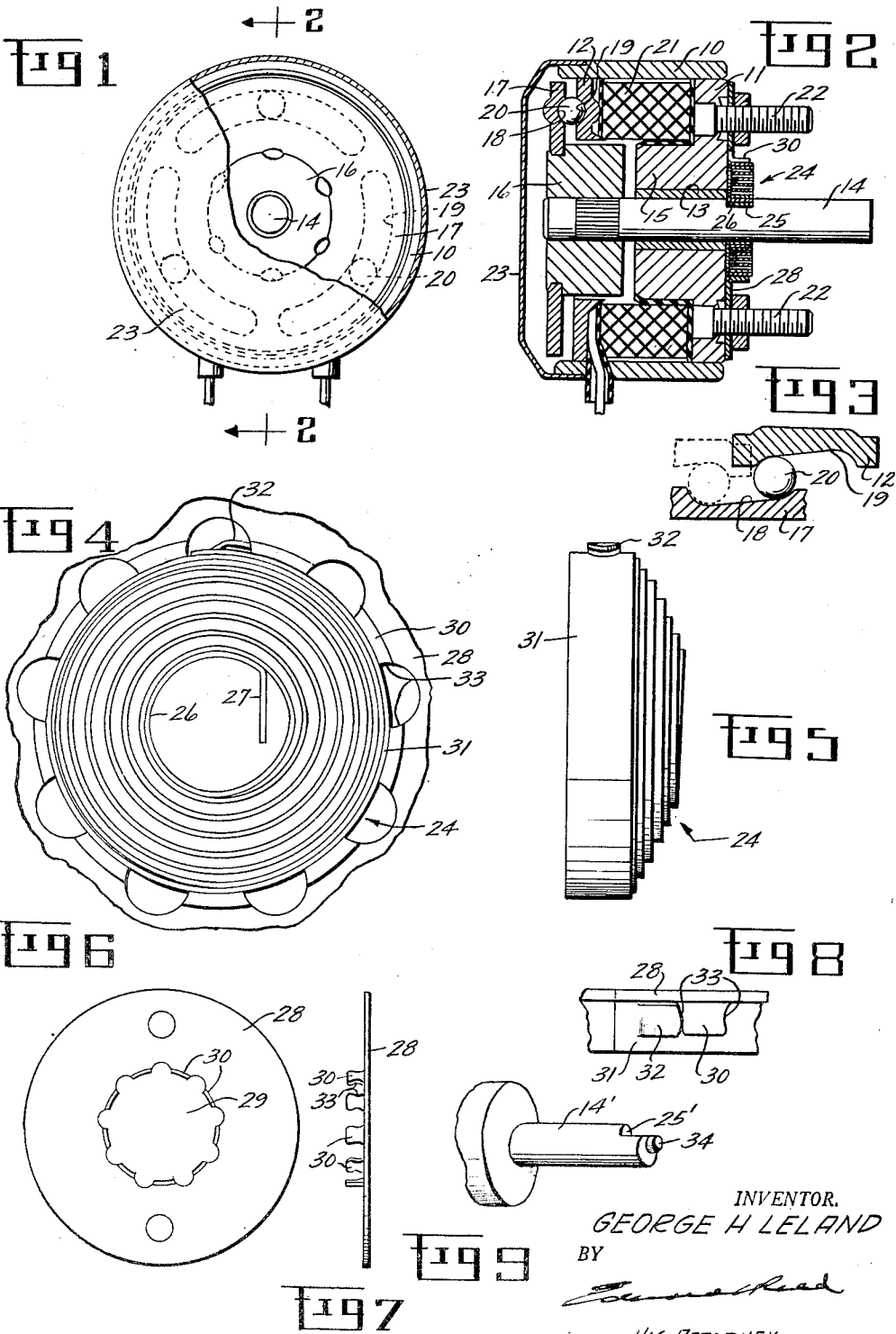

INVENTOR.  
GEORGE H LELAND  
BY  
*James H. Read*  
HIS ATTORNEY-

# UNITED STATES PATENT OFFICE

2,539,090

## ELECTROMAGNETICALLY OPERATED DEVICE

George H. Leland, Dayton, Ohio

Application May 18, 1948, Serial No. 27,794

3 Claims. (Cl. 74-99)

1

This invention relates to an electromagnetically operated device and more particularly to a rotary solenoid of the type shown and described in my pending application Serial Number 542,188 filed June 26, 1944, now Patent No. 2,496,880.

A rotary solenoid of this type comprises a magnet and an armature which is moved axially by the magnet, and is provided with means whereby the axial movement of the armature serves to impart rotary movement thereto. This means usually comprises a wall or plate fixed with relation to the magnet and a rotatable plate rigidly connected with the armature for movement therewith. The two plates are arranged in substantially parallel spaced relation and are provided with a plurality of pairs of arcuate inclined surfaces, the inclined surfaces of each pair being inclined in opposite directions and preferably constituting the base or bottom surfaces of arcuate grooves. Mounted in each pair of grooves is an anti-friction device, preferably a ball, and the arrangement of the inclined surfaces is such that the pressure of the rotatable plate exerted on the balls by the axial movement of the armature will cause the plate and, therefore, the armature to rotate and to impart movement to a shaft or other device connected with the armature for operation thereby. The magnet is deenergized at the end of each power transmitting movement of the armature. The armature is returned to its initial position by a spring and the magnet is again energized to impart a second power movement to the armature. When the deenergization and the reenergization of the magnet are automatically controlled the armature is caused to oscillate continuously, as shown in my application Serial Number 760,029, filed July 10, 1947, now Patent No. 2,501,950. In magnetically operated devices of this kind as heretofore constructed it has been customary to use a long coil spring for returning the armature to its initial position, that spring being connected at one end either directly or indirectly with the armature, off center, and being connected at its other end with a fixed part more or less remote from the armature, such as a part of the structure on which the device is mounted. Such a return spring, while satisfactory for many purposes, is limited in its operation and has certain undesirable features.

The main object of the invention is to provide a return spring of a relatively small, compact character which can be built into the electromagnetic device.

A further object of the invention is to provide such a spring which will have a range of opera-

2

tion much greater than the range of operation of springs heretofore employed for this purpose, thus permitting a longer rotary movement of the armature, upon each operation thereof, than has been heretofore possible.

A further object of the invention is to provide such a spring which will have substantially constant tension throughout its operation.

A further object of the invention is to provide such a spring which will be substantially frictionless.

A further object of the invention is to provide such a spring which can be adjusted to vary the tension thereof without removing it from the device on which it is mounted.

A further object of the invention is to provide such a return spring which will also function as a preloading spring to maintain the rotatable plate in firm engagement with the anti-friction elements when the magnet is deenergized.

A further object of the invention is to provide such a return spring which will positively limit the axial movement of the rotatable plate from the fixed plate when the magnet is deenergized.

Other objects of the invention may appear as the device is described in detail.

In the accompanying drawings Fig. 1 is a front elevation of a rotary solenoid embodying my invention, with the cover partly broken away; Fig. 2 is a section taken on the line 2-2 of Fig. 1; Fig. 3 is a detail section showing one pair of inclined surfaces; Fig. 4 is an elevation of the return spring; Fig. 5 is an edge view of the spring; Fig. 6 is an elevation of the plate with which the spring is connected; Fig. 7 is an edge view of the plate; Fig. 8 is a detail view showing the connection between one end of the spring and the plate; and Fig. 9 is a detail view of a portion of a modified form of shaft to which the spring is connected.

In these drawings I have illustrated one embodiment of my invention and have shown the same as embodied in a rotary solenoid of a construction similar to the rotary solenoid shown and described in my application filed of even date herewith, Serial Number 27,795. It is to be understood however that the spring may take various forms and may be applied to electromagnetic devices of various kinds, without departing from the spirit of the invention.

In the particular embodiment here illustrated the electromagnetic device is shown as a rotary solenoid comprising a supporting structure or casing consisting of an outer cylindrical member 10, a rear end wall 11 rigidly connected with

55

and in the present instance mounted in the rear end of the cylindrical member with a pressed fit. Mounted in the forward portion of the cylindrical member 10 is a front wall or annular plate 12 which is rigid with the member 10. The rear end member 11 is provided with a bearing 13 in which a shaft 14 is mounted, the shaft in the present instance being capable of both rotary movement and axial movement. The back wall is provided with an inwardly extending part 15 constituting the core and the bearing extends through this core. The shaft extends forwardly beyond the core and an armature 16 is connected with the shaft for rotary and axial movement therewith, preferably by rigidly mounting it on the shaft. The armature is here shown as extending through the annular plate 12 and a short distance beyond the same. Rigidly secured to the armature for both rotary and axial movements therewith is a second plate 17 which projects radially beyond the armature and is arranged in parallel spaced relation to the fixed plate 12. The rotatable plates and the fixed plate are provided with a plurality of pairs of inclined surfaces, these surfaces in the present instance constituting the bottom walls of grooves 18 and 19 formed, respectively, in the rotatable plate 17 and the fixed plate 12. The surfaces of each pair of inclined surfaces are inclined in opposite directions and an anti-friction device, such as a ball 20, is arranged between the inclined surfaces of each pair. Arranged between the fixed plate 12 and the marginal portion of the back plate 11, and extending about the core and a portion of the armature, is a magnetizing element or coil 21 which energizes the magnet and imparts axial movement to the armature. When the magnet is deenergized the shallow ends of the two oppositely inclined surfaces of each pair are adjacent one to the other and the anti-friction element is between the shallow ends of the surfaces. When the magnet is energized the axial movement of the armature causes the rotatable plate 17 to press on the several anti-friction elements in such a manner that the rotatable plate is caused to rotate simultaneously with its axial movement, thereby imparting both rotary movement and axial movement to the armature and the shaft. In the present instance the back plate 11 is provided with sockets to receive screws 22 by which the device may be connected with a supporting structure. If desired a dust cover 23 may be removably mounted on the forward end of the cylindrical member 10 to enclose the armature and its associated parts.

The means for controlling the magnet circuit are not here shown but they may be of any suitable character which will open the circuit at the end of the rotation of the armature by the magnet and again close the circuit when the armature is returned to its initial position, such as the circuit breakers and closers shown in either of the above mentioned applications. It will be understood, of course, that a master switch is connected in the circuit to start and stop the operation of the solenoid and when the master switch is closed the armature will oscillate continuously and at high speed.

The return spring is shown at 24 as a spiral spring which is connected at its inner end with the shaft 14 and is connected at its outer end with an anchoring device which is fixed with relation to the magnet. In the present instance the spiral spring is conical in form, for a purpose which

will hereinafter appear. The inner end of the spring may be connected with the shaft 14 in any suitable manner. In the arrangement here shown the shaft is provided with a transverse notch 25 and the inner convolution 26 of the spring fits snugly about the shaft and has its inner end turned inwardly, as shown at 27, to extend into the notch 25 and thus firmly secure the end of the spring to the shaft for rotation therewith. The end walls of the notch 25 are preferably parallel and of a width approximating the width of the inner convolution of the spring so that the spring rotates with the shaft and the inner convolutions move axially with the shaft.

The outer end of the spring may be anchored in any suitable manner, as by a lug or projection connected with and extending from the magnet, with which the end of the outer convolution 31 is connected. In the particular construction here illustrated a plate 28, preferably of thin metal, is supported on or adjacent to the rear wall of the magnet, as by mounting it on the attaching screws 22. This plate is provided with an axial opening 29 through which the shaft extends and which is of a diameter substantially greater than the diameter of the shaft. The anchoring plate 28 is provided at the edge of the opening 29 with a series of lugs 30. In the present instance these lugs are integral with the plate and are arranged in an annular series about the opening 29. They may be formed in any suitable manner, as by a stamping operation on a flat plate to form thereon inwardly extending radial lugs which are then bent outwardly to the positions shown in Fig. 7. The diameter of the opening approximates the over all diameter of the spiral spring so that when the spring is mounted on the shaft the outer convolution 31 thereof lies within the series of lugs and will have contact with at least a part of those lugs. As best shown in Fig. 4 the end of the outer convolution extends beneath and beyond one of the lugs and in contact with the inner surface of that lug and is provided on that part thereof which extends beyond the lug with a part 32 adapted to engage the adjacent edge of the lug and thus hold the end of the spring against rearward movement, that is prevent it from moving when the inner convolutions are rotated to place the spring under tension. The part 32 may be of any suitable character but it is here shown as a rearwardly extending finger struck from the end portion of the outer convolution and arranged with its rear end in engagement with the adjacent edge of the lug. Preferably the forward edge of the lug 30 is recessed to receive the rear end of the finger 32 and thus prevent the relative lateral displacement of the finger and of the end portion of the outer convolution. As will be noted particularly in Figs. 7 and 8 both sides of each lug are provided with curved recesses 33, and the end of the finger 32 is curved to fit in the recess of any lug.

While I have shown an annular series of lugs this is not essential and a shorter series of lugs or a single lug may be employed for anchoring the outer end of the spring. By the use of a series of lugs the outer convolutions of the spring may be adjusted to vary the tension of the spring. The finger 32 being resilient may be depressed and moved either forwardly or rearwardly beneath an adjacent lug and brought into operative engagement with another lug, thus tightening or loosening the outer convolution. The annular series of lugs on the anchor plate being in contact with or close to the outer convolution of the

spring retain that convolution and the adjacent convolutions substantially concentric with the axis of rotation of the shaft, thereby eliminating friction between those convolutions. Due to the connection of the end of the outer convolution with the fixed support on the outer side of and close to the outer convolution the winding of the spring by the shaft to place the spring under tension does not tend to laterally displace the spring or to press the convolutions on one side of the shaft into engagement one with the other, as usually results when the end of the outer convolution is anchored at a point spaced a substantial distance from the spring. As a result there is very little frictional contact between the convolutions of this spring. The outer convolution has contact with the adjacent convolution but in the operation of the device these two convolutions have very little relative movement. The inner-most convolution also has some contact with the adjacent convolution but the rotation of the shaft to place the spring under tension does not draw the other convolutions into engagement one with the other sufficiently to offer any material resistance to the contraction or expansion of the spring. It will be obvious, of course, that the connection between the spring and the shaft is such that the rotation of the shaft by the armature will wind the spring and place the same under tension and upon the deenergization of the magnet the spring will rotate the shaft and thus return the armature and the anti-friction elements to their initial positions. Therefore, it will be apparent from the character of the spring that the armature can have a very long range of rotary movement, as the only limitation of that movement would be the complete winding of the spring, and the spring is of such a size as to permit of relatively long movement. One of the objectionable features to the old type of return spring was that it definitely limited the distance to which the armature could be rotated without moving the point at which the spring is connected with the armature across center. The present spring is free from any such limitation. Not only is the spring substantially frictionless but it also has substantially constant tension. Due to the spiral winding and arrangement of this spring the resistance to the operative movement of the shaft increases very slightly as the shaft approaches the end of its movement. In the old type of return spring there is a very substantial increase in tension before the armature has completed its movement. The spring can be adjusted to increase or decrease the tension thereof very easily without removing the spring from the device, it being only necessary to detach the device from its supporting structure so as to gain access to the rear side thereof. The inner convolutions of the spring being connected with the shaft for axial movement therewith while the outer convolution is held against axial movement, it will be apparent that the axial movement of the shaft displaces the inner convolutions axially with relation to the outer convolutions and the spring thus yieldably resists the axial movement of the shaft. As a result the rotatable plate 17 is at all times held in firm engagement with the anti-friction device and there is no opportunity for these anti-friction devices to become displaced during the return movement of the armature after deenergization. Such displacement of the anti-friction elements would leave them in improper positions for operation upon the next energization of the magnet. When the anti-friction

devices are preloaded in the manner described they are not subject to displacement. Further the inner convolutions of the spring are so arranged with relation to the shaft that when the shaft is in its foremost position, that is the position to which it moves when the magnet is deenergized, these inner convolutions will engage a part fixed with relation to the magnet, in the present instance the end of the bearing 13, thereby limiting the forward axial movement of the shaft, and avoiding any possibility of the rotary plate 17 being at any time moved to a position with relation to the fixed plate 12 which would permit the escape of the anti-friction elements.

In Fig. 9 I have shown a slightly different arrangement of the notch in the shaft which is desirable when a ratchet wheel or the like is to be secured to the shaft. As there shown the shaft 14' is provided at its forward end with a reduced portion or axial stud 34 on which the ratchet wheel or other device may be mounted and the notch 25' is formed at the forward end of the body of the shaft and the ratchet wheel or other device mounted on the stud 34 serves to close the outer end of the recess.

While I have shown and described one embodiment of my invention I wish it to be understood that I do not desire to be limited to the details thereof as various modifications may occur to a person skilled in the art.

Having now fully described my invention what I claim as new and desire to secure by Letters Patent is:

1. A magnetically operated device comprising an electromagnet, an armature movable axially by said magnet, a plate fixed with relation to said magnet, a rotatable plate rigid with said armature and supported in parallel spaced relation to the first mentioned plate, said plates having a plurality of pairs of opposed inclined surfaces, anti-friction elements between the surfaces of the respective pairs of inclined surfaces, said surfaces being so arranged that the axial movement of said armature by said magnet will impart rotary movement to said armature, a shaft connected with said armature for rotary movement and axial movement thereby, and a single spring connected at one end with a fixed part of said device and connected at its other end with said shaft to return said armature to its initial position when said magnet is deenergized and to urge said shaft in a direction to retain said rotatable plate in firm contact with said anti-friction elements when said magnet is deenergized.

2. A magnetically operated device comprising an electromagnet, an armature movable axially by said magnet, a plate fixed with relation to said magnet, a rotatable plate rigid with said armature and supported in parallel spaced relation to the first mentioned plate, said plates having a plurality of pairs of opposed inclined surfaces, anti-friction elements between the surfaces of the respective pairs of inclined surfaces, said surfaces being so arranged that the axial movement of said armature by said magnet will impart rotary movement to said armature, a shaft connected with said armature for rotary movement and axial movement thereby, a spiral spring wound about said shaft in superposed convolutions, having its inner end connected with the shaft for rotary movement and for axial movement therewith, means for anchoring the outer end of said spring at a point fixed with relation to said magnet, the arrangement being such that the rotation of said shaft by said armature will place said

spring under tension and upon the deenergizing of said magnet said spring will return said armature to its initial position and will exert axial pressure on said shaft to retain said rotatable plate in firm contact with said anti-friction elements.

3. A magnetically operated device comprising an electromagnet, an armature movable axially by said magnet, a plate fixed with relation to said magnet, a rotatable plate rigid with said armature and supported in parallel spaced relation to the first mentioned plate, said plates having a plurality of pairs of opposed inclined surfaces, anti-friction elements between the surfaces of the respective pairs of inclined surfaces, said surfaces being so arranged that the axial movement of said armature by said magnet will impart rotary movement to said armature, a shaft connected with said armature for rotary movement and axial movement thereby, a plate fixed with relation to said magnet at that end thereof opposite said armature and having an annular series of lugs extending lengthwise of said shaft, a conical spiral spring mounted about said shaft with the outer convolution thereof within said series of lugs, means for connecting said outer convolution with one of said lugs, means for connecting the inner convolution of said spring with said shaft

for both axial and rotary movements therewith, a part of the convolutions of said spring being arranged to engage a part fixed with relation to said magnet and limit the axial movement of said shaft when said magnet is deenergized, whereby said spring serves to return said armature to its initial position, to yieldably urge said shaft in one axial direction and to limit the axial movement of said shaft in the opposite direction.

GEORGE H. LELAND.

#### REFERENCES CITED

The following references are of record in the file of this patent:

#### UNITED STATES PATENTS

Number	Name	Date
1,138,733	Earll -----	May 11, 1915
1,292,267	Dawson et al. -----	Jan. 21, 1919
1,802,459	Caruso -----	Apr. 28, 1931
2,009,964	Mottlan -----	July 30, 1935
2,110,033	Bostick -----	Mar. 1, 1938
2,227,328	Steiss -----	Dec. 31, 1940
2,446,138	Lambert -----	July 27, 1948

#### FOREIGN PATENTS

Number	Country	Date
659,975	Germany -----	Apr. 21, 1938