



(11) **EP 2 494 877 B2**

(12) **NEW EUROPEAN PATENT SPECIFICATION**  
After opposition procedure

(45) Date of publication and mention  
of the opposition decision:  
**21.03.2018 Bulletin 2018/12**

(51) Int Cl.:  
**A24D 3/04** <sup>(2006.01)</sup> **A24D 3/06** <sup>(2006.01)</sup>  
**A24D 3/14** <sup>(2006.01)</sup>

(45) Mention of the grant of the patent:  
**02.07.2014 Bulletin 2014/27**

(21) Application number: **12168428.6**

(22) Date of filing: **14.08.2008**

---

(54) **Multi-component filter for a smoking article**

Mehrkomponentenfilter für einen Rauchtartikel

Filtre multicomposants pour article à fumer

---

(84) Designated Contracting States:  
**AT BE BG CH CY CZ DE DK EE ES FI FR GB GR  
HR HU IE IS IT LI LT LU LV MC MT NL NO PL PT  
RO SE SI SK TR**  
Designated Extension States:  
**RS**

(30) Priority: **17.08.2007 EP 07253246**

(43) Date of publication of application:  
**05.09.2012 Bulletin 2012/36**

(62) Document number(s) of the earlier application(s) in  
accordance with Art. 76 EPC:  
**08827853.6 / 2 175 749**

(73) Proprietor: **Philip Morris Products S.A.**  
**2000 Neuchâtel (CH)**

(72) Inventors:  
• **Besso, Clement**  
**2000 Neuchatel (CH)**

• **Jordil, Yves**  
**74500 Lugrin (FR)**  
• **Kuersteiner, Charles**  
**1008 Jouxkens-Mezery (CH)**

(74) Representative: **Taylor, Gillian Claire**  
**Reddie & Grose LLP**  
**The White Chapel Building**  
**10 Whitechapel High Street**  
**London E1 8QS (GB)**

(56) References cited:  
**EP-A2- 0 232 166** **WO-A-01/80671**  
**WO-A-02/069745** **WO-A-2006/090290**  
**GE-B- P20 043 350** **JP-U- H02 127 194**  
**US-A- 2 948 282** **US-A- 4 281 671**  
**US-A1- 2002 062 833**

**EP 2 494 877 B2**

**Description**

**[0001]** The present invention relates to a multi-component filter for a smoking article and to a smoking article comprising such a multi-component filter.

**[0002]** Filter cigarettes typically comprise a rod of tobacco cut filler surrounded by a paper wrapper and a cylindrical filter aligned in end-to-end relationship with the wrapped tobacco rod and attached thereto by tipping paper. Ventilation in the form of circumferential perforations is commonly provided at a location along the filter, to mix the mainstream smoke produced during combustion of the wrapped tobacco rod with ambient air.

**[0003]** In conventional filter cigarettes, the filter usually consists of a plug of cellulose acetate tow wrapped in porous plug wrap. However, filter cigarettes with multi-component filters that comprise two or more segments of filtration material for the removal of particulate and gaseous components of the mainstream smoke are also known. To enhance the flavour of the mainstream smoke, it is known to provide filter cigarettes with filters that include flavourants. In particular, it has been proposed to include flavourants in the form of plant material, such as leaves, seeds or roots, from one or more aromatic plants. In one known example, a filter cigarette is proposed with a multi-component filter having a flavour release segment containing a mixture of plant materials, including liquorice plant material, ginger root and shredded peppermint leaf.

**[0004]** WO 2006/090290 A1 describes a smoking article in which tobacco beads are provided in the filter or in the tobacco rod. The tobacco beads may include flavourants in addition to tobacco particulates. In one arrangement, the filter includes a sorbent, which removes at least one constituent from mainstream tobacco smoke passing through the filter, and downstream tobacco beads which compensate for taste lost to the sorbent.

**[0005]** Japanese utility model H2-127194 discloses a multi-component filter for a smoking article wherein herbs in dried, pulverised form is filled in between a front and back filter material.

**[0006]** It would be desirable to provide a multi-component filter for a smoking article that, in use, provides improved flavour enhancement, and in particular improved mint and menthol flavour delivery to mainstream smoke as it is drawn from a rod of smokable material through the filter by a consumer. Furthermore, it would be desirable to provide a multi-component filter for a smoking article comprising a flavour release segment that minimises loss of flavour during storage.

**[0007]** According to the present invention there is provided a multi-component filter for a smoking article comprising: a mouth end segment; and a flavour release segment upstream of the mouth end segment, wherein the flavour release segment comprises a plug of aromatic non-tobacco herb leaf coated with glycerol triacetate.

**[0008]** According to the invention there is also provided a smoking article comprising a wrapped rod of smokable material and a multi-component filter according to the present invention attached to the rod of smokable material, preferably by tipping paper. Preferably, the smoking article is a filter cigarette.

**[0009]** Throughout the specification, the terms "upstream" and "downstream" are used to describe the relative positions of segments of the multi-component filter of the invention in relation to the direction of the mainstream smoke drawn from a rod of smokable material through the multi-component filter during use. For example, in the filter of the present invention the flavour release segment is upstream of the mouth end segment, which means that mainstream smoke is drawn first through the flavour release segment and then through the mouth end segment.

**[0010]** The term "filter plasticiser" refers to any compound suitable for use as a plasticiser in a conventional fibrous cigarette filter plug. In conventional fibrous filter plugs, the role of a filter plasticiser is to bind together the fibres of the plug so that the rigidity of the plug, and therefore its resistance to compression, is increased. The plasticiser is typically a solvent for the fibre material and acts by softening the outer surfaces of the fibres such that they adhere to each other. Glycerol triacetate is commonly used as the filter plasticiser for a cellulose acetate tow.

**[0011]** The filter plasticiser used in the present invention is glycerol triacetate.

**[0012]** The term "plant leaf" is used to denote a material consisting of the leaves of a plant, which have preferably been cut or shredded to provide a particulate material. The term "herb leaf" is used to denote leaves from an herbaceous plant. An "herbaceous plant" is an aromatic plant without woody tissue, the leaves of which are used for medicinal, culinary or aromatic purposes and are capable of releasing flavour into mainstream smoke drawn through the multi-component filter. The flavour release segment may comprise herb leaf from one or more perennial or annual herbaceous plants. For example, the flavour release segment may comprise herb leaf from herbaceous plants including, but not limited to, peppermint, lemon balm, basil cinnamon, lemon basil, chive, coriander, basil, lavender, sage, tea, thyme and carvi.

**[0013]** The flavour release segment may include any herb leaf that is capable of releasing flavour into mainstream smoke drawn through the multi-component filter. The herb leaf is non-tobacco herb leaf. The flavour release segment may include leaf from one or more plants. In preferred embodiments, the flavour released from the herb leaf is provided by volatile compounds, such as oils, contained therein, which are volatilised during smoking. The mainstream smoke enriched with the volatile oils from the herb leaf flows downstream through the mouth end segment of the multi-component filter into the consumer's mouth.

**[0014]** Prior to smoking, the volatile oils remain trapped within the herb leaf. This advantageously ensures that loss

of flavour during storage of multi-component filters and smoking articles according to the present invention is minimised, and so maximises flavour release into the mainstream smoke during smoking.

[0015] Preferably, the herb leaf in the flavour release segment is shredded, cut or otherwise reduced in size. More preferably, the herb leaf has a cut width of between about 0.25 mm and about 3 mm. Most preferably, the herb leaf has a cut width of between about 1 mm and about 2 mm.

[0016] Preferably, the herb leaf is dried to a moisture content of between about 8 % and about 10%.

[0017] The flavour release segment comprises a plug of plant leaf, preferably compressed plant leaf, coated with glycerol triacetate, a filter plasticiser. The plug preferably does not comprise any other materials. The filter plasticiser may be applied to the plant leaf before, or after the plug is formed. In smoking articles according to the second aspect of the invention, the flavour release segment is preferably between about 3 mm and about 12 mm in length.

[0018] The amount of glycerol triacetate is preferably between about 0.5 % and about 1.5 % by weight of the herb leaf. In such smoking articles a much lower level of glycerol triacetate is required than in smoking articles in which the peppermint leaf is distributed in a plug of fibrous filtration material, since the glycerol triacetate is required only for flavour enhancement and not to stiffen the filter plug. In particularly preferred embodiments of the present invention, the herb leaf in the flavour release segment comprises peppermint leaf. Preferably, the oil content of the peppermint leaf is at least about 0.6 % by weight. The inclusion of peppermint leaf in the flavour release segment of multi-component filters according to the present invention advantageously provides an improved way of imparting mint and menthol flavours to the mainstream smoke of a smoking article. Smoking articles according to the present invention with multi-component filters comprising peppermint leaf advantageously provide enhanced mint and menthol flavours compared to conventional menthol cigarettes. In particularly preferred embodiments of the invention, the herb leaf in the flavour release segment is peppermint leaf. It has surprisingly been found that the inclusion of peppermint leaf and glycerol triacetate in the flavour release segment of multi-component filters and smoking articles advantageously enhances the mint and menthol flavour provided by the release of menthol and other volatile oils from the peppermint leaf. This is illustrated, for example, by the results shown in Table 1, below.

[0019] Table 1 shows the quantities of particular flavour compounds released into the mainstream smoke from peppermint leaf in the flavour release segment of filter cigarettes (Samples 1 and 3) having the general construction shown in Figure 1. The flavour release segment consists of a plug of cellulose acetate tow with peppermint leaf and glycerol triacetate distributed therein. Table 1 also shows the quantities of the flavour compounds released from peppermint leaf in the flavour release segment of filter cigarettes (Samples 2 and 4) having the same construction as Samples 1 and 3, but in which the flavour release segment does not contain glycerol triacetate. Each of the samples contains 40 mg of peppermint leaf. Not all of the compounds released from the peppermint leaf are measured.

[0020] Each of the samples is smoked under ISO conditions and the smoke extracts obtained are analysed using a GC-MS single ion monitoring method in order to determine the levels of the volatile compounds in the smoke. A full scan analysis with a scan range from 30 to 400 m/z (anion mass to charge ratio) is performed.

[0021] As can be seen from Table 1, the combination of glycerol triacetate and peppermint leaf in the flavour release segment of filter cigarettes results in increased levels of flavour compounds being released from the peppermint leaf into the mainstream smoke during smoking compared to the filter cigarettes not according to the invention, in which the flavour release segment does not contain glycerol triacetate.

Table 1

	Sample 1	Sample 2	Sample 3	Sample 4
Tar, mg/cigarette	1	1	6	6
Glycerol triacetate content of flavour release segment, %	5	0	5	0
Amount of menthol released into mainstream smoke during smoking, $\mu\text{g}/\text{cigarette}$	0.70	0.25	3.63	1.79
Amount of menthone released into mainstream smoke during smoking, $\mu\text{g}/\text{cigarette}$	0.45	0.36	1.19	0.87
Amount of menthyl acetate released into mainstream smoke during smoking, $\mu\text{g}/\text{cigarette}$	Nd	nd	0.187	0.052
Amount of neomenthol released into mainstream smoke during smoking, $\mu\text{g}/\text{cigarette}$	0.050	0.018	0.254	0.124
Amount of $\alpha$ -pinene released into mainstream smoke during smoking, $\mu\text{g}/\text{cigarette}$	Nd	nd	0.032	0.030

(continued)

	Sample 1	Sample 2	Sample 3	Sample 4
Amount of $\beta$ -pinene released into mainstream smoke during smoking, $\mu\text{g}/\text{cigarette}$	Nd	nd	0.050	0.049
(nd = not determined)				

**[0022]** During smoking of a smoking article comprising a multi-component filter according to the invention in which the filter plasticiser is glycerol triacetate, acetic acid and glycerine are released in the flavour release segment of the filter as a result of hydrolysis of the glycerol triacetate. Accordingly, the levels of acetic acid released in the filter during smoking are significantly higher than for a smoking article not according to the invention, as illustrated by the results shown in Table 2, below. Table 2 gives the dimensions and properties of a filter cigarette (Sample 5) having the general construction shown in Figure 1. The mouth end segment of the filter cigarette consists of a plug of cellulose acetate tow and the flavour release segment consists of a plug of cellulose acetate tow with peppermint leaf and glycerol triacetate distributed therein. Table 2 also gives the dimensions and properties of a filter cigarette (Sample 6) in which the flavour release segment does not contain glycerol triacetate.

**[0023]** As can be seen from Table 2, the combination of glycerol triacetate and peppermint leaf in the flavour release segment of the multi-component filter of a filter cigarette (Sample 5) results in a significantly increased level of acetic acid being released in the filter compared to the filter cigarette (Sample 6) in which only the mouth end segment contains glycerol triacetate.

Table 2

	Sample 5	Sample 6
Tar, mg/cigarette	6.1	6.2
Total RTD, mmH <sub>2</sub> O	93	92
Ventilation, %	35	36
Length of cigarette, mm	84.0	84.0
Length of mouth end segment, mm	15.0	15.0
Length of flavour release segment, mm	12.0	12.0
Filter RTD, mmH <sub>2</sub> O	92.7	91.2
Glycerol triacetate content of mouth segment, %	7.0	7.0
Glycerol triacetate content of flavour release segment, %	5.0	0.0
Peppermint leaves content, mg	40.0	40.0
Acetic acid concentration, ppm (based on cigarette weight = 920mg)	221	57

**[0024]** Preferably, the overall length of smoking articles according to the present invention is between about 70 mm and about 128 mm, more preferably about 84 mm.

**[0025]** Preferably, the external diameter of multi-component filters and smoking articles according to the present invention is between about 5 mm and 8.5 mm, more preferably about 7.9 mm.

**[0026]** Preferably, the overall length of multi-component filters according to the present invention is between about 18 mm and about 36 mm, more preferably about 27 mm.

**[0027]** Preferably, the length of each individual segment of multi-component filters according to the present invention is between about 5 mm and about 22 mm.

**[0028]** The mouth end segment of multi-component filters according to the present invention may, in some embodiments, advantageously prevent herb leaf from the flavour release segment reaching the mouth of the consumer during smoking. Preferably, the mouth end segment comprises filtration material. More preferably, the mouth end segment comprises filtration material that has substantially no particulate phase filtration efficiency or very low particulate phase filtration efficiency. The mouth end segment may, for example, comprise cellulosic material, such as cellulose acetate tow, or other suitable fibrous filtration material of low filtration efficiency.

**[0029]** Where the mouth end segment comprises filtration material, the length of the mouth end segment is preferably between about 3 mm and about 12 mm, more preferably between about 6 mm and about 8 mm.

**[0030]** Multi-component filters according to the present invention may further comprise a rod end segment upstream of the flavour release segment. Preferably, the rod end segment comprises fibrous filtration material. The rod end segment may, for example, comprise cellulosic material, such as cellulose acetate tow, or other suitable fibrous filtration materials such as paper. The inclusion of a rod end segment comprising filtration material advantageously provides additional filtration efficiency.

**[0031]** Alternatively or in addition, the rod end segment may comprise at least one sorbent capable of removing at least one gas phase constituent from mainstream smoke drawn through the filter. Preferably, the at least one sorbent is selected from the group consisting of activated carbon, active aluminium, zeolites, sepiolites, molecular sieves and silica gel.

**[0032]** The rod end segment may include one or more flavourants, preferably one or more liquid flavourants, to further enhance flavour delivery to the consumer during smoking.

**[0033]** For example, the rod end segment may comprise a plug of filtration material including one or more threads impregnated with liquid flavourant. The one or more threads may be made from cellulose acetate yarn, rayon, cotton, or any other hydrophilic textile or non-textile material capable of absorbing or adsorbing the liquid flavourant. The threads may be coloured, for example, to indicate the type of flavourant impregnated therein. If more than one thread is provided, the threads may be the same or different colours and may be impregnated with the same or different liquid flavourants. Preferably, the threads are between about 0.6 mm and about 2.0 mm in diameter, more preferably about 0.8 mm in diameter. Filter plugs comprising flavourant bearing threads suitable for use in rod end segments of multi-component filters according to the present invention, and methods and apparatuses for producing such plugs, are described in US Patents Nos. 4,281,671 and 7,074,170 and are available from the American Filtrona Company, Richmond, Virginia, USA.

**[0034]** Alternatively, the rod end segment may include a plurality of beads impregnated with liquid flavourant. The beads may be formed from, for example, a cellulosic material bonded with a polyvinyl acetate binder, or from tobacco powder bonded with microcrystalline cellulose. Beads suitable for use in rod end segments of multi-component filters according to the present invention are manufactured and sold under the brand Viscoppearls® by Rengo Co. Ltd., Japan. Methods and apparatuses for producing such beads are also described in Japanese Patent Application No. 10182842. The beads may be of the same or different diameters and colours. The colour of the beads may, for example, indicate the type of flavourant with which they are impregnated. Preferably, the beads are between about 0.2 mm and about 2 mm in diameter.

**[0035]** Liquid flavourants for use in the rod end segments of multi-component filters according to the present invention may include one or more flavour ingredients to create a certain flavour type and may be natural extracts, synthetic flavours, or a combination thereof. Liquid flavourants and flavour types that may be included in the rod end segment of multi-component filters according to the present invention include, but are not limited to, menthol, peppermint, spearmint, coffee, tea, spices (such as cinnamon, clove and ginger), cocoa, vanilla and fruit flavourants. In preferred embodiments of the present invention in which the herb leaf in flavour release segment is peppermint leaf, the rod end segment of the multi-component filter preferably comprises a liquid menthol flavourant. In such embodiments, the provision of a menthol flavourant in the rod end segment advantageously enhances the flavour released into mainstream smoke drawn through the filter during smoking and compliments the menthol and mint flavours released downstream into the mainstream smoke by the peppermint leaf in the flavour release segment.

**[0036]** The mouth end segment may comprise at least one flavourant, such as those previously described above for the rod end segment. Preferably, if a flavourant is provided, the mouth end segment includes one or more threads impregnated with liquid flavourant.

**[0037]** Multi-component filters according to the present invention may include mouth end segments comprising at least one flavourant or rod end segments comprising at least one flavourant or mouth end segments comprising at least one flavourant and rod end segments comprising at least one flavourant. Where the mouth end segment and the rod end segment comprise at least one flavourant, the at least one flavourant in the mouth end segment may be the same as or different to the at least one flavourant in the rod end segment.

**[0038]** In use, as mainstream smoke is drawn from a rod of smokable material through the multi-component filter, flavour is released into the mainstream smoke from the herb leaf in the flavour release segment. In embodiments of the present invention in which at least one flavourant is provided in the rod end segment, flavour is also released upstream of the flavour release segment as previously described above. In embodiments of the present invention in which at least one flavourant is alternatively or additionally provided in the mouth end segment, flavour is also released downstream of the flavour release segment. Multi-component filters according to the present invention may, therefore, provide dual or triple flavour enhancement to mainstream smoke drawn through the filter during smoking.

**[0039]** Multi-component filters according to the present invention may be produced by forming separate continuous rods comprising multiple units of each individual segment of the multi-component filter and then combining these separate rods in a known manner in one or more stages to form a continuous filter rod comprising multiple units of the multi-component filter. The continuous filter rod may then be subsequently severed at regular intervals by a cutting mechanism to yield a succession of discrete multi-component filters according to the invention.

[0040] Preferably, smoking articles according to the present invention comprise a wrapped rod of tobacco cut filler.

[0041] Preferably, smoking articles according to the present invention have a total nicotine free dry particulate matter (NFDPM) or "tar" delivery of up to about 10 mg. More preferably, the "tar delivery" is between 1 mg and 10 mg and more preferably about 6 mg.

5 [0042] Smoking articles according to the present invention may be packaged in containers, for example in soft packs or hinge-lid packs, with an inner liner coated with one or more flavourants.

[0043] In some embodiments, multi-component filters according to the present invention further comprise a second flavour release segment between the mouth end segment and the flavour release segment previously described. The inclusion of a second flavour release segment further enhances flavour delivery to the consumer during smoking.

10 [0044] Preferably, the second flavour release segment comprises tobacco leaf. The tobacco leaf may be shredded, cut, or otherwise reduced in size. Preferably, the tobacco leaf is finely cut and more preferably, the tobacco leaf has a cut width of about 0.4 mm.

[0045] Preferably the tobacco leaf in the second flavour release segment is dried. Preferably the moisture content of the tobacco leaf is about 15% or less by weight.

15 [0046] Preferably, the length of the second flavour release segment is between about 6 mm and about 12 mm, more preferably between about 6 mm and about 10 mm.

[0047] The second flavour release segment may include tobacco leaf to which casing comprising, for example, sugars or humectants has been applied.

20 [0048] The invention will be further described, by way of example only, with reference to the accompanying drawings, in which:

Figures 1 to 3 show side views of three exemplary filter cigarettes comprising multi-component filters having a construction that does not form part of the present invention;

25 Figures 4 to 7 show schematic longitudinal cross sections of four exemplary filter cigarettes comprising multi-component filters having a construction that does not form part of the present invention;

Figure 8 shows a side view of a filter cigarette comprising a multi-component filter according to an embodiment of the present invention; and

Figure 9 shows a side view of a filter cigarette comprising a multi-component filter according to a further embodiment of the present invention.

30 [0049] The filter cigarettes shown in Figures 1 to 9 have several components in common and these components have been given the same reference numerals. In each of the side views, portions have been broken away to illustrate interior details of the multi-component filter.

35 [0050] Each filter cigarette generally comprises an elongate, cylindrical wrapped tobacco rod 2 attached at one end to an axially aligned, elongate, cylindrical, multi-component filter 4. The wrapped tobacco rod 2 and the multi-component filter 4 are joined in a conventional manner by tipping paper 6, which circumscribes the entire length of the multi-component filter and an adjacent portion of the wrapped tobacco rod 2. To ventilate mainstream smoke produced during combustion of the wrapped tobacco rod 4 with ambient air, a plurality of annular perforations 8 are provided through the tipping paper 6 at a location along the multi-component filter 4.

40 [0051] The multi-component filter 4 of the filter cigarette 10 according to the first embodiment of the invention shown in Figure 1 includes two segments in abutting end-to-end relationship: a mouth end segment 12, distant from the wrapped tobacco rod 2; and a flavour release segment 14, located upstream of the mouth end segment 12 and adjacent to and abutting the wrapped tobacco rod 2. The mouth end segment 12 comprises a plug of cellulose acetate tow of low filtration efficiency plasticised with glycerol triacetate. The flavour release segment 14 comprises a plug of cellulose acetate tow with dried peppermint leaf having a cut width of between 1 mm and 2 mm substantially evenly distributed through it. The plug of cellulose acetate tow includes 5 % by weight of glycerol triacetate plasticiser.

45 [0052] The multi-component filter 4 of the filter cigarette 20 shown in Figure 2 is of similar construction to the multi-component filter 4 of the filter cigarette 10 shown in Figure 1 and described above. However, the mouth end segment 12 of the filter cigarette 20 shown in Figure 2 further comprises a central cotton thread 22 loaded with menthol that extends axially through the plug of cellulose acetate tow, parallel to the longitudinal axis of the filter cigarette 20.

50 [0053] The filter cigarette 30 shown in Figure 3 has a multi-component filter 4 that includes three segments in abutting end-to-end relationship: a mouth end segment 12, distant from the tobacco rod 2; a flavour release segment 14 located upstream of the mouth end segment; and a rod end segment 32, located upstream of the flavour release segment 14 and adjacent to and abutting the wrapped tobacco rod 2. The mouth end segment 12 and the flavour release segment 14 are of the same construction as those previously described for the filter cigarette 10 shown in Figure 1.

55 [0054] The rod end segment 32 comprises a plug of cellulose acetate tow of medium to high filtration efficiency which, in use, partially filters out particulate phase components of the mainstream smoke.

[0055] The multi-component filter 4 of the filter cigarette 40 shown in Figure 4 is of similar construction to the multi-

component filter 4 of the filter cigarette 30 shown in Figure 3 and described above. However, the mouth end segment 12 of the filter cigarette 40 shown in Figure 4 further comprises a central cotton thread 22 loaded with menthol that extends axially through the plug of cellulose acetate tow, parallel to the longitudinal axis of the filter cigarette 40.

**[0056]** The multi-component filter 4 of the filter cigarette 50 shown in Figure 5 is also of similar construction to the multi-component filter 4 of the filter cigarette 30 shown in Figure 3 and described above. However, the rod end segment 32 of the multi-component filter 4 of the filter cigarette 50 shown in Figure 5 comprises a central cotton thread 52 loaded with menthol that extends axially through the plug of cellulose acetate tow, parallel to the longitudinal axis of the filter cigarette 50.

**[0057]** The multi-component filter 4 of the filter cigarette 60 shown in Figure 6 is once again of similar construction to the multi-component filter 4 of the filter cigarette 30 shown in Figure 3 and described above. However, both the rod end segment 32 and the mouth end segment 12 of the multi-component filter 4 of the filter cigarette 60 shown in Figure 6 comprise a central cotton thread 22, 52 loaded with menthol that extends axially through the plug of cellulose acetate tow, parallel to the longitudinal axis of the filter cigarette 60.

**[0058]** The multi-component filter 4 of the filter cigarette 70 shown in Figure 7 is of similar construction to the multi-component filter 4 of the filter cigarette 50 shown in Figure 5 and described above. However, the rod end segment 32 of the multi-component filter 4 of the filter cigarette 70 shown in Figure 7 comprises a plurality of Viscopearls® loaded with menthol, in place of the central cotton thread 52.

**[0059]** The filter cigarette 80 shown in Figure 8 has a multi-component filter 4 similar in construction to the multi-component filters 4 of the filter cigarettes 30, 40, 50, 60 shown in Figures 3 to 6, which includes three segments in abutting end-to-end relationship: a mouth end segment 12, distant from the tobacco rod 2; a flavour release segment 14 located upstream of the mouth end segment; and a rod end segment 32, located upstream of the flavour release segment 14 and adjacent to and abutting the wrapped tobacco rod 2. The mouth end segment 12 and the rod end segment 14 are of the same construction as those previously described for the filter cigarettes 30, 40, 50, 60 shown in Figures 3 to 6. The flavour release segment 14 comprises a plug of fine cut peppermint leaf, which is coated with glycerol triacetate and compressed, in place of the plug of cellulose acetate tow with peppermint distributed through it. The amount of glycerol triacetate is between about 0.5 % and 1.5 % by weight of the peppermint leaf.

**[0060]** It will be appreciated that either or both of the mouth end segment 12 and the rod end segment 42 of the filter cigarette 80 shown in Figure 8 may include a flavourant, as previously described above for the filter cigarettes 30, 40, 50, 60 shown in Figures 3 to 6.

**[0061]** The filter cigarette 90 shown in Figure 9 has a multi-component filter 4 that includes four segments in abutting end-to-end relationship: a mouth end segment 12, distant from the tobacco rod 2; a first flavour release segment 92 located upstream of the mouth end segment, a second flavour release segment 14 located upstream of the first flavour release segment; and a rod end segment 32, located upstream of the second flavour release segment 14 and adjacent to and abutting the wrapped tobacco rod 2. The mouth end segment 12, the second flavour release segment 14 and the rod end segment 32 are of the same construction as the mouth end segment, the flavour release segment and the rod end segment previously described for the filter cigarettes 30, 40, 50, 60, 70 shown in Figures 3 to 7. The second flavour release segment 92 comprises a plug of densely packed fine cut tobacco.

**[0062]** To form the filter cigarettes 10, 20, 30, 40, 50, 60, 70, 80, 90 shown in Figures 1 to 9, the multi-component filters 4 are produced and then joined to the wrapped tobacco rods 2, which are produced in a conventional manner, by the tipping paper 6 using known filter cigarette making equipment.

**[0063]** To produce each multi-component filter 4, separate continuous rods comprising multiple units of each segment 12, 14, 32, 92 of the multi-component filter 4 are produced in a known manner and then combined to form a continuous filter rod comprising multiple units of the multi-component filter 4. The continuous filter rod is then severed at regular intervals by a cutting mechanism to yield a succession of discrete multi-component filters.

## Claims

1. A multi-component filter (4) for a smoking article comprising:

a mouth end segment (12); and  
 a flavour release segment (14) upstream of the mouth end segment (12),  
 wherein the flavour release segment (14) comprises a plug of aromatic non-tobacco herb leaf coated with glycerol triacetate.

2. A multi-component filter (4) according to claim 1 wherein the amount of glycerol triacetate is between 0.5% and 1.5% by weight of the herb leaf.

3. A multi-component filter (4) according to claim 1 or 2 wherein the herb leaf in the flavour release segment (14) is compressed herb leaf.
- 5 4. A multi-component filter (4) according to any preceding claim wherein the herb leaf (14) comprises peppermint leaf.
5. A multi-component filter (4) according to any preceding claim further comprising a rod end segment (32) upstream of the flavour release segment (14).
- 10 6. A multi-component filter according to any preceding claim further comprising a second flavour release segment between the mouth end segment and the flavour release segment.
7. A multi-component filter (4) according to any preceding claim wherein the mouth end segment (12) comprises filtration material.
- 15 8. A multi-component filter (4) according to any preceding claim wherein the mouth end segment (12) comprises at least one liquid flavourant.
9. A smoking article (10)(20)(30)(40)(50)(60)(70)(80) comprising:
- 20 a wrapped rod of smokable material (2); and  
a multi-component filter (4) according to any preceding claim attached to the rod of smokable material (2) by tipping paper (6).

25 **Patentansprüche**

1. Mehrkomponentenfilter (4) für einen Rauchtartikel, das Folgendes umfasst:
- 30 ein Mundendeselement (12); und  
ein aromafreisetzendes Segment (14) stromaufwärts von dem Mundendeselement (12),  
wobei das aromafreisetzende Segment (14) einen Pfropfen aus mit Glyceroltriacetat beschichtetem aromatischem Nicht-Tabak-Krautblatt umfasst.
- 35 2. Mehrkomponentenfilter (4) nach Anspruch 1, wobei die Menge an Glyceroltriacetat zwischen 0,5 und 1,5 Gew.-% des Krautblatts liegt.
3. Mehrkomponentenfilter (4) nach Anspruch 1 oder 2, wobei das Krautblatt in dem aromafreisetzenden Segment (14) gepresstes Krautblatt ist.
- 40 4. Mehrkomponentenfilter (4) nach einem vorherigen Anspruch, wobei das Krautblatt (14) Pfefferminzblatt umfasst.
5. Mehrkomponentenfilter (4) nach einem vorherigen Anspruch, das ferner ein Stabendeselement (32) stromaufwärts von dem aromafreisetzenden Segment (14) umfasst.
- 45 6. Mehrkomponentenfilter nach einem vorherigen Anspruch, das ferner ein zweites aromafreisetzendes Segment zwischen dem Mundendeselement und dem aromafreisetzenden Segment umfasst.
7. Mehrkomponentenfilter (4) nach einem vorherigen Anspruch, wobei das Mundendeselement (12) Filtrationsmaterial umfasst.
- 50 8. Mehrkomponentenfilter (4) nach einem vorherigen Anspruch, wobei das Mundendeselement (12) wenigstens einen flüssigen Aromastoff umfasst.
9. Rauchtartikel (10) (20) (30) (40) (50) (60) (70) (80), der Folgendes umfasst:
- 55 einen umwickelten Stab aus rauchbarem Material (2); und  
ein Mehrkomponentenfilter (4) nach einem der vorherigen Ansprüche, das mit Tipping-Papier (6) an dem Stab aus rauchbarem Material (2) angebracht ist.

**Revendications**

1. Filtre multicomposants (4) pour article à fumer comprenant :

5 un segment d'embout buccal (12) ; et  
un segment de libération d'arôme (14) en amont du segment d'embout buccal (12) ;  
dans lequel le segment de libération d'arôme (14) comprend un bouchon de feuille végétale aromatique non  
de tabac revêtue de triacétate de glycérol.

10 2. Filtre multicomposants (4) selon la revendication 1 dans lequel la quantité de triacétate de glycérol est comprise  
entre 0,5% et 1,5% en poids de la feuille végétale.

15 3. Filtre multicomposants (4) selon la revendication 1 ou 2 dans lequel la feuille végétale dans le segment de libération  
d'arôme (14) est une feuille végétale compressée.

4. Filtre multicomposants (4) selon l'une quelconque des revendications précédentes dans lequel la feuille végétale  
(14) comprend une feuille de menthe poivrée.

20 5. Filtre multicomposants (4) selon l'une quelconque des revendications précédentes comprenant en outre un segment  
final de bâtonnet (32) en amont du segment de libération d'arôme (14).

6. Filtre multicomposants (4) selon l'une quelconque des revendications précédentes comprenant en outre un second  
segment de libération d'arôme entre le segment d'embout buccal et le segment de libération d'arôme.

25 7. Filtre multicomposants (4) selon l'une quelconque des revendications précédentes dans lequel le segment d'embout  
buccal (12) comprend une substance de filtration.

30 8. Filtre multicomposants (4) selon l'une quelconque des revendications précédentes dans lequel le segment d'embout  
buccal (12) comprend au moins un aromatisant liquide.

9. Article à fumer (10) (20) (30) (40) (50) (60) (70) (80) comprenant :

35 un bâtonnet enveloppé d'une substance fumable (2) ; et  
un filtre multicomposants (4) selon l'une quelconque des revendications précédentes attaché au bâtonnet de  
substance fumable (2) par un papier de manchette (6).

40

45

50

55

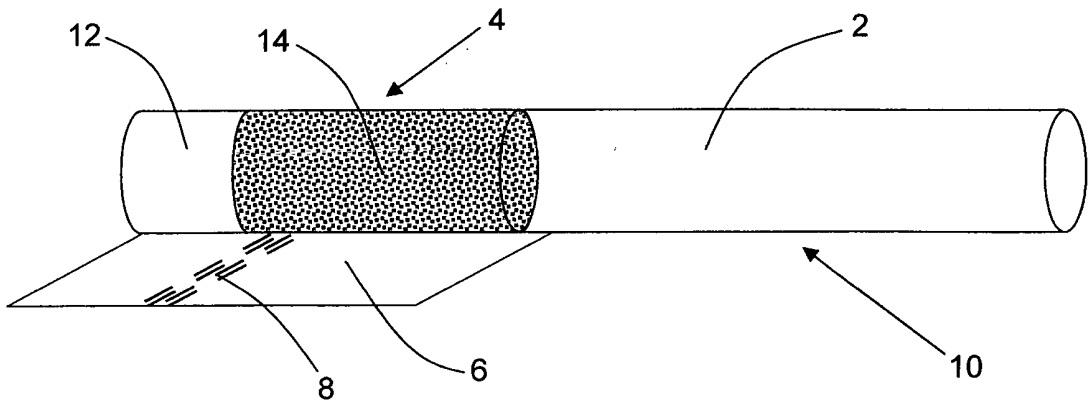

Figure 1

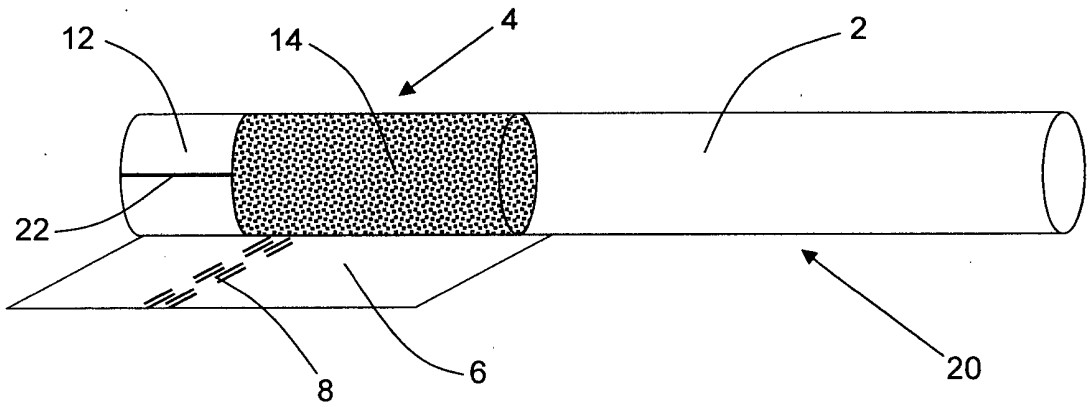

Figure 2

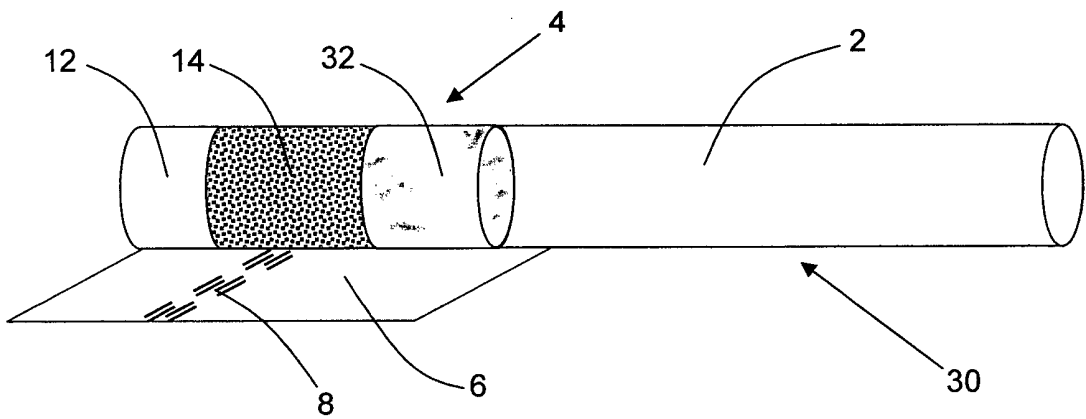
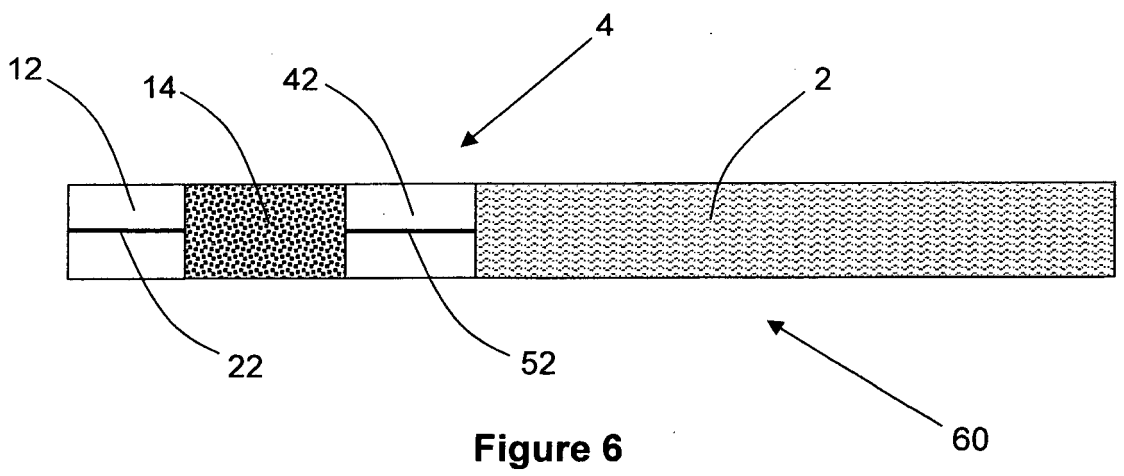
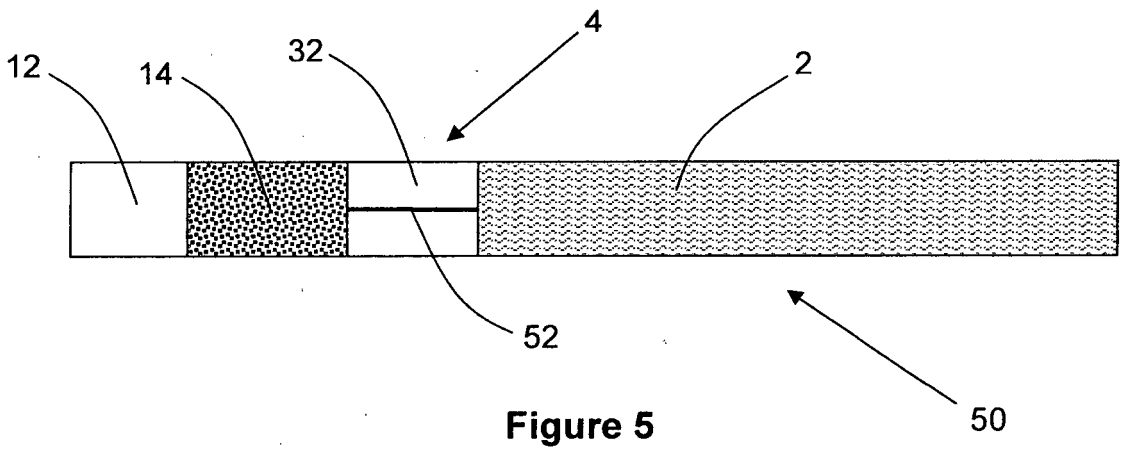
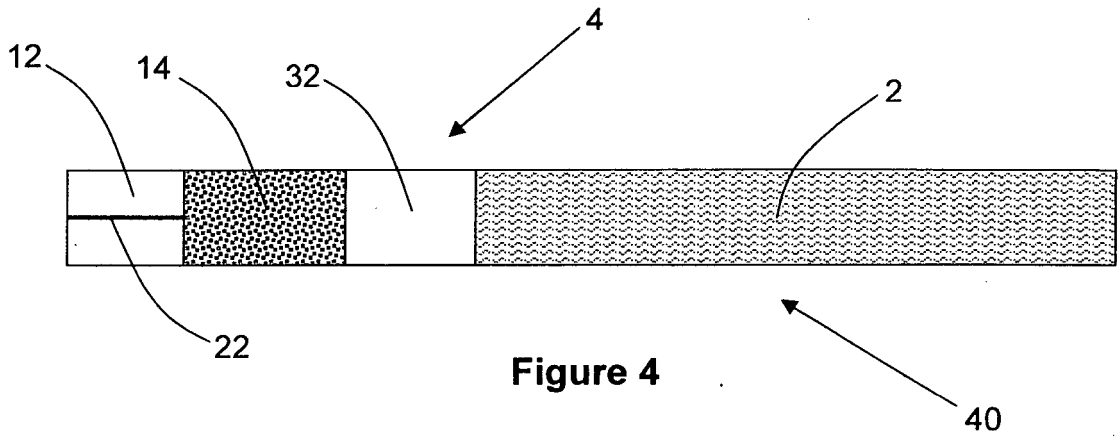
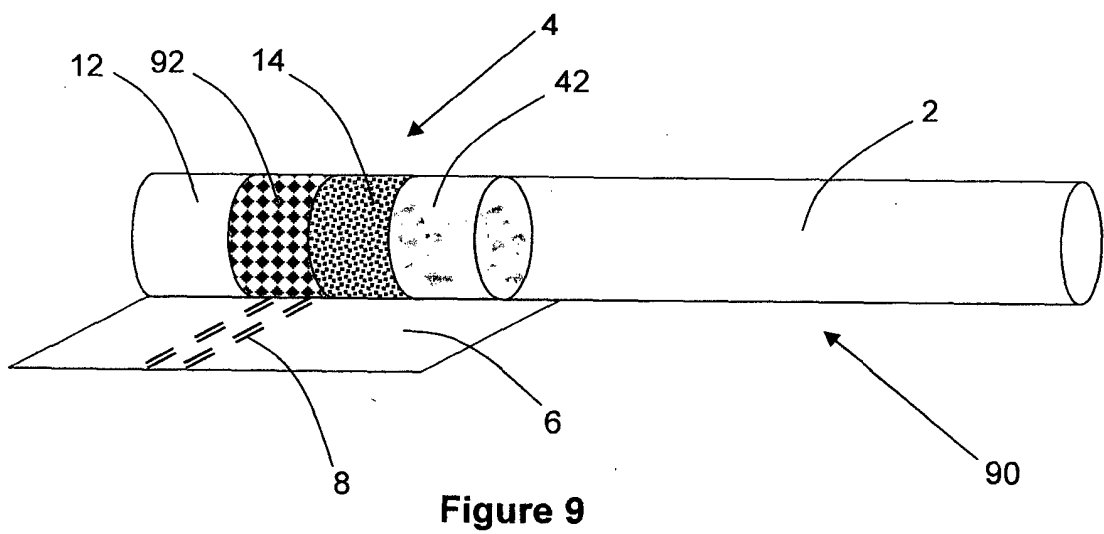
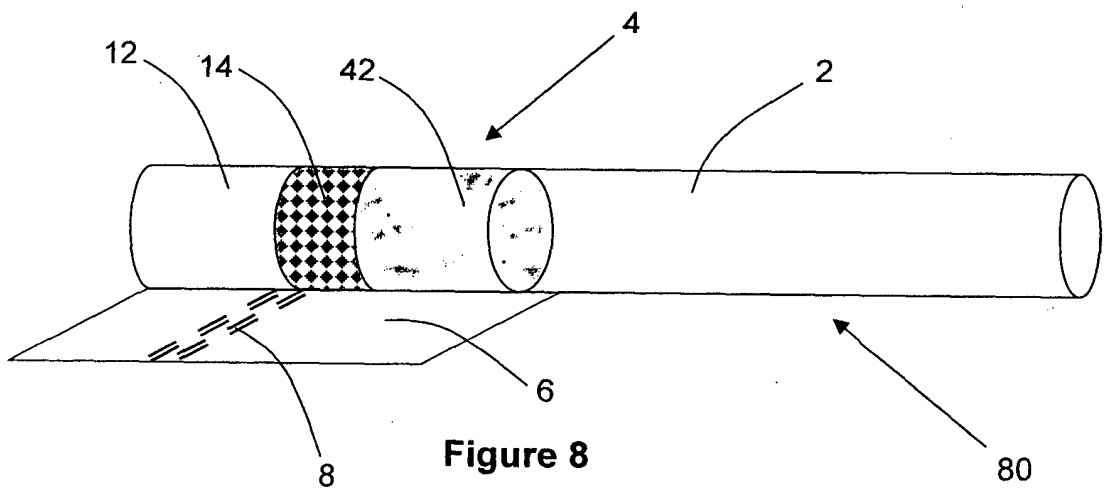
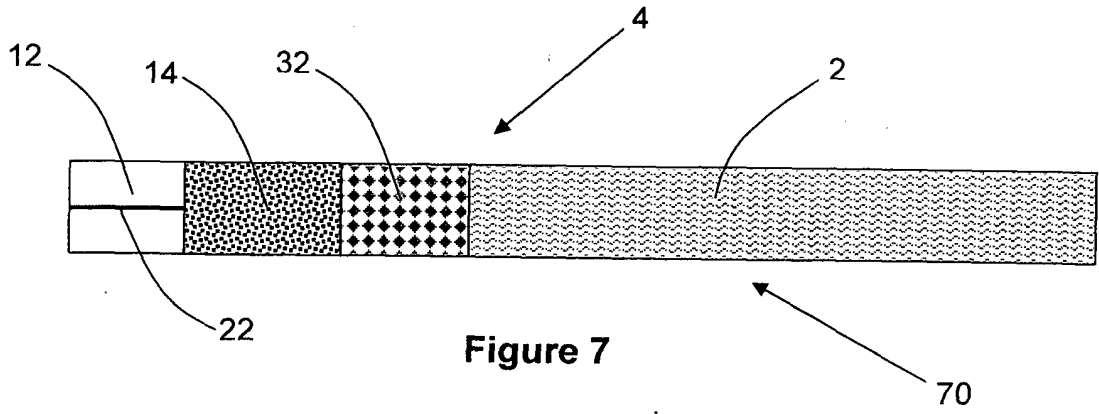

Figure 3





**REFERENCES CITED IN THE DESCRIPTION**

*This list of references cited by the applicant is for the reader's convenience only. It does not form part of the European patent document. Even though great care has been taken in compiling the references, errors or omissions cannot be excluded and the EPO disclaims all liability in this regard.*

**Patent documents cited in the description**

- WO 2006090290 A1 [0004]
- JP H2127194 B [0005]
- US 4281671 A [0033]
- US 7074170 B [0033]
- JP 10182842 B [0034]