



INTERNATIONAL APPLICATION PUBLISHED UNDER THE PATENT COOPERATION TREATY (PCT)

<p>(51) International Patent Classification⁶ : G10D 3/10</p>	<p>A1</p>	<p>(11) International Publication Number: WO 97/19442</p> <p>(43) International Publication Date: 29 May 1997 (29.05.97)</p>
<p>(21) International Application Number: PCT/US96/15113</p> <p>(22) International Filing Date: 23 September 1996 (23.09.96)</p> <p>(30) Priority Data: 08/561,774 22 November 1995 (22.11.95) US 08/630,416 3 April 1996 (03.04.96) US</p> <p>(71) Applicant: W.L. GORE & ASSOCIATES, INC. [US/US]; 551 Paper Mill Road, P.O. Box 9206, Newark, DE 19714 (US).</p> <p>(72) Inventors: HEBESTREIT, Charles, G.; 3450 E. Sparrow Avenue, Flagstaff, AZ 86004 (US). MYERS, David, J.; 1752 N. Rustlers Trail, Camp Verde, AZ 86322 (US). HUPPENTHAL, Joseph, A.; 2571 Fox Run Drive, Flagstaff, AZ 86004 (US). BETHKE, Glenn, T.; 3110 W. Shannon Drive, Flagstaff, AZ 86001 (US).</p> <p>(74) Agents: CAMPBELL, John, S. et al.; W.L. Gore & Associates, Inc., 551 Paper Mill Road, P.O. Box 9206, Newark, DE 19714-9206 (US).</p>		<p>(81) Designated States: AL, AM, AT, AU, AZ, BB, BG, BR, BY, CA, CH, CN, CZ, DE, DK, EE, ES, FI, GB, GE, HU, IL, IS, JP, KE, KG, KP, KR, KZ, LK, LR, LS, LT, LU, LV, MD, MG, MK, MN, MW, MX, NO, NZ, PL, PT, RO, RU, SD, SE, SG, SI, SK, TJ, TM, TR, TT, UA, UG, UZ, VN, European patent (AT, BE, CH, DE, DK, ES, FI, FR, GB, GR, IE, IT, LU, MC, NL, PT, SE).</p> <p>Published <i>With international search report.</i></p>

(54) Title: IMPROVED STRINGS FOR MUSICAL INSTRUMENTS

(57) Abstract

An improved musical instrument string is provided. The string (18) includes a polymer cover (26) that protects the string (16), from contamination while maintaining the original "lively" sound of the musical string. By supplying the cover (26) over a conventional string (16) and preferably over a conventional wound string, the string (16) is protected against contamination while also making the string easier to play. The preferred cover comprises at least one layer of expanded polytetrafluoroethylene (ePTFE) that is most preferably sealed with a polymer coating. In particularly preferred embodiments, a cover is applied over a portion of the length of the string having a relatively reduced variable mass. The result is that the string has relatively uniform mass along its entire length thereby assuring correct intonation.

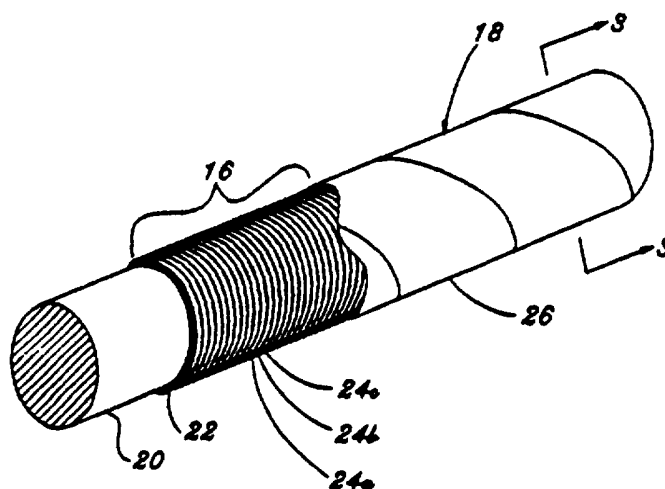

FOR THE PURPOSES OF INFORMATION ONLY

Codes used to identify States party to the PCT on the front pages of pamphlets publishing international applications under the PCT.

AM	Armenia	GB	United Kingdom	MW	Malawi
AT	Austria	GE	Georgia	MX	Mexico
AU	Australia	GN	Guinea	NE	Niger
BB	Barbados	GR	Greece	NL	Netherlands
BE	Belgium	HU	Hungary	NO	Norway
BF	Burkina Faso	IE	Ireland	NZ	New Zealand
BG	Bulgaria	IT	Italy	PL	Poland
BJ	Benin	JP	Japan	PT	Portugal
BR	Brazil	KE	Kenya	RO	Romania
BY	Belarus	KG	Kyrgystan	RU	Russian Federation
CA	Canada	KP	Democratic People's Republic of Korea	SD	Sudan
CF	Central African Republic	KR	Republic of Korea	SE	Sweden
CG	Congo	KZ	Kazakhstan	SG	Singapore
CH	Switzerland	LI	Liechtenstein	SI	Slovenia
CI	Côte d'Ivoire	LR	Liberia	SK	Slovakia
CM	Cameroon	LK	Sri Lanka	SN	Senegal
CN	China	LT	Lithuania	SZ	Swaziland
CS	Czechoslovakia	LU	Luxembourg	TD	Chad
CZ	Czech Republic	LV	Latvia	TG	Togo
DE	Germany	MC	Monaco	TJ	Tajikistan
DK	Denmark	MD	Republic of Moldova	TT	Trinidad and Tobago
EE	Estonia	MG	Madagascar	UA	Ukraine
ES	Spain	ML	Mali	UG	Uganda
FI	Finland	MN	Mongolia	US	United States of America
FR	France	MR	Mauritania	UZ	Uzbekistan
GA	Gabon			VN	Viet Nam

TITLE OF THE INVENTION

IMPROVED STRINGS FOR MUSICAL INSTRUMENTS

5

BACKGROUND OF THE INVENTION

1. Field of the Invention

The present invention relates to strings for musical instruments, and particularly to strings for musical instruments such as strings for guitars and the like that may be manipulated along their length.

10

2. Description of Related Art

There are a multitude of different types of musical strings employed today, each performing a different function. A typical guitar employs a straight (non-wound) string (such as "catgut," metal, or synthetic polymer (e.g., those disclosed in United States Patents 4,339,499 and 4,382,358)) for higher pitched notes, and wound metal or polymer strings (usually a wrapped metal or polymer winding over a core of nylon or similar material) for lower pitch notes. Wound strings rely on the additional string mass per unit length supplied by the spiral wrap of the wound string to supply lower pitched notes at an acceptable string tension. Existing string designs have been refined over many years to provide excellent musical tones, but the strings continue to be limited in many respects.

20

There is a large variety of stringed musical instruments employed today that require human contact along at least a portion of the strings, such as in the fingering and plucking of guitar strings in order to be played. While straight gage strings can be easily wiped of dirt and oil after use, wound strings tend to become contaminated with dirt, skin oils, and perspiration after even a few hours of playing. It is believed that dirt and other contaminants infiltrate windings of the string causing the windings to have limited motion. After a relatively short period of time, a typical wound string will become musically "dead," apparently due to the build-up of this contamination. Presently wound strings that lose their tonal qualities must be removed from the instrument and either cleaned or replaced. This process is burdensome, time consuming, and expensive for musicians who play frequently and care about tonal quality.

25

30

Another problem encountered with strings requiring fingering along a fingering board (e.g., a guitar fret board) is that a substantial amount of pressure must often be applied by the musician against the fingering board in order to produce different musical notes. Accomplished musicians normally develop extensive calluses on their fingers from years of playing their instruments. Despite such calluses, the pressure and friction generated by playing the instruments tends to be one of the primary causes of frustration and fatigue or injury for many musicians. The pain

35

associated with playing string instruments can be particularly discouraging for beginning music students.

Still another problem with conventional strings, and particularly conventional wound strings, is that the action of fingering quickly across the strings often generates unwanted noises. For instance, it is common to hear a "squeak" from guitar wound strings as a musician fingers move rapidly across a fret board or finger board. In order to avoid such squeaks, the musician must make a concerted effort to completely separate his or her fingers from the strings when repositioning on the fret or finger board. This repositioning action slows the musician's note changes and further increases fatigue.

It would seem that some of these problems could be addressed if the strings could be coated with some substance to avoid contamination of the wound string windings and/or to provide some cushioning or smooth, non-squeak, cover for the strings. For example, Fender Corporation offers a bass guitar string that employs a spiral wrap of a flat, stiff polymer tape (such as nylon) around the wound string. The polymer tape is not adhered to the wound string and does not conform to the underlying bass string, but, instead, is held in place merely by tightly helically wrapping the stiff flat tape around the bass string and holding the tape from unwinding with an outer-wrapping of thread at each end of the guitar string. The polymer tape is wrapped with its side edges abutting without overlap or of adhesion to adjacent tape wraps. Further, if the thread holding the polymer tape is damaged or removed, the polymer tape rapidly uncoils in a helical coil. It is possible to restore the string to the original condition by rewinding the polymer tape about the string and securing it with a thread winding.

While Fender Corporation's use of a stiff tape wrap may help reduce some contamination problems (which does not appear to be claimed by Fender) or may make the string somewhat more comfortable to play, the Fender bass guitar string has a distinctly "dead" sound when played. The relatively heavy and stiff wrapping is believed to limit the amount and duration of vibration of the string, particularly at higher harmonic or overtone frequencies, muffling or "deadening" its sound. As a result of the use of such a non-deformable covering, the string is unsuitable for most guitar applications where a conventional "bright" or "lively" guitar sound is sought.

Other problems may also emerge with the covering of a musical instrument string. For instance, where a cover is wrapped along the entire length of a guitar string or the like, the cover may wear and fray where the string is strummed with a pick. Even if this does not diminish string sound, at the very least fraying can look unsightly. On the other hand, where a cover is wrapped only along the fingering board, a fraying problem is eliminated but uneven mass along the length of the string may cause intonation problems.

It is accordingly a primary purpose of the present invention to provide an improved musical instrument string that includes a cover with one or more benefits, including being corrosion

resistant in the fret region, providing faster, easier, and/or more comfortable to play than conventional strings, and being less prone to generating unwanted noises when a musician's fingers are moved along the string.

It is a further purpose of the present invention to provide an improved covered musical instrument string that maintains correct intonation.

These and other purposes of the present invention will become evident from review of the following description.

SUMMARY OF THE INVENTION

10

The present invention is an improved musical instrument string for use on a variety of stringed musical instruments, including but not limited to guitars, double basses, pianos, violins, cellos, etc. The present invention is particularly suitable for use on musical instruments with strings that are prone to contamination and change in tonal quality over time, such as guitars and other instruments that have strings that are extensively handled during use.

15

The string of the present invention can employ a conventional wound string, such as a string having a center core and a spiral winding used to produce lower notes, and a polymer cover applied around and adhered to the wound string. The preferred cover comprises porous polytetrafluoroethylene (PTFE) in the form of one or more tapes, sheets, or tubes that enwrap the wound string and protect the wound string from contamination. The cover of the present invention is unique over all previous attempts to cover a musical string in that the cover is selected and applied so as not to significantly degrade the normal sound of the musical instrument. The cover therefore is substantially a non-dampening cover.

20

The cover of the present invention is applied so as to provide a lubricious covering, and to protect the string from contamination and corrosion with little or no interference of the free movement of the wound string. Preferably, an expanded PTFE is employed that is longitudinally stretched so as to be relatively non-deformable in its longitudinal direction and relatively deformable in its transverse direction. By wrapping this cover around the wound string with the longitudinal axis of the cover oriented at an angle to the longitudinal axis of the wound string, the cover will maintain its position and conform to the wound string but will still permit sufficient movement of the windings to maintain tonal quality.

25

30

If an adhesive is applied to hold the cover to the wound string, bonding should be accomplished to assure that winding movement is not diminished. For example, a discontinuous coating of adhesive will provide secure attachment of the covering to the winding without interfering with the vibration of the wound strings.

35

The performance of the string of the present invention can be further enhanced by applying an additional layer of material on the outside of the expanded PTFE covering, such as a fluorinated ethylene propylene (FEP) polymer. This additional layer is believed to provide a number of important benefits, including better adhesion of the cover layer to itself, and improved resistance to wear and contamination. Additionally, it has been observed that an outside layer of such material may actually improve tonal quality of the string over use of a cover without such a layer. Unlike the Fender string's thick polymer cover previously described, the cover of the inventive string cannot be removed from the main string in one continuous piece and cannot be put back on the string when it is removed by damage or dissection.

While contamination resistance and improved string life are important benefits of the present invention, increased finger comfort or "playability" is an equally exciting advantage. The string of the present invention is much more comfortable to use than conventional strings without covers. This results in the ability of a musician to play longer and with less fatigue. Moreover, since a fluoropolymer cover, such as PTFE, or FEP or a composite of these materials, is extremely smooth and slippery, the strings of the present invention are far less prone to "squeaking" during fingering. This allows for faster and less tiring fingering techniques without generating unwanted noise. This is also believed to make the guitar easier to learn and master by beginning players.

It has been determined that when this cover is attached to only a portion of a musical instrument string, an imbalance in mass is formed over the length of the string (i.e., the mass over one segment of the string is different from the mass over another segment of the string). The result is that a slight but distinct change in intonation has been noted during play. This problem is corrected with the string of the present invention by adjusting the mass of the underlying (i.e., "base" or "main") string along the length of the string. As the terms "base" and "main" are used herein, it is intended to refer to a precursor string of the present invention before a covering is applied. By reducing the relative mass of the portion of the main string that is provided with the polymer covering, it has been shown that correct intonation can be maintained along the entire length of the string. The string's mass need only be adjusted enough to compensate for the mass of the cover added to the string. Such modification of mass of the string can be accomplished through any suitable means, including grinding or otherwise reducing the diameter of the string along the area to be covered, separating the windings of the strings along the area to be covered, and/or adding additional mass to the string along the portion that is left uncovered.

DESCRIPTION OF THE DRAWINGS

The operation of the present invention should become apparent from the following description when considered in conjunction with the accompanying drawings, in which:

Figure 1 is a three-quarter perspective view of a guitar having strings of the present invention;

Figure 2 is a three-quarter isometric view, partially in cut-away, of one embodiment of a string of the present invention;

5 Figure 3 is an enlarged transverse cross-section view along line 3-3 of Figure 2, with the cover shown enlarged for detail;

Figure 4 is an enlarged longitudinal cross-section view of a portion of the cover of the string of Figures 2 and 3;

10 Figure 5 is an enlarged longitudinal cross-section view of a portion of the cover of a second embodiment of a string of the present invention;

Figure 6 is an enlarged longitudinal cross-section view of a portion of the cover of a third embodiment of a string of the present invention;

Figure 7 is an enlarged longitudinal cross-section view of a fourth embodiment of a string of the present invention;

15 Figure 8 is an enlarged longitudinal cross-section view of a fifth embodiment of a string of the present invention;

Figure 9 is an enlarged longitudinal cross-section view of still another embodiment of a string of the present invention, wherein a coating provided as a covering for a wound string;

20 Figure 10 is an enlarged longitudinal cross-section view of yet another embodiment of a string of the present invention, wherein another embodiment of a coating is provided as a covering for a wound string;

Figure 11 is an enlarged longitudinal cross-section view of a covering of the present invention on a straight musical instrument string;

25 Figure 12 is an enlarged longitudinal cross-section view of another embodiment of a covering of the present invention on a straight musical instrument string;

Figure 13 is an enlarged longitudinal cross-section view of another embodiment of a string of the present invention, wherein a covering is provided around each of the individual windings of the wound string;

30 Figure 14 is a three-quarter isometric view, partially in cutaway, of another embodiment of a string of the present invention, in this instance employing a wrap of three (3) opposing layers;

Figure 15 is a schematic depiction of sound evaluation equipment used to test the strings of the present invention;

Figure 16 is an enlarged longitudinal cross-section view of a string of the present invention having a partial cover and variable mass main string;

35 Figure 17 is an enlarged longitudinal cross-section view of a string of the present invention having a full cover and reduced main string mass along the length of the cover;

Figure 18 is an enlarged longitudinal cross-section view of a string of the present invention having a partial cover and a modified winding on the main string to reduce main string mass beneath the cover;

5 Figure 19 is an enlarged longitudinal cross-section view of an uncovered string having variable mass along its length;

Figure 20 is an enlarged longitudinal cross-section view of a string of the present invention having a partial cover and additional string mass added to a portion of the main string that is not covered;

10 Figure 21 is an enlarged longitudinal cross-section view of a string of the present invention having a partial cover and another embodiment of additional string mass added to the portion of the main string that is not covered;

Figure 22 is an isometric view of yet another embodiment of a covered string of the present invention, in which a portion of the string is left uncovered only in that portion of the string where the string is strummed;

15 Figure 23 is an enlarged longitudinal cross-section view of a string of the present invention having a partial cover and still another embodiment of additional string mass added to the portion of the main string that is not covered;

20 Figure 24 is an enlarged longitudinal cross-section view of a string of the present invention having a partial cover and another embodiment of string mass being subtracted from the portion of the main string that is covered;

Figure 25 is an enlarged longitudinal cross-section view of a string of the present invention having a partial cover and reduced string mass under the portion of the main string that is covered; and

25 Figure 26 is an enlarged perspective view of a string of the present invention having a two angle wrap construction.

DETAILED DESCRIPTION OF THE INVENTION

30 The present invention is an improved string for use with a variety of musical instruments employing strings. It is contemplated that the string of the present invention may be useful in many different types of musical instruments, such as but not limited to guitars, double basses, pianos, violins, cellos, etc.

35 Figure 1 illustrates a conventional six string guitar 10, one such musical instrument that can benefit from employing the strings of the present invention. All conventional guitars include a "fret" or "fingering board" 12, across which multiple strings, 14a, 14b, 14c, 16a, 16b, and 16c, are strung

and against which the strings are pressed to form different notes. A typical six string guitar includes three relatively "high" note strings, 14a, 14b, 14c, and three relatively "low" note (or "bass") strings, 16a, 16b, 16c. High note strings 14 are generally formed from a straight "non-wound" material, such as "catgut," metal, or polymer. In order to achieve significantly lower notes without
5 increasing the length of the string or unduly increasing its thickness, low note strings 16 generally employ a wound string construction.

The form of a typical wound string 16 (e.g., a guitar bass string) can be seen inside the string 18 of the present invention illustrated in Figures 2 and 3. As is shown, wound strings 16 employ a core 20, such as a straight gauge metal, catgut or polymer, and a winding 22 (e.g., metal
10 or polymer) wrapped repeatedly around the core 20. The winding 22 is held in place around the core by tension and the anchoring of it at its ends.

When a conventional wound string 16 is played for a period of time, it tends to lose its tonal quality, apparently due to "contamination" of the string. It is believed that proper tonal quality of a wound string 16 is dependent upon allowing movement between individual wraps 24a, 24b, 24c,
15 etc., of the winding 22 during play. Contamination in the form of dirt, oil, sweat, oxidation, etc., tends to become entrapped within the winding 22, causing limited motion of the individual wraps 24. This is a particular problem on a finger board of an instrument because of the constant handling of the strings in that area. As a result, after a relatively short period of play, wound strings begin to diminish in tonal quality. Serious musicians who care about tonal quality are then often
20 required to remove and replace or clean the wound strings on a regular basis to maintain proper sound.

In order to address this problem, the present invention wraps the wound string 16 with a cover 26 along at least a portion of its length. The cover 26 of the present invention serves to seal the winding 22 of the string from contamination during handling, while avoiding the problem of
25 restricting movement of the individual wraps 24.

The form of the cover 26 is believed to be quite important in the operation of the present invention. Although a wound string 16 may theoretically be wrapped with virtually any material to reduce contamination, there are a number of important considerations in choosing an appropriate cover. The foremost problem with encasing the strings in some covering is that many covering
30 materials tend to deaden the sound of the strings. This result is to be expected when a string vibrates somewhat out of phase with a cover, which will naturally reduce the amount and duration of the vibration of the string. A cover that is not adhered to the strings, such as that employed with the Fender Corporation wrapped bass strings, has been shown to produce a particularly "dead" sound. However, adhering and conforming a cover to the strings may tend to restrict the
35 movement between the individual wraps 24 of the winding. This may also be expected to deaden the sound, much in the same way as contamination does.

Another problem with any string cover is that the cover must be capable of withstanding substantial wear and abrasion during use. While adhesion of the cover to the underlying string may reduce abrasion between the cover and the string during use, as has been noted, such adhesion may also restrict the vibration of the string.

5 The present invention solves the problem of string contamination with minimal diminishing of the lively sound of the string. This is accomplished by wrapping at least a portion of the string with a polymer cover that is deformable enough to allow movement of the wraps of the winding during play. Preferably, the cover is formed from a material that is deformable enough to permit relatively free movement of the wraps 24 even when the cover is at least partially adhered to the
10 winding. Further, it is important that the cover be sufficiently durable to withstand the abrasion occasioned by playing of the string.

As the term "deformable" is used herein, it is intended to include any process or state whereby a covering material alters its shape under the normal pressures and stresses encountered by a musical instrument string. It is particularly preferable that a deformable cover used in the
15 present invention allows for the normal movement of string windings along the longitudinal axis of the string while including at least some recovery (that is, elasticity) so that the cover tends to return to its original shape upon removal of the pressure or stress. The cover of the present invention should be sufficiently deformable along the length of the string so as to maintain the tonal quality of the string.

20 Materials suitable for use as a cover of the present invention include, but are not limited to, the following: polytetrafluoroethylene (PTFE) including porous PTFE and particularly including porous expanded PTFE (ePTFE); fluorinated ethylene propylene (FEP); polyethylene including ultrahigh molecular weight polyethylene; perfluoro alkoxy resin (PFA); polyurethane; polypropylene; polyester; polyimide; and polyamide.

25 The preferred string cover of the present invention comprises a porous polymer material such as uniaxially expanded polytetrafluoroethylene. This material has demonstrated exceptional durability with properties that maintain excellent tonal qualities for the covered string. Porous expanded PTFE, such as that made in accordance with United States Patents 3,953,566,
3,962,153, 4,096,227, and 4,187,390, all incorporated by reference, comprises a porous network
30 of polymeric nodes and interconnecting fibrils. This material is commercially available in a variety of forms from W. L. Gore & Associates, Inc., Newark, DE.

Expanded PTFE is formed when PTFE is heated and rapidly expanded by stretching in at least one direction in the manner described in the above listed patents. The resulting expanded PTFE material achieves a number of desirable properties, including exceptional strength in the
35 direction of expansion, and exceptionally high flexibility, and conformability. Interestingly, although expanded PTFE material is quite strong and relatively non-deformable in the direction of

expansion, the oriented characteristics of the fibrillar microstructure make the material relatively deformable and easily distorted in a direction other than the direction of stretch. As is known, the amount of strength and deformability of the expanded PTFE can be adjusted by varying the expansion procedures, providing a wide degree of strength, porosity, and deformability in different directions by changing the direction and amount of expansion.

As the term "expanded PTFE" is used herein, it is intended to include any PTFE material having a node and fibril structure, including in the range from a slightly expanded structure having fibrils extending from relatively large nodes of polymeric material, to an extremely expanded structure having fibrils that merely intersect with one another at nodal points. The fibrillar character of the structure is identified by microscopy. While the nodes may easily be identified for some structures, many extremely expanded structures consist almost exclusively of fibrils with nodes appearing only as the intersection point of fibrils.

The preferred expanded PTFE cover for use with most wound strings is one with above about 50% porosity.

For use on a conventional guitar, the string may be covered only along the fret board, where the strings undergo the greatest amount of handling. By leaving the string uncovered in the region where the string is strummed, the life of the string of the present invention is believed to be prolonged since the cover will not be exposed to harsh wear from a pick, fingernails, etc., imparted during the process of play. It should be understood, however, that suitable strings of the present invention may include covers extending over the strumming region of the string. In fact, such a construction may be beneficial under certain conditions, such as when the strings are being played with fingers alone.

It is believed that by wrapping the film about the string at an angle closer to perpendicular to the longitudinal axis of the string that abrasion resistance of the covering is improved. Conversely, however, sound quality of the string may be adversely affected as this wrap angle approaches perpendicular. At the present time a wrap angle of about 20 to 30 degrees off perpendicular in the strumming region of the string is believed to be preferred to balance durability with tonal quality. Alternatively by wrapping the film about the string at an angle further from perpendicular to the longitudinal axis improves the feel and comfort of the string. Wrap angles of about 30 to 60 degrees off perpendicular in the fret region of the string are believed to be preferred to optimize comfort and tonal quality. Consequently, it may be preferred to combine the two different wrap angles on the same string covering the entire string (that is a first wrap angle for the fret region and second wrap angle for the strumming region).

The difficulty in using two different wrap angles on two different portions of the same string is that if the same length of tape having a constant width and thickness is used for the two different wrap angles, the wrap angle closest to perpendicular results in more overlap of the tape and a

greater mass per unit length of the covering in that region of the string. This can be avoided by using a separate length of tape for the portion having the wrap angle closest to perpendicular wherein the tape is narrower and/or thinner so that less mass is added with each wrap of the tape. Alternatively, if the wrap angles differ in mass per unit length of the string by a ratio of about 2:1, the lighter covered region (wrap angle furthest from perpendicular) can be wrapped twice with the same tape by wrapping down the string in one direction and then after reaching the end of the string, wrapping a second layer back in the opposite direction whereby the mass of the tape in that portion of the string is doubled and matches the mass per unit length of the wrap angle closest to perpendicular.

It should be noted that direction and pitch of the cover wrapping in relation to the direction and pitch of the winding of the main string may effect abrasion, comfort, and tonal quality of the string.

There are a number of ways that the string of the present invention may be even further improved. First, while the cover of the present invention may be applied with the tension of a helical wrap (such as the wrap of the cover 26 shown in Figure 2) alone keeping it attached to the string, it is believed preferred to employ some form of adhesive on the cover before it is applied to the string, and/or a coating over the cover to help retain the cover to the string. In choosing an adhesive, it is very important to keep in mind that an adhesive applied under the cover may have the undesirable effect of adhering the windings of the string together, thereby limiting the vibration of the string.

One method of attaching the cover 26 to the winding 22 is by using a continuous or discontinuous coating of adhesive. As is shown in Figure 4, by applying adhesive coating 28 to a polymer layer 30, sufficient adhesion can be provided without introducing enough adhesive to seep within the winding 22. In this manner, the adhesive will not interfere with the normal movement between the windings.

A number of different adhesives may be employed in the present invention. The adhesives can be thermoplastic, thermosetting, or reaction curing types, in liquid or solid form, selected from the classes including, but not limited to, polyamides, polyacrylamides, polyesters, polyolefins (e.g., polyethylene), polyurethanes, and the like. Particular adhesives that may be employed in the present invention include polyurethane, FEP, or PFA. Suitable application means include gravure printing, spray coating, powder coating, and the like.

The preferred polymer cover is expanded PTFE, and the preferred adhesive coatings are thermoplastics of lower melt point than the crystalline melt point of the PTFE. Thermoplastic adhesives such as FEP #NP-20FG films available from Norton Performance Plastics are most preferred.

Coated porous expanded PTFE film can be made by a process which comprises the steps of:

- a) contacting one surface of a porous PTFE substrate, usually in the form of a membrane or film approximately 0.025 mm (0.001") thick, with another layer which is preferably a film of FEP approximately 0.012 mm (0.0005") to 0.05 mm (0.002") thick or alternatively of another thermoplastic polymer;
- b) heating the composition obtained in step a) to a temperature above the melting point of the thermoplastic polymer;
- c) stretching the heated composition of step b) at about 4:1 ratio while maintaining the temperature above the melting point of the thermoplastic polymer; and
- d) cooling the product of step c); and
- e) slitting the film to the desired application width.

In addition to FEP, other thermoplastic polymers including thermoplastic fluoropolymers may also be used to make this coated film. The adhesive coating on the porous expanded PTFE film may be either continuous (i.e., covering virtually all of the surface pores of the porous PTFE and rendering the cover essentially non-porous) or discontinuous (i.e., leaving some of the surface uncovered, thereby maintaining some degree of cover porosity through the coated film) depending primarily on the amount and rate of stretching, the temperature during stretching, and the thickness of the adhesive prior to stretching.

The cover of the present invention may be applied in a variety of manners while maintaining the benefits of the present invention. In addition to the preferred helical wrapping of the cover described above, the cover may also be wrapped longitudinally (in a "cigarette wrap" manner), or as a continuous and seamless tube surrounding the string. Regardless of the type of covering procedure, it is believed important that the cover remains deformable in the longitudinal axis of the string. Multiple layers may also be applied.

It should be appreciated that the cover of the present invention may be formed through a number of different constructions. Figure 5 illustrates a cover 26 that employs an outer coating 34, a first polymer layer 36, a second polymer layer 40, and a continuous or discontinuous adhesive layer 42 adhered to first polymer layer 36. This construction provides a thicker and more durable cover 26. Additionally, by providing multiple polymer layers 36, 40, the deformable and strength properties of the cover can be further optimized.

It is most preferred to provide at least two polymer layers of expanded PTFE, each having been stretched in a longitudinal direction, with each of the expanded PTFE layers wrapped at different angles to each other. This is accomplished by two sequential helical wrappings applied over the instrument string at approximately equal but opposite pitch angles which are measured

respectively from opposite ends of the longitudinal axis of the string (i.e., the pitch angles of the first and second wrappings are measured from opposite ends of the string). This construction is believed to provide excellent strength and durability while maintaining good deformability along the length of the string.

5 Still another embodiment of the present invention is shown in Figure 6. In this instance, the cover 26 comprises an outer coating 34, a first polymer layer 36, and a second polymer layer 40 over winding 22. While the polymer layer 36 may be attached to the winding 22 with some form of adhesive, it is believed that a tight wrap of the polymer cover layers 36 and 40 may be adequately secured by the outer coating 34.

10 A further example of the present invention is shown in Figure 7. In this embodiment, winding 22 is provided with a cover 26 in the form of a wrapped polymer layer 30 having overlapping edges and thereby forming a continuous cover. The polymer layer may optionally be heated to thermally bond the overlapped edges together. The cover 26 may or may not include an adhesive coating on its outwardly facing surface, such as a coating of FEP polymer.
15 The adhesive coating serves to adhere the wraps together and also provides an additional protective layer to shield the cover from wear and contamination.

 Yet another embodiment of the present invention is shown in Figure 8. In this embodiment, windings 22 are protected within a continuous and seamless polymer cover 52. The preferred continuous and seamless cover comprises a sleeve of polymer material (such as
20 a thin, extruded sleeve of expanded PTFE, FEP, PFA, or the like). While the sleeve cover 52 may be adhered in place, it may be desirable to provide a sleeve of PTFE or other shrinkable material that can be shrunk by heat or tension around the winding 22. Again, it is believed that the cover 52 should be sufficiently deformable along its longitudinal axis to permit relatively free movement of the windings.

25 In addition to protecting the strings of the present invention from contamination, it has been determined that the cover of the present invention also makes the strings easier to play. The cover provides some cushioning of the strings and provides a layer of protection from the friction of conventional strings against a musician's fingers. The result is a string that is much easier to play for longer periods of time without discomfort and with less fatigue.

30 Another important advantage of the strings of the present invention is that they experience significantly less unwanted noise when played. It has been shown that the familiar "squeak" that occasionally occurs when conventional wound strings are rapidly fingered along their length can be diminished or eliminated using the strings of the present invention. The inventive string therefore should allow faster and easier fingering techniques without unwanted
35 noise and with greatly reduced fatigue. It is believed that the elimination of the extraneous

"squeak" noise of guitar or other musical instrument strings without diminishing the tonal quality of the strings may result in one of the most important benefits of the present invention.

It should be noted that some of the beneficial results of the present invention may be realized by employing an adhered polymer coating alone as a cover. Suitable polymers for this application may include PTFE dispersion, polyurethane, FEP, PFA, or the like. A PTFE
5 dispersion can be coated on the string and then baked in place. Polymers such as polyurethane, FEP, PFA, etc., will adhere to the string and may be employed as adhesives or further processed to improve adhesion or durability.

Figures 9 and 10 illustrate two embodiments of such coatings applied to wound strings. Figure 9 shows an enlarged longitudinal cross section of an embodiment wherein coating 54
10 provides a continuous covering of the wound string in that the coating 54 spans adjacent windings without helical abutted seams 22. Alternatively, as shown by the enlarged longitudinal cross section of Figure 10, coating 55 may provide a polymeric covering that does not span between adjacent individual windings 22. In this instance, it is preferred that the discontinuous
15 coating 55 on each winding 22 closely abuts the adjacent discontinuous coating 55 so as to limit penetration of contamination between the windings.

Polymeric coverings may also be provided for straight (non-wound) strings as well as for wound strings. Such a covering on a straight string provides increased lubricity and protection from corrosion and consequently allows faster and more comfortable playing. The covering may
20 be provided along only a portion of the length of a string if desired. For example, the covering may be provided only along the fret board portion of a guitar string.

Figure 11 shows an enlarged longitudinal cross section of a straight string 56 provided with a continuous and seamless covering 58 over at least a portion of the length of string 56. Covering 58 may take the form of a continuous and seamless tube, such as a length of heat
25 shrink tubing fitted over string 56, or may take the form of a coating of the types described previously adhered to the surface of string 56. As shown by the enlarged longitudinal cross section of Figure 12, covering 58 over straight string 56 may also take the form of a polymeric film helically wrapped around the string 56 so as to have overlapping edges, thereby forming a continuous covering. Such a film covering may or may not be adhered to the surface of the
30 string 56. Appropriate films for use in this embodiment are of the types described previously as coverings for wound strings. Figure 13 illustrates still another embodiment of the invention wherein the covering 61 is applied to the winding 22 prior to being wound onto the core 20. This covering may also be in the form of a coating.

One of the additional benefits that may be experienced with the present invention is
35 improved shelf life of the strings. Musical instrument strings often begin to degrade while being stored before they are even installed. The primary problem in this regard is believed to be

oxidation that attacks both wound and unwound strings while they are stored in their original packaging. The cover of the present invention can serve to seal the strings from air and moisture, thus reducing or eliminating this problem. It is contemplated within the scope of the present invention to provide a cover along the entire length of the strings in their original packaging to further protect against such contamination problems. The strings can then be used with the entire string covered or scoring can be provided to allow unwanted portion of the covering to be removed from the string (e.g., stripped) before they are played.

Without intending to limit the scope of the present invention, the following examples illustrate how the present invention may be made and used:

Example 1

This Example was made from a purchased FENDER 150SXL nickel wound guitar strings 0.61 mm (0.024 in.), 0.81 mm (0.032 in.), and 1.067 mm (0.042 in.) diameters. The covering was two types of ePTFE film, one type provided with a continuous coating of FEP adhesive on one surface and one with a discontinuous coating of FEP on one surface. Both types of ePTFE film had average fibril length of about 50 microns and a bulk density of about 0.35 g/cc. Average fibril length was estimated from scanning electron micrographs of the surface of the ePTFE film. The film with a continuous coating of FEP was 0.025 mm (0.001 in.) thick. The film with a discontinuous coating of FEP was 0.015 mm (0.0006 in.) thick. As is shown on Figure 14, the wrap configuration was a bias wrapping of three (3) 6.35 mm (1/4 in.) wide composite film tapes 60a, 60b, 60c placed in alternating layers with each layer applied in a different direction. The tapes were wrapped with approximately 50% overlap at approximately 30° from perpendicular to the string longitudinal axis. The first layer was ePTFE with a continuous FEP coating facing down on the wire; the second layer was ePTFE with a discontinuous FEP coating facing up away from the wire; and a third layer was ePTFE with a continuous FEP coating facing up away from the wire.

The string was placed under tension and heated to 345°C in a convection oven set at 375°C. The string was removed from the oven when the surface of the string reached 345°C, as determined by a thermocouple attached to the exposed metal surface of the string and monitored by a readout.

Example 2

This example was made from a purchased FENDER 150SXL nickel guitar string 1.067 mm (0.042 in.) diameter. The cover was ePTFE film with no adhesive and approximately 0.010 mm (0.0004 in.) thick. The ePTFE film had an average fibril length of about 70 microns and a bulk density of 0.30 g/cc. The tape and wrap configuration was a bias wrap as in Example 1

except that only two alternating layers were applied in opposing directions. The string was heated as described in Example 1.

Example 3

5 This example was made from purchased ERNIE BALL nickel wound 0.61 mm (0.024 in.) and 1.067 mm (0.042 in.) diameter guitar strings. The strings were covered with a continuous length of TFE shrink tubing from Zeus Industrial Products, Inc., of Raritan, NJ. The coverings were shrunk around the strings by heating the strings to 327°C in an oven set at 375°C, as determined by a thermocouple and temperature readout as in previous examples. Covers were
10 as follows:

	<u>Guitar String Dia.</u>	<u>Shrink Tube Cover</u>
	0.61 mm (0.024 in.)	0.76 mm (0.030 in) to 0.31 mm (0.012 in.) dia x 0.08 mm (0.003 in) wall thickness
15	1.067 mm (0.042 in.)	1.17 mm (0.046 in) to 0.56 mm (0.022 in.) dia x 0.05 mm (0.002 in) wall thickness

Example 4

This example was made from a purchased ERNIE BALL nickel wound string 0.81 mm
20 (0.032 in.) diameter. This string was covered with a ZEUS 1.17 mm to 0.56 mm (0.046 in. to 0.022 in.) TFE shrink tube as in Example 3. The string was tested and the performance recorded before the shrink tube was heated and conformed to the wire.

Example 5

25 This example was made from a purchased FENDER 150SXL 1.067 mm (0.042 in.) diameter nickel wound guitar string. The string was helically tape-wrapped (one layer and one direction) with 3M Scotch 35 vinyl plastic electrical tape (available from 3M, Hutchinson, MN) with the adhesive against the wound wire. The tape was slit into 6.35 mm (1/4 in.) width and applied as in other examples. No heating was performed.

30

Example 6

This example was made from a purchased FENDER 150SXL 1.067 mm (0.042 in.)
diameter nickel wound guitar string. The string was covered with porous ultra high molecular weight polyethylene approximately 0.015 mm (0.006 in.) thick. The process involved helically
35 tape-wrapping as in other examples. The film was applied in one layer and in one direction with approximately 50% overlap. The string was then heated in the convection oven set at 200°C

and removed when the wire string reached 175°C, as determined by a thermocouple and readout as in other examples.

Example 7

5 A series of sample strings were made using a purchased FENDER bass guitar string #2200 2.33 mm (0.092 in.) diameter provided by Fender with a wrapping of polyamide (nylon flat tape) having abutted edges. The tape measured approximately 0.97 mm (0.038 in.) wide and approximately 0.33 mm (0.013 in.) thick.

10 To conduct a comparative test, four test samples were made using the same string. The samples were constructed as follows:

Sample 1: the FENDER string as received in the commercial package.

Sample 2: the FENDER string of Sample 1 was stripped of the nylon cover and tested as a bare metal wire wound string. This was the control string against which the other Fender samples of this example were tested.

15 Sample 3: the string of Sample 2 was covered with the two types of ePTFE films as used in Example 1. Four total layers in alternating directions were applied to the string:

Layer 1: ePTFE film with continuous coating of FEP;
FEP oriented down on the wire.

20 Layer 2: ePTFE film with discontinuous coating of FEP;
FEP oriented up away from the wire.

Layer 3: ePTFE with discontinuous coating of FEP;
FEP side oriented down on the first two layers.

Layer 4: ePTFE with continuous FEP coating;
FEP facing up away from wire.

25 The covered string was heated as described in Example 1.

Sample 4: the string used in the previous three samples was used again but with the addition of two layers of the ePTFE film described in the previous sample;

Layer 5: ePTFE film with continuous FEP coating;
FEP oriented down on the wire.

30 Layer 6: ePTFE film with continuous FEP coating;
FEP oriented up away from the wire.

Again the string was heated as described in Example 1.

Example 8

35 This example was made from a purchased D'ADDARIO wound guitar string part number J-16 Phosphorous Bronze Light 1.35 mm (0.053 inch) diameter. The object of this example was

to construct a covered string with a constant mass per unit length using two different wrapping angles on two different segments of the string

The process involved tape-wrapping with a film provided with a continuous coating of FEP as in Example 1. A 1/8 inch wide tape was selected for the covering. The FEP coated side was oriented facing down on the string windings. The tape-wrapping was started at a point approximately 40 cm from one end of the string (the fret segment) at an angle approximately 58° from perpendicular to the string longitudinal axis. The tape-wrapping sequence involved: traversing the wrapping at 6.68 mm (0.263 inch) per revolution to one end of the string, reversing the 58° angle to the opposite direction, traversing the wrapping back to the starting point, changing the wrap angle to 25° from perpendicular to the longitudinal axis of the string and traversing the wrapping at 1.98 mm (.078 inch) per revolution over the remaining uncovered segment (strumming segment) of the string. The finished string thus had two helical wrappings of the film applied at opposing 58° wrap angles on the fret region of the string and a single helical wrapping applied at a 25° wrap angle on the strumming region of the string. Wrapping at the 25° angle produced about twice as much overlap as the preceding wrapping at 58°. The covered string was not heated in a convection oven as in other examples.

To evaluate the mass of the string segments, the string was cut into two 25 cm lengths (one with 25° wrapping and one with 58° wrapping). First the string segments were weighed on a gram scale (calibrated to ± 0.004 g) followed by removal of the PTFE covering. Next the individual components were weighed separately on the same scale and the values recorded:

Covered string:
Fret segment = 2.671 g
Strumming segment = 2.676 g

Covering only:
Fret segment = 0.094 g
Strumming segment = 0.090 g

Wound string only:
Fret segment = 2.576 g
Strumming segment = 2.585 g

The above example demonstrates that by adjusting wrap angle and the feed rate of tape-wrapping a musical string of constant mass per unit length can be constructed to achieve the optimum material properties in each segment of the string.

Example 9

To demonstrate that the inventive string is less prone to unwanted noises associated with playing a sound test was performed. A GHS Progressive Electric Bass String 2.66 mm (0.105

inch) diameter was covered with a PTFE covering film provided with a continuous coating of FEP as in Example 1. The covering was applied with the FEP coated side facing down onto the wound string. The film tape was wrapped with approximately 50% overlap and at an angle approximately 30° from perpendicular to the string longitudinal axis. Only the fret segment
5 (approximately 60% of the string length) was covered with two layers, each layer being applied in the same direction. The string was also heated as in Example 1.

To perform the sound test, a sound level meter SPL-103 manufactured by Columbia Research Laboratories, Inc. was used to monitor sounds made by a celluloid pick being dragged along the longitudinal axis of the string in the covered segment and uncovered segment of the
10 string. To ensure consistency of the test, a fixture was constructed to apply 87 grams of force on the pick to the string surface and 163 grams of force for the lateral movement of the pick parallel to the longitudinal axis of the string.

With the weighted response set on the A scale and the meter set to the 90 dB range, the mean value for four sample tests was approximately 2dB for the uncovered segment and
15 approximately -6dB for the covered segment.

Example 10

This example was made from the same type of string of Example 8. The construction was also identical to Example 8 with the exception of employing a 1/4 inch wide film tape and
20 heated as in Example 1. The object of this example was to demonstrate the deformable characteristic of the inventive covering.

To evaluate the string covering, a section of cover material approximately 50 mm x 2.5 mm was removed from the fret segment of the string. This was accomplished by grinding the string along the longitudinal axis (on one side of the string in the fret area) and peeling the
25 untouched portion (the side opposite of the grinding) of the cover from the string windings.

A 38.1 mm (1.5 inch) section was marked on the sample as measured by a caliper. Next the sample was gripped at each end with clamping hemostats and pulled slowly by hand in the longitudinal direction to about 6 percent elongation and allowed to relax. After approximately 5
30 seconds the sample was again measured and determined to be the same length as its initial length.

Example 11

This example was accomplished by using MARTIN medium acoustic guitar strings. The object was to provide further evidence of the strings of the present invention exhibiting less of
35 the unwanted squeaking noise associated with playing a stringed instrument. To provide a subjective example of this characteristic, a professional musician played a song while being

recorded. First, the musician played the song on an EPIPHONE #PR350CE acoustic guitar equipped with the MARTIN medium acoustic guitar strings as purchased. Second, the musician played the song again on an identical guitar equipped with identical MARTIN strings supplied with a covering identical to the covering described in Example 9. The entire length of the wound strings were covered for this example.

A review of the resulting audio recording demonstrates that the strings of the present invention exhibit less squeaking noise (i.e., extraneous noise of the musician's fingers passing along the strings) while being played.

10 Testing:

Guitar strings from Examples 1-6 described above and comparable uncovered control strings were individually installed and tested on a PEAVY PREDATOR electric guitar. The string of Example 7 was installed and tested on a FENDER Jazz Electric Bass Guitar. The pickup of each guitar was amplified by using an ENVOY 110 amplifier. An HP 35670A dynamic signal analyzer was then connected to the amplifier output jack to both monitor and capture signal output. A fixture with a spring loaded mechanical arm was employed to create a consistent deflection of each string tested.

The control strings of Examples 1-6 were strings as purchased from the manufacturer which were compared to the inventive covered strings of the same type and size. The comparative data in Table 1 describe the difference of the amplitude of a sound produced by the control string versus the comparable inventive covered string for various harmonics, based on equal amplitude signals from both strings at the fundamental harmonic (i.e., the amplitudes (of the control and inventive strings) at the fundamental frequency were adjusted to a difference of zero). Subsequent harmonic values were calculated to reflect the actual amplitude difference in a range of harmonics. For example, if the intensity of the fundamental frequency of a coated string is -59dB and the intensity of the fundamental of a control string is -62dB, the adjustment is -3dB. To obtain the differences in subsequent harmonics the -3dB adjustment is added to the recorded value for each harmonic on the coated string. The coated string versus the control string difference thus eliminates any variability due to plucking or strumming the string. The data in Table 1 appear only where the dB difference was greater than 2 dB. A positive value indicates a larger amplitude for the covered inventive string than for the comparable control string while a negative value indicates the opposite result. The example types are described at the beginning of each numbered row of Table 1.

The same comparison was made of a FENDER Bass guitar string #2200 as described in Example 7 with additional comparisons for the final (eighth) 1/4-second of the two second period. These additional data are described in Table 2. This final 1/4-second is believed to be

particularly important on a bass guitar since it is generally desired for bass notes to be sustained during play. The FENDER control was Sample 2 of Example 7.

Analysis of the harmonic content and spectral shape of an acoustic wave is a complex problem. A conventional oscilloscope displays a signal in the time domain which represents the amplitude or intensity as a function of time. The amplitude at any instant of time is a result of the superposition of all the amplitudes of all harmonics present. The resulting waveform is a complex, time varying signal. Using a Dynamic Signal Analyzer (DSA) the information content of the recorded signal may be transformed using the Fast Fourier Transform (FFT) from the time domain to the frequency domain. The resulting display depicts the amplitude or intensity at each frequency, effectively decomposing the signal into its components. For the analysis, a Hewlett-Packard model 35670A DSA, serial number 3340-A00485, was used. This analyzer is basically a digital sampling, storage oscilloscope with a built in microprocessor and software which performs the FFT on the signal and displays the result on a CRT or stores the result on a floppy disk for post-processing analysis.

An electric guitar body was provided with an electric guitar pickup that directly sensed the string vibration. The fixture with the spring activated mechanical arm was attached to the guitar. A PINK PEARL brand rubber eraser was substituted for a conventional plastic guitar pick to reduce variable noise effects. The analysis equipment is depicted schematically in Figure 15.

To perform a sound measurement, the string under test was mounted on the guitar body, tuned to the correct pitch using the SABINE ST-1100 Autotuner, and deflected once with the PINK PEARL eraser attached to the test fixture. The DSA was configured to capture the first two seconds of the signal. The analyzer time capture was triggered to begin with the onset of the signal. The analyzer bandwidth was set to 1,600 Hz since there were no significant harmonics present in any of the strings tested beyond the tenth for the highest pitch string (D at a 146.83 Hz fundamental). This resulted in eight (8) blocks of data, each 1/4-second long, being recorded with 1024 individual samples per block. The FFT was performed on the stored signal with a resulting frequency resolution of 4 Hz.

The record for the two-second time capture was stored as an HP SDF format data file which is the native data format for the DSA. The FFT traces for the first and last blocks of the eight block capture were also stored. The HP supplied program "Viewdata" was used to examine each stored FFT trace. The peak amplitude of the signal at each harmonic and its corresponding frequency were recorded and input to a MICROSOFT "EXCEL" spreadsheet program for plotting purposes. The data for each covered string were compared to the corresponding control string without a covering by using equal amplitude signals at the fundamental frequency and then taking the difference between the covered and control strings at each higher harmonic. The first 1/4-second is believed to be the most relevant for analysis since

most guitar music is played with a fairly rapid tempo. The bass guitar string was also analyzed at the final eighth 1/4-second block since they are usually played with a longer sustained note.

The following subjective conclusions were drawn from this testing:

- 5 • On A and E strings, the 3 wrap ePTFE results in uniformly higher intensity higher harmonics; on a D string some harmonics were enhanced while others were attenuated.
- On E strings, ePTFE applied without adhesive and the TFE shrink tube had broadly higher intensities at higher harmonics. Both vinyl electrical tape and porous UHMWPE had some harmonics enhanced and some attenuated.
- 10 • The application of loosely applied heat-shrink TFE tubing to an A string results in reduced harmonic content. However, when shrunken as in Example 3 on the E and D string, there is greater intensity in harmonic content across most frequencies.
- On the FENDER bass A string, the meaningful comparison is believed to be at the last time frame tested since bass notes tend to be sustained during play. The data were gathered in eight 1/4-second blocks, and the comparisons at the eighth block are significant. The non-
15 deformable nylon tape wrapping of the Fender bass guitar string attenuated the harmonic content for all harmonics. The ePTFE covering resulted in increased harmonic intensity for nearly all frequencies.

The presence of a covering alters the harmonic content of the vibrations of a wound vibrating string. When the covering is ePTFE, with or without an adhesive, the resulting covered
20 string vibrates with more energy in the higher harmonics or overtones when compared to a string without a covering tuned to the same pitch. While pronounced increases in harmonic intensity were noted, some specific frequencies were attenuated below those of the controls for some constructions.

Human hearing, which peaks in sensitivity at around 3 kHz, is thus particularly sensitive
25 to higher harmonics of these generally low pitched strings. The subjective interpretation of greater intensity in higher harmonics is that the sound appears "brighter" or "fuller" for the inventive strings, even though one or more specific higher frequencies may be slightly attenuated when compared to the control string without a covering.

In all cases of the covered strings of the present invention, musicians experienced less
30 friction while fingering the strings than would be encountered with conventional strings without covers. This allowed for far more comfortable play over a longer period of time. With prolonged playing of the inventive strings over a period of weeks, it was observed that calluses that form on the musician's fingering hand actually diminished (probably from the reduced abrasion encountered with the inventive strings).

35 Another significant improvement observed was that extraneous noise ("squeak") from playing the inventive strings virtually disappeared as compared to conventional strings without

covers. This allowed for faster fingering techniques without "squeaking" during note changes, greater comfort, and less playing fatigue since fingers do not have to completely separate from the strings when changing position.

5 Since the degree of enhancement or attenuation of string sound was observed to vary using different types of covers on different types of strings, it may be beneficial to employ different polymeric covers on different string types in a set of strings in order to mix and match sound qualities.

Experiment

10 Initial testing of the strings of the present invention revealed that partially covered strings exhibited slightly incorrect intonation when they are played along their length, in particular, when played at the higher frets, such as the 9th and 12th frets. It is theorized that a uniform mass per unit length of the string may be necessary for proper intonation for all notes played.

15 To test this theory, three string conditions were characterized as described in Table 3. A series of 0.046 in. (1.17 mm) diameter "E" bronze wound guitar strings manufactured by S.I.T. of Akron, OH, were selected for sound measurement. A new string was used in each sample. All strings were individually installed on a GIBSON EPIPHONE acoustic guitar and tuned to the fundamental "E" note. The different notes played by hand were monitored by a KORG model DTR-1 TONE WORKS tuner manufactured by Korg, Japan. A minus value (cents) denotes a flat note and a plus value denotes a sharp note.

20 Sample A:

The first "E" string tested was unmodified as received in the package.

Sample B:

25 Using a gram scale, the weight of the second "E" string was determined to be 7.20 g. The string was then covered with ePTFE film having a continuous coating of FEP on one surface. The ePTFE had a fibril length of about 50 microns, and a bulk density of about 0.35 g/cc. The film was applied in a tape wrap configuration with the FEP-coated surface down against the wire and with approximately 50% overlap at approximately 30° from perpendicular to the string longitudinal axis. Two layers were applied in the same direction. Only the portion of the string directly over the fret board was covered (approximately 60% of the string length). The string was placed under tension and heated to 345°C, in a convection oven set at 375°C. The string was removed from the oven when the surface of the string reached 345°C as determined by a thermocouple attached to the exposed metal string surface and monitored by a readout.

35 After cooling, the string was weighed again and determined to weigh 7.46 g. The covering weight was therefore 0.26 g. Testing was performed as described above.

Sample C:

The third "E" string was selected and weighed as in Sample B. The string was very similar to Sample B, with a weight of 7.29 g. A covering weighing 0.26 g was also used for this sample. The metal wound string was reduced in mass by an abrasive sanding in the area directly over the fret board (0.26 g over approximately 60% of the string length). Next the area of reduced mass was covered with an ePTFE covering as in Sample B. Heating was also the same as in Sample B. Testing was performed as described above and values recorded on Table 3.

The modified string of Sample C is illustrated in Figure 16. The string 64 comprises an underlying main string 65 comprising a core 20 and a winding 22, and a cover 26 mounted only over a portion of the main string 65. As can be seen, the winding 22 is at full diameter along uncovered segment 66 and is significantly reduced in diameter along cover segment 68. The diameter of the main string 65 can be reduced through any suitable manner, including by shaving, grinding, acid treatment, etc. In this example the winding 22 along cover segment 68 was reduced in mass by abrasive sanding.

Table 3 illustrates the changes in intonation between these three sample strings. The conventional string of Sample A demonstrated true sound up through the 7th fret, but experienced slightly flat tone at the 9th fret and greater flat tone at the 12th fret. The coated string of Sample B began demonstrating slightly sharp tone at the 7th fret and showed a distinctly sharp tone at the 9th and 12th frets. By contrast, the improved string of Sample C demonstrated true intonation through the 9th fret and incurred only slight flat tone at the 12th fret. As can be seen, the modified string of the present invention actually demonstrated truer intonation than the conventional uncoated string across the entire fret board.

Based on this test, uniform mass/unit length of guitar strings may be desirable for correct intonation. As is set forth below, this condition can be achieved for a string having a covering over only a portion of its length through a number of various options, including providing a variable pitch winding on wound guitar strings, i.e., spacing the individual wraps further apart under the area of covering; reducing the mass of the windings in the intended area of the covering by grinding or other methods; and/or by increasing the mass of the strings along the segment that is uncovered.

Another embodiment of the present invention is shown in Figure 17. In this instance the string 64 comprises a main string 65 that has been reduced in diameter along its entire length. This is again accomplished by grinding, shaving off, or otherwise removing a portion of the winding 22 of the string. The main string 65 is then coated along its entire length with a cover 26.

In addition to removing a portion of the main string 65 to adjust for cover mass, there are a number of other options to achieve a similar functional result. Figure 18 illustrates a string 64 of the present invention where the winding 22 has been intentionally separated along the covered segment 68. This separation leaves gaps 70 between the individual wraps 24, and accordingly reduces the mass of the string in that area. This can be accomplished during the initial underlying string 65 construction or can be performed by altering the windings 22 following string formation. In either instance, the separation of the windings 22 should be such that the reduction in the mass of the underlying string along the covered segment 68 is approximately equal to the additional mass added by the cover 26.

Figure 19 illustrates a precursor string 72 to the partially covered string of Figure 16. It is contemplated that even uncovered this string, having a variable mass along its length, may have a number of unique uses. For instance, the segment of the string with reduced mass 74 presents a flatter profile, which may be more comfortable to play than a conventional wound string.

Still another approach to the present invention is shown in Figure 20. This string 64 employs a conventional main string 65. In order to equalize the mass along the string, however, an equalization coating 76 is applied over the uncovered segment 66 of the string. Again, this additional coating should be approximately equal in mass to the mass of the cover 26. The equalization coating 76 may comprise any suitable material, such as adhesive (e.g., FEP, PFA, etc.), metal plating, a further winding of metal or plastic or the like, a sleeve of additional material, etc. Since the purpose of coating 76 is to equalize the mass along the string by compensating for the mass of covering 26, it is probably desirable that this coating will have improved abrasion resistance or other properties that may make it more suitable for strumming of the instrument along the uncovered segment 66. Particularly preferred in this regard would be an equalization coating 76 such as metal plating. It should be recognized that the equalization coating 76 should be applied in such a manner that movement between the windings 22 of the string is not diminished.

Figure 21 shows yet another approach to construction of a string 64 of the present invention. In this instance, additional material 78 is placed under the windings 22 along the uncovered segment 66. This additional material, such as a thin gauge wire or the like, provides mass approximately equal to that of the cover 26 along the covered segment 68.

It has been recognized that coating the entire length of a string can lead to somewhat unsightly shredding of the covering in areas of high abrasion, and only covering a portion of the length of the string can lead to incorrect intonation. Figure 22 shows yet another approach to constructing an improved string 80 of the present invention. In this instance, the string 80 has a discontinuous cover 82a, 82b, leaving a short uncovered segment 84 approximately

corresponding to the area where high abrasion will occur on the string during use (e.g., on a guitar this would be the 8-10 cm segment where the string is fingered or picked during play). The uncovered segment should be as short as possible to minimize incorrect intonation.

5 The discontinuous cover 82a, 82b may be applied through any appropriate means, including by having a discontinuous wrap of the cover 82 around the underlying string or by removing the cover from the string after construction. Additionally, one or more score lines 86 or other means can be provided on the cover to allow portions of the cover to be quickly and easily removed by the musician at the desired location before or after abrasion to the cover has occurred.

10 Figure 23 illustrates an enlarged cross section of an alternative embodiment of the present invention wherein the main string 65 is provided with an additional winding 90 of small gauge wire around the outer surface of winding 22 which is provided only in the uncovered portion of the string to compensate for the mass of the cover 26 in the covered portion of the string.

15 Figure 24 illustrates still another alternative wherein a straight or non-wound main string 20 (i.e., a string without an outer winding) is made to have a smaller diameter and consequent lighter mass along covered portion 92 than along uncovered portion 94. Such a non-wound string having a cover over only a portion of its length and made so as to have a consistent mass per unit length when the mass of the cover is included in the total mass, is expected to have
20 many of the advantages described previously.

Still another method of string mass equalization is shown in Figure 25. In this instance, the covered portion 92 of the length of the string is provided with a winding 96 that is of smaller diameter and of less mass than the winding 98 of the uncovered portion 94. Such a construction obviates the need to otherwise modify the mass of a precursor string by means such as plating,
25 grinding, etc. While it is anticipated that the string shown in Figure 25 is made by using two separate wires of different diameters for winding the two different portions, it may be possible to use a single continuous length of wire having different diameters along the respective first and second portions of its length.

Figure 26 illustrates yet another approach to constructing an improved string 99 of the
30 present invention. In this instance the covering 100 is applied in the form of a wrapping using two different wrap angles 101A and 101B on two different portions of the same string.

As should be appreciated from the above description, there are many ways that the strings of the present invention can be modified to provide variable mass per unit length on the main string so as to compensate for the additional mass provided by a partial cover of the
35 present invention. The foregoing embodiments of such variable mass per unit length main strings should serve as some examples of how the present invention may be practiced, but the

present invention is not intended to be limited just to these examples. Accordingly, it is contemplated that the present invention encompasses any string that has a variable mass per unit length along different segments of the string (that is, strings that have one mass per unit length along one segment of the string and a different mass per unit length along another segment of the string).

While particular embodiments of the present invention have been illustrated and described herein, the present invention should not be limited to such illustrations and descriptions. It should be apparent that changes and modifications may be incorporated and embodied as part of the present invention within the scope of the following claims.

5

Table 1

Example #	Construction	First 1/4-Second Response (of Eight 1/4-sec. intervals recorded)					
		Column A		Column B		Column C	
		D string (148 Hz)		A string (108 Hz)		E string (84 Hz)	
		Harmonic	Intensity dB	Harmonic	Intensity dB	Harmonic	Intensity dB
1	3 wrap ePTFE	5	+7	8	+9	4	+3
		6	-4	9	+7	9	+4
		8	+6		none<0		none<0
		9	-5				
2	ePTFE no adhesive	N/A		N/A		5	+10
						8	+13
						12	+10
3	TFE shrink tube (Zeus)	3	+5	N/A		5	+22
		4	+11			7	+21
		5	+13			8	+11
		8	-3			11	+11
		9	+5				none<0
10	+11						
4	TFE tube (loose)	N/A		7	-32	N/A	
				8	-42		
				9	-40		
5	Vinyl electrical tape	N/A		N/A		5	+11
						6	-34
						8	+7
						9	-8
6	Porous UHMWPE	N/A		N/A		5	+4
						6	-7
						8	+10
						9	-4
7 Sample 1	Fender Bass A String nylon wound (commercially available product)	N/A		12	-6	N/A	
				13	-6		
7 Sample 3	Fender Bass A String 4 wrap ePTFE	N/A		4	+4	N/A	
				7	+5		
				9	-3		
				11	+7		
7 Sample 4	Fender Bass A String 6 wrap ePTFE	N/A		7	+4	N/A	
				9	-4		
				11	+6		
				13	+4		

N/A = not applicable (this configuration not tested)

Table 2

Example #	Construction	A string (54 Hz)	
		Harmonic	Intensity dB
<u>7</u> Sample 1	Fender Bass A String, nylon wound as purchased	11	-25
		12	-19
		13	-18
		14	-11
<u>7</u> Sample 3	Fender Bass A String 4 wrap ePTFE	2	+5
		3	+10
		4	+7
		7	+7
		8	-1
<u>7</u> Sample 4	Fender Bass A String 6 wrap ePTFE	12	-1
		2	-3
		3	+13
		4	-3
		8	+16
		10	+12
	12	+13	
	14	+16	

Intonation Test

Table 3

	E string (84 Hz)		
	Sample #A	Sample #B	Sample #C
String Mass (less cover)	7.26g	7.20g	7.03g
Covering Mass	0g	.26g	.26g
Total mass	7.26g	7.46g	7.29g
INTONATION			
3rd Fret	0 cents	0 cents	0 cents
5th Fret	0 cents	0 cents	0 cents
7th Fret	0 cents	+5 cents	0 cents
9th Fret	-5 cents	+10 cents	0 cents
12th Fret	-10 cents	+10 cents	-5 cents

*Note: A plus value indicates note is sharp.
A minus value indicates note is flat.*

- 1 The invention claimed is:
- 1 1. A musical instrument string that comprises:
- 2 a length of main string having variable mass per unit length along its length;
- 3 a cover over a portion of the main string;
- 4 wherein combination of the main string and the cover provides a musical
- 5 instrument string with approximately equal mass per unit length along the length of the string.
- 1 2. The musical instrument string of claim 1 wherein
- 2 the main string has a covered segment and an uncovered segment; and
- 3 the uncovered segment of the main string has greater mass per unit length than
- 4 the covered segment before covering.
- 1 3. The musical instrument string of claim 2 wherein
- 2 the covered segment comprises a main string that has had a portion along the
- 3 length of the main string removed to reduce its mass.
- 1 4. The musical instrument string of claim 2 wherein
- 2 the uncovered segment comprises a main string that has additional material
- 3 added to it to increase its mass.
- 1 5. The musical instrument string of claim 2 wherein
- 2 the main string includes a winding along its length; and
- 3 the covered segment of the main string has a winding spaced apart a greater
- 4 amount than the uncovered segment of the main string in order to decrease its mass.
- 1 6. A musical instrument string, having a length that comprises a variable mass per unit
- 2 length along the length of the string.
- 1 7. The musical instrument string of claim 6 wherein the string includes a cover over at
- 2 least a portion of the string.
- 1 8. The musical instrument string of claim 7 wherein the cover covers a portion of the
- 2 string having reduced mass so as to create a string having approximately equal mass per unit
- 3 length along its entire length.
- 1 9. The musical instrument string of claim 1 wherein the cover avoids extraneous noise
- 2 when the string is played.
- 1 10. The musical instrument of claim 1 wherein
- 2 the string has a longitudinal axis; and
- 3 the cover is deformable parallel to the longitudinal axis of the string so that the
- 4 string maintains its tonal qualities; and
- 5 wherein the cover protects the string against extraneous noise when the string is
- 6 played.

- 1 11. A musical instrument string having a length and comprising:
2 a main string;
3 a cover over the main string, the cover being discontinuous so as to present a first
4 covered segment, an uncovered segment, and a second covered segment.
- 1 12. The musical instrument string of claim 11 wherein the cover includes at least one
2 scored line to facilitate removing a segment of the cover to increase the length of the uncovered
3 segment.
- 1 13. The musical instrument string of claim 11 wherein
2 the string has a longitudinal axis; and
3 the cover is deformable parallel to the longitudinal axis of the string so that the
4 string maintains its tonal qualities; and wherein the cover protects the string against extraneous
5 noise when the string is played.
- 1 14. A musical instrument string having a length and comprising:
2 a main string;
3 a cover over the main string, the cover including at least one score line
4 therein to facilitate removal of a portion of the cover from the main string.
- 1 15. The musical instrument string of claim 14 wherein
2 the string has a longitudinal axis; and
3 the cover is deformable parallel to the longitudinal axis of the string so that the
4 string maintains its tonal qualities; and wherein the cover protects the string against extraneous
5 noise when the string is played.
- 1 16. A musical instrument string comprising
2 a length of main string;
3 a cover over a portion of the main string, the cover protecting the string from
4 contamination while not dampening the sound of the string;
5 wherein the cover and main string combine to present an essentially consistent
6 mass per unit length along the length of the main string; and
7 wherein the cover protects against extraneous noise when the string is played.
- 1 17. A musical instrument string comprising
2 a main string,
3 a cover wrapped around the main string;
4 wherein the cover is wrapped at a first wrap angle along a first portion of the
5 string and the cover is wrapped at a second, different, wrap angle along a second portion of the
6 string.
- 1 18. The musical instrument string of claim 17 wherein

2 the string is adapted for use on a guitar having a fret board region and a
3 strumming region;

4 the first portion of the string having the first wrap angle corresponds to the fret
5 board region of the guitar;

6 and the second portion of the string having the second wrap angle corresponds to
7 the strumming region of the guitar.

1 19. A guitar string having a length comprising

2 a main string;

3 a cover over the main string, the main string and the cover combining to provide
4 essentially uniform mass per unit length over the length of the guitar string;

5 wherein the string when mounted on a guitar produces correct intonation through
6 at least the ninth fret.

1 20. A string for a musical instrument that comprises

2 a musical instrument string having a polymeric covering over at least a portion of
3 its length,

4 wherein when played on a musical instrument, the musical instrument string
5 having a polymeric covering produces a sound amplitude, considered to be the sum of the
6 amplitudes of the first ten harmonics measured during the first quarter second of sound
7 produced by playing, that is greater than or equal to the sound amplitude of the musical
8 instrument string without the polymeric covering when played in the same way on the musical
9 instrument.

1 21. A string according to claim 20 wherein the musical instrument string is a wound
2 string.

1 22. A string according to claim 20 wherein the polymeric covering is selected from the
2 group consisting of fluorinated ethylene propylene, perfluoro alkoxy, polytetrafluoroethylene,
3 polyethylene, polypropylene, polyamide, polyimide, polyurethane and polyester.

1 23. A string according to claim 20 wherein the polymeric covering is an adhered
2 polymeric covering.

1 24. A string according to claim 20 wherein the polymeric covering extends over
2 essentially the entire string.

1 25. A string according to claim 20 wherein the polymeric covering is a continuous
2 polymeric covering over at least a portion of the string.

1 26. A string for a string musical instrument that comprises
2 a wound string including a winding and having a longitudinal axis;
3 a cover around the wound string, the cover comprising at least
4 one layer of polymer, the polymer being deformable along the longitudinal axis of
5 the string.

1 27. The string of claim 26 wherein the polymer comprises an expanded
2 polytetrafluoroethylene (PTFE), the PTFE being expanded in at least a
3 longitudinal direction to produce a microscopic structure including polymeric
4 fibrils.

1 28. The string of claim 26 wherein the polymer comprises a porous
2 polytetrafluoroethylene.

1 29. The string of claim 26 wherein the cover is attached with an
2 adhesive.

1 30. The string of claim 26 wherein the cover is attached to the wound
2 string with a discontinuous layer of adhesive.

1 31. The string of claim 26 wherein the cover is attached to the wound
2 string with a continuous layer of adhesive.

1 32. The string of claim 26 wherein
2 the cover is relatively non-deformable in a longitudinal direction
3 and relatively deformable in a transverse direction; and
4 the cover is wrapped around the wound string with the longitudinal
5 direction of the cover oriented at an angle to the longitudinal axis of the wound
6 string.

1 33. The string of claim 32 wherein
2 the cover is attached to the wound string with a discontinuous
3 layer of adhesive, the transverse deformability of the cover and the discontinuous
4 layer of adhesive combine to allow movement of the winding parallel to the
5 longitudinal axis of the wound string.

1 34. The string of claim 32 wherein
2 the cover is attached to the wound string with a continuous layer
3 of adhesive, the transverse deformability of the cover and the continuous layer
4 of adhesive combine to allow movement of the winding parallel to the
5 longitudinal axis of the wound string.

1 35. The string of claim 27 wherein the cover comprises at least two
2 layers of expanded PTFE, with the two layers at different angles with respect to
3 the longitudinal axis.

1 36. The string of claim 35 wherein
2 each of the layers of expanded PTFE is bonded to at least one
3 other PTFE layer;

4 the layer of expanded PTFE closest to the wound string is
5 attached to the wound string with a layer of adhesive that will deform to allow
6 movement of the winding parallel to the longitudinal axis of the wound string.

1 37. The string of claim 36 wherein the layer of adhesive comprises a
2 discontinuous layer of adhesive.

1 38. The string of claim 27 wherein the cover comprises at least two
2 layers of expanded PTFE, each layer wrapped approximately parallel to the
3 other.

1 39. The string of claim 36 wherein the layer of adhesive comprises a
2 continuous layer of adhesive.

1 40. The string of claim 26 wherein the cover includes a coating adhered
2 to an outside surface of at least one polymer layer of the polymer.

1 41. The string of claim 26 wherein
2 the string is adapted to be mounted on a musical instrument
3 having a fingering board; and
4 the cover is attached only over a portion of the string adapted to
5 be installed over the fingering board.

1 42. The string of claim 26 wherein the cover comprises a surface that
2 serves to avoid extraneous noise from the string during play.

1 43. The string of claim 26 wherein the cover comprises a smooth
2 surface that serves to protect a musician's fingers from abrasion during play.

1 44. The string of claim 26 wherein the cover extends over essentially
2 the entire string.

1 45. An improved string for a string instrument that comprises
2 a wound string having a longitudinal axis, a core, and winding
3 wrapped around the core;
4 a polymeric cover wrapped around the wound string, the
5 polymeric cover being formed from a material being relatively non-deformable in
6 a longitudinal direction and relatively deformable in a transverse direction, the

7 cover being wrapped around the wound string with the longitudinal direction of
8 the cover oriented at an angle to the longitudinal axis of the wound string; and
9 an adhesive layer bonding the polymeric cover to the wound
10 string, the adhesive layer preventing separation of the cover from the wound
11 string while combining with the cover to allow movement of the windings parallel
12 to the longitudinal axis of the wound string.

1 46. The string of claim 45 wherein the adhesive layer comprises a
2 discontinuous layer of adhesive between the cover and the wound string.

1 47. The string of claim 45 wherein the adhesive layer comprises a
2 continuous layer of adhesive between the cover and the wound string.

1 48. The string of claim 45 wherein the polymeric cover comprises
2 multiple layers of polymer.

1 49. The string of claim 48 wherein the multiple layers of polymer are
2 oriented at an angle to each other and bonded together.

1 50. The string of claim 48 wherein the multiple layers of polymer are
2 oriented approximately parallel to each other.

1 51. The string of claim 45 wherein the polymer cover comprises an
2 expanded polytetrafluoroethylene (PTFE), the PTFE being expanded in its
3 longitudinal direction to produce a microscopic structure comprising polymeric
4 fibrils.

1 52. The string of claim 51 wherein the cover includes a layer of polymer
2 adhered to the outside of the expanded PTFE.

1 53. The string of claim 45 wherein the adhesive is selected from the
2 group consisting of polyurethane, FEP, and PFA.

1 54. A string for a string musical instrument that comprises:

2 a wound string having a longitudinal axis, core, and winding
3 wrapped around the core;

4 a cover on the wound string comprising an adhered polymer film
5 allowing movement of the windings parallel to the longitudinal axis of the wound
6 string while protecting the string from contamination.

1 55. The string of claim 54 wherein the polymer film is selected from the
2 group consisting of FEP, PFA, PTFE, polyethylene, polypropylene, polyamide,
3 polyimide, polyurethane, and polyester.

1 56. A string for a musical instrument that comprises a wound string
2 having a core and a winding wrapped around the core, said winding having an

3 exterior surface and an adhered polymer coating on the exterior surface of the
4 wound string.

1 57. The string of claim 56 wherein the polymer coating is selected from
2 the group consisting of FEP, PFA, PTFE, polyethylene, polypropylene,
3 polyamide, polyimide, polyurethane, and polyester.

1 58. A string for a string musical instrument that comprises a string
2 having an exterior surface wherein at least a substantial portion of said exterior
3 surface is provided with an adhered polymer coating.

1 59. The string of claim 58 wherein the polymer coating is selected from
2 the group consisting of FEP, PFA, PTFE, polyethylene, polypropylene,
3 polyamide, polyimide, polyurethane, and polyester.

1 60. A string for a string musical instrument that comprises a string
2 having a length wherein the string is provided with a polymer covering that is
3 continuous along at least a portion of the length of the string.

1 61. The string of claim 60 wherein the polymer covering is selected
2 from the group consisting of FEP, PFA, PTFE, polyethylene, polypropylene,
3 polyamide, polyimide, polyurethane, and polyester.

1 62. The string of claim 60 wherein
2 the string is adapted to be mounted on a musical instrument
3 having a fingering board; and
4 the cover is attached only over a portion of the string adapted to
5 be installed over the fingering board.

1 63. The string of claim 60 wherein the cover comprises a surface that
2 serves to avoid extraneous noise from the string during play.

1 64. The string of claim 60 wherein the cover comprises a smooth
2 surface that serves to protect a musician's fingers from abrasion during play.

1 65. The string of claim 60 wherein the cover extends over essentially
2 the entire string.

1 66. A musical instrument strung with strings of different pitches that
2 comprises:

3 a first string of a first pitch covered with a first polymer covering
4 along at least a portion of its length; and

5 a second string of a second pitch covered with a second
6 polymer covering along a portion of its length;

7 wherein the first and second polymer covering serve to protect
8 the strings while maintaining tonal quality of the strings.

1 67. A musical instrument string made by the process comprising:
2 providing a string having a longitudinal axis;
3 covering the string with a cover, the cover being deformable
4 along the longitudinal axis of the string; and
5 attaching the cover to the string so that the cover remains
6 affixed to the string during play.

1 68. The musical instrument string made in accordance with claim 67
2 that further comprises forming the cover with at least layers of polymer
3 material.

1 69. The musical instrument string made in accordance with claim 67
2 that further comprises attaching the cover to the string with an adhesive.

1 70. A musical instrument string made by the process comprising:
2 providing a string having a longitudinal axis;
3 covering the string with a cover; and
4 attaching the cover to the string so that the cover remains
5 affixed to the string during play;
6 wherein the cover is substantially non-dampening.

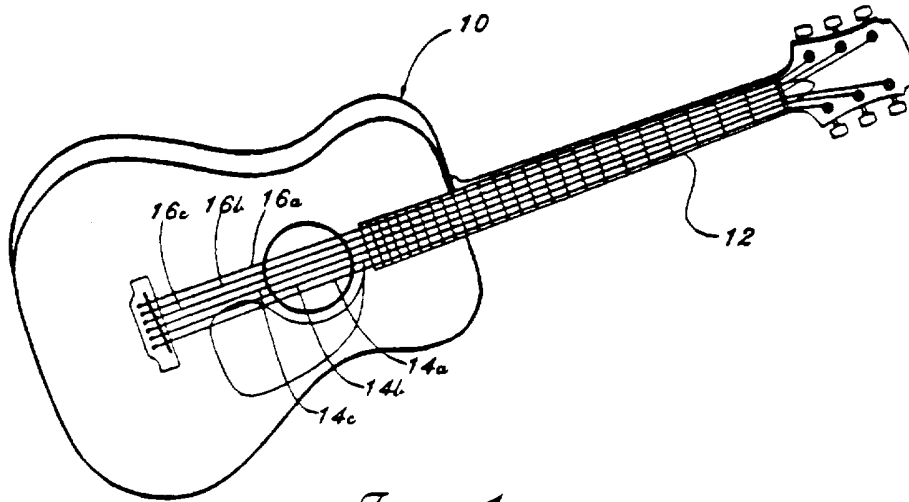

Fig. 1

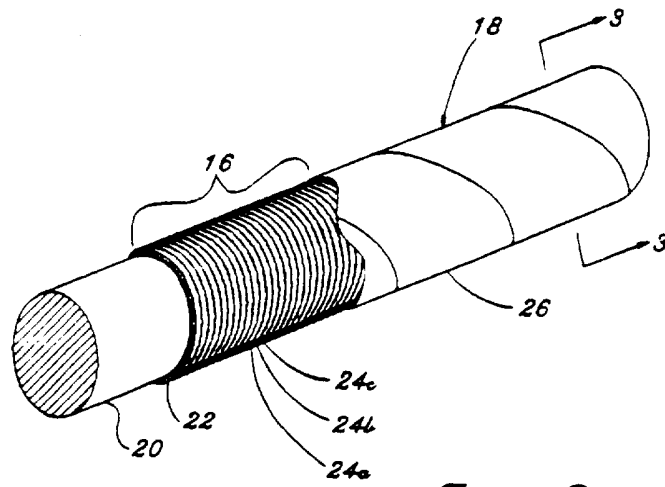

Fig. 2

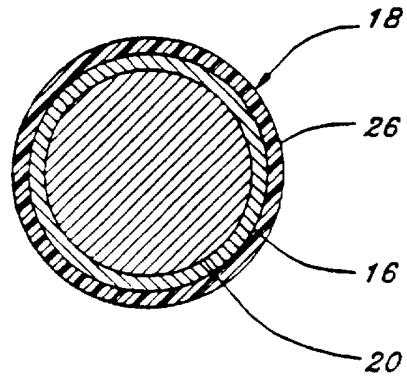

Fig. 3

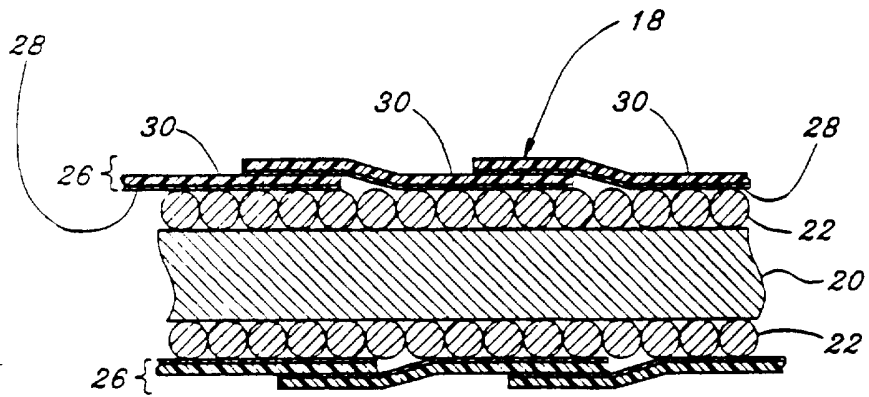

Fig. 4

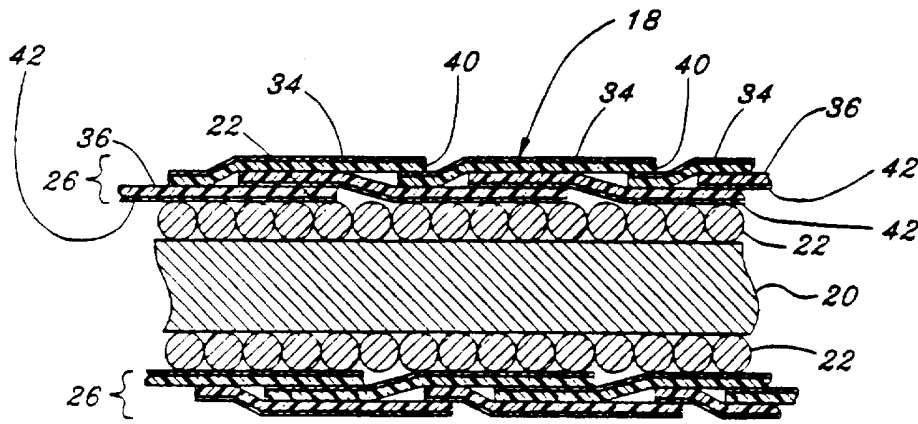

Fig. 5

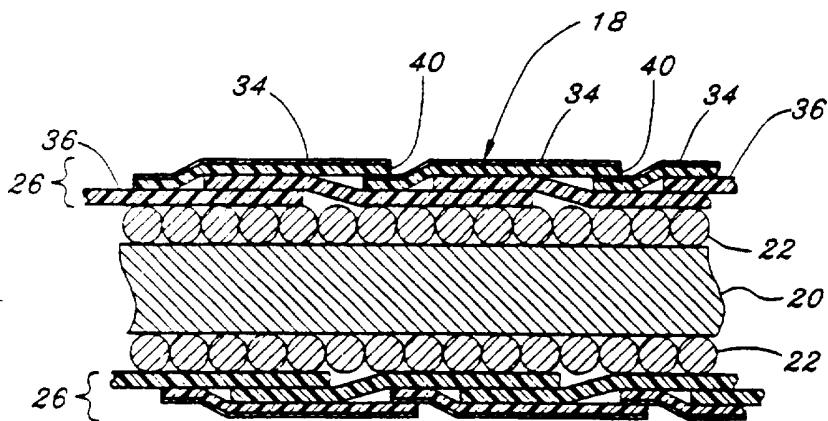

Fig. 6

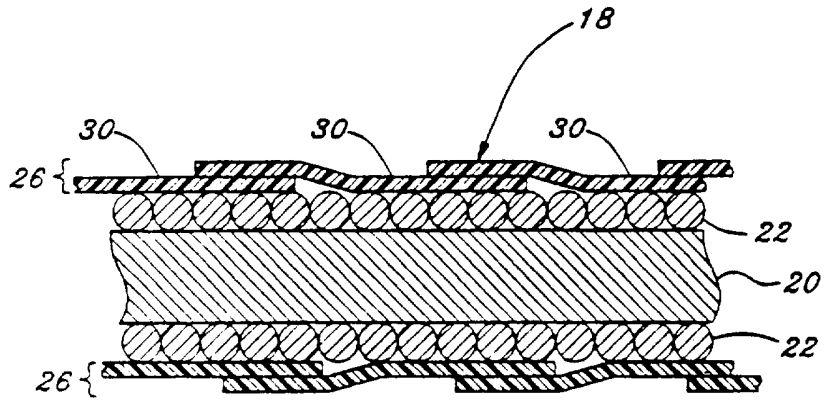

Fig. 7

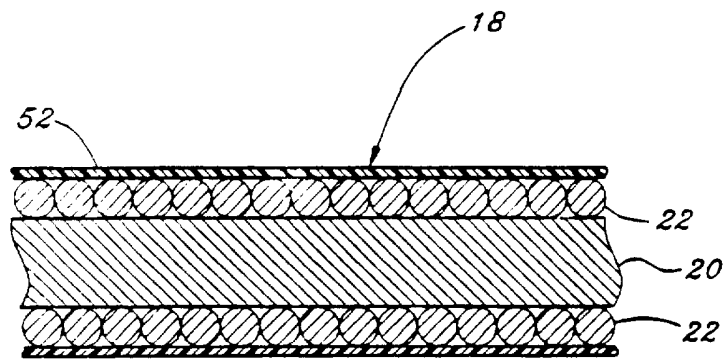

Fig. 8

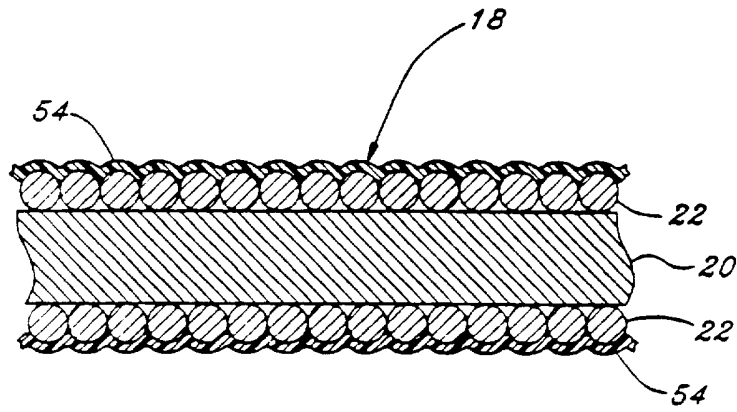

Fig. 9

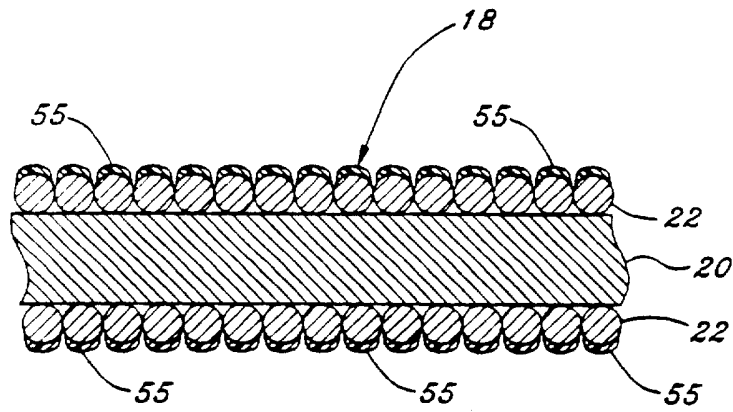

Fig. 10

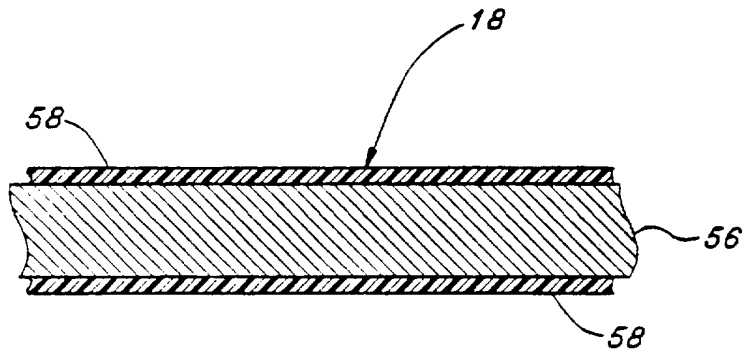

Fig. 11

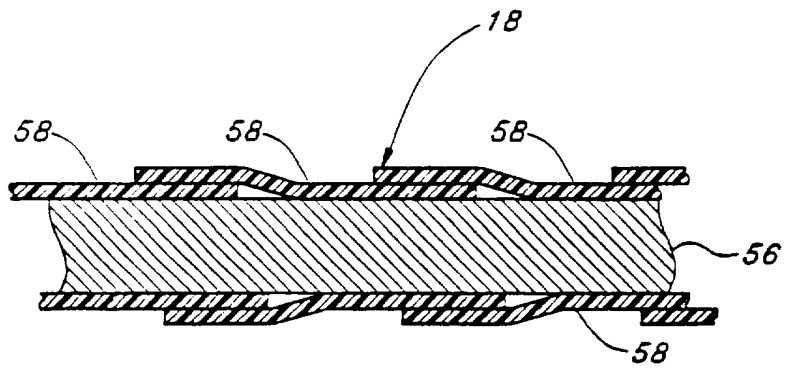

Fig. 12

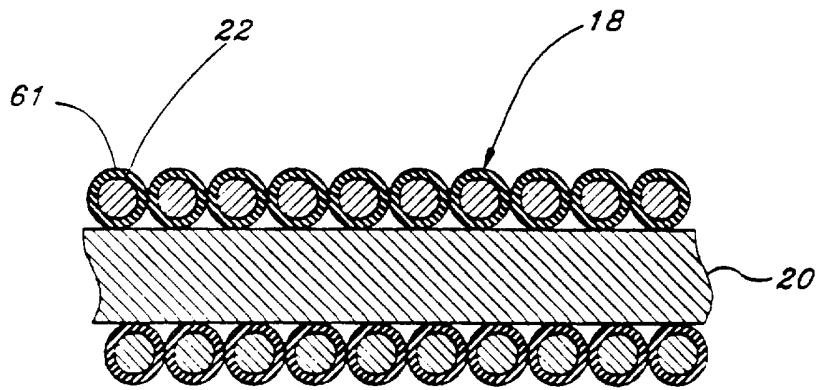

Fig. 13

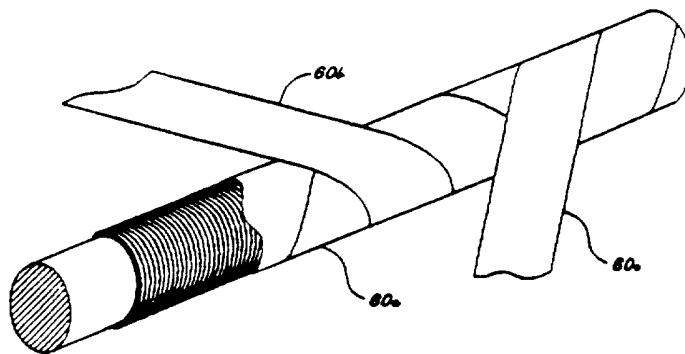

Fig. 14

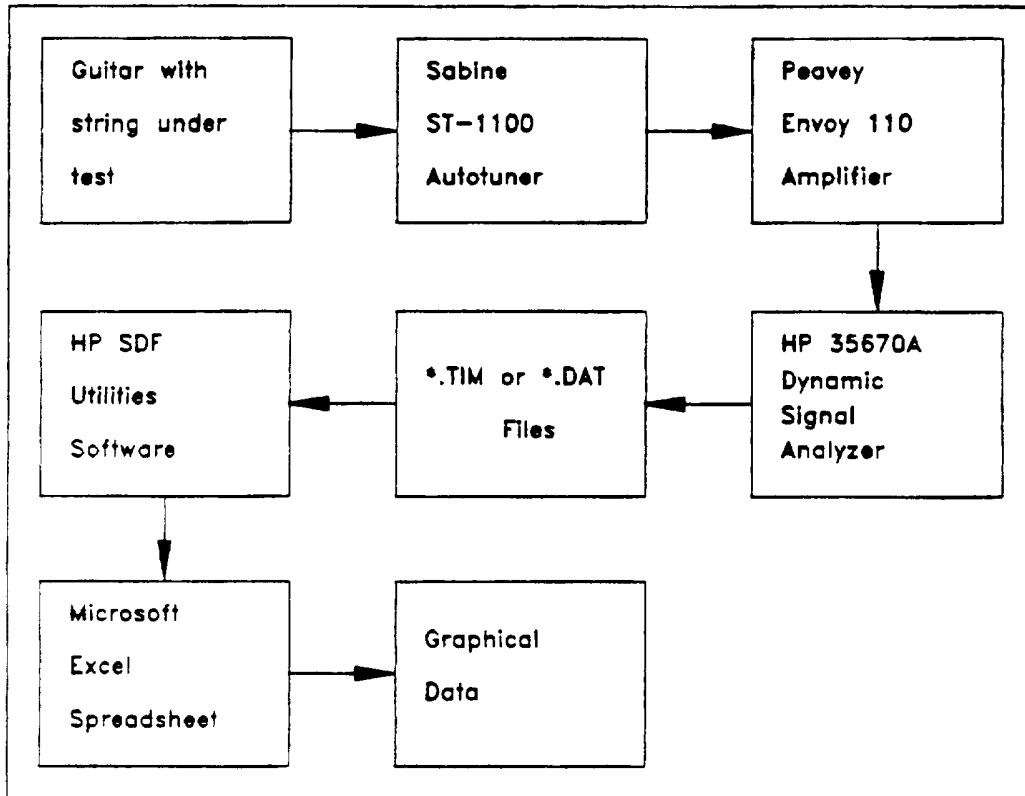

Fig. 15

9/14

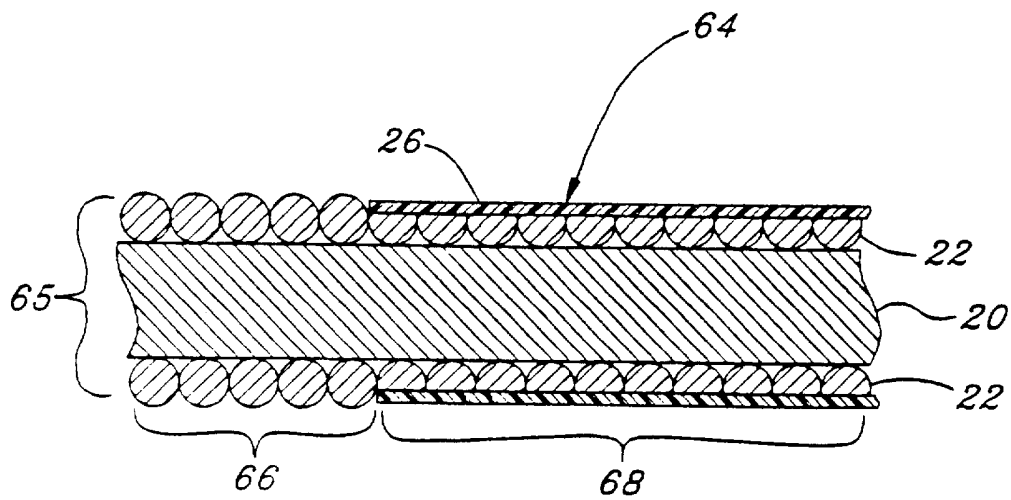

Fig. 16

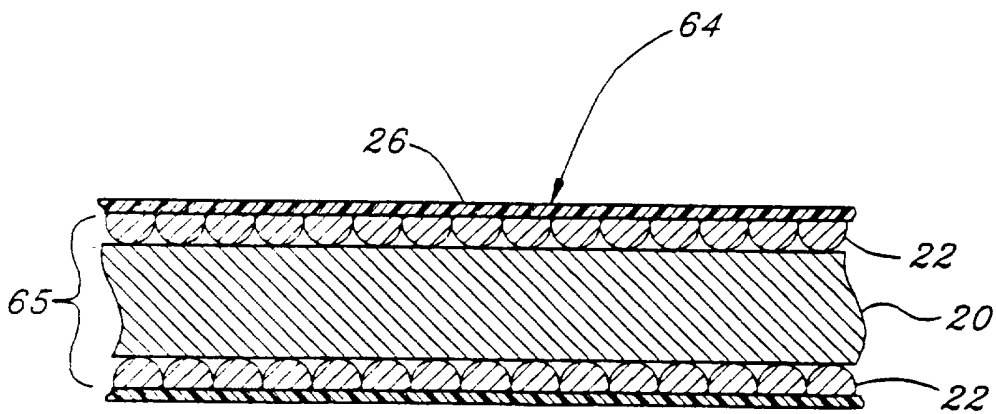

Fig. 17

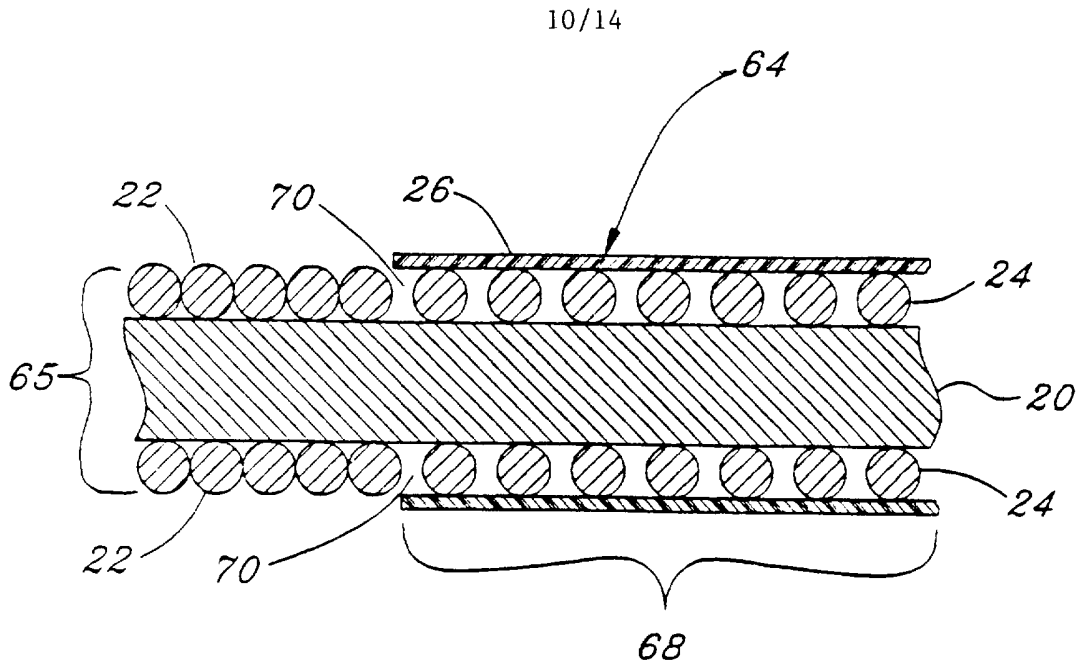

Fig. 18

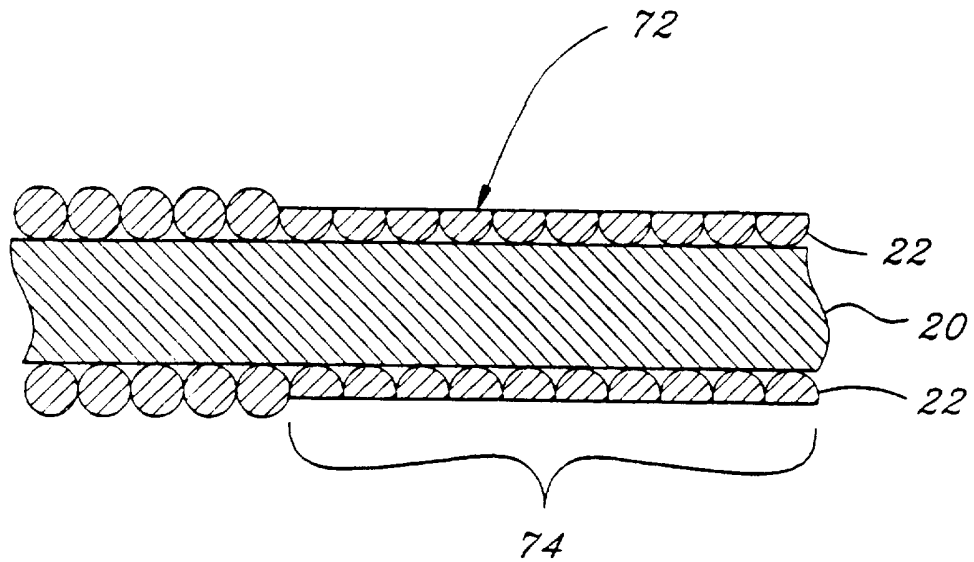

Fig. 19

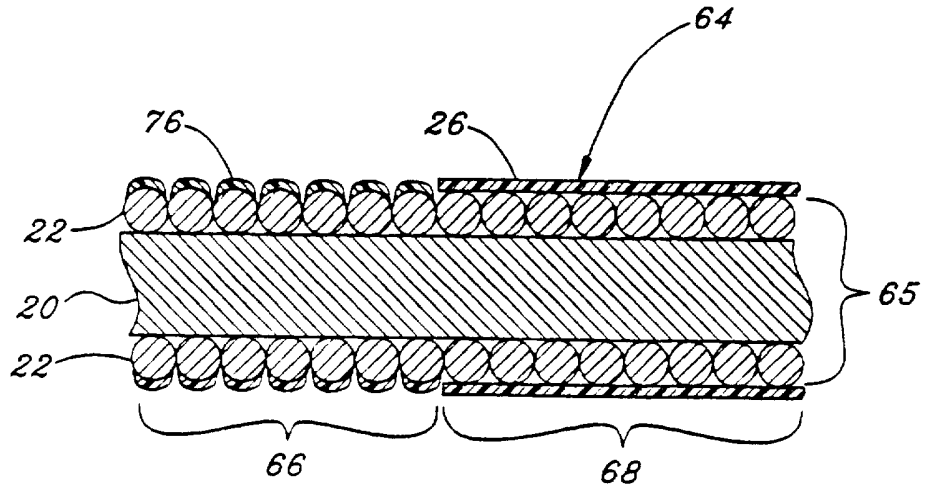

Fig. 20

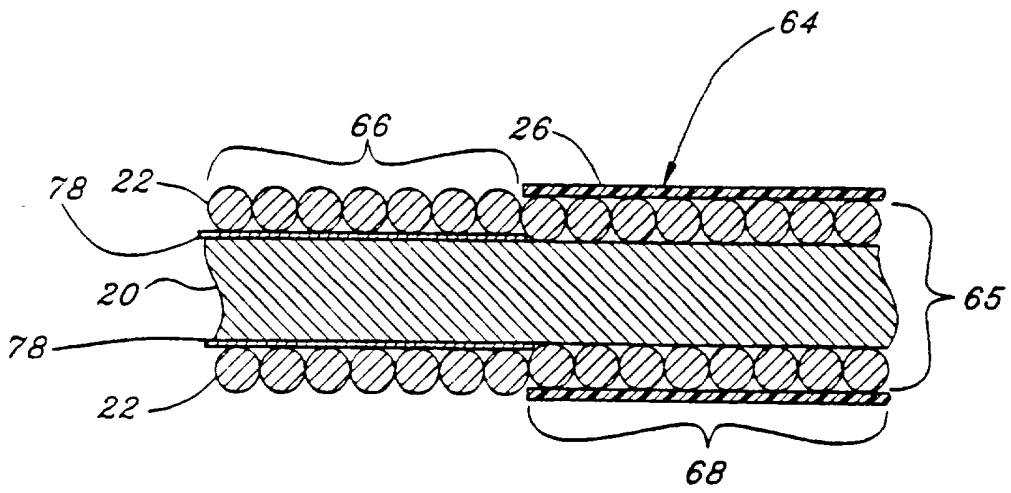

Fig. 21

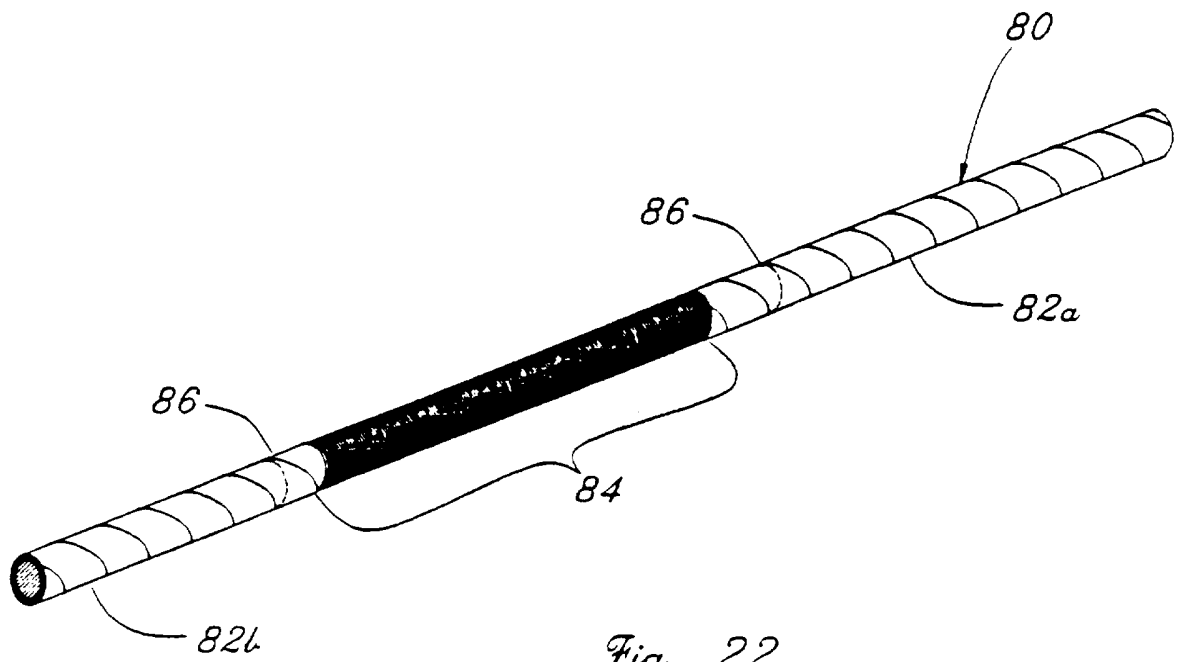

Fig. 22

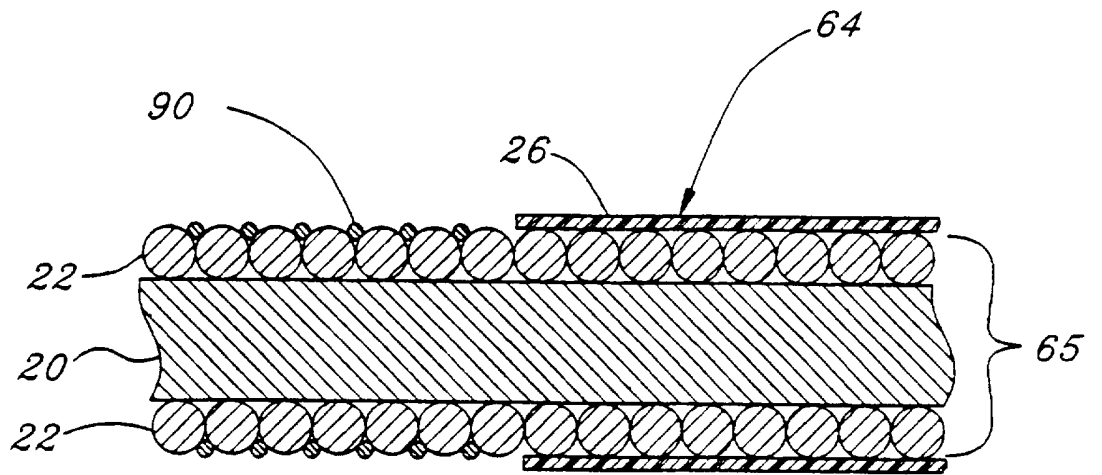

Fig. 23

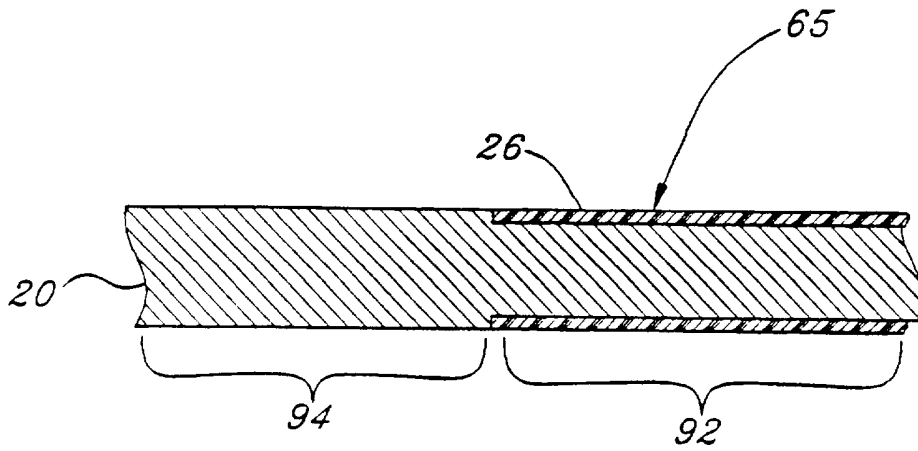

Fig. 24

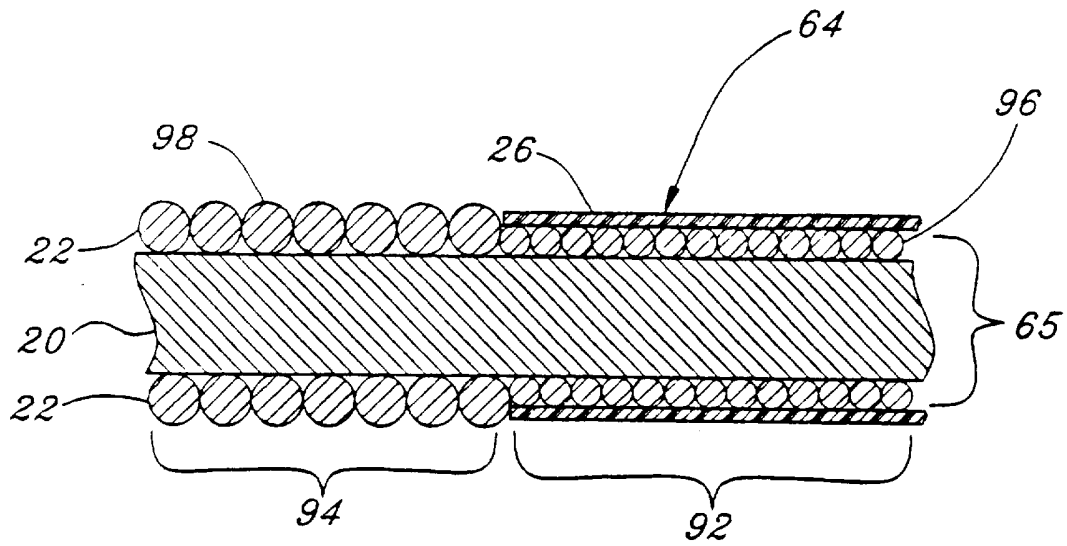

Fig. 25

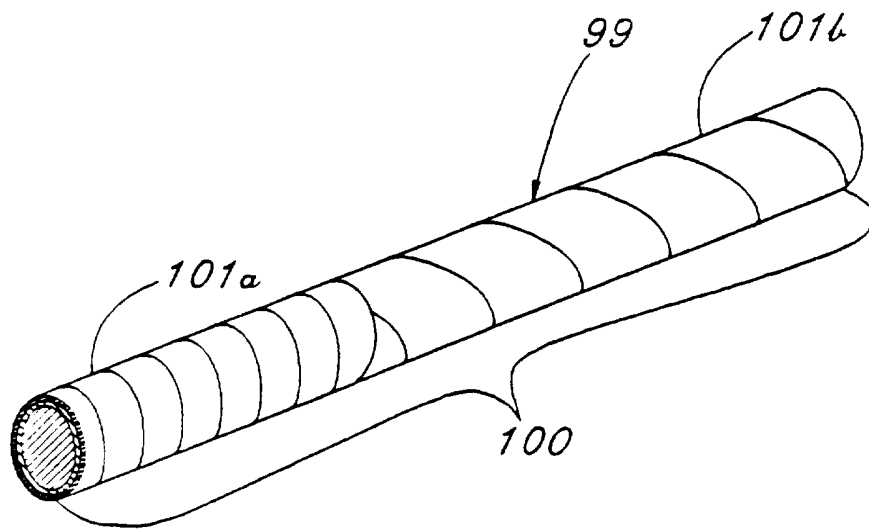

Fig. 26

INTERNATIONAL SEARCH REPORT

International Application No
PCT/US 96/15113

A. CLASSIFICATION OF SUBJECT MATTER IPC 6 G10D3/10				
According to International Patent Classification (IPC) or to both national classification and IPC				
B. FIELDS SEARCHED Minimum documentation searched (classification system followed by classification symbols) IPC 6 G10D				
Documentation searched other than minimum documentation to the extent that such documents are included in the fields searched				
Electronic data base consulted during the international search (name of data base and, where practical, search terms used)				
C. DOCUMENTS CONSIDERED TO BE RELEVANT				
Category *	Citation of document, with indication, where appropriate, of the relevant passages	Relevant to claim No.		
X	DE,A,41 09 334 (ALADIN ALEXANDER ;ALADIN MAZHUL IRINA (DE); SCHMIDT BERND DR RER N) 12 November 1992	16,26, 32, 42-44, 54,55		
Y A	see abstract; claims 1,4,6 see page 10, line 8 - line 17 see page 14, line 16 - page 15, line 5 ---	1,6,7 19-22, 24,45		
Y	DE,A,33 26 006 (IGNATIUS GEORG) 31 January 1985 see column 1, line 23 - line 44 see column 1, line 56 - line 14; claims 1,3; figure 1 --- -/--	1,6,7		
<input checked="" type="checkbox"/> Further documents are listed in the continuation of box C. <input checked="" type="checkbox"/> Patent family members are listed in annex.				
* Special categories of cited documents :				
<table style="width: 100%; border: none;"> <tr> <td style="width: 50%; border: none; vertical-align: top;"> *A* document defining the general state of the art which is not considered to be of particular relevance *E* earlier document but published on or after the international filing date *L* document which may throw doubts on priority claim(s) or which is cited to establish the publication date of another citation or other special reason (as specified) *O* document referring to an oral disclosure, use, exhibition or other means *P* document published prior to the international filing date but later than the priority date claimed </td> <td style="width: 50%; border: none; vertical-align: top;"> *T* later document published after the international filing date or priority date and not in conflict with the application but cited to understand the principle or theory underlying the invention *X* document of particular relevance; the claimed invention cannot be considered novel or cannot be considered to involve an inventive step when the document is taken alone *Y* document of particular relevance; the claimed invention cannot be considered to involve an inventive step when the document is combined with one or more other such documents, such combination being obvious to a person skilled in the art. *&* document member of the same patent family </td> </tr> </table>			*A* document defining the general state of the art which is not considered to be of particular relevance *E* earlier document but published on or after the international filing date *L* document which may throw doubts on priority claim(s) or which is cited to establish the publication date of another citation or other special reason (as specified) *O* document referring to an oral disclosure, use, exhibition or other means *P* document published prior to the international filing date but later than the priority date claimed	*T* later document published after the international filing date or priority date and not in conflict with the application but cited to understand the principle or theory underlying the invention *X* document of particular relevance; the claimed invention cannot be considered novel or cannot be considered to involve an inventive step when the document is taken alone *Y* document of particular relevance; the claimed invention cannot be considered to involve an inventive step when the document is combined with one or more other such documents, such combination being obvious to a person skilled in the art. *&* document member of the same patent family
A document defining the general state of the art which is not considered to be of particular relevance *E* earlier document but published on or after the international filing date *L* document which may throw doubts on priority claim(s) or which is cited to establish the publication date of another citation or other special reason (as specified) *O* document referring to an oral disclosure, use, exhibition or other means *P* document published prior to the international filing date but later than the priority date claimed	*T* later document published after the international filing date or priority date and not in conflict with the application but cited to understand the principle or theory underlying the invention *X* document of particular relevance; the claimed invention cannot be considered novel or cannot be considered to involve an inventive step when the document is taken alone *Y* document of particular relevance; the claimed invention cannot be considered to involve an inventive step when the document is combined with one or more other such documents, such combination being obvious to a person skilled in the art. *&* document member of the same patent family			
1 Date of the actual completion of the international search	Date of mailing of the international search report			
15 January 1997	22.01.97			
Name and mailing address of the ISA European Patent Office, P.B. 5818 Patentlaan 2 NL - 2280 HV Rijswijk Tel. (+ 31-70) 340-2040, Tx. 31 651 epo nl, Fax: (+ 31-70) 340-3016		Authorized officer Haasbroek, J		

INTERNATIONAL SEARCH REPORT

Intern. Application No.

PCT/US 96/15113

C.(Continuation) DOCUMENTS CONSIDERED TO BE RELEVANT		
Category *	Citation of document, with indication, where appropriate, of the relevant passages	Relevant to claim No.
X	WO,A,90 01766 (JOIE JEAN LUC ;FOUSSARD FRANCOIS (FR)) 22 February 1990	16, 19-22, 24-26, 60,61, 63-67,70 1,10
A	see abstract; figure 3 see page 2, line 23 - line 35 see page 4, line 14 - page 5, line 6 see page 9, line 5 - line 20 ---	
A	DE,C,963 830 (K.WEIDLER) 16 May 1957 see claim 1; figure 1 ---	26,29,31
A	US,A,4 326 444 (MARKLEY DONALD D) 27 April 1982 see abstract; figure 1 -----	1

INTERNATIONAL SEARCH REPORT

information on patent family members

International Application No

PCT/US 96/15113

Patent document cited in search report	Publication date	Patent family member(s)	Publication date
DE-A-4109334	12-11-92	NONE	
DE-A-3326006	31-01-85	DE-D- 3486300	19-05-94
		EP-A- 0137924	24-04-85
		US-A- 5585579	17-12-96
WO-A-9001766	22-02-90	FR-A- 2635400	16-02-90
DE-C-963830		NONE	
US-A-4326444	27-04-82	NONE	