

(No Model.)

3 Sheets—Sheet 1.

W. R. LOW.

FOLLOWER FOR RAM ELEVATORS.

No. 288,352.

Patented Nov. 13, 1883.

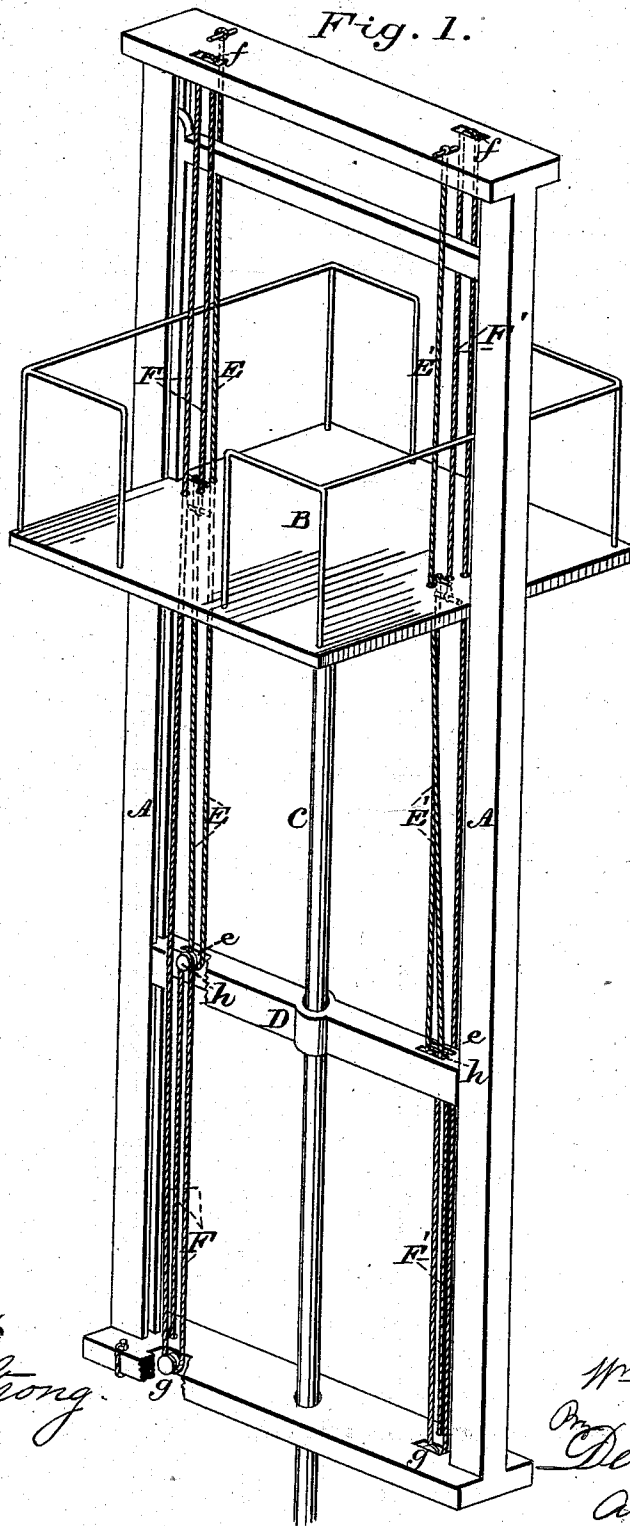

Witnesses,  
Geo. H. Strong  
J. S. Brown

Inventor  
Wm. R. Low  
By Dewey & Co.  
Attorneys

(No Model.)

3 Sheets—Sheet 2.

W. R. LOW.

FOLLOWER FOR RAM ELEVATORS.

No. 288,352.

Patented Nov. 13, 1883.

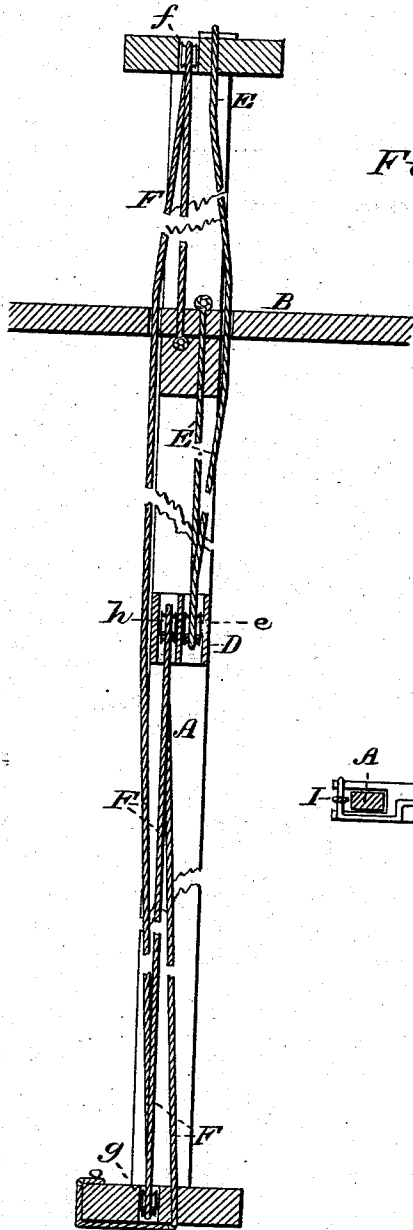

Fig. 2.

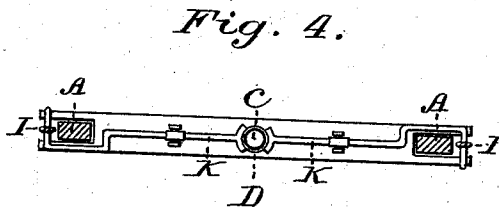

Fig. 4.

Witnesses,  
Geo. H. Strong  
J. Brown

Inventor,  
Wm. R. Low  
By Dewey & Co.  
Attorneys

(No Model.)

3 Sheets—Sheet 3.

W. R. LOW.

FOLLOWER FOR RAM ELEVATORS.

No. 288,352.

Patented Nov. 13, 1883.

Fig. 3.

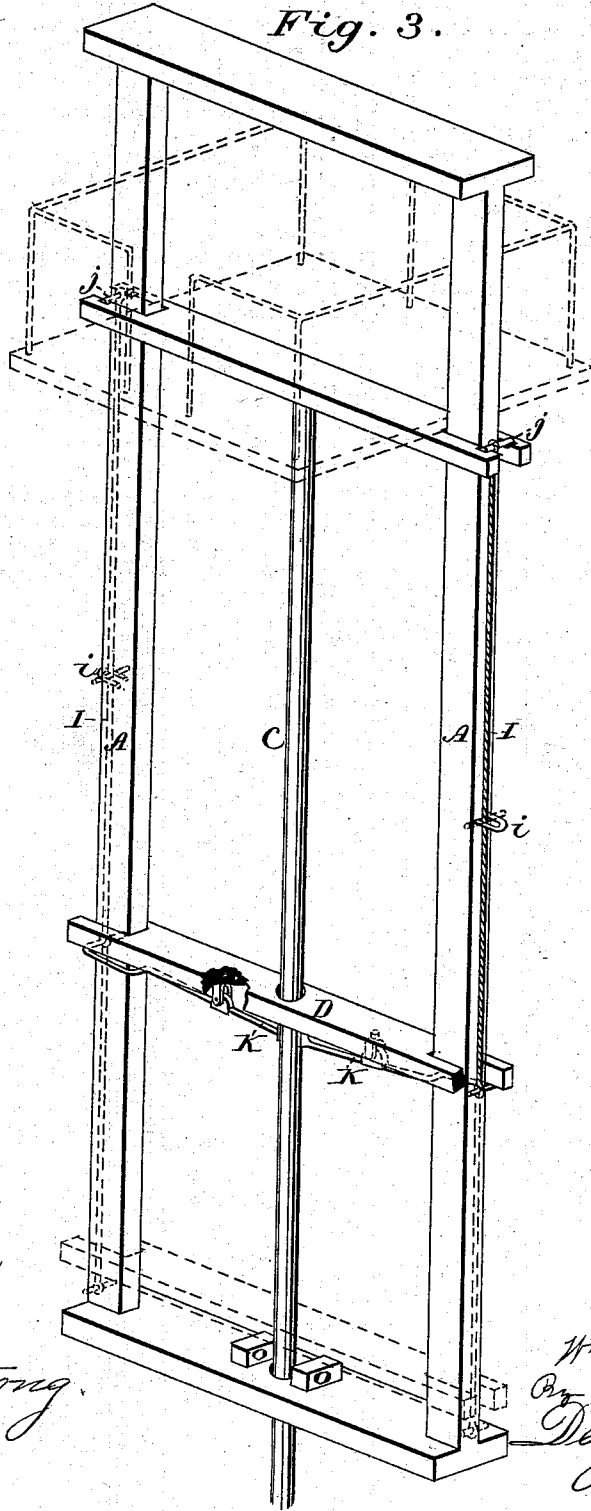

Witnesses,  
Geo. H. Strong  
James

Inventor,  
Wm. R. Low  
By  
Dewey & Co.  
Attorneys

# UNITED STATES PATENT OFFICE.

WILLIAM R. LOW, OF SAN FRANCISCO, CALIFORNIA.

## FOLLOWER FOR RAM-ELEVATORS.

SPECIFICATION forming part of Letters Patent No. 288,352, dated November 13, 1883.

Application filed November 13, 1882. (No model.)

*To all whom it may concern:*

Be it known that I, WILLIAM R. LOW, of the city and county of San Francisco, State of California, have invented an Improved Follower for Elevator-Rams; and I hereby declare the following to be a full, clear, and exact description thereof.

My invention relates to certain improvements in elevators, and more especially to that class in which the cage or car is elevated by what are known as "ram-elevators," provided with follower-guides for steadying the ram-spindle; and it consists in certain details of construction, as hereinafter fully described, and specifically pointed out in the claims.

The particular means by which I accomplish these movements I will now illustrate by reference to the accompanying drawings, in which—

Figure 1 is a perspective view of my follower, showing a means by which it is enabled to afford support to the ram at a point midway. Fig. 2 is a vertical section, showing ropes E and F—the means for accomplishing the object. Fig. 3 is a view of my follower, showing a means for causing its movement at any point. Fig. 4 is a plan, looking up, of the follower and clamp shown in Fig. 3.

The movement which I deem the best I will explain first. As the car ascends and the ram lengthens it is obvious that the point needing greatest support constantly changes, as this point is about midway between the base of the shaft and the car, wherever the latter may be. To afford support at this changeable point I have but to so connect my follower that it shall move only one-half as fast as the car.

Let A represent the side guide-timbers in the elevator-shaft, in which the cage or car B is adapted to ascend and descend by means of the vertical ram C, the top of which is bolted under the car, and is elevated from below by the ordinary hydraulic power.

Between the side guides, A, and below the car, is a transverse piece or follower, D, through which the ram loosely passes, and which is adapted to travel up or down between the guides readily.

To the bottom of the car, at its sides, are secured wires, cords, or ropes E E'. These pass down to the follower D and around pul-

leys e e upon it, and up again through the car to the top of the shaft, where they are secured to the frame-timbers. By this connection of the follower with the car the former will travel only one-half as fast as the latter, and will consequently always be midway between the bottom of the shaft and the car. It begins to move with the car, and will afford support to the ram at the middle point of its exposed portion, no matter where the car may be. These ropes raise the follower, and if every part were accurate it would descend of its own weight; but it is likely that the lateral strain upon the ram would cause the follower to bind. I have therefore further connected it with the car to make its descent positive.

To opposite sides of the car are attached ropes F F'. These pass up to the top of the frame-timbers and around pulleys f therein, down through the car and follower to the base of the elevator-shaft, around pulleys g, up to the follower and around pulleys h upon said follower, down again to the base, where they are secured. These ropes pull the follower down with accuracy. The constant movement given to the follower here shown, while especially applicable to tall buildings, might not always be required. It might be sufficient in some cases to pick the follower up at any given point, and then to move it at the same rate of speed as the car, to afford support at the point desired. I show this arrangement in Fig. 3, where similar letters indicate similar parts as those heretofore described. The object here is to have the follower at rest until the car has reached a certain point—say half its journey—and then to start it, to thereafter afford support to the ram.

I represents ropes connected with the ends of the follower, and extending up behind the side timbers to a point about half-way, where they pass through staples i, in which they are secured by a cross piece or rod, j, secured to their ends. The frame-timbers of the car extend on each side of the side guides, A, and are slotted, as shown, so that when the car reaches the staples it picks up the cross-pieces j and carries the follower up with it for the remainder of the distance. To insure its descent, I have the clamps K pivoted under the follower. Their inner ends are adapted to

impinge upon the ram and their outer ends have secured to them the ropes I. When the car picks up the ropes, they draw up on the outer ends of the clamps, and thus cause their inner ends to clamp or grip the ram. This grip they maintain in the descent of the follower, and thus insure its downward movement with the ram. Small stops *o* at the base of the elevator-shaft free the clamps from the ram when the follower reaches the bottom.

By similar connections to those here shown, it is obvious that I could have more than one follower, and pick each up at any desired point or points.

Having thus described my invention, what I claim as new, and desire to secure by Letters Patent, is—

1. In combination with the vertically-moving car and ram of an elevating apparatus, the follower or guide D, fitted loosely upon the ram between the side timbers, A, and a means for causing said follower to travel up and down the elevator-shaft at one-half the rate of speed of the moving car, whereby said ram may be braced and steadied at a point midway between the base of the shaft and the car, substantially as herein described.

2. In combination with the vertically-moving car B and ram C, the follower or guide D, fitted loosely upon the ram between the side timbers, A, and the means for raising said follower at one-half the speed of the moving car, consisting of the ropes E E', attached to the follower and car, and arranged in the manner shown, substantially as herein described.

3. In combination with the vertically-mov-

ing car B and ram C, the follower or guide D, fitted loosely upon the ram between the side timbers, A, the ropes E E', connected with the follower and car, and arranged, as shown, to elevate the follower, as described, and the ropes F F', arranged as shown, to carry it down again, substantially as and for the purpose herein described.

4. In combination with the vertically-moving car and ram of an elevating apparatus, the follower or guide D, having the pivoted clamps K, the inner ends of which are adapted to bind upon the ram, and suitable cords, wires, or ropes connecting the car with the outer ends of the clamps, whereby said clamps are made to bind upon the ram and elevate and lower the follower, substantially as described.

5. In combination with the vertically-moving car and ram of an elevating apparatus, the follower D, having the pivoted clamps K, and the means for raising and lowering the follower and causing the clamps to bind upon the ram, consisting of the ropes I, connected with the outer ends of the clamps at their lower ends, and having cross-pieces *j* at their upper ends supported in staples on the sides of the shaft-frame, and adapted to be picked up by the moving car, substantially as herein described.

In witness whereof I hereunto set my hand.

WILLIAM R. LOW.

Witnesses:

SOUTHARD HOFFMAN,  
J. S. MANLEY.