

April 21, 1942.

G. F. HANDLEY
TYPEWRITING MACHINE

2,280,702

Filed Jan. 18, 1941

2 Sheets—Sheet 2

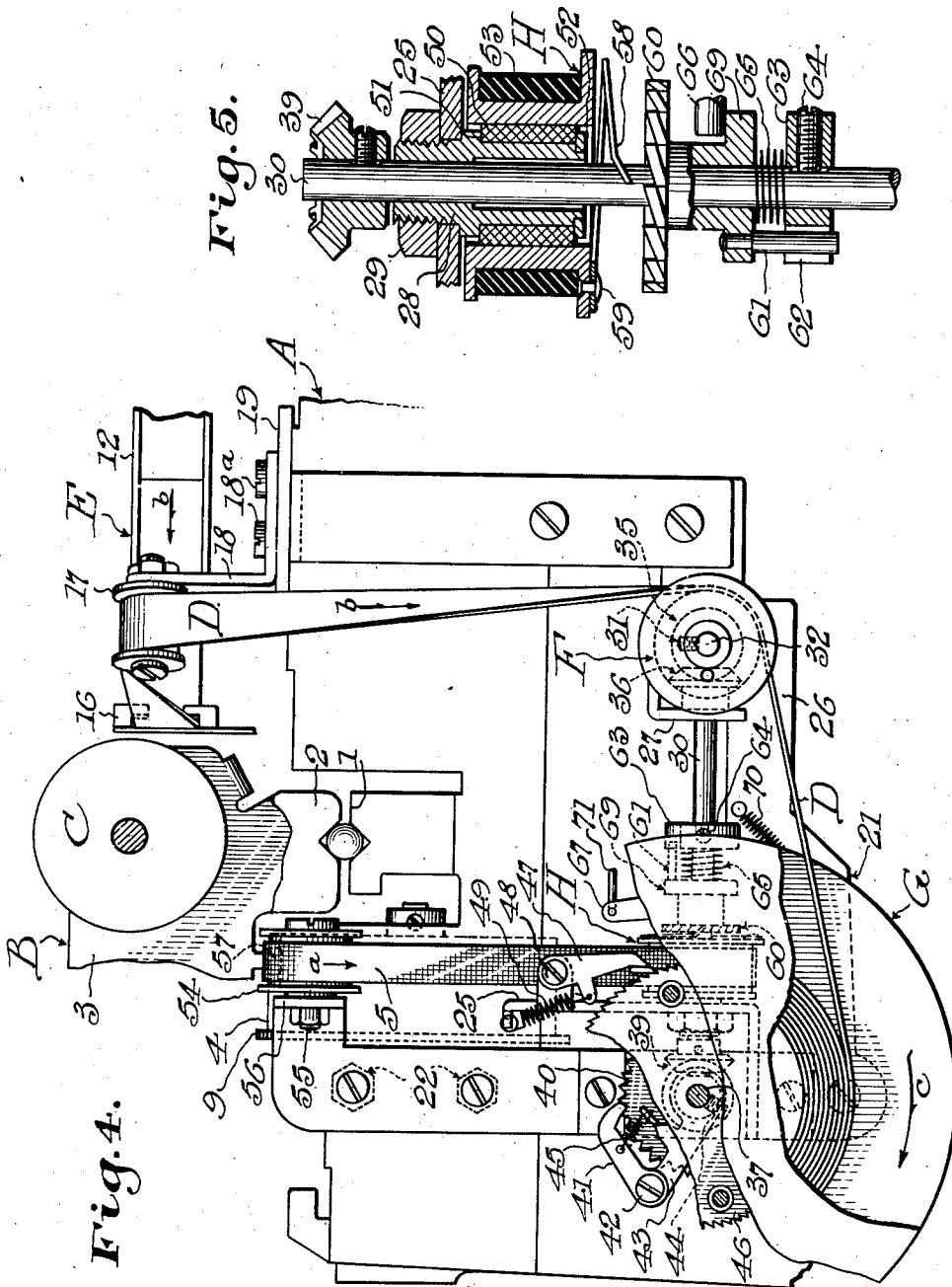

INVENTOR
George F. Handley
BY *Baldwin & Wiglet*
Attorneys

UNITED STATES PATENT OFFICE

2,280,702

TYPEWRITING MACHINE

George F. Handley, Glendale, N. Y., assignor to
Royal Typewriter Company, Inc., New York,
N. Y., a corporation of New York

Application January 18, 1941, Serial No. 375,061

2 Claims. (Cl. 197—153)

This invention relates to typewriting machines, and more particularly to typewriter ribbon positioning and feeding mechanism. Mechanism embodying the invention may be employed advantageously for positioning and feeding typewriter ribbons or strips of various kinds, but is especially adapted for positioning and feeding narrow carbon paper or like copying strips of carbon.

In the feeding of certain kinds of strips or ribbons, such as carbon ribbons for photo offset copy, typing on multilith plates or hektograph ribbons for making imprints which are subsequently used for producing positive copies, it is important to feed the ribbon at a rate corresponding to the rate of carriage letter-spacing travel so as to assure the presentation of a fresh ribbon portion at the printing point for each new type impression. The construction disclosed herein as illustrating one embodiment of the invention is capable of feeding ribbon in this way, but it will be apparent that the invention is not limited in its application to mechanism for feeding any specific type of ribbon.

An object of the invention is to provide typewriter ribbon mechanism of a simple and efficient construction operable in an improved manner in timed relation to the typewriter carriage letter-spacing travel. Generally stated, this object is accomplished by the interposition of simple driving connections between the ribbon-feeding mechanism and a carriage draw band connected in the usual manner between the carriage and a driving motor, such as the conventional spring barrel.

Another object is to provide mechanism of the character referred to above which may be easily applied as an attachment to a standard typewriter in a manner facilitating the making of driving connections between the carriage and the ribbon-feeding mechanism.

Other objects will become apparent from a reading of the following detailed description, the appended claims, and the accompanying drawings, in which:

Figure 1 is a fragmentary top plan view of a typewriting machine with some conventional parts omitted, and showing equipment embodying the invention applied thereto;

Figure 2 is a longitudinal vertical sectional view taken on the irregular lines 2—2 of Figure 1;

Figure 3 is a detailed transverse sectional view taken on the line 3—3 of Figure 1 and drawn on an enlarged scale;

Figure 4 is a partial end elevation looking in

the direction of the arrow IV in Figure 1, with some parts broken away, and drawn on an enlarged scale; and

Figure 5 is a detailed sectional view of a one-way drive ratchet or clutch drawn on an enlarged scale.

Mechanism embodying the invention may be used in connection with typewriters of various kinds. For the purposes of illustration, a preferred embodiment of the invention is shown applied to a Royal standard typewriter including a main frame A and a carriage B mounted on the frame for letter-spacing and return movements by means of a ball race frame rail 1 and a carriage rail 2. A platen C is mounted on the carriage end plates 3—3, and is adapted to be rotated for line-spacing by a combined line-spacing and carriage return lever (not shown). A spring-powered drum or barrel 4 journaled on the frame between the right and left end walls thereof is connected to the carriage by a draw band 5 for moving the carriage in the letter-spacing direction, that is, to the left as viewed in Figures 1 and 2. Such carriage movement is controlled by escapement mechanism of a known or any suitable kind and which may include an escapement wheel 6 journaled on an escapement frame (not shown) to rotate with a pinion 7 in mesh with an escapement rack 8 supported on the carriage B.

The spring barrel 4 is provided with a gear 9 which meshes with and drives a pinion 10 for rotating a shaft 11 connected to mechanism for driving the usual ink ribbon spools (not shown).

The parts referred to above may be of known construction and arrangement relative to each other, and, considered alone or in combination with each other, they do not constitute the invention claimed herein. The invention resides in other parts to be described, and the combinations of such other parts with each other and with parts which previously have been described.

Equipment for supplying and feeding ribbon D includes a ribbon supply means generally designated E mounted at the right-hand end of the typewriter, and from which the ribbon D is adapted to extend past the printing point to engage and be fed by a feed roll F mounted at the left-hand end of the machine, from whence the ribbon extends to a take-up spool G, the feel roll F and take-up spool G being driven by a driving pulley H interposed between the carriage draw band 5 and the feed roll and take-up spool, respectively. In operation, the driving pulley H is effective for driving the feed roll F and take-

up spool G only during letter-spacing movements of the carriage B to the left. When so driven, the feed roll F, which has peripheral contact with the ribbon D, draws the ribbon from the supply means E, thereby feeding it past the printing point. Ribbon discharged by the feed roll F is wound up on the take-up spool G. The drive ratio is such that the peripheral movement of the feed roll F is always the same as the letter-spacing movement of the carriage, and, consequently, the amount of ribbon D fed past the printing point will correspond to or with the carriage travel so as to assure the positioning of a fresh ribbon portion for each typing impression. The driving mechanism tends to rotate the take-up spool G at such angular velocity as would cause its effective peripheral velocity to be greater than the peripheral velocity of the feed roll F. In this way the ribbon D extending between the feed roll F and the take-up roll is maintained taut so as to promote snug winding of the ribbon on the take-up spool.

Referring more particularly to the details of construction of the illustrative embodiment of the invention, the ribbon supply means E includes a supply spool 12 journaled on a bracket 13 secured as at 14 to the main frame A. The ribbon D extends from the supply roll 12 around a flanged guide roller 15, and thence through the usual ribbon vibrator 16 and over a guide roller 17 journaled on a bracket 18 secured as at 18^a to a plate 19 fixed by screws 20 to the main frame A at the left-hand end of the typewriter.

The feeding and ribbon take-up mechanism is mounted on a sheet metal mechanism frame generally designated 21 mounted at the left-hand end of the frame A by means of posts 22. The frame is provided with a U-shaped bracket portion 23 secured to the frame 21 as at 24—24, and having a vertical ear portion 25. A forwardly projecting extension 26 integral with the frame 21 is provided with a vertically extending ear 27. A sleeve 28 secured to the ear 25 by means of a nut 29 cooperates with the ear 27 for journaling a shaft 30 which is parallel to the fore-and-aft extending, horizontal axis of the spring barrel 4. The shaft 30 is driven by means to be described later for driving both the feed roll F and the take-up spool G.

The feed roll F is secured by a set screw 31 to a shaft 32 extending transversely to the shaft 30 and journaled in vertical frame ears 33 and 34 at the end of the frame extension 26. A bevel gear 35 secured to the shaft 32 meshes with a bevel gear 36 secured to the shaft 30 and of the same pitch diameter as the gear 35. Thus, the shaft 32 will be driven at the same angular velocity as the shaft 30, and, since the diameter of the feed roll F is the same as the diameter of the pulley H, the peripheral velocities of the feed roll and pulley will be equal.

The ribbon take-up equipment is similar to that disclosed in the copending application of George F. Handley, Serial No. 359,119, filed September 30, 1940. It includes the take-up spool G mounted to turn freely on a shaft 37 which is journaled on the frame plate 21 and bracket portion 23. A bevel gear 38 fixed to the shaft 37 meshes with a bevel gear 39 fixed to the shaft 30. Impositive drive connections interposed between the shaft 37 and the take-up spool G include a serrated or saw-toothed wheel 40 fast with the take-up spool G and adapted to be driven by a slip drive pawl 41 pivoted as at 42 on an arm 43 secured by a set screw 44 to the shaft 37.

A spring 45 urges the pawl 41 into engagement with the toothed wheel 40 with such radial pressure that, when the shaft 37 and arm 43 are rotated, the take-up spool G will be driven impositively, the effective torque transmitted to the spool G being sufficient to maintain the ribbon D taut. However, the spring 45 will yield so as to permit slippage of the pawl 41 on the wheel 40 and allow the spool G to lag behind the shaft 37 so as not to exert too strong a pull on the ribbon D. In order to prevent the spool G from moving reversely, it is provided with a fine-toothed ratchet wheel 46 which is engaged by a back check pawl 47 pivoted as at 48 on the vertical frame ear 25 of the frame 21, the back check pawl being urged into engagement with the ratchet wheel 46 by a spring 49.

In accordance with the invention, the shaft 30, and, consequently, the feed roll F and take-up spool G are driven from the carriage draw band 5 during letter-spacing travel only. The driving pulley H which engages the draw band 5 for effecting the drive is equipped with a bearing bushing 50 journaled on the sleeve 28. The pulley is held against axial displacement on the sleeve by engagement of one end of the bushing 50 with a shoulder 51 formed on the sleeve, and by engagement of the other end of the bushing with a retaining washer 52 staked or otherwise suitably secured to the sleeve. For promoting smooth and dependable driving of the pulley H, it is provided with a rubber covering 53 which is contacted by the draw band 5.

The ribbon-feeding and take-up equipment is mounted outwardly beyond the left-hand end of the frame A, being thus easily attachable as a unit without revising the arrangement of the standard typewriter parts. For effecting operative driving connection between the draw band 5 and the ribbon-feeding and take-up mechanism without substantially changing the arrangement of the standard typewriter parts, an intervening portion of the draw band 5 is arranged to extend generally to the left to the driving pulley H, thence vertically upwardly to a flanged guide roller 54 journaled as at 55 on a frame ear 56, and thence another intervening portion extends to the right directly over but out of contact with the spring barrel 4 for connection to the carriage B as at 57.

When the carriage moves in the letter-spacing direction, the draw band 5 will travel in the direction of the arrow *a*, and the spring barrel 4 and the pulley H will be rotated counterclockwise as viewed in Figure 2. Conversely, when the carriage moves in the return direction, or to the right, the spring barrel 4 and pulley H will rotate clockwise as viewed in Figure 2. Inasmuch as it is desired to feed the ribbon D in the direction of the arrow *b* and rotate the take-up spool in the direction of the arrow *c* only during carriage letter spacing movements and counterclockwise rotation of the barrel 4 and pulley H, a one-way drive connection is interposed between the pulley H and the shaft 30. The one-way drive connection shown herein is similar to that disclosed in the copending application Serial No. 359,119 referred to above. It includes a spring pawl 58 riveted as at 59 to the pulley H, and normally being engageable with a toothed ratchet wheel 60 which is free on the shaft 30 but is adapted to be held in driving connection therewith by a pin 61 fixed to the wheel 60 and extending into a slot 62 in a collar 63 secured by a set screw 64 to the shaft 30. A spring 65 in-

terposed between the collar 63 and the ratchet wheel 60 normally holds the ratchet wheel close to the pulley H for cooperation with the spring pawl 53, so that, when the pulley H rotates counterclockwise as viewed in Figure 2, the shaft 30 will be rotated so as to drive the feed roll F and take-up spool G. When the driving pulley H is rotated clockwise during return travel of the carriage, the pawl 58 will slip over the teeth of the ratchet wheel 60 so as not to drive the shaft 30, the feed roll F, and take-up spool G.

When the carriage is moved in the letter-spacing direction during tabulating operations, it is unnecessary and is wasteful to feed ribbon correspondingly, and it therefore is desirable to disable the ratchet or clutch device 58—60 during tabulating operations. For accomplishing this, a pin 66 mounted on a lever 67 pivoted as at 68 on the frame plate 21 is movable against a flange 69 on the ratchet wheel 60 for pulling the ratchet wheel away from the spring finger 58. A spring 70, however, normally maintains the lever 67 and pin 66 in positions permitting the spring 65 to hold the ratchet wheel 60 in position for engagement by the spring finger 58. The lever 67 may be operated in unison with the tabulating mechanism by means of a pull link 71 adapted to be connected to the tabulating mechanism by means such as are disclosed in the copending application 359,119 previously referred to.

The mechanism disclosed herein embodies the invention in the form now preferred, but it will be apparent that changes may be made without departing from the invention as defined in the claims.

I claim:

1. A ribbon feeding attachment for a typewriter including a main frame having end walls, a carriage mounted on said frame for letter spacing and return travel, a motor driven barrel journaled on said frame intermediate said end walls to rotate about an axis transverse to the direction of carriage travel, and a carriage draw band secured respectively to said barrel and said carriage; said attachment comprising a mechanism frame adapted to be mounted on said main frame outwardly beyond that end wall of said frame towards which said carriage moves during

carriage letter-spacing travel, ribbon feeding mechanism mounted on said mechanism frame and including a drive pulley, and means so journaling said pulley on said mechanism frame that when the attachment is applied to the typewriter the pulley will be rotatable about an axis parallel to said barrel axis and outwardly beyond that end wall of said main frame towards which the carriage moves during letter-spacing travel, said pulley being adapted to be engaged by the carriage draw band with the latter having a portion extending from said barrel generally in the direction of carriage letter-spacing movement to and in driving contact with said pulley and another portion extending from said pulley and in the direction of carriage return movement to the point of attachment of the band to the carriage.

2. A ribbon feeding attachment for a typewriter including a main frame having end walls, a carriage mounted on said frame to move to the left for letter spacing and to the right for return travel, a spring barrel journaled on said frame to rotate about a horizontal axis extending fore-and-aft of the typewriter and disposed between the right and left end walls of the main frame, and a carriage draw band secured respectively to said barrel and said carriage; said attachment comprising a mechanism frame adapted to be mounted on said main frame outwardly beyond the left end wall thereof, ribbon feeding mechanism mounted on said mechanism frame and including a drive pulley, a guide roller and means so journaling said pulley and roller on said mechanism frame that when said attachment is applied to the typewriter the pulley and roller will be rotatable respectively about spaced axes parallel to said barrel axis outwardly beyond the left end wall of said main frame, the pulley and roller being so positioned as to be engaged by the draw band with the latter extending from said spring barrel to the left to and in peripheral contact with the pulley, thence extending upwardly and in peripheral contact with said roller, and thence extending to the right above and out of contact with said spring barrel and to the point of attachment to said carriage.

GEORGE F. HANDLEY.