



US00D435495S

United States Patent [19]

[11] Patent Number: **Des. 435,495**

McCoy et al.

[45] Date of Patent: **** Dec. 26, 2000**

[54] **HITCH MOUNT CARGO CARRIER AND HITCH COVER**

[75] Inventors: **Richard W. McCoy**, Granger;
Katherine A. Adams, Mishawaka;
Thomas W. Lindenman, South Bend,
all of Ind.

[73] Assignee: **Reese Products, Inc.**, Elkhart, Ind.

[**] Term: **14 Years**

[21] Appl. No.: **29/113,176**

[22] Filed: **Oct. 29, 1999**

Related U.S. Application Data

[63] Continuation-in-part of application No. 29/110,732, Sep. 10, 1999.

[51] **LOC (7) Cl.** **12-16**

[52] **U.S. Cl.** **D12/162**

[58] **Field of Search** D12/162, 172,
D12/203, 400, 406, 408-414.1; D3/23,
38; 224/504-505, 518-519, 521-526, 528-530,
42.43-42.44, 42.07-42.08; 280/163, 166,
30, 639, 769, 491.2, 415.1, 47.34; 296/37.1,
37.2; 108/129-132, 152, 44

[56] References Cited

U.S. PATENT DOCUMENTS

- D. 305,632 1/1990 Kraklio D12/400
- D. 356,200 3/1995 Kern et al. D34/38 X
- D. 370,452 6/1996 Beasley D12/203

- D. 398,434 9/1998 Agtuca D34/38 X
- 3,913,811 10/1975 Spencer 224/42.08
- 4,057,125 11/1977 Kroft 280/166 X
- 4,089,276 5/1978 Enos 108/44
- 4,234,284 11/1980 Hauff 224/42.44 X
- 4,274,648 6/1981 Robins 280/166
- 4,394,947 7/1983 Tartaglia 224/42.43
- 4,744,590 5/1988 Chesney 280/769
- 4,813,584 3/1989 Wiley 224/42.44
- 4,906,015 3/1990 Lacroix et al. 280/415.1
- 5,215,234 6/1993 Pastaglia 224/42.43
- 5,368,209 11/1994 Hill 224/42.44
- 5,570,826 11/1996 Garbes et al. 224/524
- 5,676,292 10/1997 Miller 224/524
- 5,853,278 12/1998 Frantz 224/504 X

Primary Examiner—Stacia Cadmus
Attorney, Agent, or Firm—Leon E. Redman; Lloyd D. Doigan

[57] CLAIM

The ornamental design for hitch mount cargo carrier and hitch cover, as shown and described.

DESCRIPTION

FIG. 1 is a perspective view of the hitch mount cargo carrier and hitch cover showing our new design;
FIG. 2 is an enlarged top plan view thereof;
FIG. 3 is an enlarged rear elevational view thereof;
FIG. 4 is an enlarged bottom plan view thereof;
FIG. 5 is an enlarged left side elevational view thereof, the right side being a mirror image of the left shown; and,
FIG. 6 is an enlarged front elevational view thereof.

1 Claim, 2 Drawing Sheets

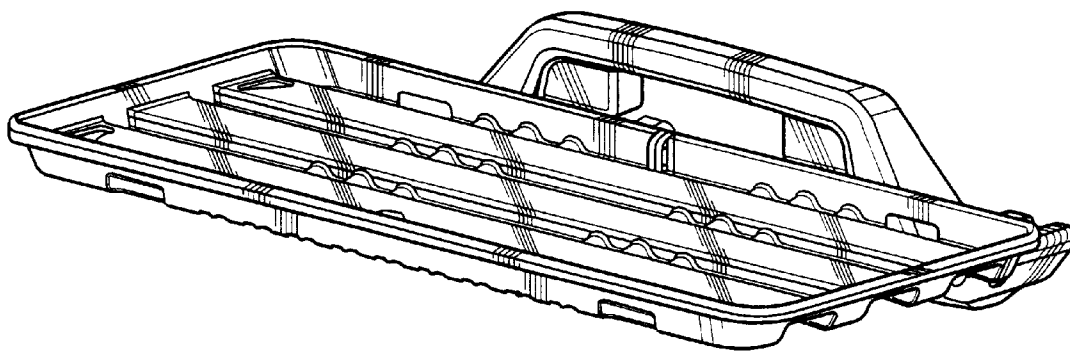

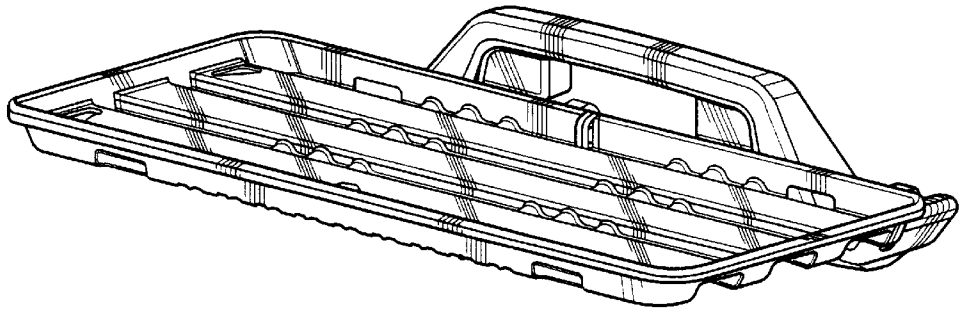

Fig-1

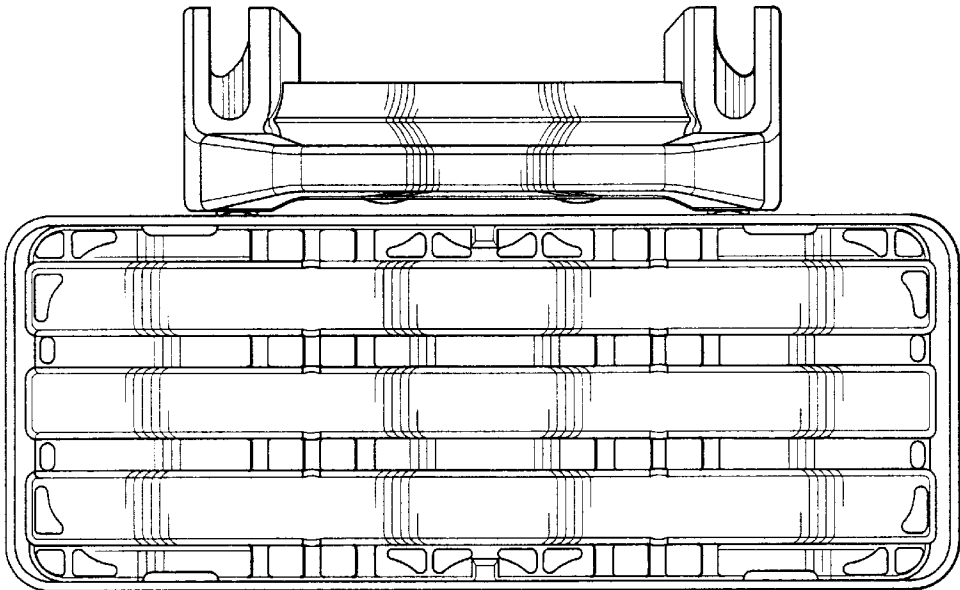

Fig-2

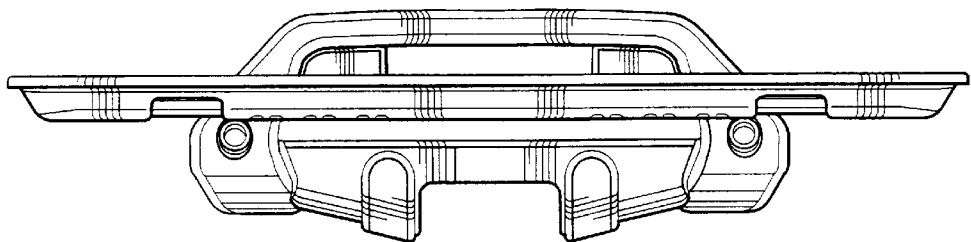

Fig-3

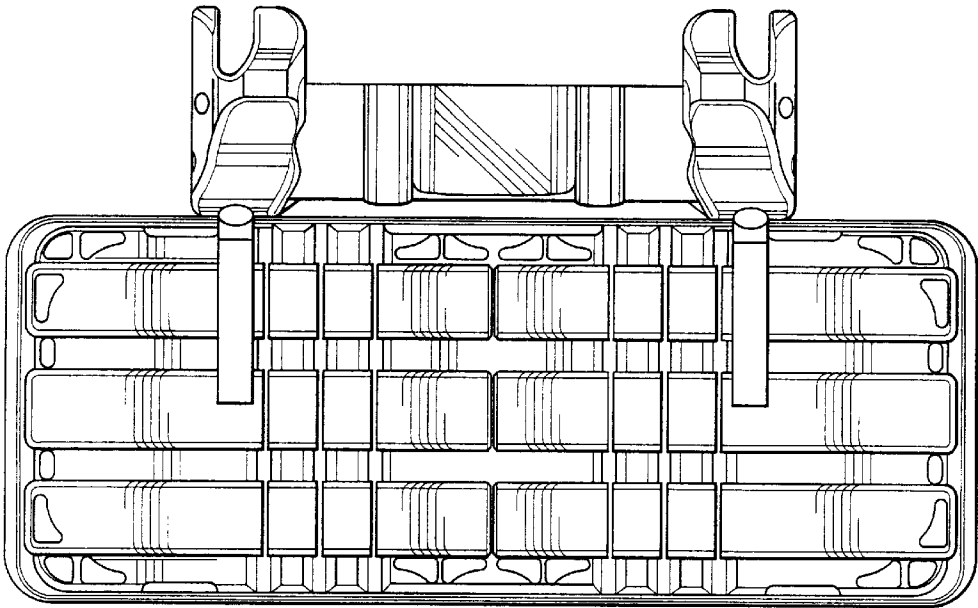

Fig-4

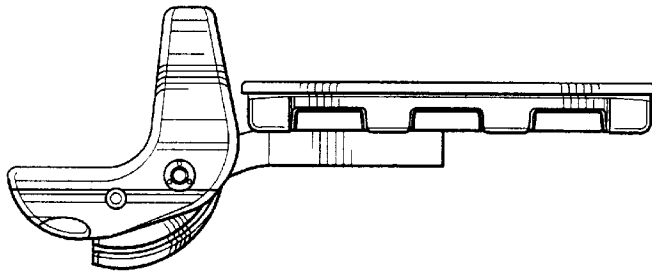

Fig-5

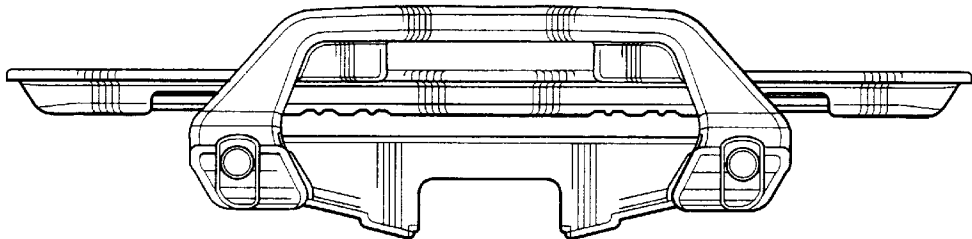

Fig-6