

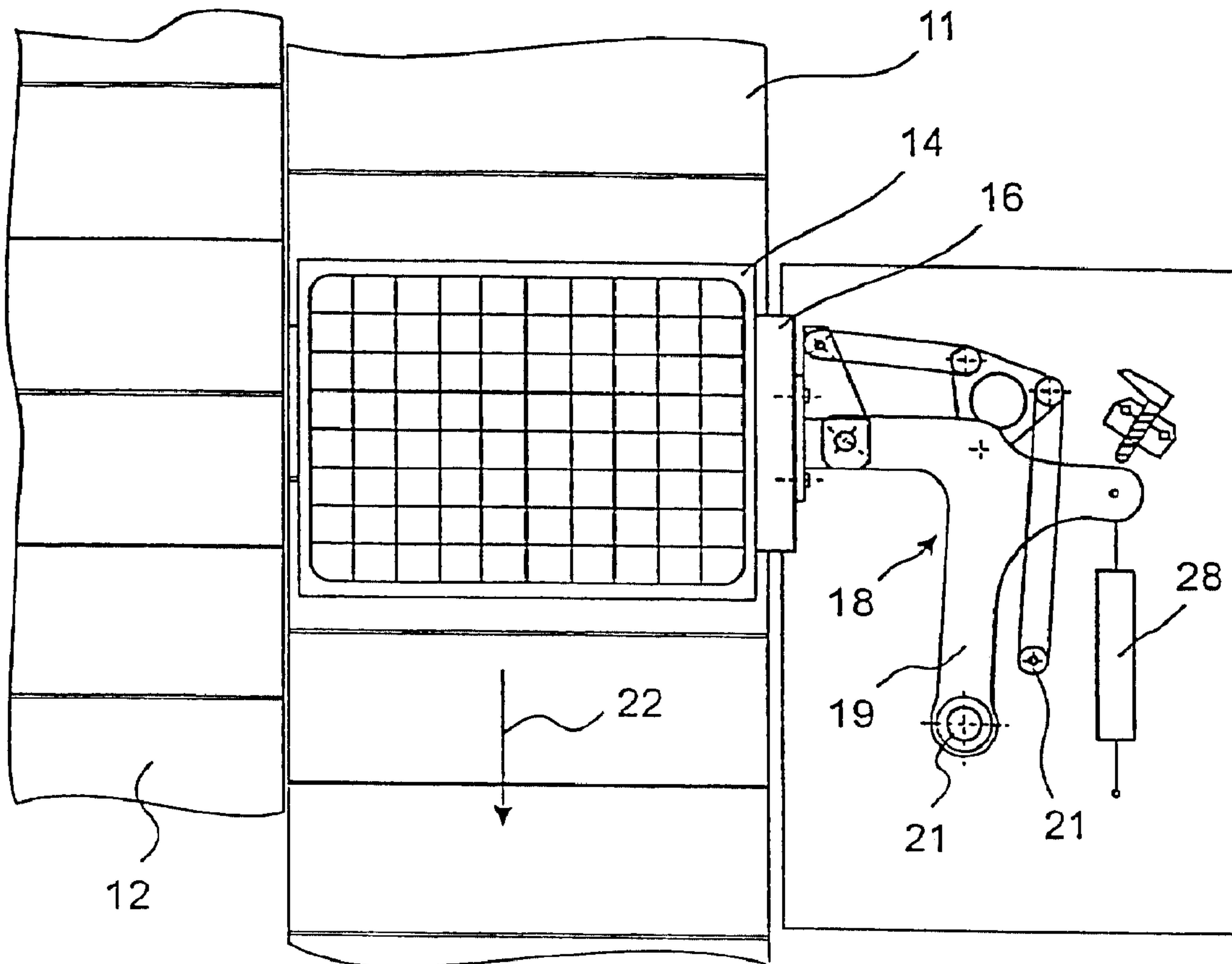

(86) Date de dépôt PCT/PCT Filing Date: 2002/09/06  
 (87) Date publication PCT/PCT Publication Date: 2003/03/27  
 (45) Date de délivrance/Issue Date: 2010/11/30  
 (85) Entrée phase nationale/National Entry: 2004/03/04  
 (86) N° demande PCT/PCT Application No.: EP 2002/009982  
 (87) N° publication PCT/PCT Publication No.: 2003/024848  
 (30) Priorité/Priority: 2001/09/19 (DE201 15 478.1)

(51) Cl.Int./Int.Cl. *B65G 47/82* (2006.01)  
 (72) Inventeurs/Inventors:  
 HEUFT, BERNHARD, DE;  
 KRISTANDT, GERD, DE  
 (73) Propriétaire/Owner:  
 HEUFT SYSTEMTECHNIK GMBH, DE  
 (74) Agent: FETHERSTONHAUGH & CO.

(54) Titre : DISPOSITIF DE REDIRECTION D'OBJETS PRESENTANT DES MASSES DIFFERENTES  
 (54) Title: DEVICE FOR REDIRECTING OBJECTS HAVING DIFFERENT MASSES



(57) Abrégé/Abstract:

In order to selectively divert objects (14), such as containers, packing, packing units, of different mass by means of a diversion device (10) from a first transport device (11) onto a second transport device (12), the progress of the diversion of an object (14) is



(57) **Abrégé(suite)/Abstract(continued):**

established by means of a device (30, 32), a control device (32) being activated depending on the established progress of the diversion such that, in the case of a lesser progress, a more intense or longer activation occurs and vice versa. The progress of the diversion can take place by means of an angle transmitter, linear encoder, a speedometer or an accelerator indicator, which measure the time required for a certain section or to reach a certain speed or acceleration, or, by means of a force sensor which measures the force required to move the object (14).

Abstract

In order to selectively divert objects (14), such as containers, packing, packing units, of different mass by means of a diversion device (10) from a first transport device (11) onto a second transport device (12), the progress of the diversion of an object (14) is established by means of a device (30, 32), a control device (32) being activated depending on the established progress of the diversion such that, in the case of a lesser progress, a more intense or longer activation occurs and vice versa. The progress of the diversion can take place by means of an angle transmitter, linear encoder, a speedometer or an accelerator indicator, which measure the time required for a certain section or to reach a certain speed or acceleration, or, by means of a force sensor which measures the force required to move the object (14).

-----  
DEVICE FOR REDIRECTING OBJECTS HAVING DIFFERENT MASSES  
-----

Description

The invention relates to an apparatus for selective diversion of objects such as containers, packing, packing  
5 units of different mass. The apparatus has a first transport device for the objects and a diversion device for diverting predetermined objects from the first transport device onto a second transport device. The intensity with which the objects are diverted from the first transport  
10 device onto the second transport device is controlled by means of a control device.

Such diversion apparatuses are used to divert faulty objects, e.g. containers which are not completely full,  
15 from a flow of such objects.

From WO 00/68120 (= DE-U-299 08 036) it is known to control the intensity with which objects are diverted in such a way that the objects receive a diversion impulse of differing  
20 strength transversely to their direction of transport and thus reach one of several second transport devices running parallel alongside each other.

A similar apparatus is known from DE-A-100 07 627 in which  
25 upright bottles are diverted by means of a single impulse of a pusher, while horizontal bottles are diverted by means of an impulse sequence of the pusher.

An apparatus for sorting out faulty packaging units is  
30 known from DE-C2-36 23 327, the angle at which the pusher pushes the packaging units from the conveyor belt being automatically controlled. The angle is set depending on the transport speed of the conveyor belt and the vector

perpendicular to it of the required pushing speed.

An apparatus for sorting out faulty packaging units, in particular bottles, is known from DE-C1-37 34 599, the  
5 pusher being driven by a cam and developed as a slide plate to which a brushing segment is attached. The acceleration and the speed of the slide during the sorting-out process are determined by the shape and the speed of rotation of the cam. It is to be thereby  
10 achieved that the path by which the packaging units to be sorted out are pushed is independent of the degree of filling of the packaging units.

Diversion devices have a diversion element, displaceable  
15 transversely to the direction of transport, which is driven pneumatically or by electric motor. The diversion element can also be in an air jet which pushes an object to be diverted transversely to the direction of transport. In the case of diversion apparatuses in which  
20 objects of different mass are to be diverted onto a second transport device, there is the difficulty that light objects are more markedly accelerated by the diversion device and thereby obtain a higher speed component transversely to the direction of transport than  
25 heavier objects.

The present invention creates a diversion apparatus which imparts a transverse impulse to objects regardless of their mass and which leads to a roughly equally wide  
30 displacement of the objects transversely to the direction of transport.

Accordingly, the present invention provides an apparatus for the selective diversion of objects of different mass,

2a

comprising: a first transport device for the objects; a second transport device for the objects adjacent to the first transport device; a diversion element for diversion of predetermined objects from said first transport device  
5 onto said second transport device in a diversion movement a device for establishing the progress of the diversion of an object; and a control device for controlling the intensity with which the diversion element diverts the objects from the first transport device onto the second  
10 transport device, the control device being activated depending on the established progress of the diversion such that, in the case of a lesser progress, one of a stronger activation and a longer activation occurs for the remainder of the diversion movement, and in the case  
15 of a greater progress, one of a lesser activation and a shorter activation occurs for the remainder of the diversion movement.

Due to their greater mass heavy objects initially have a smaller speed component transversely to the direction of transport from the diversion element. The progress of the diversion is monitored by means of a sensor for example by measuring the period of time that the diversion element or the object to be diverted requires in order to reach a certain point of its diversion movement. When the sensor reports that this period of time is over a certain value the diversion device is activated more strongly for the remainder of the diversion movement, i.e. in the case of a pneumatic diversion device the diversion element is extended with a higher pressure or further and in the case of a diversion element driven by electric motor the voltage of the electromotor drive is increased or applied for a longer period. In the case of a diversion element in the form of an air jet, the nozzle pressure is increased or likewise applied for a longer period.

In another embodiment the speed reached by the diversion element at a certain point in time after the start of the diversion process is measured. An angle transmitter, a linear encoder, a speedometer or an acceleration indicator can be used for this. The basic idea is in each case that a heavier object requires more time for the predetermined section or has reached a lesser speed than a lighter object, so that the diversion device has to be activated correspondingly more strongly or for longer.

The diversion device can also be controlled by integrating in the diversion element a force sensor which measures the force with which the diversion element presses against the object. An object of greater mass will offer greater resistance to the diversion element, so that a higher force is measured.

35

In the case of a diversion element driven by electric motor the power consumption can also be used as a criterion.

Depending on the established progress the diversion device is activated, the activation being greater or for longer for a lesser progress and vice versa. Thus if a relatively  
5 low speed or a long extension time is ascertained at a predetermined point, the diversion device is activated more strongly or for longer. In the case of a pneumatic drive of the diversion device e.g. the pressure supplied to the  
10 cylinder is increased or the diversion element is further extended, i.e. the object is accelerated for a longer period by the diversion element transversely to the direction of transport. Correspondingly in the case of a drive by electric motor the supplied power is increased or the diversion process is prolonged.

15

The diversion apparatus according to the invention can also be used to divert objects of different mass from a first transport device onto one of several second transport devices. The further away from the first transport device  
20 the concerned second transport device is, the more strongly must the diversion device be activated, the activation additionally taking place according to the invention corresponding to the mass of the object.

25 The diversion apparatus according to the invention is suitable in particular for transport units in which the objects are transported past the diversion element at a very small distance of at most a few millimetres. The distance is to be particularly small compared to the length  
30 of the diversion movement of the diversion element. If the distance is greater, e.g. 2 cm, the diversion apparatus according to the invention can also be used for stable objects, such as beer crates or mineral-water crates if the distance is at least always the same.

35

An embodiment of the invention is explained below with reference to the drawing. There are shown in:

Fig. 1 the diversion device from above in the resting position;

5 Figs. 2 and 3 the diversion device of Fig. 1 at different times during a diversion process; and

Fig. 4 the chronology of a diversion process.

10 A diversion device 10 is arranged next to a first conveyor 11 which is a link chain conveyor. The first conveyor 11 conveys an object 14, which is a beer crate in the represented example, past the diversion device 10. The diversion device 10 serves to push certain objects 14, e.g.  
15 not completely filled beer crates, from the first conveyor 11 onto a second conveyor 12 running parallel alongside it and thus exclude them from the further production process.

The diversion device 10 contains a diversion element 16,  
20 which can be swivelled by means of a swivel arm 18. The diversion element 16 is a plate aligned in the direction of transport, and the swivel arm 18 is designed so that the alignment of the diversion element 16 is maintained upon swivelling out. To this end the swivel arm 18 consists of a  
25 main lever 19 and a parallel lever 20.

The pivot points 21 of the main lever 19 and of the parallel lever 20 are arranged vis-à-vis the diversion element 16 at a distance in the direction of transport  
30 indicated by the arrow 22, so that, upon swivelling out, the diversion element 16 moves at the same time roughly in the direction of transport. The object 14 is thus pushed essentially transversely, upon swivelling out of the diversion element 16, on the first conveyor 11, without a  
35 greater relative movement in the direction of transport taking place between the object 14 and the diversion element 16.

The main lever 19 is roughly T-shaped and is coupled at the bottom end of the vertical T-column in the pivot points 21. In the starting position shown in Fig. 1 the vertical T-column lies roughly counter parallel to the direction of transport 22. The diversion element 16 is coupled at the end of the horizontal T-bar pointing towards the first conveyor 11, while a swivel cylinder engages at the end pointing away from the first conveyor 11. A sensor 30 is arranged at a small distance from this end of the horizontal T-bar. The sensor 30 produces a trigger signal when the end of the T-bar moves past it. This trigger signal is produced if the parallel lever 18 has swivelled by roughly  $2^\circ$  which corresponds to an extension section of the diversion element 16 of roughly 17 mm (Fig. 2). The period of time  $t$  which passes between the triggering of the swivel cylinder 28 and the occurrence of the trigger signal serves as a measure of the mass of the object 14. The longer this period of time  $t$ , the greater the mass of the object 14. The length of the trigger time  $T$  of the swivel cylinder 28 is controlled according to this period of time  $t$  by means of a control device 32. There are three gates lying one behind the other for the period of time  $t$ . If the period of time  $t$  falls within the range of the first gate  $G_1$ , trigger time  $T_1$  is chosen. If the period of time  $t$  falls within the range of the second gate  $G_2$ , trigger time  $T_2$  which is greater than  $T_1$ , is used. If the period of time  $t$  falls within the third gate  $G_3$ , then trigger time  $T_3$  which is greater than  $T_2$ , is chosen (Fig. 4).

30

The trigger times  $T$  are established experimentally and taught to the control device 32. In the represented embodiment the trigger time  $T$  is controlled stepwise. However, it is preferably controlled continuously via a characteristic line. For this, several points of the characteristic line are established experimentally and the

35

curve sections lying in between are interpolated.

When experimentally establishing the trigger times  $T$  or the characteristic line, the influence of the differing  
5 friction of heavier and lighter objects can be taken into account.

List of reference numbers

- 10 diversion device
- 11 first conveyor
- 12 second conveyor
- 14 object
- 16 diversion element
- 18 parallel lever
- 19 main lever
- 20 auxiliary lever
- 21 point of rotation
- 22 direction of transport
- 28 swivel cylinder
- 30 sensor
- 32 control device

The embodiments of the invention in which an exclusive property or privilege is claimed are defined as follows:

1. An apparatus for the selective diversion of objects of different mass, comprising:
  - a first transport device for the objects;
  - a second transport device for the objects adjacent to the first transport device;
  - a diversion element for diversion of predetermined objects from said first transport device onto said second transport device in a diversion movement;
  - a device for establishing the progress of the diversion of an object; and
  - a control device for controlling the intensity with which the diversion element diverts the objects from the first transport device onto the second transport device, the control device being activated depending on the established progress of the diversion such that, in the case of a lesser progress, one of a stronger activation and a longer activation occurs for the remainder of the diversion movement, and in the case of a greater progress, one of a lesser activation and a shorter activation occurs for the remainder of the diversion movement.
2. The apparatus according to claim 1, wherein the progress of the diversion is established by measuring the period of time  $t$  within which one of the diversion element and the object to be diverted has covered a predetermined path.
3. The apparatus according to claim 1, wherein the progress of the diversion is established by measuring at a certain time after the start of the diversion

process one of a speed and an acceleration reached by one of the diversion element and the object to be diverted.

4. The apparatus according to claim 3, wherein a means to measure one of the speed and the acceleration reached at a certain point after the start of the diversion process is selected from the group consisting of an angle transmitter, a linear encoder, a speedometer and an acceleration indicator.
5. The apparatus according to claim 1, wherein the progress of the diversion is established by force sensor means to measure the force required to move the object.
6. The apparatus according to any one of claims 1 to 5, wherein the diversion device is driven pneumatically.
7. The apparatus according to any one of claims 1 to 5, wherein the diversion device is driven by electric motor.
8. The apparatus according to claim 1, wherein the diversion device is driven by an electric motor and the progress of the diversion is established by measuring power consumption of the electric mixer.
9. The apparatus according to any one of claims 1 to 8, wherein one of the intensity and duration of the activation of the diversion device is controlled by reference to a continuous characteristic line depending on the period of time  $t$ .
10. The apparatus according to any one of claims 1 to 9, wherein the objects are transported at a distance of at most a few millimeters past the diversion device.

11. The apparatus according to any one of claims 1 to 10, wherein the objects are selected from the group consisting of containers, packaging and packing units.

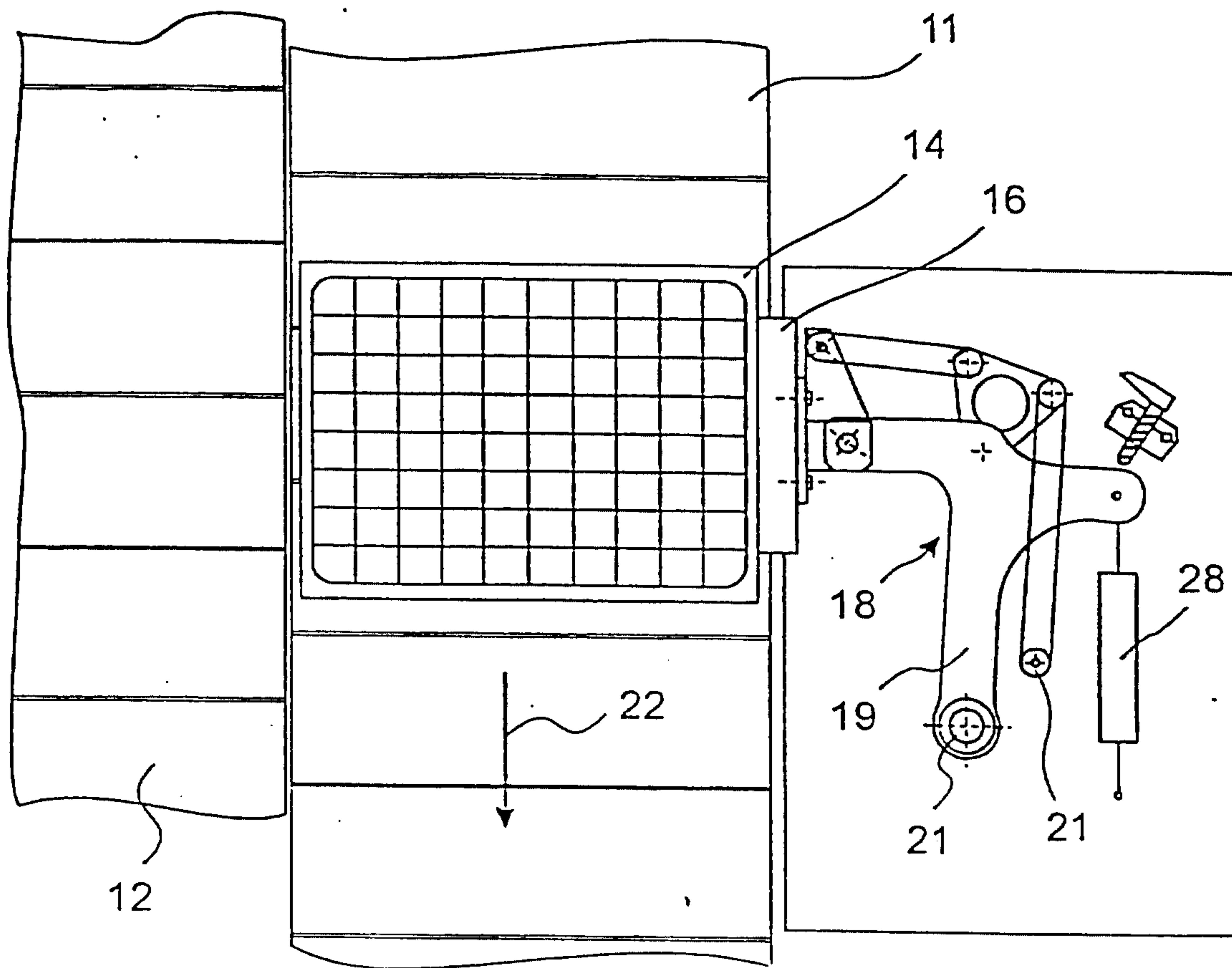

Fig. 1

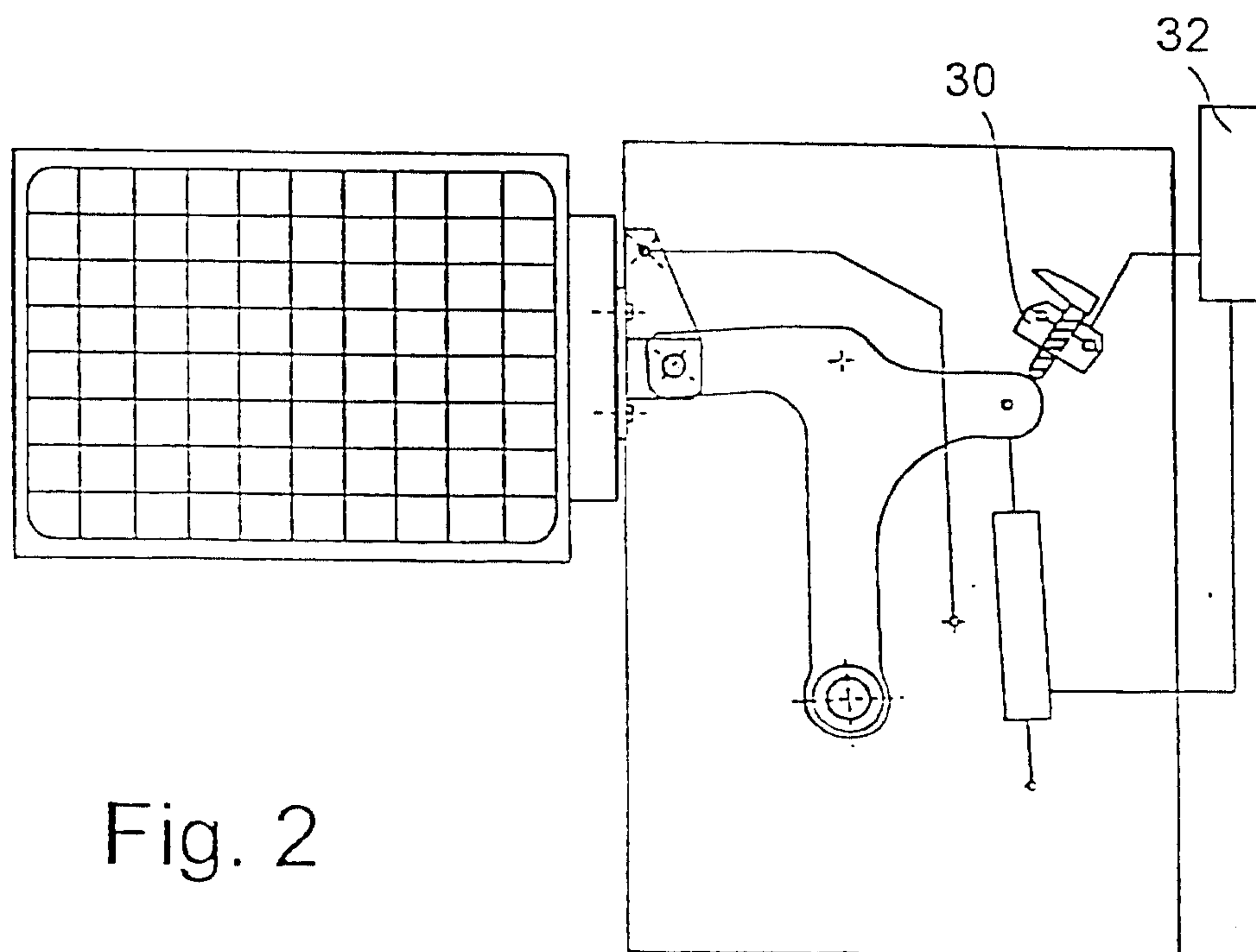

Fig. 2

2/2

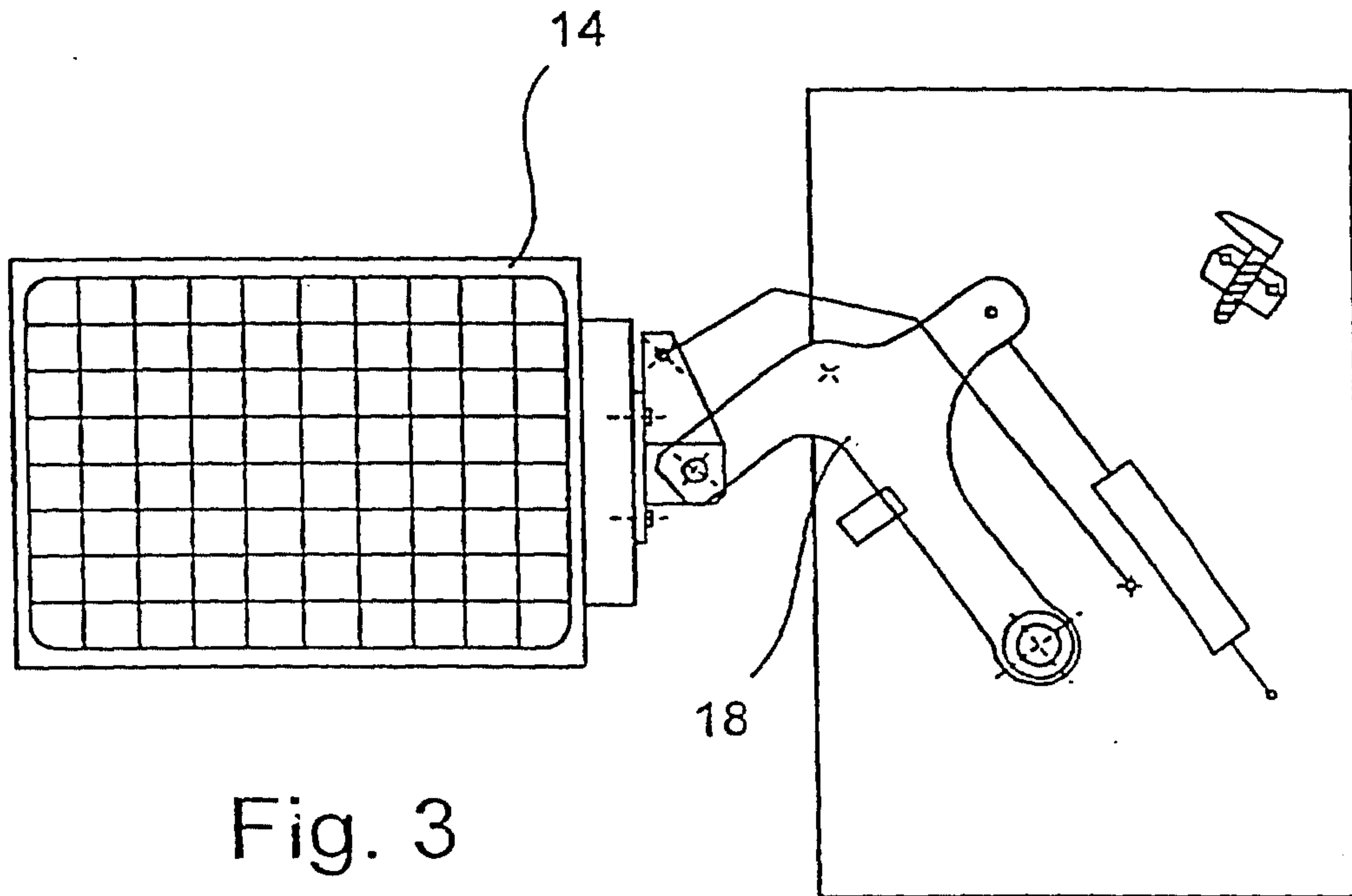

Fig. 3

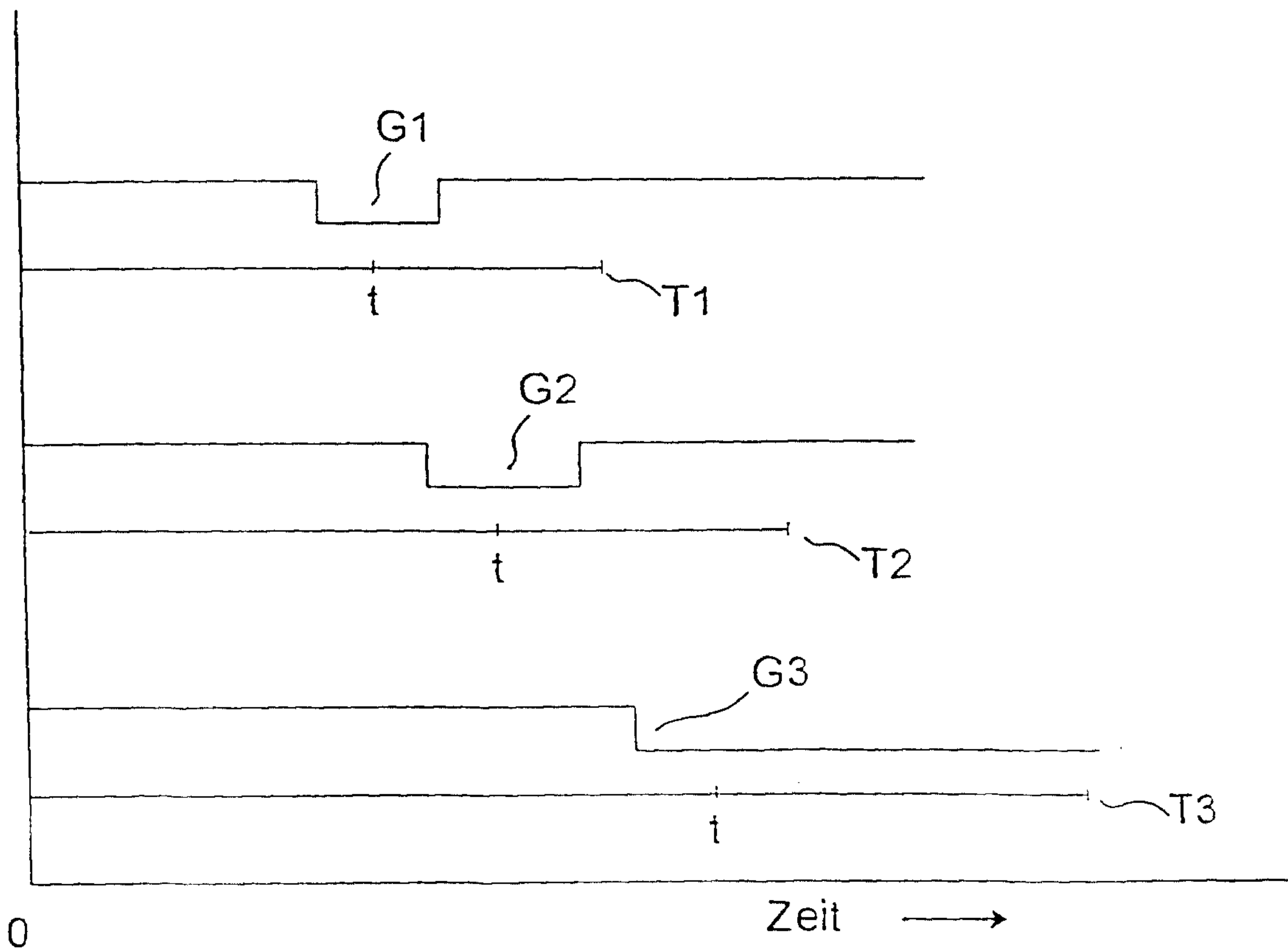

Fig. 4

