

(No Model.)

I. BROKAW.
SIPHON OIL CAN.

No. 525,975.

Patented Sept. 11, 1894.

Fig. I.

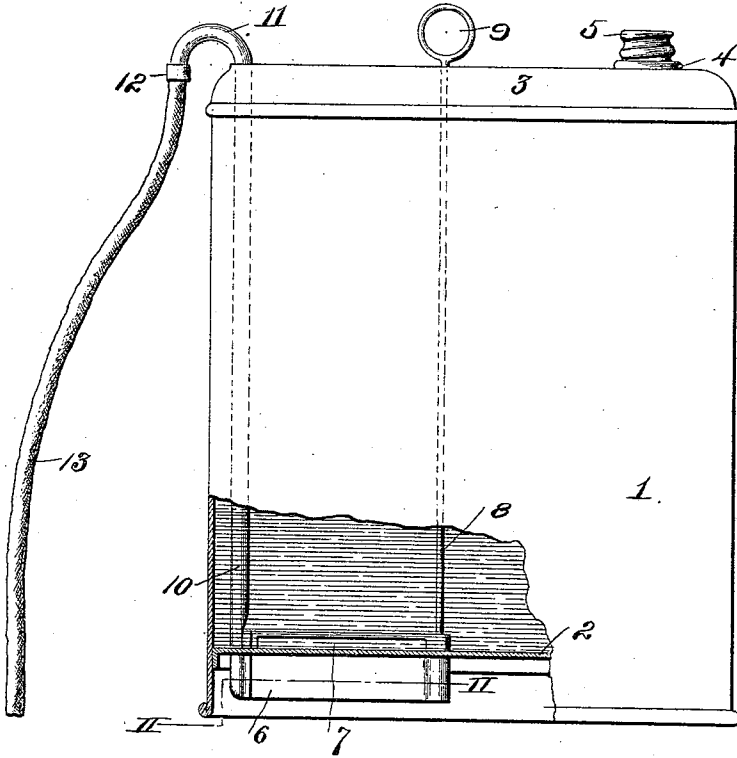

Fig. II.

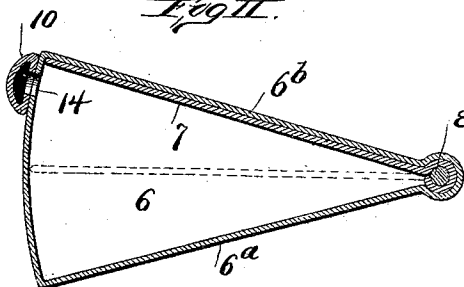
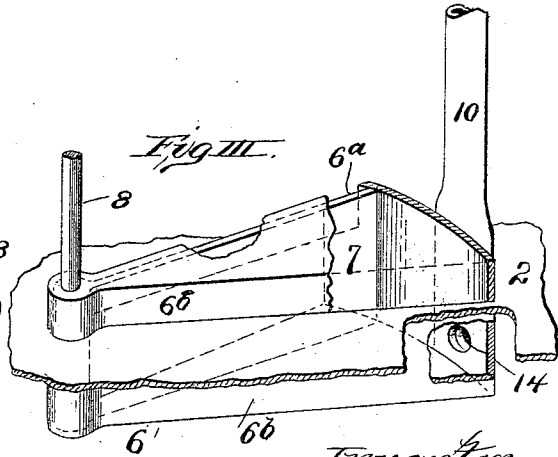

Fig. III.



Attest:
A. M. Ebersole
L. S. Ebersole

Inventor:
Isaac Brokaw
By Knight Bros.
Attest

UNITED STATES PATENT OFFICE.

ISAAC BROKAW, OF LITCHFIELD, ILLINOIS, ASSIGNOR OF ONE-HALF TO
PHILIP D. WELLS, OF SAME PLACE.

SIPHON OIL-CAN.

SPECIFICATION forming part of Letters Patent No. 525,975, dated September 11, 1894.

Application filed October 17, 1893. Serial No. 488,389. (No model.)

To all whom it may concern:

Be it known that I, ISAAC BROKAW, of Litchfield, in the county of Montgomery and State of Illinois, have invented a certain new and useful Improvement in Siphon Oil-Cans, of which the following is a full, clear, and exact description, reference being had to the accompanying drawings, forming part of this specification.

The subject of my invention is an oil can provided in its bottom with a segment-formed chamber which communicates with the ascending siphon pipe, and a circumferentially swinging plate or gate having horizontal motion in said chamber, imparted by a vertical rock-shaft, in order to force oil up into said siphon to fill the same and establish siphonic action therein.

In the accompanying drawings:—Figure I is a sectional elevation of an oil can illustrating my invention. Fig. II is a horizontal section, on a larger scale, on the line II—II, Fig. I. Fig. III is a perspective view of the circumferentially swinging plate, or gate segment chamber and siphon pipe seen from the opposite side.

The oil can 1 is constructed with an elevated bottom 2, and with a closed top 3, in which is the customary screw nozzle 4 for filling, closed by a cap 5. In the elevated bottom 2, is a chamber 6 of segment shape, closed at top and adapted to receive a circumferentially swinging plate or gate 7, which is reciprocated in a horizontal plane by means of a vertical rock-shaft 8, provided at top with a handle 9, for this purpose. To an aperture 14, near one corner of the outer curved end of the segment chamber 6, is secured the ascending leg 10 of the siphon pipe, which is formed at top with a goose-neck 11, extending above the top of the can, and beyond the periphery thereof, and provided with a coupling 12, by which a flexible or other tube 13, forming the descending leg of the siphon is attached to the said goose-neck. The wall 6^a on the receiving side of the chamber is made lower than the opposite wall 6^b, to permit the free ingress of oil, and the circumferentially swinging plate or gate 7 fits in the chamber with sufficient accuracy to cause it, when moved toward the delivery wall 6^b to eject

the oil through the delivery aperture 14 into the ascending leg 10 of the siphon, and also to withdraw the oil therefrom, when it is returned with a rapid or prompt movement toward the receiving wall 6^a. As this does not necessitate tight packing of the plate or gate 7 within the chamber or well 6, the chamber is always filled with oil when the plate or gate rests in the position shown in Fig. III.

Operation: The circumferentially swinging plate or gate 7 being at rest in its normal position, against the receiving wall 6^a of the chamber, as shown in Fig. III, and the chamber full of oil, if it be desired to fill a lamp or to decant the oil from the can to another vessel, the vessel is placed beneath the descending leg 13 of the siphon, and the plate or gate 7, by means of the handle 9 of the rock-shaft 8, is turned circumferentially with a prompt movement toward the delivery wall 6^b of the chamber, ejecting sufficient oil through the aperture 14, and up the siphon leg 10 to fill the siphon, and set up siphonic action therein, and leaving the aperture exposed, as shown in Fig. II. As the delivery tube 13 of the siphon descends to a level below that of the bottom of the oil can, the siphonic action, if not arrested will continue automatically until the can is emptied of oil. When the lamp or other vessel is filled, or a sufficient quantity of oil has been decanted, a reverse movement of the plate or gate 7, toward the receiving wall 6^a, causing a partial vacuum within the chamber, withdraws the oil from the siphon 10, 11, 13, so as to stop the flow, and if necessary, any superfluity of oil can be withdrawn from the lamp or other vessel by the same movement. By repeated backward movements of the plate, or gate alternating with slow forward movements, any desired quantity of oil may be pumped from a lamp or other vessel into the can 1.

I claim as my invention—

1. A siphon oil can, constructed substantially as herein described, with a segment chamber in its bottom, and a siphon-pipe in combination with a circumferentially swinging plate or gate movable in the chamber in a horizontal plane, and a vertical rock-shaft for actuating said plate, substantially as described.

2. The combination of the can 1, having elevated bottom 2, the segment chamber 6 forming a well in the bottom 2 the circumferentially swinging plate or gate 7, movable in a horizontal plane in the chamber and a suitable siphon pipe 10, 11, 13, communicating with said chamber, substantially as described.

3. The segment chamber 6, constructed with an open front 6^a, for the admission of oil, and a closed back 6^b, in combination with a circumferentially swinging plate or gate 7, a vertical rock-shaft to which the plate or gate 7 is attached, and a siphon pipe 10, 11, 13, communicating with the chamber and receiving oil therefrom by the horizontal movement of the plate, substantially as described.

4. The combination of an oil can, a segment chamber located in the bottom of the can, having an opening at one side, and an aperture in the curved wall, a siphon connected with the aperture, and a circumferentially swinging plate or gate located in the chamber seating beyond the aperture for starting the siphonic action, and returned to the opposite side for uncharging the siphon having a rock-shaft by which the plate or gate is swung in a horizontal plane; substantially as described.

ISAAC BROKAW.

In presence of—
WM. CARTER,
WM. HELMICK.