

(19)



(11)

EP 2 453 025 A1

(12)

EUROPEAN PATENT APPLICATION

(43) Date of publication:
16.05.2012 Bulletin 2012/20

(51) Int Cl.:
C14B 5/00 (2006.01) B21D 28/36 (2006.01)
B26F 1/04 (2006.01)

(21) Application number: **11187900.3**

(22) Date of filing: **04.11.2011**

(84) Designated Contracting States:
AL AT BE BG CH CY CZ DE DK EE ES FI FR GB GR HR HU IE IS IT LI LT LU LV MC MK MT NL NO PL PT RO RS SE SI SK SM TR
Designated Extension States:
BA ME

(71) Applicant: **Teseo S.p.A.**
63900 Fermo (IT)
(72) Inventor: **Gallucci, Gianni**
63015 MONTE URANO (ASCOLI PICENO) (IT)
(74) Representative: **Dall'Olio, Christian et al**
INVENTION S.r.l.
Via delle Armi, 1
40137 Bologna (IT)

(30) Priority: **10.11.2010 IT BO20100678**

(54) **A cutting device for cutting shapes in leathers**

(57) The cutting device (1) for cutting shapes in leathers is suitable for mounting in machines for cutting leathers. The device (1) comprises a body (2) exhibiting a end portion (21), and a drum-shaped element (3) exhibiting an external peripheral surface (32). The element (3) is provided, along the said external peripheral surface (32), with a series of housings, and is rotatably mountable on the end portion (21) of the body (2) such that the external peripheral surface (32) thereof can rotate about an axis (C) which is perpendicular to the end portion (21).

The device (1) has available a series of cutting tools (31), each of which is provided with a respective cutting edge, having different profiles from one another. Each of the cutting tools (31) is mountable in a corresponding housing of the series of such that the cutting edges thereof face in an external direction. The drum-shaped element (3) is rotatable about the axis (C) with respect to the end portion (21) of the body (2) such that a single cutting tool (31) at a time can be positionable facing the leather and the cutting edge thereof faces towards the leather in which a shape is to be cut.

FIG. 3

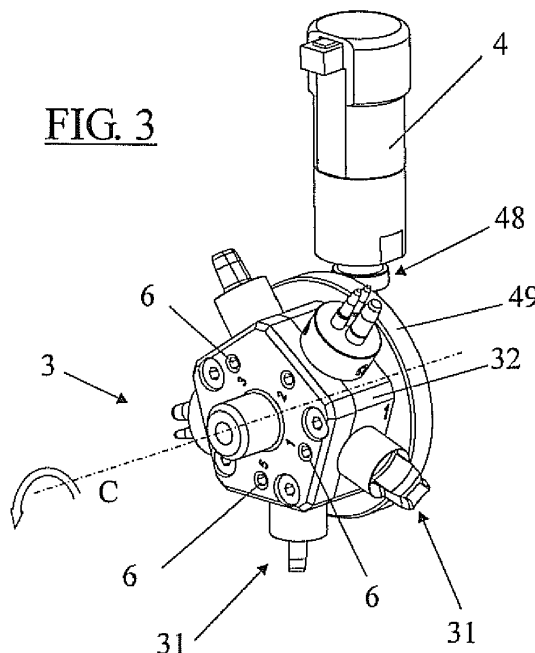

EP 2 453 025 A1

Description

[0001] The present invention relates to the technical sector of automatic machines used for realising, in leathers and/or hides, through-holes or cut-out parts exhibiting specially-shaped profiles as required.

[0002] These automatic machines exhibit a frame which is positioned above the leather and/or hide, which has been stretched on a work plane and on which the various profiles are cut as required, and which frame, by means of relative motor organs, is moved in translation above the leather.

[0003] The motors for controlling and moving the frame are programmable and commandable by a relative managing and control unit in which the various positions on the leather are memorised, where there is a need to realise various shapes following the relative perforation or cut.

[0004] In this regard, cutting or perforating devices are predisposed on the frame of the automatic machines; these devices exhibit a relative cutting or perforating tool having a cutting edge which exhibits an appropriate profile or shape to be created on the leather.

[0005] In the sector jargon, the cutting tool is commonly called the shapercutter.

[0006] The cutting edge of the shapercutter can be closed, in the case in which a cut shape is to be obtained which has a closed shape or profile, or the edge can be open in a case in which a cut shape having an open edge is to be obtained on the leather, i.e. a shape with a profile that is closed on itself.

[0007] The cutting device usually comprises a body for supporting the shapercutter; this body is mounted with respect to the frame in such a way that the cutting edge of the shapercutter is facing towards the leather and in such a way as to be movable in alternating translation perpendicularly to the leather on which the perforations or profiled cuts are to be realised.

[0008] In this way the cutting edge of the shapercutter (cutting tool) can be made to cross the underlying leather and cut, by means of pressure, a relative shaped portion corresponding to the profile of the edge of the cutting tool; the cut and shaped portion is circumscribed internally of the cutting edge.

[0009] The cutting devices at present used have a single cutting tool (or shapercutter) which is provided with a corresponding sole and single cutting edge having a relative profile to be transferred onto the leather following the cutting of the relative profiled portion.

[0010] At present, should, for various reasons or special requirements, there be the need to realise cuts in the leather in different positions, various perforations or profiles exhibiting different shapes or profiles, it is necessary, before any cutting operation, to proceed first with the removal of the cutting tool (shapercutter) from the cutting device and then to replace it with another tool having a cutting edge with a relative suitable profile for the desired shape to be cut in the leather.

[0011] It is clear that for all replacement operations, the machine must be stopped in order to allow the operator to perform the removal operation and the replacement of the tool.

[0012] An aim of the present invention is therefore to disclose a device for cutting shapes in leathers, usable in automatic machines that are used for obtaining relative variously-profiled shapes in leathers, which device obviates the above-cited drawbacks.

[0013] In particular, an aim of the present invention is to provide a device which enables performing the leather cutting operations which require realising various-profile shapes without having to halt the machine.

[0014] The aim of the present invention is obtained with a device for cutting shapes in leathers, in accordance with the contents of claim 1.

[0015] Other advantageous characteristics of the device of the present invention are set out in the various dependent claims.

[0016] The characteristics of the device for cutting shapes in leather, of the present invention, are set out in the following description, made with reference to the accompanying figures of the drawings, in which:

figure 1 is a perspective view, with some parts removed for greater clarity, of the main elements constituting the device of the present invention;

figure 2 is a partial exploded perspective view, with some parts removed, from a different perspective from the one of figure 1, of some particularly significant elements of the disclosed device;

figure 3 is a perspective view of a detail of the structure of figure 2;

figure 4 illustrates, in a lateral view, the device of the present invention in its entirety when mounted on a frame (M), partially illustrated, of an automatic machine for cutting leathers;

figure 5 is the device of the invention, shown in its entirety, in a lateral view that is different from the view of figure 4;

figure 6 is the view along section plane A-A of figure 5, while

figure 7 illustrates the view according to plane B-B of figure 5.

[0017] With reference to the figures, 1 denotes the device for cutting shapes in leathers of the present invention.

[0018] This device 1, for example as illustrated in figure 4, is suitable for being mounted on a frame (M) of an automatic machine for cutting leathers.

[0019] In this regard, the device comprises a body 2

exhibiting an end portion 21; the end portion 21, once the device 1 has been associated to the frame M of the automatic machine, faces towards a leather laid out on a plane, in which leather shapes having various profiles are to be cut.

[0020] In order to perform the cutting and/or perforating operations on the underlying leather, the body 2 can be activated in alternating translation, with respect to the frame M of the automatic machine, along a direction Z that is perpendicular to the leather.

[0021] The cutting device 1 of the present invention exhibits the particularity of further comprising an element 3, in the form of a drum, which exhibits an external peripheral surface 32, and is provided, along the external peripheral surface 32, with a series of housings. The drum element 3 is visible in detail, for example, in figures 2 and 3.

[0022] The element 3 is rotatably mountable on the end portion 21 of the body 2 in such a way that the relative external peripheral surface 32 can rotate about an axis C that is perpendicular to the end portion 21 (see for example figures 1 and 2).

[0023] The cutting device 1 of the present invention also exhibits a series of cutting tools 31; each of the cutting tools 31 being provided with a respective cutting edge having a relative profile that is different from the others, with each cutting tool 31 being mountable in a corresponding housing in the series of housings present in the external peripheral surface 32 of the drum element 3 such that the relative cutting edges are facing in an external direction.

[0024] A specific peculiarity of the device 1 of the invention consists in the fact that the drum-shaped element 3 is activatable in rotation about the axis C with respect to the end portion 21 of the body 2 such that a single cutting tool 31 at a time can be positionable facing the leather and the cutting edge thereof faces towards the leather in which a shape is to be cut.

[0025] In this way, according to the desired profile for the profile to be cut in the leather, with the device of the invention it is possible to select the correct cutting tool 31 rapidly and simply and without having recourse to halting the machine, i.e. the tool having a cutting edge with the profile corresponding to the shape which is to be realised in the leather.

[0026] To this end, it is sufficient simply to rotate the drum-shaped element 3 about the axis C up to positioning the cutting tool 31 in question in front of the leather.

[0027] In this regard, the device 1 exhibits a first actuator means 4, for example constituted by an encoder motor, which can be commanded, according to the profile desired for the shape to be cut in the leather, such as to activate the drum-shaped element 3 in rotation about the axis C with respect to the end portion 21 of the body 2 such as to bring one of the cutting tools 31 mounted on the element 3, having a corresponding desired profile for the shape to be cut, to face the leather and have the relative cutting edge positioned towards the leather.

[0028] The first actuator means 4 (encoder motor) is advantageously connectable to the control and management unit which is usually comprised in automatic machines for cutting shapes in the leathers, in which control and management unit the various profiles of the different shapes to be cut in the leathers are memorised.

[0029] Thus, on the basis of the data entered in the control and management unit, the first actuator means 4 can be commandable in real time such as to activate the rotation of the drum-shaped element 3 such that it can be set in rotation about the axis C up to positioning a desired cutting tool 31 in front of the leather in which the shape is to be cut. Once the desired cutting tool 31 has reached the position in front of the leather to be cut, the first actuator means 4 is deactivated and the rotation of the drum 3 halted.

[0030] The end portion 21 of the body 2, in the embodiment of the device illustrated in the accompanying figures of the drawings, and as clearly visible for example in figure 1, exhibits a fork shape having a pair of arms 22, 220 flanked to and distanced from one another.

[0031] The drum-shaped element 3 is mountable between the pair of arms 22, 220 and the first actuator organ 4, responsible for the rotating activation of the drum-shaped element 3, is predisposed internally of a first arm 220 of the pair of arms 22.

[0032] To facilitate the assembly operations, and possibly the replacement of the drum-shaped element 3 with another provided with further other different cutting tools T, or to enable removal from the drum-shaped element 3 of some cutting tools 31 to replace them with others, i.e. to enable maintenance operations of the first actuator organ 4, the first arm 220 of the pair of arms 20, 220 is mounted, with respect to the body 2, in such a way as to be removable from the body 2 (a situation for example illustrated in figure 2).

[0033] For the transmission of the rotating motion to the drum-shaped element 3, the device 1 comprises a pinion 48 mounted on the axis of the first actuator organ 4 and activatable in rotation thereby, and a cogged crown wheel 49, which is directly mounted on the drum-shaped element 3.

[0034] The pinion 48 couples to and meshes with the cogged crown wheel 49 (see for example figures 2 and 3) in order to enable transmission of the rotation from the first actuator means 4 to the drum-shaped element 3.

[0035] The cutting tools 31, which can be predisposed and mounted in the housings of the drum-shaped element 3, can comprise a relative closed-profile cutting edge, or a relative open-profile cutting edge, or both, and the cutting tools are usually internally hollow.

[0036] In the case of cutting tools 31 having a closed-profile cutting edge, when the leather is cut, the portion of leather that is circumscribed internally of the cutting edge of the tool can remain adhering thereto during the distancing step of the tool from the leather.

[0037] In this regard, in order to obviate the further drawback present at present in the cutting devices of

known type, the device 1 of the invention can advantageously exhibit a drum-shaped element 3 that is provided with a series of conduits 6 for passage of compressed air, with each of the conduits 6 leading respectively to each of the support housings of the cutting tools T, and, consequently, leading to the hollow internal part of the cutting tools 31 (see in particular figure 3).

[0038] Further, the device 1 can exhibit, internally of the end portion 21 of the body 2, a channel communicating with a source of compressed air, the communicating channel being connectable with a conduit 6 of the conduits 6 when a cutting tool 31 borne by the relative housing into which the conduit 6 leads is brought into a position with the relative cutting edge facing towards the leather in which a corresponding shape is to be cut, following the rotation of the drum-shaped element 3 about the axis C.

[0039] In this way, when a cutting tool 31, having the cutting edge with a profile corresponding to the profile of the desired shape to be cut in the leather, has been positioned following the rotation of the drum-shaped element 3 facing towards the leather, the conduit 6 connected thereto, and which is in communication with the hollow internal part of the cutting tool, is connected with the above-cited communication channel with the source of compressed air.

[0040] Consequently, at the same time as the cutting of the shape, compressed air can be injected into the communication channel, with the compressed air being thus conveyed into the hollow internal part of the cutting tool, reaching the end thereof in order to push the portion of cut leather, which is circumscribed internally of the relative cutting edge, to detach therefrom.

[0041] Other further characteristics of the cutting device 1 of the present invention are described in the following.

[0042] The device 1 comprises a structure 1 that supports the body 2 and further comprises second actuator means 41 (for example also constituted by an encoder motor connectable to the management and control unit present in the automatic machine to which the device is mounted) which are commandable in such a way as to be able to set the structure 60 in alternative translation, and thus the body 2 with the relative end portion 21 and the drum element 3, with the relative cutting tools 31, along the direction Z perpendicular to the leather in which the shapes are to be realised (see for example figure 1 or figure 7).

[0043] The second actuator means 41 is mounted and borne by a flange 8 which is fixable to the frame M of the automatic machine for cutting leathers on which the cutting device of the invention is to be used.

[0044] The structure 60, in the embodiment of the device illustrated in the accompanying figures of the drawings, comprises a plate 61, provided with an axial hole, and a threaded ring nut 63 which is fixed to the plate 61 coaxially to the through-hole.

[0045] As can be seen in both figure 1 and figure 7, a

screw 42 is insertable and rotatable in the through-hole and the threaded ring nut 63, the screw 42 being commandable in rotation by the second actuator means 41.

[0046] The structure 60 further comprises a cylindrical portion 65 borne by the plate 61, the cylindrical portion 65 being internally hollow and exhibiting a shape that is such as to be able to receive and support, internally thereof, a central part 28 of the body 2, the body 2 being mountable with the central part 28 thereof in the cylindrical portion 65, in such a way as to be set in rotation with respect to the cylindrical portion 65, with the relative end portion 21 and the drum-shaped element 3 mounted thereon, about a rotation axis T which is parallel to the alternative translation direction Z of the body 2, and perpendicular to the rotation axis C of the drum-shaped element 3 (see for example figure 1 and figure 6).

[0047] For this purpose, the device 1 comprises a third actuator means organ 68 (which can also be for example constituted by an encoder motor connectable to the control and management unit of the automatic machine) mounted on the plate 61 and being commandable such as to set the body 2 in rotation with respect to the cylindrical portion 65 about the rotation axis T.

[0048] In this regard, in the illustrated embodiment of the accompanying figures of the drawings, the cutting device 1 comprises a pulley 70 which is mounted on the body 2 at a relative end portion 27 thereof, opposite the end portion 21, and a belt 29, which winds on the pulley 70, which belt 29 is activatable by the third actuator means 68 such as to activate the rotation of the body 2 about the rotation axis T.

[0049] A casing 80 is provided, which is couplable to the structure 60 for covering and protecting the screw 42, pulley 70, belt 29 and end portion 27 of the body 2.

[0050] The cutting device 1 is further provided with a flat abutting element 88 of the leather; the flat element 88 is mounted relatively translatingly, by means of an interposing of compressible elastic organs 880 (for example springs), to the external end of the end portion 21.

[0051] The flat element 88 exhibits a through-slot 89 for enabling free passage of the cutting edge of one of the tools 31 when the cutting edge is positioned facing the leather following the rotation of the drum-shaped elements 3.

[0052] Once the control and management unit of the automatic machine has selected the profile of the shape which is to be realised in the leather, and the frame M of the machine has been translated above the leather in the position in which the profile is to be cut, the first actuating means 4 is commanded to set the drum element 3 in rotation about the axis C up to when the cutting tool 31 mounted thereon, having the appropriate cutting edge, is positioned facing and turned towards the leather.

[0053] The third actuating means 68 is then commanded such as to set the screw 41 in rotation, and consequently to set the plate 61 of the structure 60, and therefore the body 2 of the device 1, to translate according to the direction Z towards the leather up to when the flat

element 88 contacts with and rests against the surface of the leather.

[0054] The third actuator means 68 is however commanded to continue to translate the body 2 towards the leather, which determines a compression of the elastic organs 880, up to when the cutting edge of the cutting tool 31 inserts in the slot 89 present in the flat element 88 and passes through the leather by cutting a shape in it.

[0055] During the crossing of the leather by the cutting edge 31 the flat element 88, pressed against the leather, ensures that the leather, in the zone involved in the cutting, remains perfectly stretched.

[0056] As mentioned above, during the cutting step of the leather by the cutting tool 31, compressed air can be supplied internally of the communicating channel which is connected with the conduit 6 which, by means of the hollow internal part of the cutting tool, reaches up to the end thereof.

[0057] In this way, the shape of the cut leather which remains circumscribed within the edge of the cutting tool is detached therefrom when the body 2 is translated along the direction Z distancingly from the leather.

[0058] Thus, on the basis of the foregoing, the cutting device 1 can be fixable, by means of the flange 8, to a frame M of an automatic machine for cutting profiles in leathers.

[0059] The frame M, which is mobile with respect to the plane on which the leather is laid out, can be activatable such as to bring the cutting device 1 to one or more positions in which one or more shapes exhibiting profiles that are different to one another are to be cut.

[0060] Once the device has been positioned in the desired position, or also while the device is translated by means of the frame M towards the desired position, the first actuator means 4 can be activatable such as to rotate the drum-shaped element 3 in order for the cutting tool 31, having the cutting edge with the profile corresponding to the profile of the shape which is to be cut in the leather, to be positioned facing towards the leather.

[0061] Once the cutting device 1 has been positioned as desired, and the drum-shaped element 3 has been rotated such as to select the cutting tool 31 desired, the third actuating means 68 can be commandable to impose on the body 2, via the rotation of the screw 42 in the above-described ways, a translation along the direction Z perpendicularly towards the leather up to when the cutting edge of the tool has passed beyond the leather, cutting therein a corresponding shape.

[0062] According to the complexity of the figures and profiles of the shapes to be obtained in the leather, for example should it be desired to have a particular orientation for the shapes, before the translating step of the selected cutting tool towards the leather, the second actuator means 68 can be commandable such as to set the body 2, by means of the rotation of the pulley 70, in rotation about the axis T such as to angularly orientate the cutting edge of the cutting tool 31 with respect to the leather, in the orientation desired for the shape to be ob-

tained.

[0063] From the above description, the advantages of the device of the present invention are obvious: in fact, differently to the prior art, no machine halting is required in a case where cutting of shapes having different profiles in the leather is necessary.

[0064] For this purpose, it will be sufficient to activate the rotation of the drum-shaped element 3 up to positioning the cutting tool 31, having the desired profile, facing towards the leather.

[0065] Further, thanks to the presence of the second actuator means 68, and thanks also to the possibility of setting the body 2 in rotation about the axis T, and therefore also the drum-shaped element 3 and the cutting tool 31 selected for the cutting operations, it is easily and rapidly possible to angularly orientate the cutting edge of the tool in the desired position with respect to the leather.

[0066] The foregoing has been described by way of non-limiting example, and any eventual constructional variants are understood to fall within the ambit of the following claims.

Claims

1. A cutting device for cutting shapes in leathers, suitable for mounting in machines for cutting leathers, the device (1) comprising a body (2) exhibiting an end portion (21), the end portion (21) facing towards a leather laid on a plane, in which leather shapes having various profiles are to be cut once the device (1) has been associated to a frame (M) of an automatic machine for cutting leathers, the body (2) being activatable in alternating translation with respect to the frame (M) of the automatic machine along a direction (Z) which is perpendicular to the leather, the device (1) being **characterised in that** it further comprises:

a drum-shaped element (3) exhibiting an external peripheral surface (32), the element (3) being provided, along the said external peripheral surface (32), with a series of housings, and being rotatably mountable on the end portion (21) of the body (2) such that the external peripheral surface (32) thereof can rotate about an axis (C) which is perpendicular to the end portion (21); a series of cutting tools (31), each of which is provided with a respective cutting edge, having different profiles from one another, each of which cutting tools (31) is mountable in a corresponding housing of the series of housings present in the external peripheral surface (32) of the drum-shaped element (3) such that the cutting edges thereof face in an external direction, and **in that** the drum-shaped element (3) is activatable in rotation about the axis (C) with

- respect to the end portion (21) of the body (2) such that a single cutting tool (31) at a time can be positionable facing the leather and the cutting edge thereof faces towards the leather in which a shape is to be cut.
2. The device of claim 1, **characterised in that** it comprises a first actuator means (4) which is commandable, according to a desired profile for the shape to be cut in the leather, to activate the drum-shaped element (3) in rotation about the axis (C) with respect to the end portion (21) of the body (2) such as to bring one of the cutting tools (31) mounted on the element (3), having a corresponding desired profile for the shape to be cut, to face the leather and have the relative cutting edge positioned towards the leather.
 3. The device of claim 2, **characterised in that** the end portion (21) of the body (2) exhibits a fork-shape having a pair of arms (22, 220) flanked to one another and reciprocally distanced, and **in that** the drum-shaped element (3) is mountable between the pair of arms (22, 220) and **in that** the first actuator means (4) is predisposed internally of a first arm (220) of the pair of arms (22, 220).
 4. The device of claim 3, **characterised in that** the first arm (220) of the pair of arms (20, 220) is removable with respect to the body (2) in such a way as to enable mounting and demounting of the drum-shaped element (3) and the first actuator means (4).
 5. The device of claim 3, **characterised in that** it comprises a pinion (48), activatable in rotation by the first actuator means (4), and a cogged crown wheel (49) associated to the drum-shaped element (3), the pinion (48) coupling with the cogged crown wheel (49) in order to enable transmission of the rotation from the first actuator means (4) to the drum-shaped element (3).
 6. The device of claim 1, **characterised in that** the drum-shaped element (3) is provided with passage conduits (6) for compressed air, each of which conduits (6) respectively leads into each of the support housings of the cutting tools (T), and **in that** it comprises a communication channel with a source of compressed air, realised in the end portion (21) of the body (2), the communication channel being connectable with a conduit (6) of the conduits (6) when a cutting tool (31) inserted in the relative housing into which the conduit (6) leads is brought into a position with the cutting edge thereof facing towards the leather in which a shape is to be cut, following a rotation of the element (3) about the axis (C).
 7. The device of claim 1, **characterised in that** it comprises a structure (60) which supports and sustains the body (2) and **in that** it comprises a second actuator means (41) commandable to set the structure (60) and therefore the body (2) with the relative end portion (21) and the drum-shaped element (3) with the relative cutting tools (31) mounted on the end portion (21), in alternating translation along the direction (Z) perpendicularly to the leather in which the shapes are to be realised, the second actuator means (41) being borne by a flange (8) which is fixable to the frame (M) of an automatic machine for cutting leathers.
 8. The device of claim 7, **characterised in that** the structure (60) comprises a plate (61), provided with a through-hole, and a threaded ring nut (63) fixed to the plate (61) coaxially to the through-hole, a screw (42) being insertable and rotatable in the through-hole and the threaded ring-nut (63), the screw (42) being commandable in rotation by the second actuator means (41).
 9. The device of claim 8, **characterised in that** the structure (60) further comprises a cylindrical portion (65) borne by the plate (61), the cylindrical portion (65) being internally hollow and having such a shape as to be able to receive and support, internally thereof, a central part (28) of the body (2), the body (2) being mountable with the central part (28) thereof in the cylindrical portion (65) in such a way that the body (2), with the relative end portion (21) and the drum-shaped element (3) mounted thereon, can be set in rotation with respect to the cylindrical portion (65) about a rotation axis (T) which is parallel to the alternating translation direction (Z) of the body (2), and perpendicularly to the rotation axis (C) of the drum-shaped element (3).
 10. The device of claim 9, **characterised in that** it comprises a third actuator means (68) mounted on the plate (61) and commandable to set the body (2) in rotation with respect to the cylindrical portion (65) about the rotation axis (T).
 11. The device of any one of the preceding claims, **characterised in that** it comprises a flat element (88) for abutting the leather, the flat element (88) being mounted relatively translatingly, by interposing of compressing elastic means (880), to the external end of the end portion (21) and exhibiting a through-slot (89) for enabling free passage of the cutting edge of one of the tools (31) when the tool (31) is positioned facing the leather following the rotation of the drum-shaped element (3).

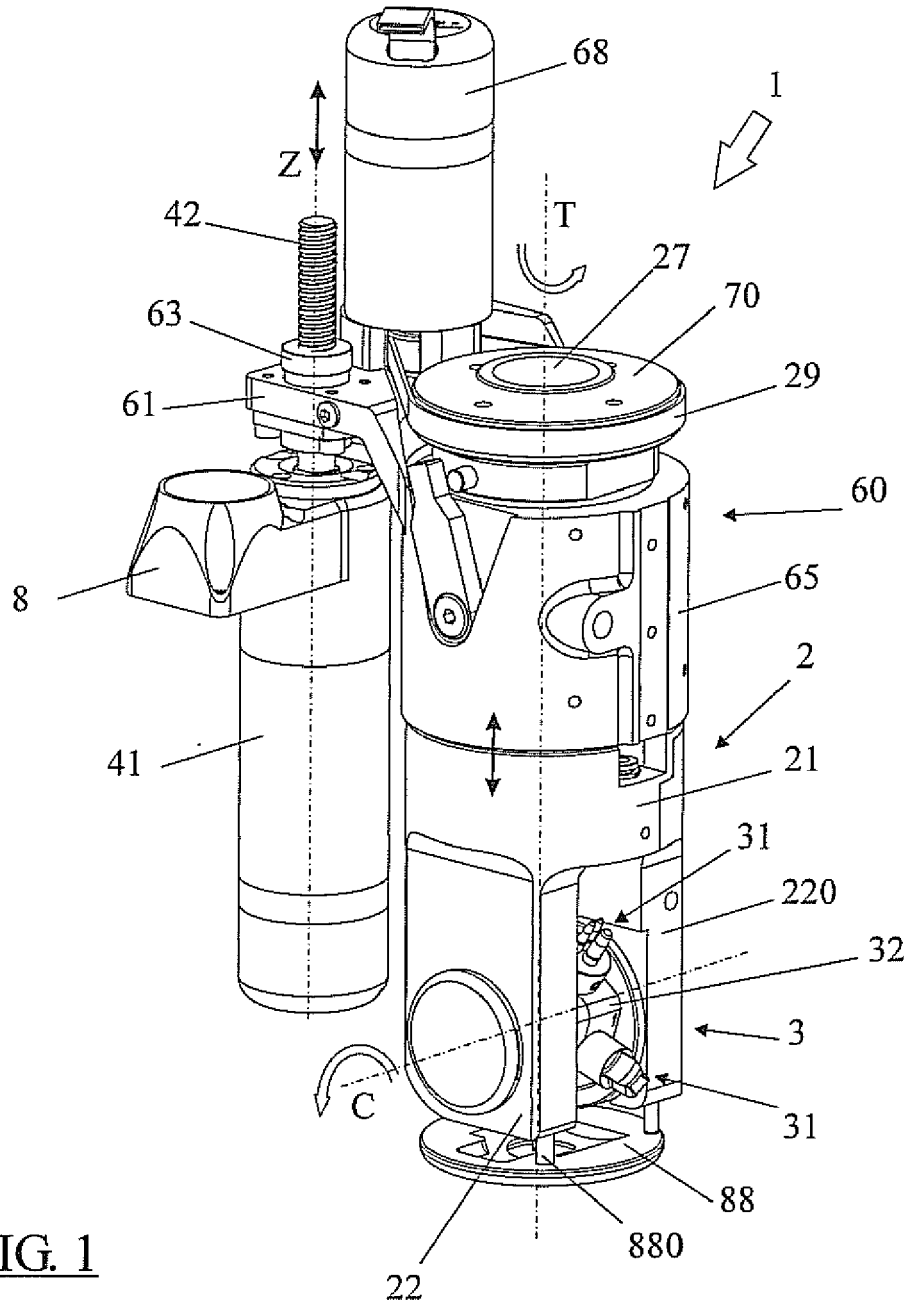

FIG. 1

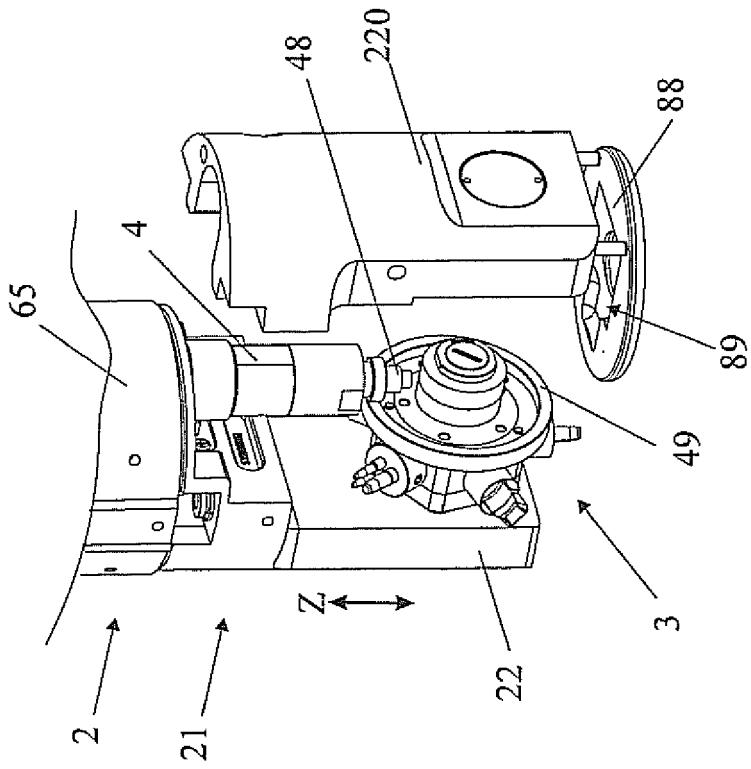

FIG. 2

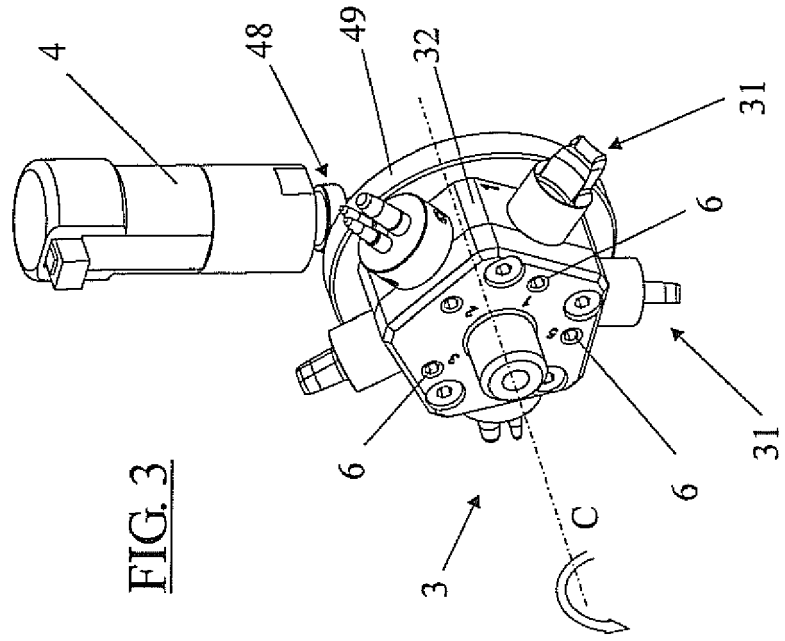
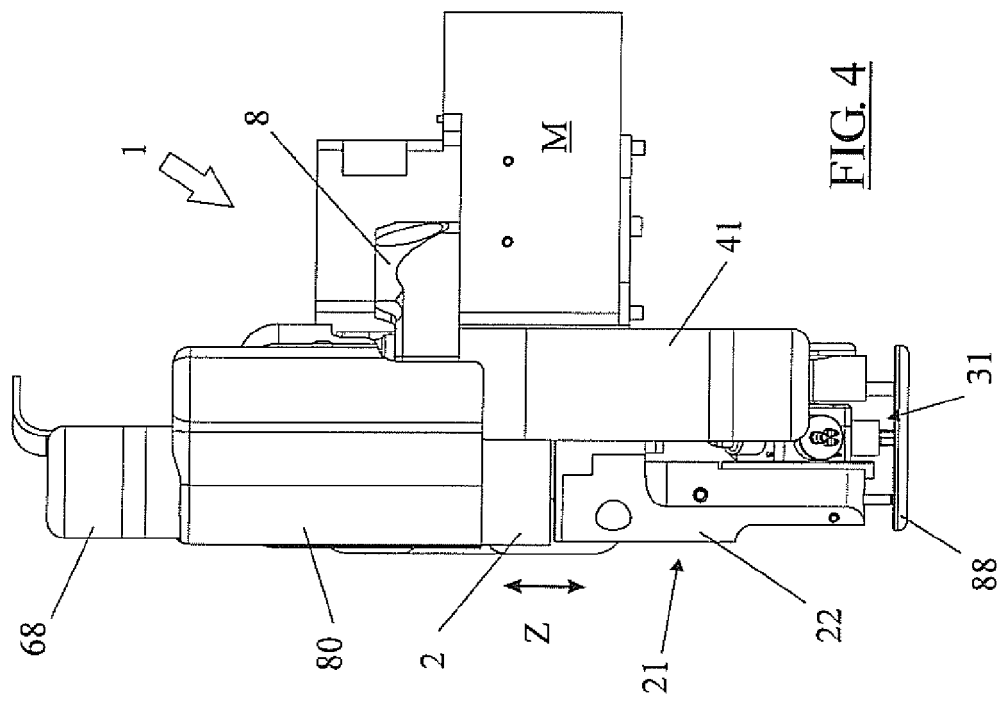
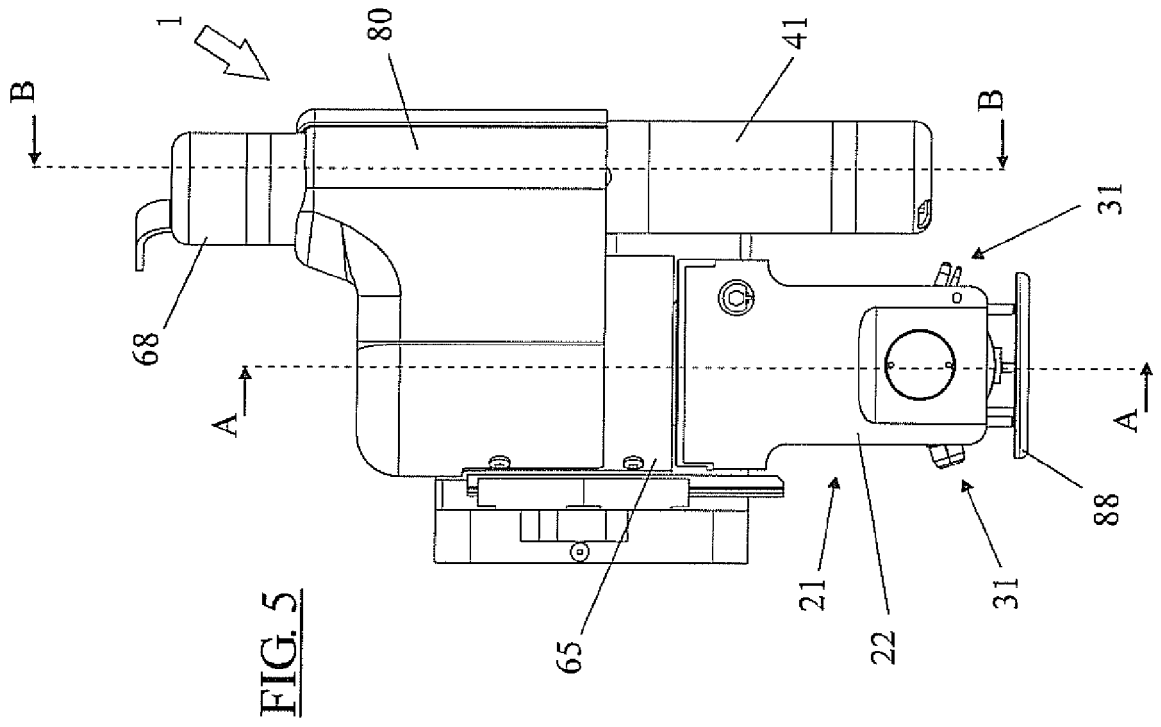
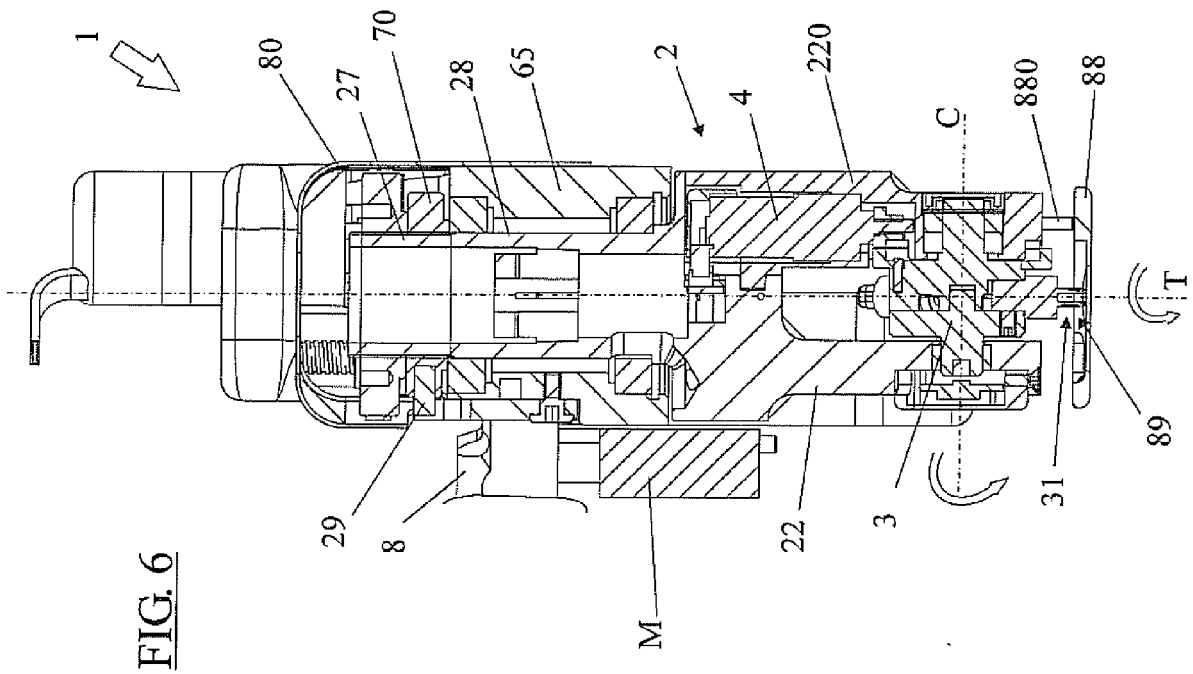
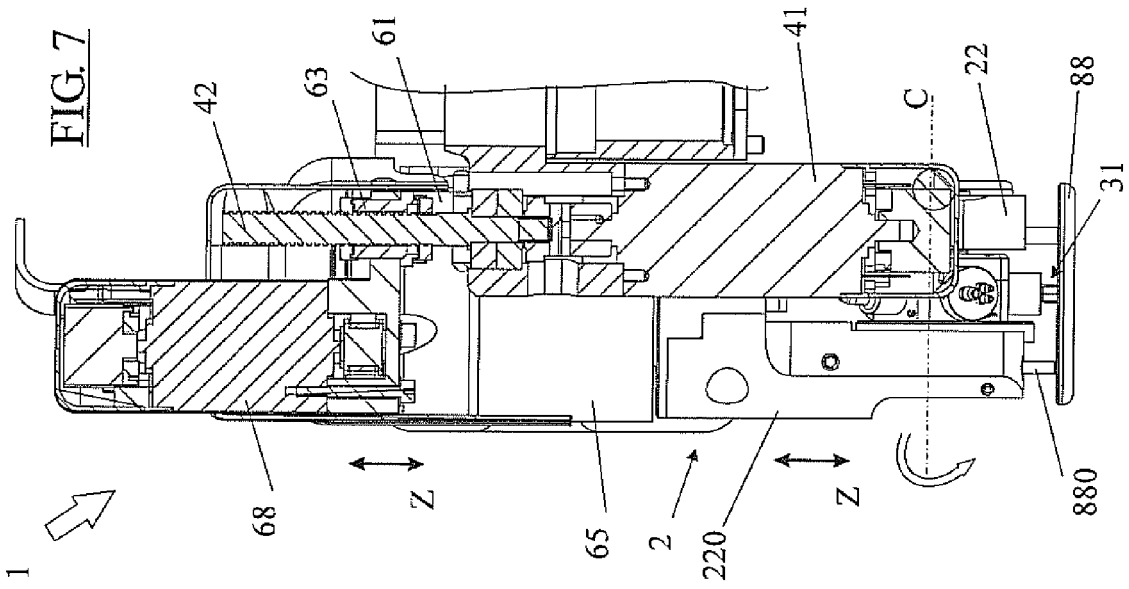

FIG. 3







EUROPEAN SEARCH REPORT

Application Number
EP 11 18 7900

DOCUMENTS CONSIDERED TO BE RELEVANT			
Category	Citation of document with indication, where appropriate, of relevant passages	Relevant to claim	CLASSIFICATION OF THE APPLICATION (IPC)
X	AU 90408 82 A (MILHAM W R) 28 July 1983 (1983-07-28) * the whole document *	1,2,11	INV. C14B5/00 B21D28/36 B26F1/04
X	US 1 407 769 A (ALEXANDER PREMO) 28 February 1922 (1922-02-28) * page 2, lines 15-37 * * page 3, lines 78-109; claim 1; figures 1-4,10 *	1-3,11	
A	GB 611 446 A (HARRY VERNON FOX) 29 October 1948 (1948-10-29) * the whole document *	1-11	
A	US 2008/314220 A1 (FERRY GREGORY S [US] ET AL) 25 December 2008 (2008-12-25) * the whole document *	1-11	
A	EP 0 875 310 A1 (EUROMAC SRL [IT]) 4 November 1998 (1998-11-04) * the whole document *	1-11	
A	GB 479 365 A (TUBULAR PERFORATING AND MACHIN) 4 February 1938 (1938-02-04) * page 3, line 95 - page 4, line 28; claim 1 *	1,6	
The present search report has been drawn up for all claims			TECHNICAL FIELDS SEARCHED (IPC)
			C14B B21D B26F
1	Place of search Munich	Date of completion of the search 29 November 2011	Examiner Bichi, Marco
CATEGORY OF CITED DOCUMENTS		T : theory or principle underlying the invention E : earlier patent document, but published on, or after the filing date D : document cited in the application L : document cited for other reasons & : member of the same patent family, corresponding document	
X : particularly relevant if taken alone Y : particularly relevant if combined with another document of the same category A : technological background O : non-written disclosure P : intermediate document			

EPO FORM 1503 03/02 (P04C01)

**ANNEX TO THE EUROPEAN SEARCH REPORT
ON EUROPEAN PATENT APPLICATION NO.**

EP 11 18 7900

This annex lists the patent family members relating to the patent documents cited in the above-mentioned European search report. The members are as contained in the European Patent Office EDP file on
The European Patent Office is in no way liable for these particulars which are merely given for the purpose of information.

29-11-2011

Patent document cited in search report	Publication date	Patent family member(s)	Publication date
AU 9040882	A	28-07-1983	NONE
US 1407769	A	28-02-1922	NONE
GB 611446	A	29-10-1948	NONE
US 2008314220	A1	25-12-2008	NONE
EP 0875310	A1	04-11-1998	AT 212884 T 15-02-2002
		BR 9801467 A	28-09-1999
		CN 1199656 A	25-11-1998
		DE 69803717 D1	21-03-2002
		DE 69803717 T2	01-08-2002
		EP 0875310 A1	04-11-1998
		ES 2167821 T3	16-05-2002
		GB 2324755 A	04-11-1998
		JP 10337696 A	22-12-1998
		TR 9800784 A2	21-10-1999
		US 6074330 A	13-06-2000
GB 479365	A	04-02-1938	NONE