

H. OGBORN.
Grain Winnower.

No. 100,552.

Patented March 8, 1870.

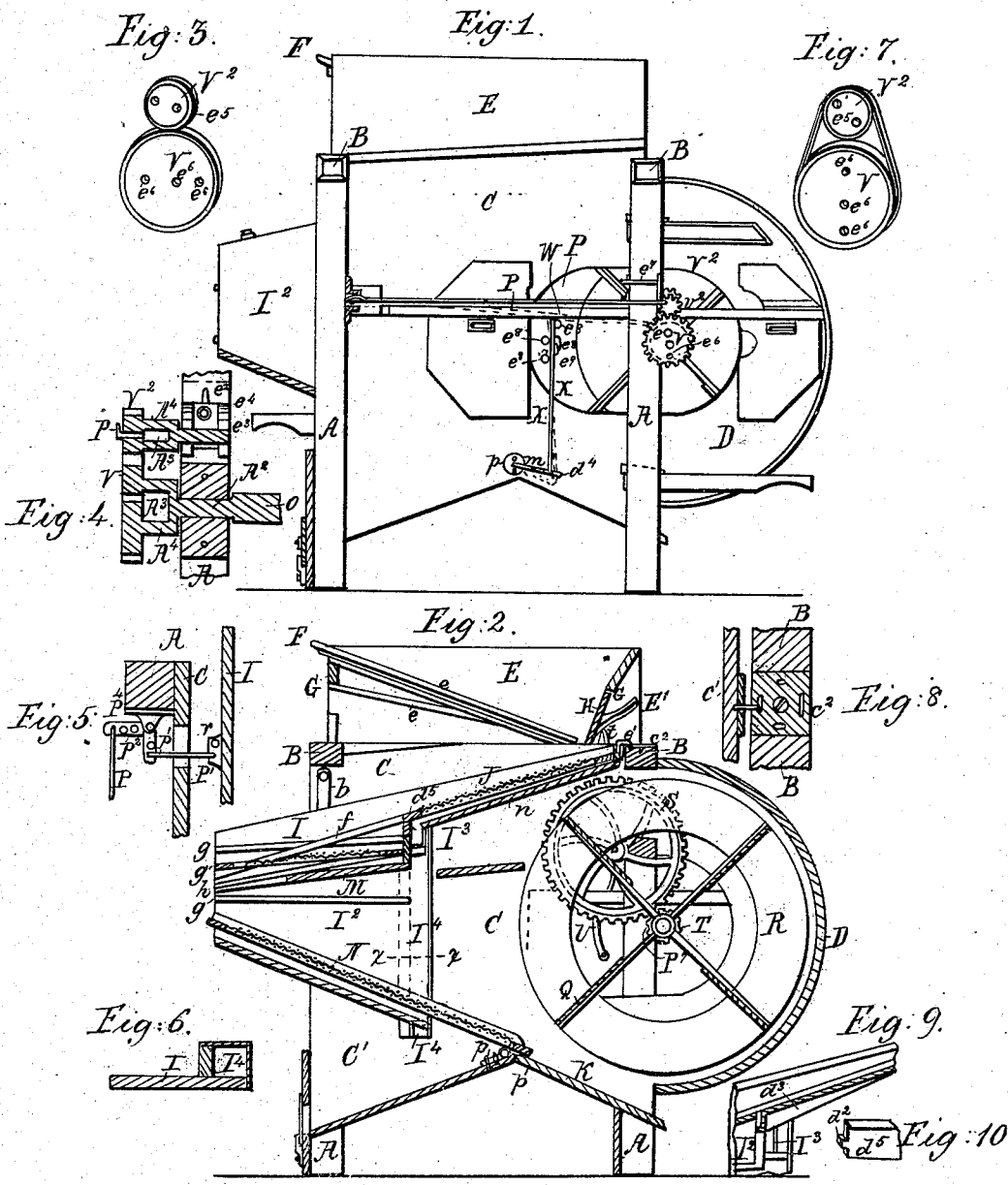

Witnesses:

Almas Roberts
C. H. Ferguson

Inventor:

Harrison Ogborn

United States Patent Office.

HARRISON OGBORN, OF RICHMOND, INDIANA.

Letters Patent No. 100,552, dated March 8, 1870.

IMPROVED FANNING-MILL AND GRAIN-SEPARATOR.

The Schedule referred to in these Letters Patent and making part of the same.

To all whom it may concern:

Be it known that I, HARRISON OGBORN, of Richmond, in the county of Wayne, and State of Indiana, have invented new and useful Improvements in Combined Fanning-Mill, Grain and Seed-Separator; and I do hereby declare the following to be a full and clear description of the same, sufficient to enable others skilled in the art to which my improvement appertains to fully understand and use the same, reference being had to the accompanying drawings making part of this specification, in which—

Figure 1 is a side elevation of my improved machine.

Figure 2 is a sectional view of the same.

Figure 3 is a view of the friction-pulleys.

Figure 4 is a sectional view of the pinion-wheels, pulley-wheels, and friction-wheels, together with their bearings and open shafts.

Figure 5 is the bell-crank with its rods and attachments.

Figure 6 is a section of the spout that carries the chess and other impurities to the chess-box.

Figure 7 is a view of pulleys when run with a belt.

Figure 8 is a top view of the shoe, hook, and slotted plate for holding the same.

Figure 9 is a view of a section of the shoe-trough and vertical groove.

Figure 10 is a view of the piece for opening and closing the trough in the "shoe."

Similar letters indicate corresponding parts in the different figures.

The nature of my invention consists—

First, in the use of vertical grooves in the shoe, and in tenoned board fitting in the same, in different positions, for opening and closing the trough in the shoe.

Secondly, in devices for holding or hanging the upper end of the "shoe" to allow of more or less lateral motion of the same.

Thirdly, in devices for allowing of the attachment of the short shaker-rod to different places on the shoe, so that the power may be applied to shake centrally or bodily, shown at *r*, fig. 5.

Fourthly, in devices for operating a knocker to keep the screens clean.

Fifthly, the use of a hollow open shaft for wheel and pinion at outside of fan-case, to permit the long rod to be more centrally attached to the pinion or crank-wheels, so as to give a shorter shake of the shoe than has been heretofore possible.

Sixthly, in devices for giving increased motion to a shoe of a grain-cleaner without increasing the revolutions of the fan-shaft, consisting of an extra or supplemental wheel or disk.

A A in my drawings represent the upright frame of a fanning-mill supporting the cross-pieces B B and the sides C and drum D.

Secured to the cross-piece B are the boards E provided on their inner surface with grooves, *e e*, in which the board F slides, and securely held together by the cross-piece G over the top, and under the bottom of which the grooves *e e* run, coming together in front at an angle so that the board F has more slant in the upper groove than in the lower one.

Pivoted at its top to the front of the hopper E, at *a*, is the swing-board H, which is adjusted by a cam-lever, F¹, and spur, pivoted at its front side, as shown in fig. 2.

I, figs. 1 and 2, is a vibrating "shoe" hung at the rear by straps *b*, and in front on hooks *c*¹ and slotted plate *c*².

The sides of the shoe I are provided with different sets of grooves, *f*, running the entire length of the "shoe" to its front end, the grooves *g g* and *h* running to the end of the part I² in the grooves *f* slides the screen J, which is generally a fine-meshed one, the groove *h* holds the chess-board M, and the other grooves are used as they are needed for different kinds of grain and seeds. The screen N is supported at its rear end by pins on its sides near its upper end catching in ratchets, its front or lower end resting on its bent portions of *p*¹ inside the "shoe" of a rod *p*, as shown in fig. 2. The screen J is held in position by a hook or any other convenient device, and the other screens and board are held by a rod passing through them at one edge and through staples on the inside of the "shoe."

At the upper or inner end of part I² of the shoe I is placed a sloping bottom trough, I³, across the entire width of the "shoe," its lower end connecting at the side of the "shoe" with the spout I⁴, as shown in fig. 2, and directly under the lower end of screen J, so that the small seeds, chess, and other impurities falling through the screen J upon the upper grain-board are shaken into the trough I³ and run from it into the spout I⁴ and fall into the chess-box C.

The rear-side board of the trough I³, figs. 9 and 10, is made adjustable by having a square tenon, *d*², on its ends, which fits into vertical grooves, *d*¹, for holding the piece *d*² with its sides vertical, when the screw J is used, thus forming a trough also for holding it in a nearly horizontal position, thus shutting up the box, and making a continuous grain-board to be used when cleaning small grain and seeds when screen J is not used.

Inside the drum D rotates the fan, its shaft having its bearings on standards A A, and provided with arms P⁷ to which wings Q are attached. At its center it is provided with a circular rim, R, which acts as a guide to the currents of air coming in on each side of the drum, partially changing their direction, and causing the air to pass out in an even continuous blast.

At one side of the mill, inside of the drum D, is situated a gear-wheel, S, giving motion to the shaft

o and fan-wings, pulley, and shoe, by means of the pinion T and operated by the handle U.

At the opposite side, just outside of the bearings, a gear, belt, or friction-wheel, V V V, is placed, as shown at V in figs. 1, 3, 4, and 7, for giving motion to the shoe through the rods P and P¹, and bell-crank P¹ being rigidly attached to the fan-shaft, as shown at fig. 4, at A², and provided with an open shaft, as shown at A³, fig. 4, to allow the bent end of the long rod P to pass into the holes e⁶ in the wheel V nearer its center than would be possible with a solid shaft, thus producing a smaller or lighter shake or vibration of the shoe than is otherwise attainable as ordinarily constructed.

Immediately above this wheel V is placed a disk or wheel, V², which may be run or rotated upon its axis by a cog-gear, friction-pulley, by a belt, or otherwise. This pulley-wheel V² is fixed on a shaft, e², held in bearings e¹ parallel with the fan-shaft; these bearings may be raised or lowered at pleasure by means of a bolt, e⁷, which holds it in position, sliding up and down in a slot, e⁸, in the post A, fig. 4, thus allowing it to be thrown in or out of mesh, and also allowing pinions of different sizes to be used to still further increase or diminish its motions relatively to the wheel V. This pulley or wheel has holes in its face, as shown at e⁹, to receive one end of the long rod when taken out of wheel V to increase the number of vibrations of the "shoe" without increasing the revolutions of the fan-shaft; the number of vibrations may thus be increased to almost any extent.

Attached to the rod P is a wire, W, which has two eyes or points of attachment, as in fig. 1 at e⁵. To this rod W the upper end of rod X hooks, as shown at e³, fig. 1; this rod X hooks into the bent part m of the knocking-rod p, as shown in fig. 1 at d⁴, for shaking the same by means of the vertical motion of rod X given to it by the long rod P. When the rod P is attached to the wheel V the rod X is attached to the upper eye of rod W, and when the rod P is attached to the wheel V² the rod X is attached to the lower eye of rod W, thus making the action of rod X always the same on rod m. The rod m is provided with holes at different distances from the end, to allow of different degrees of motion being given to rod p, as may be desired.

At C' is a large chess-box, opened or closed at the rear by any convenient device.

The sliding-doors over the wind-holes in the drum are provided with cleats which rest on bars on the machine, and are held in any position desired by points in said cleats dropping or projecting into the bars, thus preventing the accidental displacement of the same.

To clean wheat, pour it into the hopper E on the hopper-bottom F, on which, by reason of its being nearly the same width of the "shoe," the grain is spread out, and delivered in a thin, wide, even sheet on to the screens, the rear opening being adjusted and

regulated by the swing-board H and lever E'. It may be held in any desired position by turning the lever down, which brings the lower end of it against the grooved plate t in the side of the hopper E, and to feed faster than the utmost swinging of the board H will allow, it is only necessary to draw the board out in the grooves.

The screen J is so placed that when the grain falls upon it, most of the chaff, cockle, and other impurities pass through the screen J and fall upon the upper grain-board n, and are carried into the trough I³ from which they are shaken through the spout I⁴ into the chess-box C'. The wheat passes on to the coarse screens which take out the coarse large particles, and allow the wheat to fall on to the chess-board. This board is provided with several holes, by means of which it may be adjusted nearer to or further from the rear end of the shoe, so that, as the grain falls from the board to the screen N, the wind strikes it for the first time, and blows out most of the remaining impurities.

The grain has now fallen on to the lowest screen N, which is constantly shaken laterally by the "shoe," and vertically by the rod p. If any impurities still remain they are sifted and jolted through the meshes of the screen into the chess-box, while the pure wheat is carried over the screen N and lower grain-board K on to the floor or into a box placed to receive it.

To clean small seeds, the screen J is taken out, the adjustable part of the trough I³ placed horizontal, thus forming a continuous upper grain-board, and the proper screens placed in their respective places by means of the devices described. Very superior results are thus obtained.

Having thus described my invention,

What I claim therein as new and useful, and desire to secure by Letters Patent, is—

1. The trough I³ and screen J, in combination with the tenoned piece d⁵ and spout I⁴, when used together for the purposes and in the manner described.
2. The open or slotted shafts A³, when used for the purposes and in the manner set forth.
3. The double eye r and rod P¹, in combination with the hook e¹ and plate e², when used together for the purposes and in the manner set forth.
4. The rods W and X, in combination with rod m and P, when attached and used together, for the purposes and in the manner set forth.
5. The hook e¹ and adjustable slotted plate e², or their equivalents, when used for the purposes set forth.
6. Providing a pinion V², or its equivalent, with an adjustable journal-box or bearing, when used for the purpose of varying and regulating the speed of motion of the "shoe" in a grain or seed-cleaner, substantially in the manner and for the purposes herein set forth.

Witnesses: HARRISON OGBORN.

ARTEMAS ROBERTS,
C. W. FERGUSON.