

(12) INTERNATIONAL APPLICATION PUBLISHED UNDER THE PATENT COOPERATION TREATY (PCT)

(19) World Intellectual Property Organization
International Bureau



(43) International Publication Date
28 November 2002 (28.11.2002)

PCT

(10) International Publication Number
WO 02/095940 A1

- (51) International Patent Classification⁷: **H03H 9/25**, 9/64
- (21) International Application Number: PCT/AU02/00616
- (22) International Filing Date: 20 May 2002 (20.05.2002)
- (25) Filing Language: English
- (26) Publication Language: English
- (30) Priority Data:
PR 5076 21 May 2001 (21.05.2001) AU
- (71) Applicant (for all designated States except US): **MI-CROTECHNOLOGY CENTRE MANAGEMENT LIMITED** [AU/AU]; William St, Hawthorn, Victoria 3122 (AU).
- (81) Designated States (national): AE, AG, AL, AM, AT, AU, AZ, BA, BB, BG, BR, BY, BZ, CA, CH, CN, CO, CR, CU, CZ, DE, DK, DM, DZ, EC, EE, ES, FI, GB, GD, GE, GH, GM, HR, HU, ID, IL, IN, IS, JP, KE, KG, KP, KR, KZ, LC, LK, LR, LS, LT, LU, LV, MA, MD, MG, MK, MN, MW, MX, MZ, NO, NZ, PH, PL, PT, RO, RU, SD, SE, SG, SI, SK, SL, TJ, TM, TR, TT, TZ, UA, UG, US, UZ, VN, YU, ZA, ZW.
- (84) Designated States (regional): ARIPO patent (GH, GM, KE, LS, MW, MZ, SD, SL, SZ, TZ, UG, ZM, ZW), Eurasian patent (AM, AZ, BY, KG, KZ, MD, RU, TJ, TM), European patent (AT, BE, CH, CY, DE, DK, ES, FI, FR, GB, GR, IE, IT, LU, MC, NL, PT, SE, TR), OAPI patent (BF, BJ, CF, CG, CI, CM, GA, GN, GQ, GW, ML, MR, NE, SN, TD, TG).

Declaration under Rule 4.17:

— of inventorship (Rule 4.17(iv)) for US only

Published:

— with international search report

For two-letter codes and other abbreviations, refer to the "Guidance Notes on Codes and Abbreviations" appearing at the beginning of each regular issue of the PCT Gazette.

- (72) Inventors; and
- (75) Inventors/Applicants (for US only): **KALANAR-ZADEH, Kourosh** [AU/AU]; School of Electrical & Computer Engineering, RMIT, 124 Latrobe Street, Melbourne, Victoria 3000 (AU). **WLODARSKI, Wojtek** [AU/AU]; School of Electrical & Computer Engineering, RMIT, 124 Latrobe Street, Melbourne, Victoria 3000 (AU).
- (74) Agent: **MISCHLEWSKI, Darryl**; P.O. Box 1254, Camberwell, Victoria 3124 (AU).

(54) Title: SURFACE ACOUSTIC WAVE SENSOR

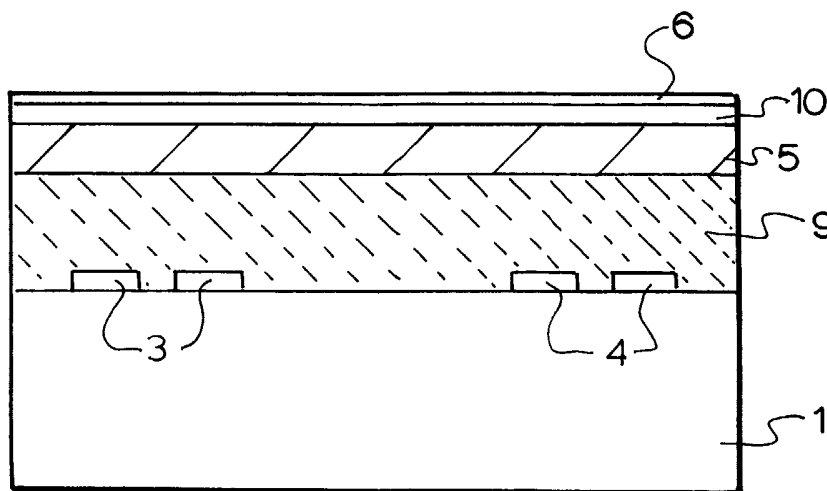

(57) Abstract: A surface acoustic wave sensor is provided having a piezoelectric material deposited on a piezoelectric substrate. The preferred structure is zinc oxide on ST-cut quartz crystals that allows propagation of a Love mode acoustic wave and is particularly useful in liquid media as well as gas. The sensor can be used to detect biological or chemical moieties.



WO 02/095940 A1

Surface Acoustic Wave Sensor

5 This invention relates to improvements in Surface Acoustic Wave [SAW] devices and particularly SAW devices used as sensors.

Background to the invention

SAW devices have been used as sensors in liquid and gaseous environments.

10 USA patent 4562371 discloses a SAW device comprising a ZnO piezo layer on a cut crystalline silicon substrate that propagates Rayleigh waves.

The surface acoustic waves propagate in 3 directions and can be classified as longitudinal wave motion, Normal waves or shear horizontal waves. A class of shear horizontal [SH] waves are called Love waves which are propagated in
15 layered devices that concentrate the wave energy in a highly confined region near to the surface.

Rayleigh wave sensors have been useful in gaseous environments but they are not suitable for liquid environments because the surface-normal displacement causes strong radiative loss into the liquid. For sensing in liquids shear horizontal
20 [SH] polarised wave modes are preferred since the particle displacement is parallel to the device surface and normal to the direction of propagation. This allows a wave to propagate in contact with a liquid without coupling excessive acoustic energy into the liquid. However the SH wave is distributed through the substrate and therefore does not have the same sensitivity as the SAW. For
25 increased sensitivity Love waves which are SH-polarised guided surface waves may be used. The waves propagate in a layered structure consisting of a piezoelectric substrate and a guiding layer which couples the elastic waves generated in the substrate to the near surface. They are extremely sensitive to surface perturbations due to the energy confinement to the near surface. By
30 observing the magnitude of perturbations it is possible to measure the strength of the interaction. The interactions may be caused by mass density, elastic stiffness, liquid viscosity, electric and dielectric properties. The more sensitive is the device the smaller the quantities that can be measured.

USA patents 5130257, 5216312, 5283037 and 5321331 disclose love mode SAW
35 sensors used in liquid environments. The love waves are produced by cutting the

piezo electric material such as lithium niobate, lithium tantalate or quartz to couple energy from the interdigital transducers [IDT's] of the SAW device into shear transverse or love waves that enable the wave energy to be trapped at the substrate surface.

5 USA patent 5705 399 discloses a SAW sensor for liquid environments having an AT cut quartz piezo substrate with electrodes connected to a first side in contact with a liquid and a second side that is not in contact. The sensor may be used to detect biological species such as antigens.

USA patent 5364797 discloses the use of a porous material as a surface layer of
10 high surface area for SAW devices.

Porous surfaces are used in gaseous environments to increase the contact surface area and consequently the sensitivity of the device. Porous surface have not been used in liquid media because the porous surface increases viscosity which leads to insertion losses and decreasing sensitivity.

15 It is an object of this invention to improve the sensitivity of SAW sensors particularly in liquid media.

Brief Description of the Invention

To this end the present invention provides a surface acoustic wave sensor which includes a piezoelectric layer on a piezoelectric substrate.

20 Preferably the piezoelectric substrate is cut for propagation of love mode waves. Preferably the piezoelectric layer is porous.

This structure provides the following advantages:

- 1- High Electromechanical Coupling Coefficient (K^2).
- 2- Small Temperature Coefficient.
- 25 3- High confinement of energy on the surface.
- 4- Ability of the device to operate in liquid media with a porous surface.

The Piezo substrate may be quartz crystal, lithium Niobate [LiNbO_3] or lithium tantalate [LiTaO_3].

A preferred piezo substrate is 90° rotated ST-cut quartz crystal which has a
30 propagation speed of 5000m/s and the dominant wave is SSBW and has zero coupling to other modes. It is dominantly a Shear Horizontal [SH] bulk wave and has a low temperature coefficient. Its major disadvantage is a high insertion loss as it changes from SSBW to love mode. When a film material is deposited on the surface it should load the substrate which means the speed of propagation in the

film is less than in the substrate. In this case the mode of propagation changes to love mode. When metal oxides films are deposited on the substrate the insertion loss is decreased as the mode of operation changes from SSBW to Love mode. Its main advantage is a lower insertion loss as it decreases from SSBW to Love mode.

The preferred porous piezoelectric material is a layer of zinc oxide which is a porous surface formed by hexagonal pillars. ZnO is the best candidate for fabricating Love mode devices. It has a porous surface and is a piezoelectric material with a low phase velocity (2650 m/s). This implies that ZnO can increase the electromechanical coupling coefficient more than other deposited materials. Furthermore, ZnO consists of hexagonally shaped cylinders with gaps in between them, making the guiding layer porous. ZnO has a positive temperature coefficient whereas 90° rotated ST-cut quartz crystal has a negative temperature coefficient. The combination of positive and negative temperature coefficients assists to reduce the temperature coefficient of the whole structure. Around room temperature (25°C) the temperature coefficient remains relatively lower than that of the blank SSBW structures.

A biologically sensitive layer may be deposited on the piezo layer to interact with the appropriate biochemical components to be detected. A gold film may be deposited on the surface. Gold interacts with high affinity to proteins. It can be used with specific antibodies for antigen detection. This deposit can be made on a porous surface as well as a smooth surface.

1. In a further aspect the present invention provides a sensor for use in detecting chemical or biochemical moieties in gaseous or liquid mediums which incorporates a surface acoustic wave device which consisting of
 - a substrate of a piezoelectric quartz crystal
 - at least one interdigital transducer formed on said quartz crystal
 - a piezoelectric film of zinc oxide deposited on said crystal and transducer
 - a biologically sensitive layer deposited on said zinc oxide layer

An important advantage of the present invention is the sensitivity of of the sensor. The mass detection limit is $100\text{pg}/\text{cm}^2$ which is at least 10 times more sensitive than sensors using other substrates and 2to3 times more sensitive than quartz crystals with a non piezo layer such as SiO_2 .

5

Detailed description of invention

Figure 1 is a schematic illustration of a SAW device of this invention;

Figure 2 is a cross section of another embodiment of the invention;

Figure 3 is a perspective view of a further embodiment including a second set of
10 wave generating and receiving acoustic transducers;

Figure 4 is a schematic illustration of a preferred sensor and analyser of this invention;

Figure 5 is a comparison of the coupling coefficient for ZnO and SiO_2 films on an ST-cut quartz crystal wafer;

15 Figure 6 illustrates the response of the sensor of this invention to a sequence of different solutions.

Fig. 7 illustrates the response of the sensor of this invention to a sequence of 100 ppm O_2 in N_2 .

20 Fig. 8 illustrates the frequency shift of the sensor of this invention exposed to different oxygen concentrations.

This invention provides piezoelectric layers on piezoelectric substrates. The Substrate's cut belongs to a class of crystal cuts that support Surface Skimming Bulk Wave (SSBW). The layers are of different of piezoelectric materials that can
25 be deposited as a highly directional film on the substrate, which let acoustic waves propagate on shear horizontal direction. Speed of propagation of acoustic wave in the layers must be less than the substrate to support Love mode of propagation.

In figure 1 a first wave generating transducer 3 and a first receiving transducer 4
30 are fabricated onto the surface of a piezoelectric substrate 1. The transducers 3 and 4 are any suitable interdigital transducer used in SAW devices. The wave transmitting layer 5, a porous piezoelectric layer, is fabricated onto the substrate 1 such that the transducers 3 and 4 lie between the substrate 1 and the layer 5.

A sensing layer 6 is deposited on to the wave propagation layer 5 to form a surface which is physically, chemically or biologically active, selectively to agents in the liquid or gaseous media to which the surface 6 is exposed.

Figure 2 is a cross sectional view of another embodiment similar to that of figure 1 except that a transitional layer 9 and a protecting layer 10 are also included. The transitional layer 9 is preferably an acoustically sensitive layer such as SiO_2 which increases the velocity shift and as a result increases the electromechanical coupling factor. The transition layer 9 lies between the wave transmitting layer 5 and the substrate 1 so that the distance between the first IDT and layer 5 is increased to facilitate a higher coupling coefficient and reduce the acoustic wave transmission energy loss which otherwise occur. The protective layer 10 lies between the sensing layer 6 and the piezo layer 5 to protect layer 5 from damage. The protective layer 10 may also be SiO_2 .

In figure 3 a second wave generating transducer 7 and a second receiving transducer 8 above the substrate layer and below the wave transmitting layer and near the first generating transducers 3 and receiving transducers 4. Both sets of transducers may be located on substrate 1 or the second set may be on a separate substrate. It is preferred that no sensing layer is located above the second set of transducers 7 and 8 so that they can function as a reference sensor.

In figure 4 the SAW device of this invention is shown in a detector device. A frequency counter 11 determines frequency of the output signals and a computing device 12 calculates the concentration of the detectable components in the liquid or gaseous media. The output from the first receiver transducer 4 contains the sensing signal which is a consequence of the interaction between the sensing layer and the target molecules. The output from the second receiving transducer 8 contains only the operational characteristics of the sensing device because there is no sensing layer 6 above it. This enables the analyser to compute accurately a signal indicative of the concentration of the target molecule.

The piezoelectric substrate must support SSBW mode of operation. A few examples of suitable piezoelectric materials are shown in table I.

Table 1. Some Piezoelectric Crystals Suited to Surface Skimming Bulk Wave (SSBW) Propagation

Piezoelectric	Euler angle ϕ	Euler angle θ	Euler angle ψ	SSBW Velocity (m/s)
90° rotated ST-Cut Quartz	0	132.75	90	4990
35.5° AT-cut quartz	0	125.15	90	5100
36° rotated YX-LiTaO ₃	0	36	0	4221
37° rotated LiNbO ₃	0	37.93	0	4802

- 5 The surface film must be a piezoelectric. A few examples piezoelectric films are shown in table 2.

Table 2 Piezoelectric films

Material	Most Common Deposition methods *	Structure **
CdS	VE	PC
ZnO	CVD, RF-MSP	SC, PC
Bi12PbO19	RF-SP	PC
AlN	RF-SP, CVD	SC/PC

- 10 *) VE (Vacuum Evaporation), CVD (Chemical Vapour Deposition), (Radio Frequency Magnetron Sputtering), RF-SP (Radio Frequency Sputtering)
 **) PC (Poly crystal), SC (Single Crystal)

Example 1

- 15 A dual line ZnO/ 90° rotated ST-Cut Quartz crystal structure is fabricated with a ZnO layer ranging from 0 to 3.2 microns. A 15 nm Cr(5nm) /Au(12nm) layer is deposited as the sensitive layer over one of the delay lines. Cr/Au grows along the ZnO cylinders which increases the sensing surface of the gold.
- Coupling coefficient, temperature coefficient velocity, insertion loss have been
 20 studied as a function of layer thickness. Magnitudes have been compared with SiO₂ /90° rotated ST-cut quartz crystal structure.
- The love wave transducers are fabricated on 0.5mm thick 90° rotated ST-cut quartz crystal wafers. The transmit and receive IDT's consisted of 64 and 16 finger pairs in input and output ports respectively. The utilised acoustic
 25 wavelength is 50microns. The acoustic centre to centre distance of transmitting

and receiving IDT's is 60 wavelengths and aperture was chosen as 50 wavelengths.

ZnO films of different thicknesses were deposited by a r.f. magnetron sputterer. ZnO is a piezoelectric material of hexagonal crystalline structure. It is a wurtzite type crystal with a 6mm symmetry. Layers occupied by zinc atoms alternate with
5 layers occupied by oxygen atoms. The effective ionic charges are about 1 to 1.2 which results in polar c axis.

The epitaxial growth of ZnO films is influenced by deposition rate, substrate temperature, sputtering gas pressure and target configuration.

10 Table 3 illustrates the conditions of epitaxial ZnO film on ST-cut quartz crystal wafers.

Table 3

Target substrate distance	5cm
Sputtering gas combination	Ar 60% + O ₂ 40%
Sputtering gas Pressure	0.01 torr
Substrate temperature	270°C
RF power	40 W
Deposition rate	0.64 micron/h

The film deposited at 270 °C showed a resistivity as high as 5×10^6 ohm/cm.

15 Electro mechanical coupling coefficients for ZnO and SiO₂ films on ST-cut quartz wafers are shown in figure 5.

Example 2

An example of the response of the system to a sequence of different solutions is
20 shown in Fig. 6.

The sensitive layer is gold. A flow of IgG (Immuno-Globulin G, 100ng/ml) and BSA (Bovine Serum Albumin, 0.01mg/ml) in 7.4 pH buffer pumped into the liquid cell with a flow rate of 0.05 ml/minute.

25 With the purge of IgG solution in buffer, IgG particles are adsorb to Au surface. It causes a frequency shift of about 4 KHz. Then the flow of buffer continues till all IgG dissociate from the surface. Afterwards, BSA is used to cover the Au surface and the surface of the reference transducer. By covering the sensitive layer there

will be no adsorption and response occurs with another flow of IgG solution. Afterwards, Au surface was cleaned with a purge of Sodium Acetate solution. Then IgG solution liquid would be pumped and there will be the same frequency shift due to the adsorption of IgG particles on the Au surface. It shows the experiment is repeatable and only responds to the selective layer.

Other methods that can be used for protein immobilization are:

- 1- The physical adsorption onto the selective layer
- 2- Covalent binding to the selective layer
- 3- Adsorption into polymeric selective layers
- 4- Inclusion in a polymer lattice
- 5- Inclusion by sheeting with a membrane
- 6- Cross-linking a co-polymerization with either di-functional or poly-functional chemical reactive monomers

15 **Example 3**

For gas sensing experiments, the thickness of the ZnO layer was 2.8 μm giving an operational frequency of 90 MHz for the periodicity of 50 μm . The sensor was heated to 350°C by a micro-heater located beneath the device.

The sensor was exposed to different concentrations of oxygen in nitrogen gas to investigate the response the Love mode SAW sensor. The response to 100 ppm of oxygen in nitrogen is shown in Fig. 7. Exposing the device to oxygen gas increases the operational frequency of the system. This increase in frequency is almost +18 kHz. For oxygen, the response and recovery times are continuous which stand for a single reaction on the surface.

The response of the sensor to different oxygen concentrations is shown in Fig. 8. The response of the sensor to 50 ppm is equal to -11 kHz. If the response from this point onward would continue to be linear, then the response of the device to 0.5 ppm will be equal to 110 Hz. The noise of the system is approximately 50 Hz in the gas media.

From the above it can be seen that this invention provides a unique sensor structure with significant advantages. Those skilled in the art of biological sensing will realise that the sensor of this invention can be adapted to detect a wide variety of biological or chemical moieties in both liquid and gaseous media.

Claims

1. A surface acoustic wave sensor in which a layer of a piezoelectric material lies on the surface of a piezoelectric substrate.
- 5 2. A surface acoustic wave liquid media sensor in which a porous piezoelectric layer lies on a piezoelectric substrate cut for Love mode wave propagation
- 10 3. A sensor as claimed in claim 1 in which a layer of zinc oxide is deposited on 90° rotated ST-Cut Quartz crystal cut for propagating a love mode surface acoustic wave.
- 15 4. A sensor as claimed in claim 1 in which a biologically sensitive layer is deposited on the piezoelectric layer which is adapted to interact with an appropriate biochemical component to be detected.
- 20 5. A sensor for use in detecting chemical or biochemical moieties in gaseous or liquid mediums which incorporates a surface acoustic wave device which consisting of
 - a substrate of a piezoelectric quartz crystal
 - at least one interdigital transducer formed on said quartz crystal
 - a piezoelectric film of zinc oxide deposited on said crystal and transducer
 - 25 a biologically sensitive layer deposited on said zinc oxide layer
- 30 6. A sensor as claimed in claim 5 in which the biologically sensitive layer is gold.

1/5

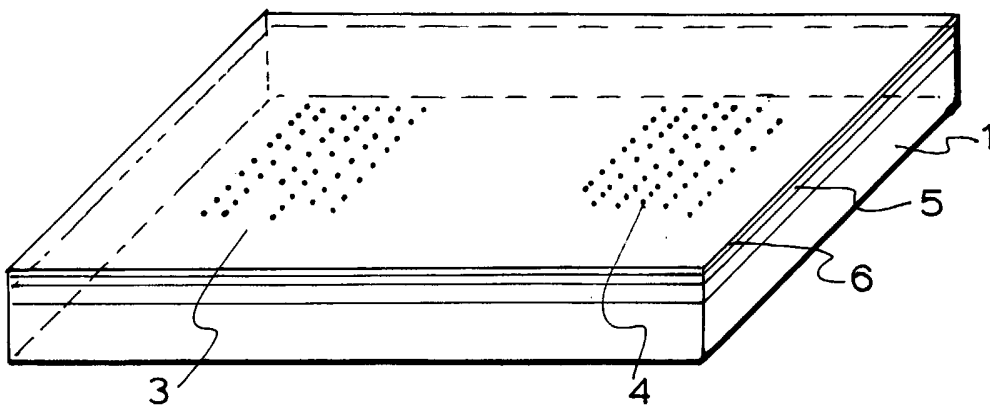

FIG.1.

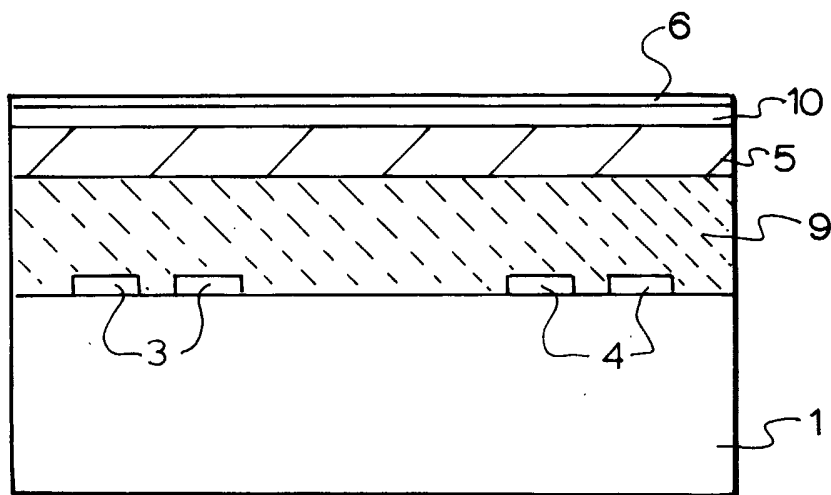

FIG.2.

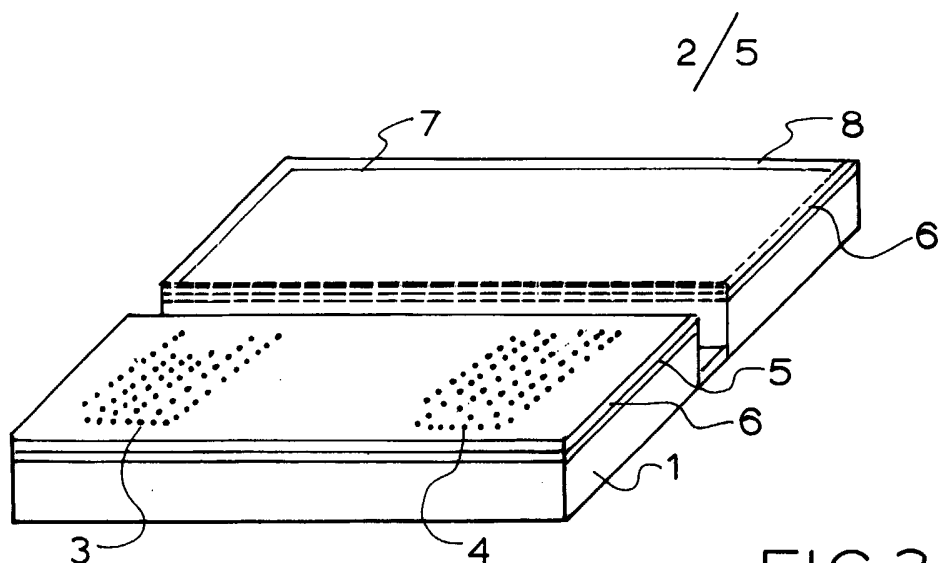

FIG. 3.

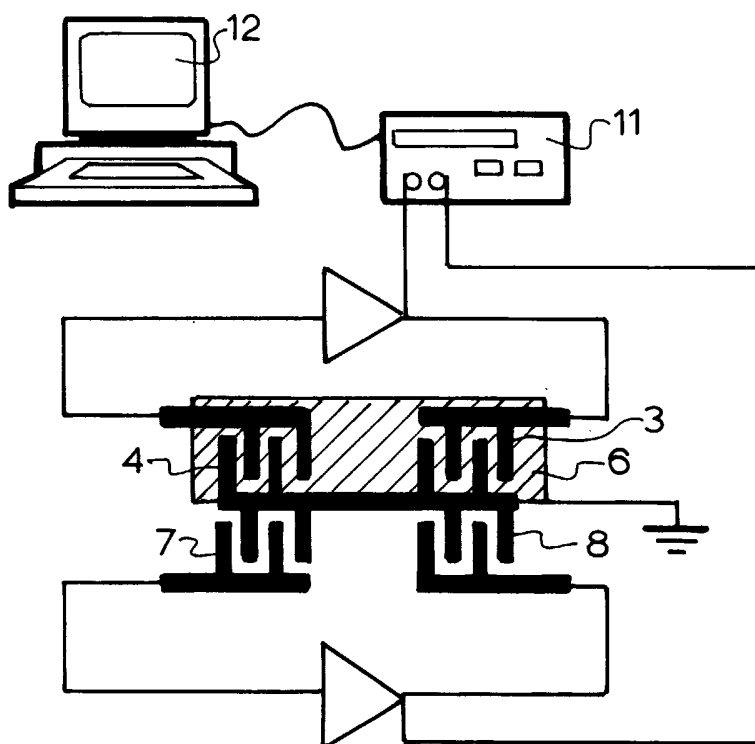

FIG. 4.

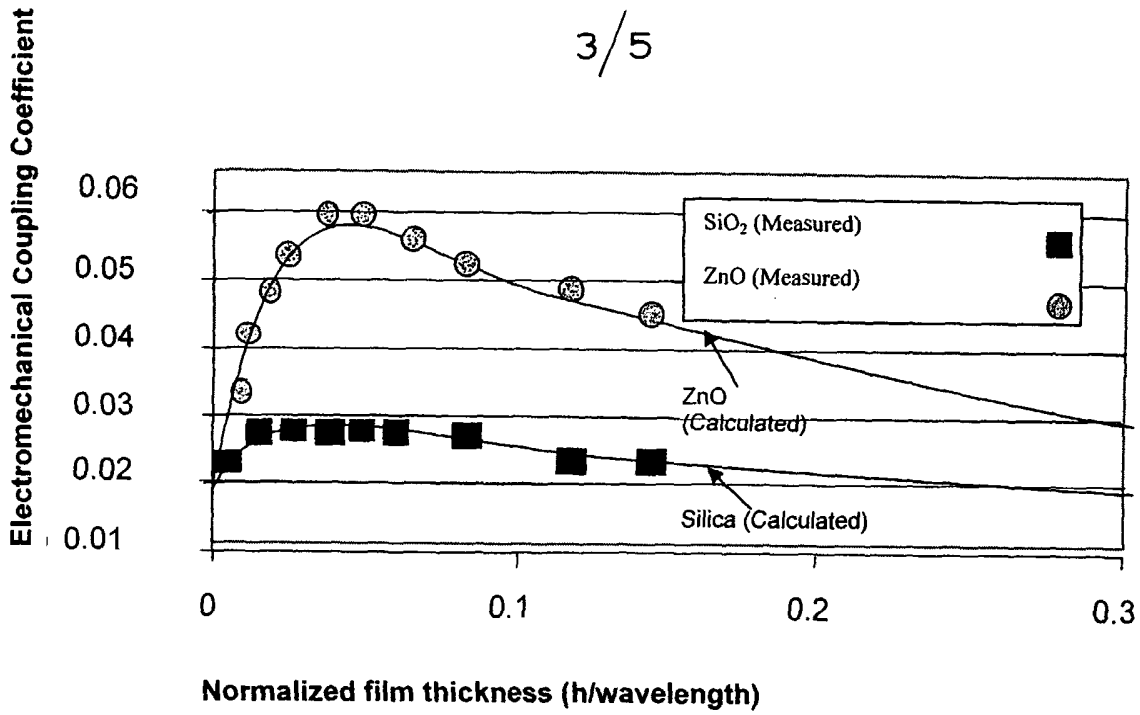

FIG. 5.

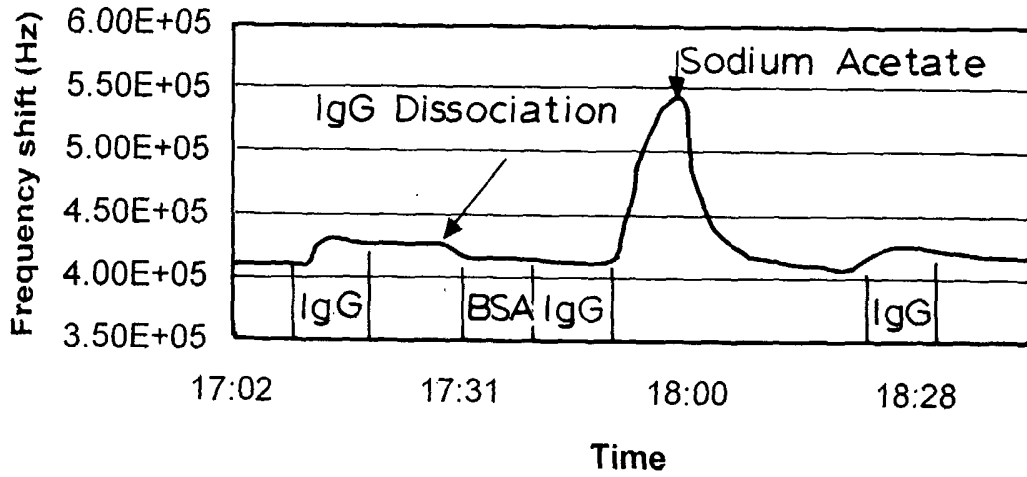

FIG. 6.

4 / 5

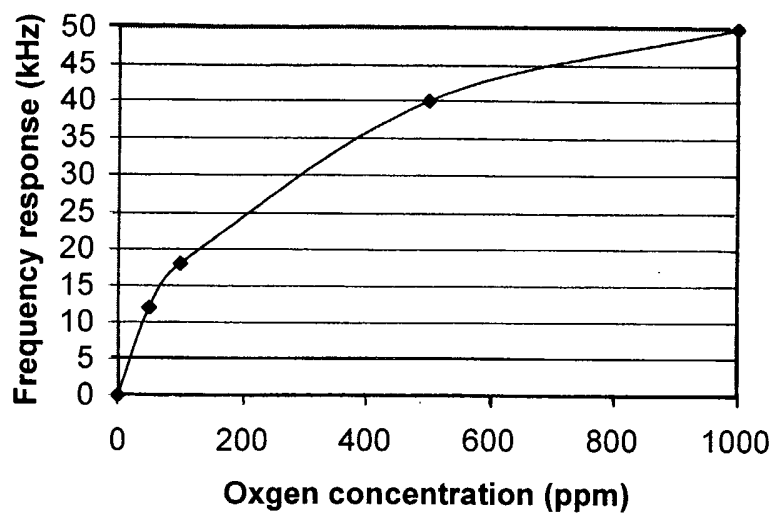

FIG. 7.

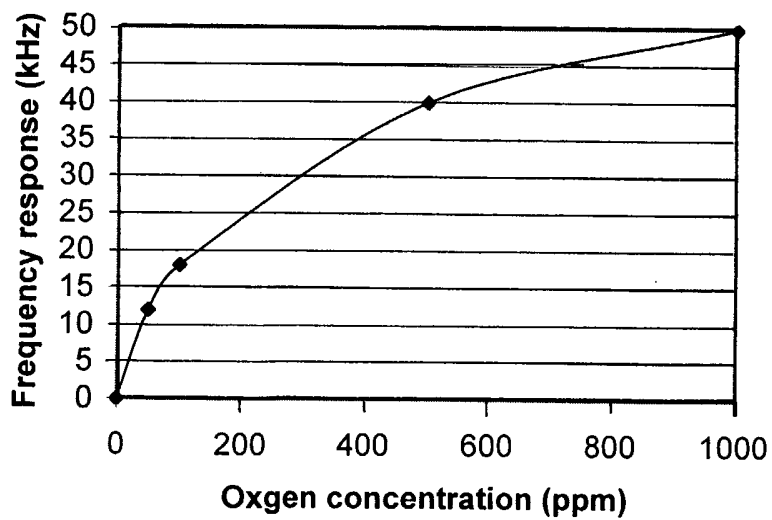

FIG. 8.

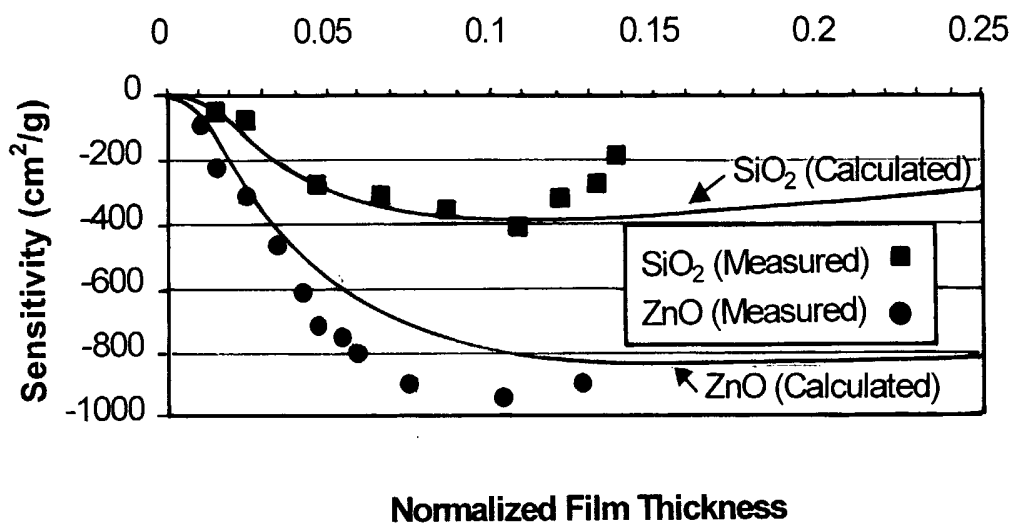
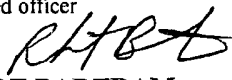

FIG. 9.

INTERNATIONAL SEARCH REPORT

International application No.

PCT/AU02/00616

A. CLASSIFICATION OF SUBJECT MATTER		
Int. Cl. ⁷ : H03H 9/25, 9/64		
According to International Patent Classification (IPC) or to both national classification and IPC		
B. FIELDS SEARCHED		
Minimum documentation searched (classification system followed by classification symbols)		
Documentation searched other than minimum documentation to the extent that such documents are included in the fields searched		
Electronic data base consulted during the international search (name of data base and, where practicable, search terms used)		
WPAT, USPTO, INTERNET - SAW, Surface acoustic wave, piezoelectric, Zinc, love		
C. DOCUMENTS CONSIDERED TO BE RELEVANT		
Category*	Citation of document, with indication, where appropriate, of the relevant passages	Relevant to claim No.
X Y	US 6121713 A (Inoue et al) 19 September 2000 Abstract, col. 1 ln. 20 - col. 3 ln. 53, col. 26 ln. 17 - col. 27 ln. 22, and figure 31	1 to 3 4 to 6
X	Patent abstracts of Japan, 11-136082 A (MATSUSHITA ELECTRIC INDUSTRIAL COMPANY LIMITED) 21 May 1999 See machine translation: [online], [retrieved on 2002-07-04]. Retrieved from the Internet: <URL:http://www1.ipdl.jpo.go.jp/PA1/cgi-bin/PA1DETAIL	1
X Y	Patent abstracts of Japan, 11-097973 A (MURATA MFG CO LTD) 9 April 1999 See machine translation: [online], [retrieved on 2002-07-04]. Retrieved from the Internet:<URL:http://www1.ipdl.jpo.go.jp/PA1/result/detail/main/wAAAa27019DA411097973P1.htm	1 and 2 3 to 6
<input checked="" type="checkbox"/> Further documents are listed in the continuation of Box C <input checked="" type="checkbox"/> See patent family annex		
* Special categories of cited documents:		
"A"	document defining the general state of the art which is not considered to be of particular relevance	"T" later document published after the international filing date or priority date and not in conflict with the application but cited to understand the principle or theory underlying the invention
"E"	earlier application or patent but published on or after the international filing date	"X" document of particular relevance; the claimed invention cannot be considered novel or cannot be considered to involve an inventive step when the document is taken alone
"L"	document which may throw doubts on priority claim(s) or which is cited to establish the publication date of another citation or other special reason (as specified)	"Y" document of particular relevance; the claimed invention cannot be considered to involve an inventive step when the document is combined with one or more other such documents, such combination being obvious to a person skilled in the art
"O"	document referring to an oral disclosure, use, exhibition or other means	"&" document member of the same patent family
"P"	document published prior to the international filing date but later than the priority date claimed	
Date of the actual completion of the international search 15 July 2002		Date of mailing of the international search report 23 JUL 2002
Name and mailing address of the ISA/AU AUSTRALIAN PATENT OFFICE PO BOX 200, WODEN ACT 2606, AUSTRALIA E-mail address: pct@ipaustalia.gov.au Facsimile No. (02) 6285 3929		Authorized officer  ROBERT BARTRAM Telephone No : (02) 6283 2215

INTERNATIONAL SEARCH REPORT

International application No.

PCT/AU02/00616

C (Continuation). DOCUMENTS CONSIDERED TO BE RELEVANT		
Category*	Citation of document, with indication, where appropriate, of the relevant passages	Relevant to claim No.
X Y	US 5847486 A (KADOTA et al) 8 December 1998 See whole document	1 and 2 3 to 6
X Y	US 5432392 A (KADOTA et al) 11 July 1995 See the whole document	1 and 2 3 to 6
Y	DRAFTS, Sensors, "Acoustic wave technology sensors", October 2000, Retrieved from the Internet on 19 June 2002: <URL:www.sensormag.com/articles/1000/68/main.stml	3 to 6
	Drafts and US 6121713 are combined with either of the Kadota documents or the Murata document	

This Annex lists the known "A" publication level patent family members relating to the patent documents cited in the above-mentioned international search report. The Australian Patent Office is in no way liable for these particulars which are merely given for the purpose of information.

Patent Document Cited in Search Report		Patent Family Member					
US	6121713	EP	869609	WO	9818204		
JP	11136082	NONE					
JP	11097973	NONE					
US	5847486	CN	1129372	JP	8125485	SG	38882
US	5432392	DE	4400980	JP	6268469	JP	7074586
		JP	7154192				
END OF ANNEX							

Box No. VIII (iv) DECLARATION: INVENTORSHIP (only for the purposes of the designation of the United States of America)
The declaration must conform to the following standardized wording provided for in Section 214; see Notes to Boxes Nos. VIII, VIII (i) to (v) (in general) and the specific Notes to Box No. VIII (iv). If this Box is not used, this sheet should not be included in the request.

Declaration of inventorship (Rules 4.17(iv) and 51bis.1(a)(iv)) for the purposes of the designation of the United States of America:

I hereby declare that I believe I am the original, first and sole (if only one inventor is listed below) or joint (if more than one inventor is listed below) inventor of the subject matter which is claimed and for which a patent is sought.

This declaration is directed to the international application of which it forms a part (if filing declaration with application).

This declaration is directed to international application No. PCT/..... (if furnishing declaration pursuant to Rule 26ter).

I hereby declare that my residence, mailing address, and citizenship are as stated next to my name.

I hereby state that I have reviewed and understand the contents of the above-identified international application, including the claims of said application. I have identified in the request of said application, in compliance with PCT Rule 4.10, any claim to foreign priority, and I have identified below, under the heading "Prior Applications," by application number, country or Member of the World Trade Organization, day, month and year of filing, any application for a patent or inventor's certificate filed in a country other than the United States of America, including any PCT international application designating at least one country other than the United States of America, having a filing date before that of the application on which foreign priority is claimed.

Prior Applications:

I hereby acknowledge the duty to disclose information that is known by me to be material to patentability as defined by 37 C.F.R. § 1.56, including for continuation-in-part applications, material information which became available between the filing date of the prior application and the PCT international filing date of the continuation-in-part application.

I hereby declare that all statements made herein of my own knowledge are true and that all statements made on information and belief are believed to be true; and further that these statements were made with the knowledge that willful false statements and the like so made are punishable by fine or imprisonment, or both, under Section 1001 of Title 18 of the United States Code and that such willful false statements may jeopardize the validity of the application or any patent issued thereon.

Name: Kourosh Kalantar-Zadeh

Residence: Melbourne Australia (city and either US state, if applicable, or country)

Mailing Address: School of Electrical & Computer Engineering, RMIT, 124 Latrobe Street, Melbourne, Victoria, 3000, Australia

Citizenship: Australian

Inventor's Signature: [Handwritten Signature] Date: 30/04/02 (if not contained in the request, or if declaration is corrected or added under Rule 26ter after the filing of the international application. The signature must be that of the inventor, not that of the agent)

Name: Wojtek Wlodarski

Residence: Melbourne Australia (city and either US state, if applicable, or country)

Mailing Address: School of Electrical & Computer Engineering, RMIT, 124 Latrobe Street, Melbourne, Victoria, 3000, Australia

Citizenship: Australian

Inventor's Signature: [Handwritten Signature] Date: 30/04/02 (if not contained in the request, or if declaration is corrected or added under Rule 26ter after the filing of the international application. The signature must be that of the inventor, not that of the agent)

[] This declaration is continued on the following sheet, "Continuation of Box No. VIII (iv)".