

S. H. Gilman,
Reciprocating Steam Engine,
N^o 7,830, *Patented Dec. 10, 1850.*

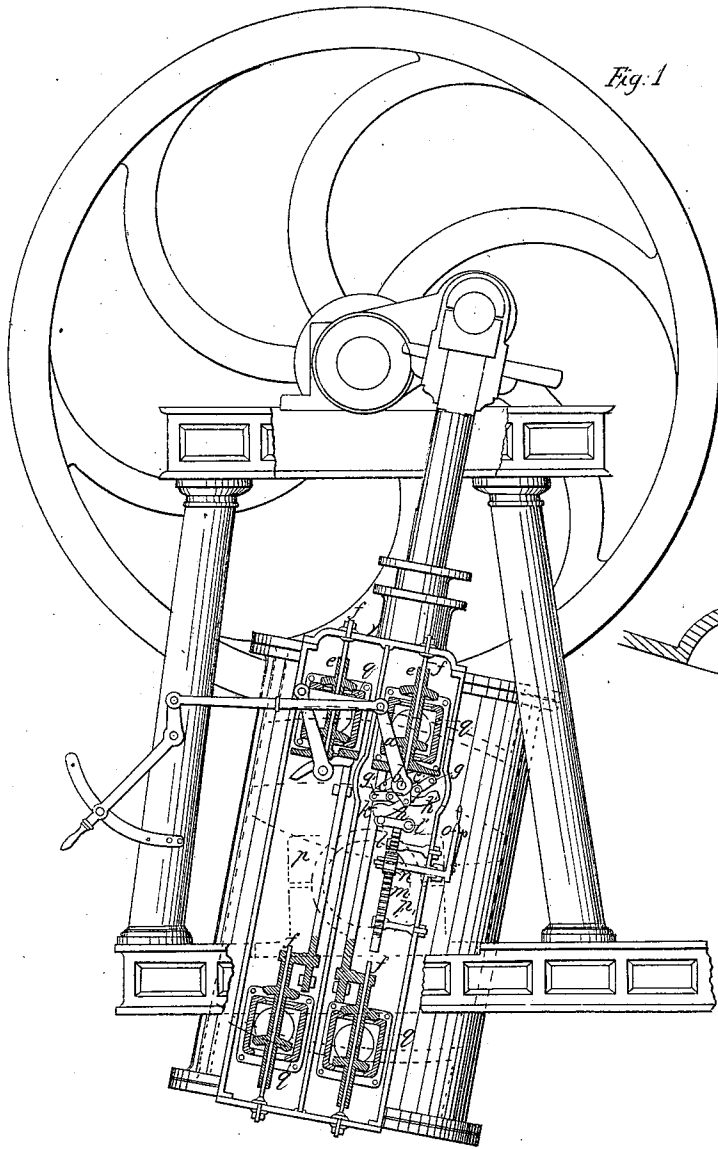

Fig. 1

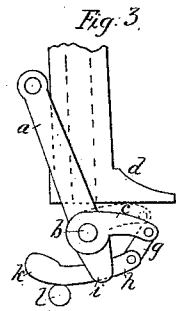

Fig. 3

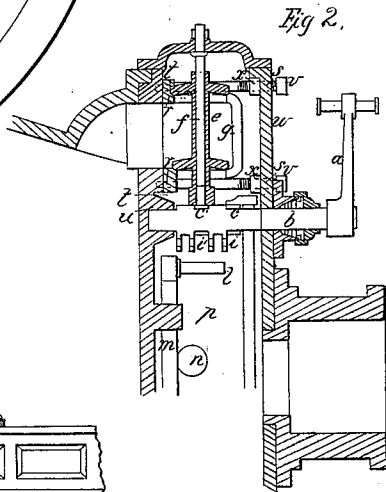

Fig. 2

UNITED STATES PATENT OFFICE.

SAML. H. GILMAN, OF CINCINNATI, OHIO.

CUT-OFF MOTION FOR PUPPET-VALVES.

Specification of Letters Patent No. 7,830, dated December 10, 1850.

To all whom it may concern:

Be it known that I, SAMUEL H. GILMAN, of Cincinnati, Hamilton county, Ohio, have invented new and useful Improvements in Valve-Gearing of Steam-Engines; and I do hereby declare the following to be a full, clear, and exact description of the nature, construction, and operation of the same, reference being had to the annexed drawings, making part of this specification.

Figure 1 in the said drawings is a view of the working parts within the steam chamber or chest, the valves with their guide, seats and movable chambers being drawn in section, more clearly to show their construction. Fig. 2 is a vertical section through the axis of the rock shaft. Fig. 3 is an enlarged view of cut off movement in its tripped position.

The same or similar parts are indicated by like letters in the several figures.

The nature of my invention consists in a provision for cutting off at any desired point the supply of steam to the cylinder when drop valves are used, by making the lifters vibratable upon the rock shaft and causing them to act in obedience to the motions of gravitating toggles which being tripped by impact with an adjustable stop, allow the lifter to rotate upon the shaft and the valve to descend.

This invention is shown as applied to the supply valves of an oscillating engine, the steam chest of which is upon the trunnion side, the trunnion making part of the supply passage and being cast in one piece with the front of the steam chest.

The arrangement of the chest as seen in the drawing has a twofold object, namely to give the rock shaft which lifts the supply valves as nearly equal action in both halves of its sweep as is consistent with the attachment of the trunnion and a due approximation to equipoise of the cylinder upon the axis of its vibration.

The parts represented in the drawing and not lettered, need no particular description, as they merely constitute what is usual in oscillating engines. I shall therefore only refer to by letter and describe the parts involved in the invention.

(a) is an arm, attached to and vibrating with the rock shaft (b).

(c) is the lifter of the upper valve and (c') is the lifter of the lower valve; both lifters have free play upon the rock shaft (b).

(d) is the foot of valve stem (e).

All the valve stems are hollow for the reception of guide rods (f) which are attached at one end of the cap of the valve chest, and supersedes entirely the necessity of any bridges or other obstructions athwart the valve opening.

The free extremity of each lifter is jointed to the link (g or g') of a toggle which is completed by the said link being jointed to another link (h or h') which is in its turn jointed to an arm (i or i') projecting down from and vibrating with the rock shaft, the second link (h) of the toggle extending down beyond the joint sufficiently far, for the purpose, when allowed to gravitate, of counterbalancing and fixing the lifter for operating the valve, and also for the purpose of letting the valves drop gently down to its seat, when by the motion of the rock shaft, the projection (k) by impact with the pin (l) is tripped upward. The upper member of the link (h) is by the superior gravity of the loaded end (k) caused to press against the rock shaft (b) and thus affords through the link (g) a fixed point of support for the lifter (c) so that it may be able to lift the valve, but when the projection (k) is lifted by contact with the adjustable stop—the knuckle of the toggle is instantly bent in the opposite direction, and the lifter consequently depressed so as gently to drop and ease down the supply valve upon its seat.

The adjustable stop is operated as seen by a rack (m) and pinion (n) within the steam chest, an index arm (o) being fixed upon the shaft of the pinion without side the steam chest (p).

Having thus fully, clearly, and exactly described the nature and construction of my invention, what I claim therein as new and desire to secure by Letters Patent is—

Raising and dropping at any desired point the puppet valves that admit steam to the cylinders by means of a lifter that vibrates, with and upon the usual rock shaft, the said lifter being operated by a gravitating and counterbalancing toggle as described so that

the lifter in the manner described or its
equivalent is fixed for raising the valve and
is depressed and allowed gradually and
easily to drop the valve when the counter-
5 balance of the toggle is operated by the ad-
justable stop, substantially as herein de-
scribed.

In testimony whereof, I have hereunto set
my hand before two subscribing witnesses.

SAMUEL H. GILMAN.

Witnesses:

EDWARD H. KNIGHT,
THOS. G. CLINTON.