

CATHETER PUMP

INCORPORATION BY REFERENCE TO ANY PRIORITY APPLICATIONS

[0001] Any and all applications for which a foreign or domestic priority claim is identified in the Application Data Sheet as filed with the present application, including US Application No. 61/667,903 filed July 3, 2012 entitled *Catheter Pump*, are hereby incorporated by reference under 37 CFR 1.57.

BACKGROUND OF THE INVENTION

Field of the Invention

[0002] This application is directed to a catheter pump for mechanical circulatory support of a heart.

Description of the Related Art

[0003] Heart disease is a major health problem that has high mortality rate. After a heart attack, only a small number of patients can be treated with medicines or other non-invasive treatment. However, a significant number of patients can recover from a heart attack or cardiogenic shock if provided with mechanical circulatory support.

[0004] In a conventional approach, a blood pump having a fixed cross-section is surgically inserted between the left ventricle and the aortic arch to assist the pumping function of the heart. Other known applications involve providing for pumping venous blood from the right ventricle to the pulmonary artery for support of the right side of the heart. The object of the surgically inserted pump is to reduce the load on the heart muscle for a period of time, to stabilize the patient prior to heart transplant or for continuing support. Surgical insertion, however, can cause additional serious stresses in heart failure patients.

[0005] Percutaneous insertion of a left ventricular assist device ("LVAD"), a right ventricular assist device ("RVAD") or in some cases a system for both sides of the heart (sometimes called biVAD) therefore is desired. Conventional fixed cross-section ventricular assist devices designed to provide near full heart flow rate are too large to be advanced percutaneously, e.g., through the femoral artery.

[0006] There is a continuing need for improved cannula that provide sufficient expansion force and a stable expanded shape while still allowing for reliable and easy

collapse to a delivery size. In other words, the cannula should have sufficient force to expand, but also be collapsible under significant sheathing force while avoiding a risk of damaging the cannula during re-sheathing. There is a continuing need for improved cannula that can be expanded and collapsed, in some cases over many cycles, without risking breakage of the struts and connectors forming the mesh. Broken struts pose a risk of complicating patient treatment and/or compromising the performance of the device.

SUMMARY OF THE INVENTION

[0007] There is an urgent need for a pumping device that can be inserted percutaneously and also provide full cardiac rate flows of the left, right, or both the left and right sides of the heart when called for.

[0008] In one embodiment, an apparatus is provided for inducing motion of a fluid relative to the apparatus. The apparatus can be a catheter pump, as discussed below. The apparatus can include a rotatable impeller and an elongate cannula. The cannula has a plurality of circumferential members and a plurality of circumferential connectors. The circumferential members are disposed about a space, e.g., a volume including at least the impeller zone. One or more of, e.g., each of, the circumferential members can have an undulating configuration including a plurality of apices connected by elongate struts. The circumferential connectors can be disposed between alternating struts of adjacent circumferential members. A plurality of axial connectors is disposed between a proximal side of a proximal apex and a distal side of an adjacent circumferential member in the impeller zone of cannula.

[0009] In some embodiments, the cannula is differentiated along its length to have varying stiffness. The elongate cannula has an impeller zone disposed about the impeller and a distal zone disposed distal of the impeller zone. The distal zone can be made more flexible by reducing the number of connectors disposed therein. For example, the impeller zone can have alternating elongate struts that are connected by circumferential connectors and the distal zone can have alternating elongate struts that are free of such connections.

[0010] In one variation, each of the connectors of the plurality has a distal end coupled with a proximal side of a proximal apex of a first circumferential member, a proximal end coupled with a distal face of a second circumferential member disposed

adjacent to and proximal of the first circumferential member. Each of the connectors has an arcuate section disposed between the proximal and distal ends. In this variation, the arcuate section comprises a single convex portion disposed between the proximal and distal ends.

[0011] A first plurality of axial connectors is disposed between a proximal side of a proximal apex and a distal side of an adjacent circumferential member in the impeller zone of the cannula. A second plurality of axial connectors is disposed between a proximal side of a proximal apex and a distal side of an adjacent circumferential member in the distal zone of the cannula.

[0012] In another embodiment, an apparatus for pumping blood includes a rotatable impeller, an elongate cannula, and a sheath configured to be positioned over the elongate cannula. The elongate cannula has a plurality of circumferential members disposed about the impeller. One or more of, e.g., each of, the circumferential members can have an undulating configuration. The undulating configuration can include a plurality of proximal and distal apices, with proximal apices connected to distal apices by an elongate strut. The sheath is configured to be positioned over the elongate cannula to actuate the cannula from an expanded configuration to a collapsed configuration. The elongate cannula is configured to deflect radially inwardly in an area around the proximal apices before the apices move into the sheath.

[0013] In some configurations, the elongate cannula has an impeller zone disposed about the impeller and a distal zone disposed distal of the impeller zone. For example, the impeller can extend in about one-half or less of the length of the cannula. The distal zone may be more easily compressed by the sheath because the impeller is not present in that area. As a result, the cannula can have a different configuration in the distal zone.

[0014] In another configuration, a catheter pump is provided. A catheter pump is an example of an apparatus for inducing motion of a fluid relative to the apparatus. The catheter pump includes a rotatable impeller and an elongate cannula having a mesh comprising a plurality of circumferential members disposed about the impeller. The mesh also has a plurality of axial connectors extending between a proximal side of a distal circumferential member and a distal side of a proximal circumferential member. The circumferential members are radially self-expandable. A sheath is configured to be positioned over the elongated cannula to actuate the cannula from an expanded configuration

to a collapsed configuration. The cannula is configured to minimize a risk of fracture within the mesh, e.g., of the axial connectors, as the elongated cannula moves into the sheath.

[0015] In a further embodiment, an apparatus for inducing motion of a fluid relative to the apparatus is provided. The apparatus includes a rotatable impeller and an elongate cannula. The elongate cannula defines a blood flow channel in which the impeller is disposed. The cannula has an expandable structure comprising that has a plurality of circumferential members, a plurality of circumferential connectors, and a plurality of axial connectors. The circumferential members are disposed about the blood flow channel. The circumferential members have an undulating configuration including a plurality of apices connected by elongate struts. The circumferential connectors are disposed between alternating struts of adjacent circumferential members. The axial connectors have a distal end coupled with a proximal side of a proximal apex of a first circumferential member, a proximal end coupled with a distal face (e.g., an edge) of a second circumferential member disposed adjacent to and proximal of the first circumferential member. The axial connectors have an arcuate section disposed between the proximal and distal ends. The arcuate section comprises a single convex portion disposed between the proximal and distal ends.

[0016] In another embodiment, an apparatus for pumping blood is provided that includes a rotatable impeller, an elongate cannula, and an axial member. The elongate cannula has a plurality of circumferential members disposed about the impeller. One or more of the circumferential members has an undulating configuration including a plurality of proximal and distal apices. Each proximal apex is connected to a distal apex by an elongate strut. The axial member has a distal end coupled with a proximal apex of a first circumferential member a proximal end coupled with a second circumferential member disposed proximal of the first circumferential member. The axial member has a length that is less than the distance between the proximal apex to which the distal end of the axial member is connected and a proximal apex of the second circumferential member that is axially aligned with the proximal apex to which the distal end of the axial member is connected.

[0017] In another embodiment, a catheter pump is provided that includes a rotatable impeller and an elongate cannula. The elongate cannula has a mesh that has a plurality of circumferential members disposed about the impeller. The elongate cannula has a plurality of axial connector extending between a proximal side of a distal circumferential

member and a distal side of a proximal circumferential member. The circumferential members are radially self-expandable. The cannula is configured to minimize fracture within at least in the distal zone of the mesh as the elongated cannula moves into a sheathing device.

[0018] In another embodiment, a cannula for conveying blood is provided that includes an in-situ expandable and collapsible mesh structure and a polymeric enclosure. The in-situ expandable and collapsible mesh structure has a plurality of undulating circumferential members surrounding a lumen. Each circumferential member has proximal and distal vertices. The polymeric enclosure is disposed about the mesh structure to enclose the lumen along a length between an inlet and an outlet. The number of proximal vertices in an area defined between a proximal circumference intersecting the proximal vertex of a circumferential member and a distal circumference intersecting the distal vertex of the same circumferential member adjacent to the proximal vertex is at least two.

BRIEF DESCRIPTION OF THE DRAWINGS

[0019] A more complete appreciation of the subject matter of this application and the various advantages thereof can be realized by reference to the following detailed description, in which reference is made to the accompanying drawings in which:

[0020] Figure 1 illustrates one embodiment of a catheter pump configured for percutaneous application and operation;

[0021] Figure 2 is a plan view of one embodiment of a catheter assembly adapted to be used with the catheter pump of Figure 1;

[0022] Figure 3 show a distal portion of the catheter assembly of similar to that of Figure 2 in position within the anatomy;

[0023] Figure 4 illustrates a wall pattern of a mesh structure in a flat configuration, where the mesh structure is configured to provide enhanced flexibility in a distal zone;

[0024] Figure 4A is a detail view of a distal portion of the wall pattern of Figure 4;

[0025] Figure 5 shows a formed mesh structure for a cannula having a wall pattern similar to that of Figure 4;

[0026] Figure 5A is a detail view of the distal portion of the formed mesh structure of Figure 5;

[0027] Figure 6 illustrates another wall pattern of a mesh structure in a flat configuration, where the mesh structure is configured to minimize fracture risk;

[0028] Figure 6A is a detail view of a distal portion of the wall pattern of Figure 6;

[0029] Figure 7 shows a cannula including a formed mesh structure having the wall pattern similar to that of Figure 6 covered with a film layer;

[0030] Figure 7A is a detail view of a distal portion of the cannula of Figure 7;

[0031] Figure 8 illustrates another wall pattern of a mesh structure in a flat configuration, where the mesh structure is configured to provide enhanced flexibility in a distal zone, while minimizing fracture risk;

[0032] Figure 9 shows a formed mesh structure for a cannula having the wall pattern of Figure 8;

[0033] Figure 10 illustrates another wall pattern of a mesh structure in a flat configuration, where the mesh structure is configured to provide enhanced flexibility in a distal zone, while minimizing fracture risk;

[0034] Figure 11 shows a formed mesh structure for a cannula having the wall pattern of Figure 10;

[0035] Figure 12 is a detail view of a distal portion of the wall pattern of Figure 8 and 10;

[0036] Figure 13 is a detail view of a first variation of the distal portion of the formed mesh structure of Figure 12;

[0037] Figure 14 is a detail view of a second variation of the distal portion of the formed mesh structure of Figure 12;

[0038] Figure 14A-1 is a detail view of a proximal portion of another variation of a wall pattern that is stable and minimizes fracture;

[0039] Figure 14A-2 is a detail view of a central portion of the wall pattern for which the proximal portion is shown in Figure 14A-1

[0040] Figure 14A-3 is a detail view of a distal portion of the wall pattern for which the proximal portion is shown in Figure 14A-1

[0041] Figure 15 illustrates another wall pattern of a mesh structure in a flat configuration, where the mesh structure is configured to provide more ports for blood to flow into or out of a cannula formed with this pattern;

[0042] Figure 15A is a detail view of a proximal portion of the pattern of Figure 15;

[0043] Figure 16 is an expanded view of the pattern of Figures 15-15A; and

[0044] Figure 17 is a graph of the sheathing force for collapsing a cannula and an impeller for an example wall pattern.

[0045] More detailed descriptions of various embodiments of components for heart pumps useful to treat patients experiencing cardiac stress, including acute heart failure, are set forth below.

DETAILED DESCRIPTION OF THE PREFERRED EMBODIMENT

[0046] This application is directed to apparatuses for inducing motion of a fluid relative to the apparatus. The apparatus can be a catheter pump, e.g., a percutaneous heart pump.

[0047] Figures 1 and 2 illustrate various features of a catheter pump 10. The catheter pump 10 can provide high performance including flow rates similar to full cardiac output. The pump 10 includes a motor driven by a controller 22. The controller 22 directs the operation of the motor 14 and an infusion system 26 that supplies a flow of infusate in the pump 10. A catheter system 80 that can be coupled with the motor 14 houses an impeller within a distal portion thereof. In various embodiments, the impeller is rotated remotely by the motor 14 when the pump 10 is operating. For example, the motor 14 can be disposed outside the patient. In some embodiments, the motor 14 is separate from the controller 22, e.g., to be placed closer to the patient. In other embodiments, the motor 14 is part of the controller 22. In still other embodiments, the motor is miniaturized to be insertable into the patient. Such embodiments allow the drive shaft to be much shorter, e.g., shorter than the distance from the aortic valve to the aortic arch (about 5 cm or less). Some examples of miniaturized motors catheter pumps and related components and methods are discussed in US5,964,694; US6,007,478; US6,178,922; and US 6,176,848, all of which are hereby incorporated by reference herein in their entirety for all purposes.

[0048] Figure 3 illustrates one use of the catheter pump 10. A distal portion of the pump 10 is placed in the left ventricle LV of the heart to pump blood from the LV into the aorta. The pump 10 can be used in this way to treat patients with a wide range of conditions, including cardiogenic shock, myocardial infarction, and acutely decompensated heart failure, and also to support a patient during a procedure such as percutaneous coronary intervention. One convenient manner of placement of the distal portion of the pump 10 in the heart is by percutaneous access and delivery using the Seldinger technique or other methods familiar to cardiologists. These approaches enable the pump 10 to be used in emergency medicine, a catheter lab and in other non-surgical settings. Modifications can also enable the pump 10 to support the right side of the heart. Example modifications that could be used for right side support include providing delivery features and/or shaping a distal portion that is to be placed through at least one heart valve from the venous side, such as is discussed in US6,544,216; US 7,070,555; and US 2012-0203056A1, all of which are hereby incorporated by reference herein in their entirety for all purposes.

[0049] Figure 2 shows features that facilitate small blood vessel percutaneous delivery and high performance up to and in some cases exceeding normal cardiac output in all phases of the cardiac cycle. In particular, the catheter system 80 includes a catheter body 84 and a sheath assembly 88. An impeller assembly 92 is coupled with the distal end of the catheter body 84. The impeller assembly 92 is expandable and collapsible. In the collapsed state, the distal end of the catheter system 80 can be advanced to the heart. In the expanded state the impeller assembly 92 is able to pump blood at relatively high flow rates. Figures 2 and 3 illustrate the expanded state. The collapsed state can be provided by advancing a distal end 94 of an elongate body 96 distally over the impeller assembly 92 to cause the impeller assembly 92 to collapse. This provides an outer profile throughout the catheter assembly 80 that is of small diameter, for example 12.5 French as discussed further below.

[0050] Embodiments of the catheter pumps of this application can be configured with expandable structures to enhance performance. For example, an impeller for moving blood axially can be provided. The impeller can be positioned in an expandable cannula. When so positioned, the expandable cannula provides dual function of enclosing a blood flow lumen through which the impeller can act and also housing the impeller. In that sense, the cannula is also an expandable housing. The expandable cannula and impeller provide a

flow rate in the pump that is much larger than would be possible using percutaneous access techniques were these components not capable of expanding. However, it may be possible to reduce flow resistance by increasing the size of a blood-flow cannula even with a fixed diameter impeller. Also, it may be possible to sequentially collapse the impeller, e.g., by withdrawing the impeller into a rigid ring or tubular segment prior to collapsing the impeller. These variant also benefit from many of the embodiments herein and are within the scope of this application even though the impeller may not be housed in the cannula at all times or at all.

[0051] While these configurations provide excellent flow rates, a challenge arises in collapsing the expanded structures prior to removal from the patient. The collapsing of the impeller assembly 92 in this manner is not straight-forward. In various embodiments, a mesh is used to support the expandable portion of a blood flow conduit in the impeller assembly 92. The expandable portion can include a self-expanding structure that expands when undulating generally ring-shaped members release stored strain energy arising from circumferential compression. Compression of such a structure involves transforming axial relative movement of the sheath assembly 88 over the catheter body 84 into a circumferential compression force. There is a chance that such movement will cause the distal end to become lodged between adjacent undulating members. Such problems with compression can be more likely to occur when the undulating members are spaced apart by an axial distance that is greater than the wall thickness of the distal end of the sheath assembly 88. While the undulating members could be moved much closer together, such an approach could make the expandable structure too stiff thereby inhibiting collapse of the expandable portion. Some embodiments herein are configured to reduce this risk, while retaining sufficient flexibility. Some embodiments are configured to prevent connectors between adjacent rings from being deformed around the distal end of the sheath assembly 88. Various aspects of the expandable cannula and/or mesh in accordance with the invention achieve a careful balance of expansion force, collapsing force, and structural strength. Figures 4-16 illustrate various embodiments of mesh structures that can be incorporated into the expandable cannula to provide advantageous performance in use.

[0052] Additional details of the structures disclosed in these figures, and various modified embodiments thereof, and method related to the same are discussed in US

Application No. 13/343,617, filed January 4, 2012, which is hereby incorporated by reference herein in its entirety. In addition, this application incorporates by reference in its entirety and for all purposes the subject matter disclosed in each of the following concurrently filed applications: United States Patent Application No. 13/802,556, which corresponds to attorney docket no. THOR.072A, entitled "DISTAL BEARING SUPPORT," filed on March 13, 2013; United States Patent Application No. 61/780,656, which corresponds to attorney docket no. THOR.084PR2, entitled "FLUID HANDLING SYSTEM," filed on March 13, 2013; United States Patent Application No. 13/801,833, which corresponds to attorney docket no. THOR.089A, entitled "SHEATH SYSTEM FOR CATHETER PUMP," filed on March 13, 2013; United States Patent Application No. 13/802,570, which corresponds to attorney docket no. THOR.090A, entitled "IMPELLER FOR CATHETER PUMP," filed on March 13, 2013; and United States Patent Application No. 13/802,468, which corresponds to attorney docket no. THOR.093A, entitled "MOTOR ASSEMBLY FOR CATHETER PUMP," filed on March 13, 2013.

[0053] Figure 4 shows a flat wall pattern 200 of a mesh structure 204 that is configured to provide enhanced flexibility in a distal zone 208. The distal zone 208 is disposed distally of an impeller zone 212, which is a portion of the mesh structure 204 that is disposed around an impeller in the catheter assembly of Figure 2. The impeller can be part of the impeller assembly 116, as set forth in more detail in the US Application No. 13/343,617, incorporated by reference above. In some embodiments, the distal zone 208 and the impeller zone 212 are distinct from each other, for example having separate structure or performance characteristics. In other embodiments, the distal and impeller zones 208, 212 are general regions of an otherwise continuous structure. In some embodiments, the distal and impeller zones overlap. The wall pattern 200 also includes distal and proximal end connection structures 216A, 216B, which are discussed in detail in the '617 application incorporated by reference above, and also in U.S. Application No. 13/343,618, which is hereby incorporated by reference herein in its entirety.

[0054] The wall pattern 200 illustrates a plurality of circumferential members 224 and a plurality of circumferential connectors 228. In the flat view of Figures 4 and 4A, the circumferential members 224 can be seen to extend transversely to a longitudinal axis of the pattern 200. In the formed view of Figures 5 and 5A, these structures can be seen to extend

about the circumference of the formed mesh structure 204. As discussed below, e.g., in connection with Figure 7 and 7A, a cannula is formed by enclosing the circumferential members 224 with a polymer material, e.g., a film, to create a flow channel open on the ends but otherwise sealed to maximize axial flow through the cannula and the pump. Thus, the circumferential members 224 and later the cannula are disposed about a space, e.g., a volume including at least the impeller zone 212.

[0055] In various embodiments, the polymer material is a coating disposed about the cannula mesh structure 204. Suitable materials for the polymer coating include, but are not limited to a biocompatible polymer, a drug-eluting polymer, and a functionalized polymer such as a thromboresistant material. In various embodiments, the polymer material is Hapflex™ or Thoralon™. In the exemplary structure, the polymer material fills the voids in the mesh structure. The polymer material also coats the inner and outer walls such that the mesh structure does not come into contact with blood and tissue. In various embodiments, the polymer material is a thin coating. In various embodiments, the polymer coating has a maximum thickness of less than 10 microns, less than 9 microns, less than 8 microns, less than 7 microns, less than 6 microns, less than 5 microns, less than 4 microns, less than 3 microns, less than 2 microns, or less than 1 micron. In various embodiments, the polymer coating is formed of a plurality of layers. In various embodiments, the polymer coating is configured to reinforce the mesh structure. The polymer material may be applied by dip coating, molding, spinning on a mandrel, or other techniques. One will appreciate from the description herein that the polymer coating may be configured and applied in various other manners. Further details of suitable materials are set forth in US Patent Nos. 4,675,361 and 6,939,377, which are incorporated by reference herein in their entireties and for all purposes.

[0056] The circumferential members 224 preferably are configured to be self-expandable, also described as self-expanding herein. Figure 4 shows that in one embodiment one or more of the circumferential members 224 can have an undulating configuration. As can be seen in many of the figures, and in Figure 4A specifically, circumferential members can have an alternating structure, e.g., a plurality proximal turns and distal turns connected by struts. The struts can be straight members that each have a proximal ends connected to a proximal turn and a distal end connected to a distal turn. The distal turns can be peaks and the proximal turns can be valleys, e.g., if the cannula is held with the distal end up. The

distal turns can be crests and the proximal turns can be troughs, e.g., if the cannula is held with the distal end up. In some cases, the circumferential members have a generally serpentine configuration, or can be sinusoidal in nature disposed on both sides of a transverse plane. The circumferential members 224 can include a plurality of distal and proximal apices 232A, 232B connected by elongate struts 236. As discussed further below, the density of the circumferential members 224 can be varied to modify the performance of the cannula.

[0057] The circumferential connectors 228 can be disposed between alternating struts 236 of adjacent circumferential members 224 in at least one of the distal and impeller zones 208, 212. For example, the connectors 228 (or other connectors discussed herein) can join a node on one circumferential member to a node on an adjacent circumferential member. In the case of the connectors 228, the nodes are offset from the peaks and valleys. At least one of the nodes can be disposed on a strut that extends between adjacent nodes. In some cases, connectors are disposed between the crests and trough and can be disposed between a crest the a transverse mid-point of a sinusoidal circumferential member. In some patterns, the width of nodes are greater in the impeller zone than distal thereof. Figure 4 shows that circumferential connector 228 can be provided between opposing sides of adjacent struts 236 of at least two adjacent circumferential members 224 in the impeller zone. In one embodiment, alternating elongate struts 236 are connected to an adjacent elongate strut of an adjacent circumferential member 224. In one embodiment, alternating elongate struts 236 are not connected to adjacent elongate struts by circumferential connectors 228. The elongate struts 236 that are not connected by circumferential connectors 228 are able to expand to a greater degree, providing for asymmetrical expansion about an apex in some embodiments. In this context, asymmetrical can refer to unequal movement upon expansion of the elongate struts 236 away from a central axis extending through an unexpanded apex. The central axis can be an axis intersecting an apex and being located equal distance from inner edges of unexpanded adjacent elongate struts 236.

[0058] Figure 4 shows that while circumferential connectors 228 are provided in the impeller zone 212, the connectors 228 can be omitted in the distal zone 208. Such an arrangement provides enhanced rigidity of the impeller zone 212 compared to the distal zone 208. Figures 6 and 14A-1 to 14A-3 are other embodiments in which circumferential connectors 228 are provide throughout a distal zone as well as in an impeller zone. More

generally, the circumferential connectors 228 can be provided between opposing sides of alternating adjacent elongate struts of less than all of the circumferential members in the distal zone 208, while still providing benefits as discussed below. For example, a substantial portion such as one-half or more of the struts 236 can be connected by circumferential connectors 228 in the distal portion in one embodiment. In some embodiments, the density of connectors 228 in the distal zone 208 can be about one-half or less that in the impeller zone 212.

[0059] In various embodiments, there can be different groups of circumferential connectors 228. For example, in Figure 4 two groups of circumferential connectors 228A, 228B can be provided. A first plurality connectors 228A can be provided about the impeller zone 212 in which the connectors have a length along the struts 236 that the connectors 228A join that is greater than the separation between adjacent circumferential members, e.g. between the struts 236 that they join. The length of the connectors 228A along the struts 236 that they join is greater than the separation between adjacent circumferential members in the unexpanded state in some embodiments. A second plurality connectors 228B can be provided between the impeller and distal zones 212, 208 in which the connectors have a length along the struts 236 that they join that is less than the length of the connectors 228A. For example, the length of each of the connectors 228B along the struts 236 to which they are coupled can be about one-half that of the first connectors 228A. By providing longer connectors 228A, enhanced stiffness can be provided in the impeller zone 212. This can aid in collapsing the cannula, as discussed below. Longer connectors 228A also contributes to dimensional stability of the impeller zone 212, e.g., to minimize variance of a gap between a tip of an impeller and an inner surface of the cannula in the impeller zone 212.

[0060] Figure 4A shows details of a portion of the distal zone 208. For example, a plurality of axial connectors 252 can be provided between proximal side of a proximal apex and a distal side of an adjacent circumferential member in the distal zone of the cannula. The same connectors can be provided in the impeller zone 212. Figure 4 shows that in some embodiments a modified axial connector 252A can be provided in the impeller zone 212. The connectors 252A have a first end that forms an apical connection with a proximally oriented apex 232B and a second end. The second end is coupled in between adjacent apices of a circumferential member, e.g., along a side of an elongate strut 236. The connectors

252A can be connected to the struts 236 at the same location that the strut connects to an adjacent strut by way of the connector 228A. The connectors 252A are shortened compared to the connectors 252. For example, they can extend with fewer undulations along their length, e.g., with a single inflection point between the ends.

[0061] In one embodiment, substantially all of the impeller zone 212 has enhanced rigidity connectors 252A. Figure 5 shows a transition zone that can be provided at one or both of the proximal and distal ends of the impeller zone 212. For example, a transition zone TZ-B can be provided to facilitate radial transition from the expanded size of the formed mesh to the diameter of a non-expanding portion 254 of the formed mesh that does not expand. A transition zone TZ-A between the impeller and distal zones can provide for more gradual change in mechanical characteristics to provide for gradual collapse of the cannula, as discussed below.

[0062] Figure 5 shows an expanded mesh structure 204 formed of the pattern 200. The mesh structure 204 comprises a plurality of spaced apart helical zones 260. The helical zones 260 are formed by adjacent struts 236 that have less or no movement relative to each other during expansion, where connectors 228 are provided. Adjacent struts that are connected by connectors 228 tend to move or expand less than struts that are not so connected, or do not move or expand at all. Figures 5 and 5A shows that the helical zones 260 are in the impeller zone 212 and not in the distal zone. The helical zones 260 provide enhanced concentration of material around the proximal apices 232B of circumferential members 224 in the impeller zone 212. Enhanced concentration of material provides enhanced local stiffness around the proximal apices 232B, which provides greater stiffness and protects the proximal apices 232B and connectors disposed thereon from fracture. As discussed more below in connection with Figure 12, in some variants proximal apices in a zone (e.g., a distal zone) are omitted but the helical zones are induced to preserve this protective structure around the proximal apices. Such arrangements aid in the re-sheathing of a cannula incorporating this structure.

[0063] Enhanced concentration of material (e.g., increased struts per unit area) makes the connection between the apices 232B and adjacent proximal circumferential member 224 more robust. In particular, larger forces are encountered in the impeller zone

212 during collapsing of, sometimes referred to as re-sheathing of, the cannula, e.g., after the catheter pump has been used.

[0064] Figure 17 shows a graph of axial force that may be required to be applied to an outer sheath, such as by the sheath assembly 88, disposed about the catheter body 120 (see Figure 2) as the sheath assembly is advanced distally along the cannula. This figure shows that in region A the force is relatively high when the distal end of the sheath initially engages the proximal end of the expanded zone of the cannula. The force also increases in a region B to a relatively high level when the distal end of the outer sheath is advanced to a location over the proximal end of the impeller. At each of these locations, the clinicians will note increased resistance to advancement of the sheath to collapse the impeller and/or the cannula and to draw the impeller and/or the cannula into the outer sheath, sometimes referred to herein as re-sheathing. From this graph, an increased risk of failure of one or more connections within the mesh of the cannula being tested has been discovered in these regions of local maxima. Surprisingly, however, various cannulae that have been tested have failed in the lower force region to the right of region B. As a result, there is a surprising benefit to be obtained in enhancing the robustness of the cannula in a region distal of the impeller zone. As discussed herein, the robustness can be enhanced in any one or all of a variety of ways, such as shortening axially oriented connectors between adjacent circumferential members, increasing material per unit area in a region around proximally oriented apices, providing an expanded configuration in which struts of the mesh are positioned close together around a weak point in the mesh structure, and other ways described herein.

[0065] Figures 4-5A and other embodiments herein illustrate some specific ways of improving the reliability of an expandable cannula, which can help to minimize the risk of breakage within the mesh, e.g., breakage of the connectors 252A. A first technique is making the connectors 252A shorter than the connectors 252. A second technique involves the enhanced concentration of material around the proximal apices 232B, discussed above.

[0066] The distal zone 208 is substantially free of the helical zones 260 or other concentration of material in the embodiment of Figure 4-5A. In the distal zone 208, the struts 236 expand substantially symmetrically about the apices 232A forming a more uniform expanded mesh in the distal zone 208. This arrangement enhances the overall flexibility of the distal zone 208, which can be beneficial. Also, this arrangement makes local zones of the

expanded mesh structure 204 substantially uniformly flexible. A mesh structure 204 with a more flexible distal zone 208, and more uniform flexibility, can provide a cannula with a reduced risk of irritating the inner structures of the heart when deployed.

[0067] Figure 6 shows an embodiment, in which the distal zone 208 is modified to minimize a risk of fracturing connectors in the distal zone. For example, a first plurality of axial connectors 272 is disposed between a proximal side of a proximal apex 232B and a distal side of an adjacent circumferential member 224 in the impeller zone 212. Figure 6A shows a second plurality of axial connectors 272A is disposed between a proximal side of a proximal apex 232B and a distal side of an adjacent circumferential member 224 in the distal zone 208 of the cannula. In the illustrated embodiment, connectors 272A are provided between proximal apices 232B and a middle portion of the elongate members 236. The axial connectors 272A of the second plurality have first and second ends, and a single curved section therebetween. In contrast, the axial connectors 272 of the first plurality have first and second ends, and a plurality of curved section therebetween. Stated another way, the axial connectors 272 have multiple undulations and the connectors 272A have a fewer undulation, e.g., a single curved section.

[0068] Also, the distal zone 208 can be made less susceptible to fracture by providing circumferential connectors 228 in some embodiments. In the illustrated embodiment, every other elongate struts 236 of a circumferential member 224 in the distal zone 208 is connected to an adjacent elongate struts 236.

[0069] Figures 7-7A show a cannula 296 incorporating the formed shape of a mesh with some features similar to those of the flat pattern of Figures 6 and 6A. In this embodiment the helical zones 260 are provided throughout the cannula 296. In the embodiment of Figures 7-7A, apex-to-side connectors each have a plurality of undulations along their length, similar to the connectors 272. However, providing side-to-side connectors 228 throughout the length of the cannula 296 enhances the concentration of material around the apex-to-side connectors. As such, the load applied by the advancement of the sheath over the cannula is spread out over a greater area and a smaller load is concentrated in the apex-to-side connectors. These are examples of techniques for minimizing the chance of fracture of connectors similar to the connectors 272, 272A.

[0070] Figures 8 and 9 illustrate an embodiment that is similar to that of Figures 6 and 7. Figures 8 and 9 show a wall pattern 300 and a mesh structure 304 that is configured to provide a good compromise of fracture resistance and flexibility for interaction with heart tissue. The impeller zone 312 has a plurality of circumferential connectors 328 whereas the distal zone 308 is substantially free of circumferential connectors. This provides an impeller zone with spaced apart helical zones, as discussed above, and a distal zone with substantially symmetrical expansion about proximally and/or distally oriented apices thereof. By removing the circumferential connectors in the distal zone, the distal zone is made more flexible. Axial connectors 352 are provided throughout the pattern 300, but the distal zone 308 is provided with axial connectors 352A that are less subject to fracture. For example, the connectors 352A can be limited to fewer undulations than in the connectors 352 in the impeller zone 312, as discussed above.

[0071] Figures 10 and 11 illustrate an embodiment that is similar to that of Figures 6 and 7. Figure 10 shows a wall pattern 400 that has a higher concentration of material in the impeller zone 412. Higher concentration of material can be achieved by more tightly packing the apices of the undulating structure of the circumferential members. For example, an angle can be formed between adjacent elongate struts 436 disposed on opposite sides of each of the apices. The angle can be smaller in the embodiment of Figures 10 and 11 compared to that of Figures 6 and 7. Also, in order to provide more flexibility compared to the pattern of Figures 6 and 7, the pattern of Figures 10 and 11 omits circumferential connectors in the distal zone 408.

[0072] One technique for minimizing fracture risk in the distal zone 408 is to configure the mesh structure 404 to produce helical zones 460 throughout the structure, including in the distal zone 408 where there are no circumferential connectors. This can be achieved by heat setting the expanded shape in a material that would operate in an elastic range in this application. For example, nitinol can be configured to be compressed for delivery and heat set to expand to the shape seen in Figure 11. This arrangement may provide good flexibility in the distal portion 408 and resistance to fracture of connectors between adjacent circumferential members 424.

[0073] Figures 12-14 illustrate an embodiment in which at least a distal zone is configured to be resistant to fracture. Figures 12 and 13 show that in one embodiment, short

connectors 452 are positioned in the distal zone. The short connectors 452 can be similar to those discussed above, e.g. having only a single curve or inflection between ends thereof. In one configuration, the short connectors 452 can have a length that is no more than about ten times the thickness of the outer sheath used to collapse the cannula. For example, these connectors can be about 0.035 inches long or less. The connectors 452 can be robust in their own right to permit a symmetrical expanded configuration for the distal zone of the wall pattern. Symmetrically expanded apices can provide some advantages, e.g., providing more uniform flexibility with the mesh structure, as discussed above. In some embodiments another technique can be used to spread a load applied by an outer sheath to the cannula incorporating the mesh illustrated in these figures. By spreading the load, the mesh is less subject to fracture.

[0074] The pattern arrangements in FIGs. 10-14 also reduce stress and strain on the connectors by subjecting them to more pulling and less twisting during expansion and collapse of the mesh structure. Another advantage of these designs is that they tend to deflect the proximally oriented apices radially inward as the sheath approaches the proximally oriented apices so that a distal face of the sheath does not become lodged beneath the proximally oriented apices. In the heat set distal portion illustrated in Figure 14, each connector 452 is disposed distal of a portion of an elongate strut 436. The connectors 452 also can be located axially behind the elongate struts 436. In contrast, in the embodiment of Figure 13, the connector 452 is disposed distal of the nearest proximally oriented apex. The elongate struts 436 in the Figure 14 embodiment, helps guide the approaching outer sheath over the top of the proximally oriented apices. The elongate struts 436 also locally deflect the cannula in a zone between the connectors 452 and the outer sheath as the sheath approaches individual connectors to minimize any tendency of the connectors 452 deforming around the distal end of the sheath and later breaking.

[0075] Another approach to easing re-sheathing involves reducing an amount of open area in the formed cannula wall pattern around relative stiff proximally oriented structures. For example, the axially oriented undulating connectors in Figure 5A may be more prone to fracture. At least two factors contribute to this. First, these connectors are relatively long. Also, they are surrounded on both sides by large areas not spanned by struts of the mesh pattern. These areas are covered with a polymer material to enclose a cannula.

However upon re-sheathing this polymer material can ride over the outer surface of the outer sheath causing the proximal apices to ride over the outside of the sheath. This can lead to breakage of the axially oriented undulating connectors in Figure 5A. This is input because the axially oriented connectors are relatively thin in at least one cross-sectional dimension and are formed of somewhat ductile metal. Figure 13 shows the connectors 452 shortened to minimize this effect. Figure 14 shows an embodiment in which more struts are placed around at least one side of the short connectors 452 in the helical zones 460. Additionally, circumferential connectors can be provided in the distal zone for this purpose, as discussed herein.

[0076] Figure 14A-1 to 14A-3 show a proximal portion 462A, a central portion 462B, and a distal portion 462C of a wall pattern 462. Each of the portions 462A, B, C has a plurality of circumferential members 466 in a relatively high metal density structure. The circumferential members 466 are close to each other in each of these portions. The members 466 have undulating configurations, e.g., with peaks and valleys. The peaks and valleys of neighboring members 466 can be received within each other, as shown in the figures. The proximal portion 462A is configured to enhance structural integrity of the wall surrounding the impeller. Advantages for this arrangement are discussed above, and include minimizing variation in the gap between the tip of the impeller and the inner wall of the cannula into which the pattern of Figures 14A-1 to 14A-3 is incorporated. In the illustrated embodiment, the stiffness of the proximal portion 462A is enhanced by providing a plurality of elongate circumferential connectors 470. The advantages of this sort of connector are discussed above, and include minimizing expansion of elongate struts 474 which are coupled by the connectors 470.

[0077] As shown in Figure 7 an expanded cannula with connectors 470 will have an expanded configuration including spaced apart helical spines that arise from the minimal to no displacement of the struts 474 that are connected by the connectors 470. The spines or other configurations including a connector 470 and a plurality of struts connected thereby advantageously provide areas of enhanced stiffness and/or strength in the wall of a cannula having the pattern 462. Such regions can support an outward load without significant deflection. One outward load that can arise in operation is due to the fluid flowing in the cannula. Although the impeller is configured to primarily drive the blood axially the

rotational movement may push blood into the inside wall of the cannula. The spines or other areas of enhanced stiffness can minimize deflection due to this load. Another outward load can be applied by a distal bearing structure such as that described in concurrently filed Application No. 13/802,556 which corresponds to attorney docket no. THOR.072A, entitled "DISTAL BEARING SUPPORT," filed on March 13, 2013, which is hereby incorporated herein by reference in its entirety.

[0078] In addition to the connectors 470, 470A, the pattern 462 includes connectors 476 disposed between proximal oriented apices (or valleys, if the pattern is held distal end up) and distal edge of a circumferential member disposed proximally of the apex. The connectors 476 are relatively slender in order to permit the apices to which they are connected to flex upon expansion and collapse of the cannula into which the wall pattern 462 is incorporated. The proximal portion 462A also provides enhanced concentration of material around the connectors 476 to minimize a chance of fracturing these connectors upon expansion and collapse of the cannula.

[0079] Figure 14A-1 illustrates a pattern in the proximal portion 462A providing a high metal density cannula. The pattern has an embedded ring structure, which provides a first ring with a vertex of at least one adjacent ring within the axial length of the first ring. Figure 14A-1 illustrates embodiments where there are 2 or more adjacent vertices within the axial length of the first ring. There are several benefits of the embedded design for the pump 10. The embedded design provides additional radial strength by increasing the number of load bearing rings per length of cannula. The embedded design minimizes the unsupported film area, which decreases the amount the film can flex as the pressure pulses generated by the impeller pass under it.

[0080] Other methods can be used to provide some of these benefits, include making the axial length of the rings shorter and increasing the number of sinusoidal waves within a ring. These features will result in other changes to the cannula pattern. Shorter rings tend to increase the strain the material must undergo in changing from the collapsed to expanded state. Suitable materials, such as nitinol, may be more prone to permanent deformation or fracture with increasing strain. Increasing the number of sinusoidal waves within a ring increases the diameter of the collapsed cannula, if other relevant factors (such

as strut width) remains the same, may reduce the stress and strain to which the struts are subjected.

[0081] Other cannula patterns can be provided to reduce unsupported film area without increasing the number of embedded rings. For example, an arm feature could be added between two struts of adjacent rings. As the cannula transforms from the collapsed to expanded form, the arm orientation moves from a more axial to more radial orientation (in some cases, forming an "A" shape). More details of these structures are set forth in connection with Figures 15-16 below.

[0082] In a transition zone between the proximal portion 462A and the central portion 462B, modified connectors 470A are provided that are much shorter in a direction parallel to the longitudinal axis of the struts 474 than are the connectors 470. The shorter connectors 470A make the central portion 462B much more flexible than the proximal portion 462A. Such flexibility can provide less irritation to heart tissue and than higher biocompatibility as discussed elsewhere herein. Figure 14 shows that the connectors 470A also are provided in the distal portion 462C.

[0083] A proximal end of each of the connectors 476 is coupled to a portion of the strut 474 that is also connected to the connector 470 or 470A. This structure provides a concentration of material around the more flexible and elongate connector 476 to minimize the chance of fracture of this structure when the cannula is collapsed by a sheath, as discussed herein. Because the sheathing forces are less in the distal portion of the cannula corresponding to the distal portion 462C, the concentration of material in the distal portion 462C around the connectors 476 can be less than in the proximal portion 462A.

[0084] Various additional advantageous features are found on the proximal and distal portions 462A, 472C in various embodiments. For example, when the pattern 462 is formed a sheet-like zone 480 is provided that is advantageous for mechanically integrating the pattern 462 into various catheter bodies in an assembly. A plurality of cantilevered projections 482 is disposed in the sheet-like zone 480 and is disposed about the circumference of the proximal portion 462A when the pattern 462 is formed into a tubular body. The projections 482 can be deflected into mating recesses in the catheter body 84 or another structure of a catheter assembly to provide a resistance to detachment of the pattern 462 (and the cannula into which it is incorporated) from the catheter body or assembly. Such

resistance advantageously minimizes inadvertent separation of the cannula from the catheter body 84 during re-sheathing.

[0085] Also, the peak-to-peak distance between the proximal-most circumferential member 466 and the circumferential member immediately distal thereof is greater than the average peak-to-peak distance of adjacent circumferential members distal thereof. A consequence of this is that the connector 470 between the proximal-most circumferential member and the adjacent circumferential member is located closer to the peaks of the proximal most circumferential member. This creates an enlarged space 488 that aids in transitioning the diameter of the expanded cannula into which the pattern 462 is incorporated from a larger size disposed about the impeller to the diameter of the sheet-like zone 480 when formed into a tubular body.

[0086] The distal portion 462C of the wall pattern includes elongate members 490 that are for mechanically integrating the pattern into a catheter assembly. The elongate members 490 extend from distal apices of the distal portion 462C of the pattern 462. The connectors 470A and 476 disposed between the distal-most circumferential member 466 are shifted closer to the peak of the adjacent circumferential member 466 such that a larger space 492 is provided between the distal-most two circumferential members 466. The shifting of these connectors provides a larger peak-to-peak distance between the distal-most two circumferential members 466 than is provided between other circumferential members of the pattern 462. By increasing this distance, the transition from the enlarged diameter of the expanded cannula into which the pattern is incorporated to the smaller diameter of distally located non-expandable components of a catheter assembly can be facilitated.

[0087] Figures 15 and 15A illustrate another embodiment of a wall pattern 500 that can be combined any features of any of the wall patterns herein. These embodiments illustrate a proximal zone of the pattern that forms a transition zone between a non-expandable proximal portion 554 of a cannula and an impeller zone 512. One feature of a cannula formed from the wall pattern 500 is the provision of a larger number of flow passages between inside of the proximal portion of the cannula and outside of the proximal portion thereof. A first outflow area is provided in one embodiment adjacent to the proximal end of the expandable portion of the cannula. In some embodiments, a second outflow area 520 is provided distal of the first outflow area. The first and second outflow areas 518, 520

can take any suitable form. In the illustrated embodiment, the first outflow area is defined between a distal edge or side of a first circumferential member 524A and a proximal edge or side of a second circumferential member 524B.

[0088] Figure 16 shows the expanded configuration of one of a first plurality of openings 528A formed in a mesh. Comparing Figures 15A and 16 one can see that the plurality of openings can include four openings 528A formed defined within the members 524A, 524B and connectors extending therebetween. The connectors can take any suitable form, such as those discussed above. In the illustrated embodiment, the second outflow area is defined between a distal side or edge of the second circumferential member 524B and a proximal side or edge of a third circumferential member 524C. More particularly, a plurality of openings 528B in a mesh, e.g. four opening, formed by the pattern 500 are defined within the members 524B, 524C and connectors extending therebetween. The connectors can take any suitable form, such as those discussed above.

[0089] Figure 16 shows a cross-hatched zone distal of the openings 528A, 528B. The cross-hatched zone illustrates the area of the mesh structure that is covered to enclose the space within the mesh structure. Comparing Figure 16 with Figure 9, one can appreciate that the openings 528A are inclined with respect to the longitudinal axis of the spaced enclosed therein and the openings 528B are less inclined and in some cases may be disposed on a substantially cylindrical surface about the longitudinal axis of the cannula. In this context, the concept of conforming to a cylindrical surface can be measured when the device is expanded but not implanted or in use. The mesh structure 500 should advantageously provide beneficial flow characteristics compared to an arrangement that only has flow openings 528A. For example, by providing the flow openings 528B (or other variant of a second outflow area 520), the average flow velocity into or out of the cannula can be decreased. By decreasing the average flow velocity, stress on the blood cells can be reduced. Such stresses can be due to shear forces across the boundary into or out of the cannula. Lower stresses on red blood cells can lessen hemolysis or other harm to the blood.

[0090] Figures 15-16 also illustrate the use of a circumferential connector 530 that is configured to reduce the extent of an unsupported portion of a structure enclosing a lumen within the mesh 500 after the mesh is formed into a cylinder. The connector has a proximal end 530B coupled with a proximal circumferential member 524B and a distal end

530C coupled with a circumferential member 524C that is located distal of the circumferential member 524B. The length of the connector 530 is several times the unexpanded separation distance between the adjacent struts of the circumferential members 524B, 524C. The length of the connector 530 enables the adjacent struts of the circumferential members 524B, 524C to move away from each other to a much greater extent than permitted by the short circumferential connectors 470. In the collapsed state, the connector 530 can be shaped to tightly nestle between the circumferential members 524B, 524C, for example, having a concave portion adapted to receive a portion of a crest of the circumferential members 524B. In some embodiments, the connector 530 enables the adjacent struts of the circumferential members 524B, 524C to move away from each other to the same extent as if these struts were not connected by a circumferential member. See, for example, the struts of the circumferential members that are not connected by circumferential connectors in the expanded cannula shown in Figure 7A. However, as can be seen in Figure 16, the presence of the connector 530 greatly reduces the extent of the unsupported area between adjacent struts.

[0091] In one embodiment, the connector 530 is connected approximately in the middle of adjacent struts, e.g., half way between adjacent peaks and valleys on each circumferential member. This arrangement roughly reduced by 50 percent the unsupported area between these struts. Long slender struts may be more prone to shearing upon being collapsed into the sheath. Accordingly, it may be desirable to locate the struts 530 in areas of local minima of a sheathing force curve as discussed below in connection with Figure 17. In other embodiments, the connectors 530 are located away from areas of local maxima of a sheathing force curve as discussed below in connection with Figure 17.

[0092] Figures 5, 7, and 17 illustrate further advantageous features of wall patterns. In particular, as noted above, a local maximum in the force-distance curve of Figure 17 is the region A, which corresponds to a transition zone between the non-expandable part of the mesh and the expandable impeller zone. The test illustrated in Figure 17 shows that this local maximum exceeds a threshold number that is based on clinician ease-of-use. One technique for reducing the level of this local maximum is to provide a shallower angle of the transition zone. In particular, an angle β can be provided between this inclined surface and a horizontal axis, e.g., an axis parallel to the undeflected longitudinal axis of the cannula.

Figure 7 shows a smaller angle than that of Figure 5. Preferably the angle β is within a range of from about 30 to about 40 degrees, in some embodiments not more than about 40 degrees. To reduce the force required for re-sheathing, the angle β can be maintained at about 30 degrees or less. The angle β may be maintained above a value that is a function of the trackability of the catheter assembly into which the mesh structure is incorporated. If the angle is too low, the length of the cannula or portions thereof may result in a too stiff cannula to properly track. Another advantage of the shallower angles suggested by Figures 7 and 17 is that the impeller zone in a cannula incorporating this pattern is expected to be stiffer. This is one technique for providing better control of a gap between the impeller blade tip and the cannula wall. This tip gap control can advantageously minimize hemolysis and other damage to the blood, as well as any damage to the wall or blades that could be caused by impact therebetween.

[0093] The foregoing features of mesh patterns can be combined with other features for improving tip gap control. Such features can be incorporated into a distal bearing, as discussed in concurrently filed United States Patent Application No. 13/802,556, which corresponds to attorney docket no. THOR.072A, entitled "DISTAL BEARING SUPPORT," filed on March 13, 2013; and/or in impeller or impeller blade construction, as discussed in United States Patent Application No. 13/802,570, which corresponds to attorney docket no. THOR.090A, entitled "IMPELLER FOR CATHETER PUMP," filed on March 13, 2013. Both of these applications are incorporated by reference herein in their entirety.

[0094] Although the inventions herein have been described with reference to particular embodiments, it is to be understood that these embodiments are merely illustrative of the principles and applications of the present inventions. It is therefore to be understood that numerous modifications can be made to the illustrative embodiments and that other arrangements can be devised without departing from the spirit and scope of the present inventions as defined by the appended claims. Thus, it is intended that the present application cover the modifications and variations of these embodiments and their equivalents.

WHAT IS CLAIMED IS:

1. An apparatus for inducing motion of a fluid relative to the apparatus, comprising:

a rotatable impeller; and

an elongate cannula defining a blood flow channel in which the impeller is disposed, the cannula comprising an expandable structure comprising:

a plurality of circumferential members disposed about the blood flow channel, the circumferential members having an undulating configuration including a plurality of apices connected by elongate struts;

a plurality of circumferential connectors disposed between alternating struts of adjacent circumferential members; and

a plurality of axial connectors comprising a distal end coupled with a proximal side of a proximal apex of a first circumferential member, a proximal end coupled with a distal face of a second circumferential member disposed adjacent to and proximal of the first circumferential member, and an arcuate section disposed therebetween, wherein the arcuate section comprises a single convex portion disposed between the proximal and distal ends.

2. The apparatus of Claim 1, wherein the elongate cannula comprises an impeller zone disposed about the impeller and a distal zone disposed distal of the impeller zone, and wherein the axial connectors comprise a first plurality and further comprising:

a second plurality of axial connectors is disposed between a proximal side of a proximal apex and a distal side of an adjacent circumferential member in the distal zone of the cannula, the axial connectors of the second plurality being more flexible than the axial connectors of the first plurality.

3. The apparatus of Claim 1, further comprising an enclosure comprising polyurethane disposed about the circumferential members to enclose a lumen along a length of the cannula between an inlet and an outlet.

4. An apparatus for pumping blood, comprising:

a rotatable impeller;

an elongate cannula having a plurality of circumferential members disposed about the impeller, one or more of the circumferential members having an undulating

configuration including a plurality of proximal and distal apices, each proximal apex connected to a distal apex by an elongate strut; and

an axial member having a distal end coupled with a proximal apex of a first circumferential member a proximal end coupled with a second circumferential member disposed proximal of the first circumferential member, the axial members having a length that is less than the distance between the proximal apex to which the distal end of the axial member is connected and a proximal apex of the second circumferential member that is axially aligned with the proximal apex to which the distal end of the axial member is connected.

5. The apparatus of Claim 4, wherein the elongated cannula comprises a region of enhanced local stiffness around the proximal apices.

6. The apparatus of Claim 5, wherein a circumferential connector is disposed between alternating adjacent elongate struts of a pair of adjacent circumferential members throughout a distal zone of the cannula.

7. The apparatus of Claim 5, wherein each apex in a distal zone of the cannula is configured such that upon expansion a first lateral side adjacent to each apex moves away from an axial centerline of the apex by a greater amount than a second lateral side adjacent the apex, such that circumferentially spaced zones of high strut concentration are formed adjacent to proximal apices.

8. The apparatus of Claim 7, wherein opposing sides of alternating elongate struts of at least two adjacent circumferential members in the distal zone are not connected by circumferential connectors.

9. The apparatus of Claim 8, wherein the cannula comprises a first length disposed over the impeller having a first stiffness and a second length disposed distal to the impeller having a second stiffness less than the first stiffness.

10. The apparatus of Claim 7, wherein a circumferential connector is provided between opposing sides of alternating adjacent elongate struts of at least two adjacent circumferential members in the distal zone.

11. The apparatus of Claim 10, wherein each circumferential member in the distal zone is to another circumferential member by a circumferential connector.

12. The apparatus of Claim 11, wherein at least about one-half of the struts in the distal zone are connected by circumferential connectors.

13. The apparatus of Claim 4, further comprising a sheath configured to be positioned over the elongate cannula to move the cannula from an expanded configuration to a collapsed configuration.

14. The apparatus of Claim 4, further comprising a biocompatible polymeric film disposed about the circumferential members to enclose a lumen along a length of the cannula between an inlet and an outlet.

15. The apparatus of Claim 14, further comprising a film support member having a first end connected to an elongate strut of a first circumferential member and a second end connected to an elongate strut of a second circumferential member, the film support having a length greater than the distance between the first and second circumferential members in the unexpanded state of the cannula, the film support member segmenting an area defined between the adjacent circumferential members to reduce the unsupported area of the film.

16. A catheter pump, comprising:

a rotatable impeller; and

an elongate cannula having a mesh comprising a plurality of circumferential members disposed about the impeller and a plurality of axial connector extending between a proximal side of a distal circumferential member and a distal side of a proximal circumferential member, the circumferential members being radially self-expandable;

wherein the cannula is configured to minimize fracture at least within the distal zone of the mesh as the elongated cannula moves into a sheathing device.

17. The apparatus of Claim 16, wherein the circumferential members have an undulating configuration including a plurality of proximal and distal apices, proximal and distal apices being connected by elongate struts, the struts being located laterally of a plane intersecting the apices and a central longitudinal axis of the cannula and being intersected by a plane intersecting an adjacent apex and the central longitudinal axis of the cannula.

18. The apparatus of Claim 16, the elongate cannula having an impeller zone over the impeller and a distal zone disposed distally of the impeller zone, the distal zone having

enhanced concentration of struts per unit area about the axial connector when the cannula is expanded.

19. The apparatus of Claim 18, wherein the mesh pattern of the impeller zone and the mesh pattern of the distal zone are different.

20. The apparatus of Claim 19, wherein when expanded, the cannula comprises a plurality of spaced apart helical zones with enhanced concentration of struts per unit area formed.

21. The apparatus of Claims 16, wherein axial connectors are provided between adjacent circumferential members, the axial connectors having an apex connection, a strut connection, and a single inflection disposed therebetween.

22. The apparatus of Claim 16, further comprising a plurality of circumferential connectors extending between alternating adjacent elongate struts of a pair of adjacent circumferential member.

23. The apparatus of Claim 22, the elongate cannula having an impeller zone over the impeller and a distal zone disposed distally of the impeller zone, wherein the plurality of circumferential connectors comprise a first plurality disposed in the impeller zone and a second plurality disposed in the distal zone of the cannula, the first plurality of connectors providing greater stiffness than the second plurality of connectors.

24. The apparatus of Claim 23, connectors of the first plurality have a length along the struts that is greater than the separation between adjacent circumferential members.

25. The apparatus of Claim 24, wherein each circumferential member is connected to at least one other circumferential connector by the axial connector disposed therebetween.

26. The apparatus of Claim 23, connectors of the first plurality have a length that is at least about two times the separation between adjacent circumferential members connected by connectors of the first plurality.

27. The apparatus of Claim 23, wherein connectors of the first plurality and the struts joined thereby provide greater concentration of material per unit area than the connectors of the second plurality and the struts joined thereby.

28. The apparatus of Claim 27, further comprising an enclosure comprising polyurethane disposed about the mesh structure to enclose a lumen along a length of the cannula between an inlet and an outlet.

29. An cannula for conveying blood, comprising:

an in-situ expandable and collapsible mesh structure comprising a plurality of undulating circumferential members surrounding a lumen, each circumferential member having proximal and distal vertices; and

a polymeric enclosure disposed about the mesh structure to enclose the lumen along a length between an inlet and an outlet;

wherein the number of proximal vertices in an area defined between a proximal circumference intersecting the proximal vertex of a circumferential member and a distal circumference intersecting the distal vertex of the same circumferential member adjacent to the proximal vertex is at least two.

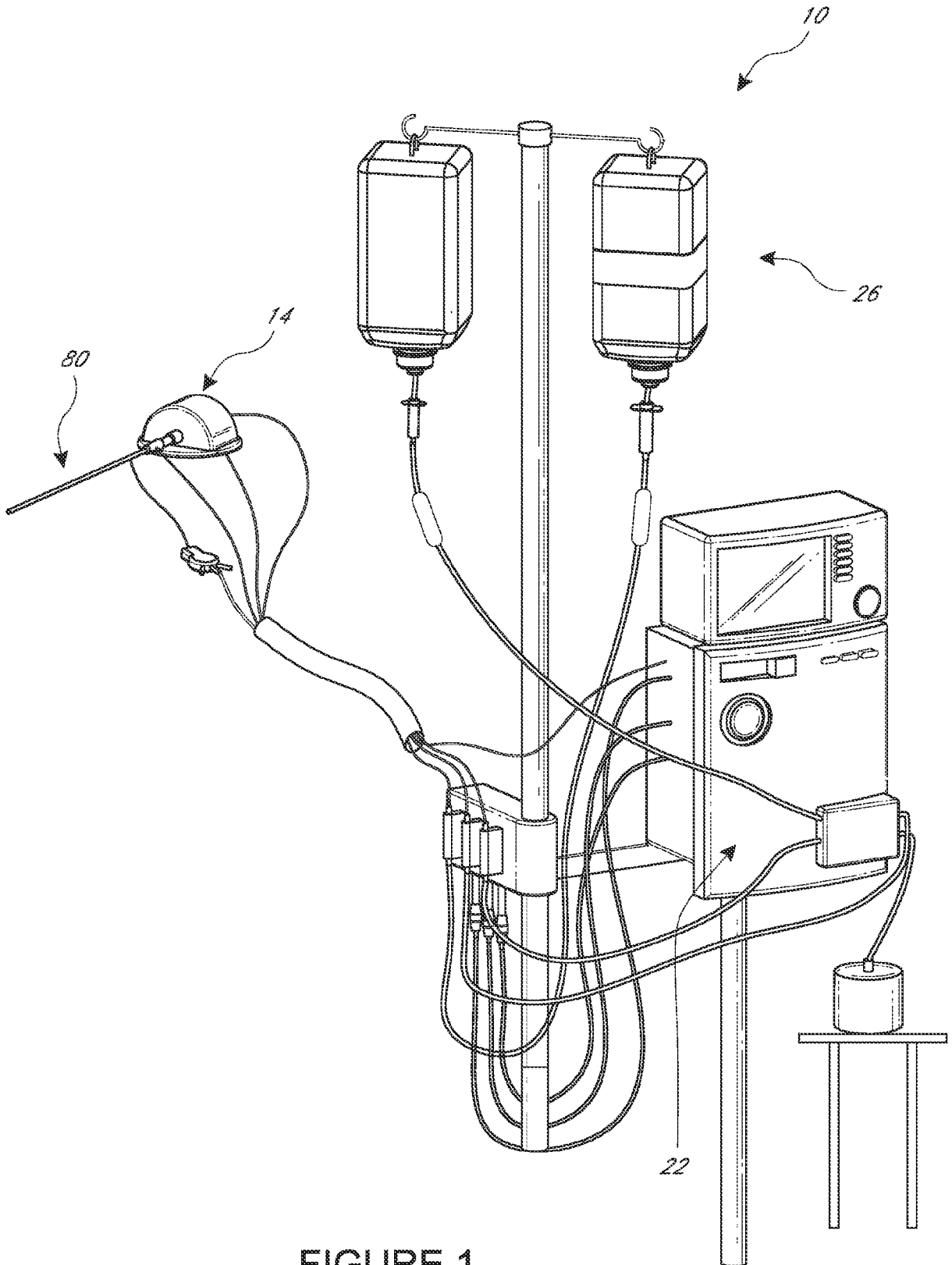
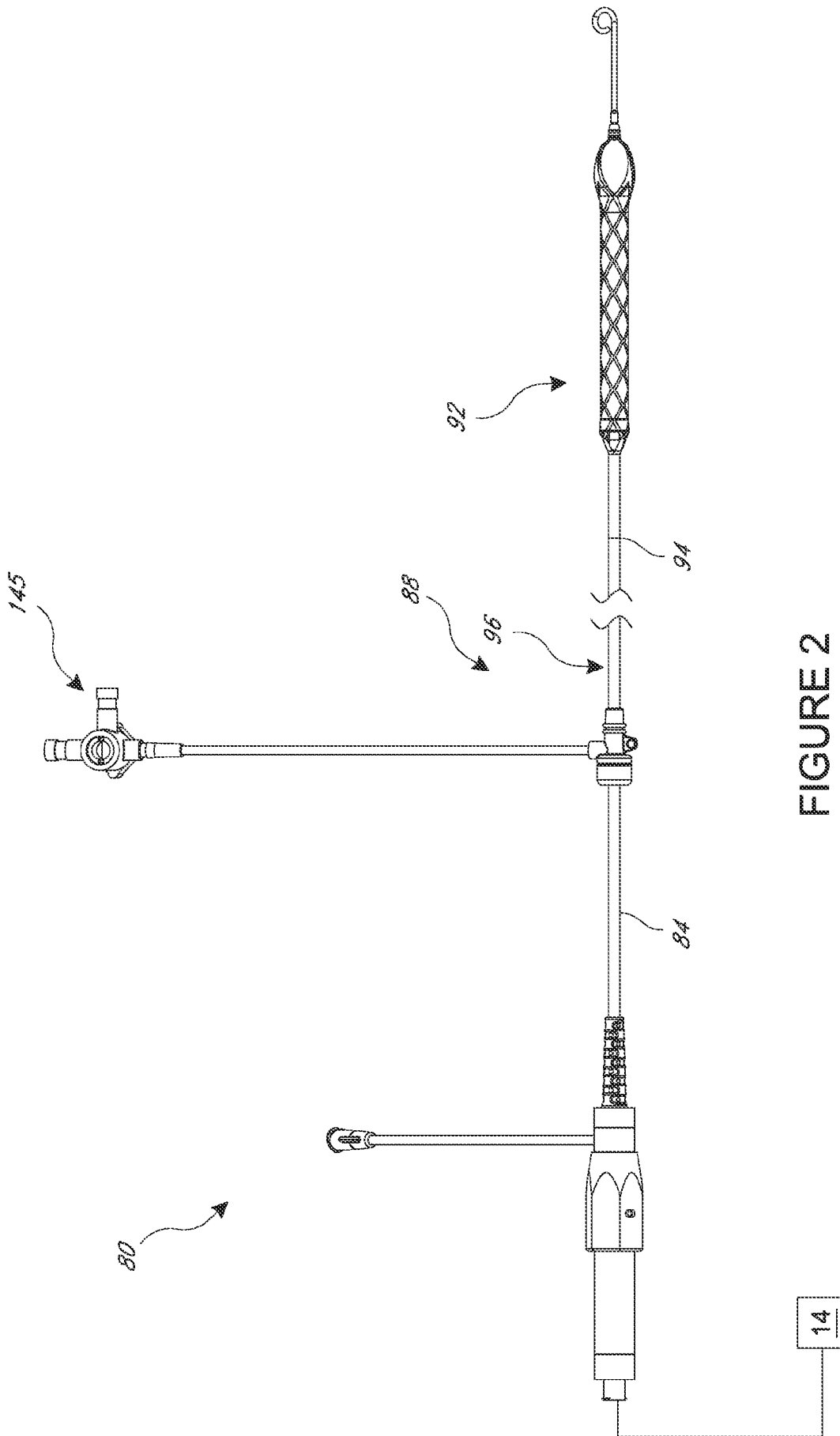

FIGURE 1



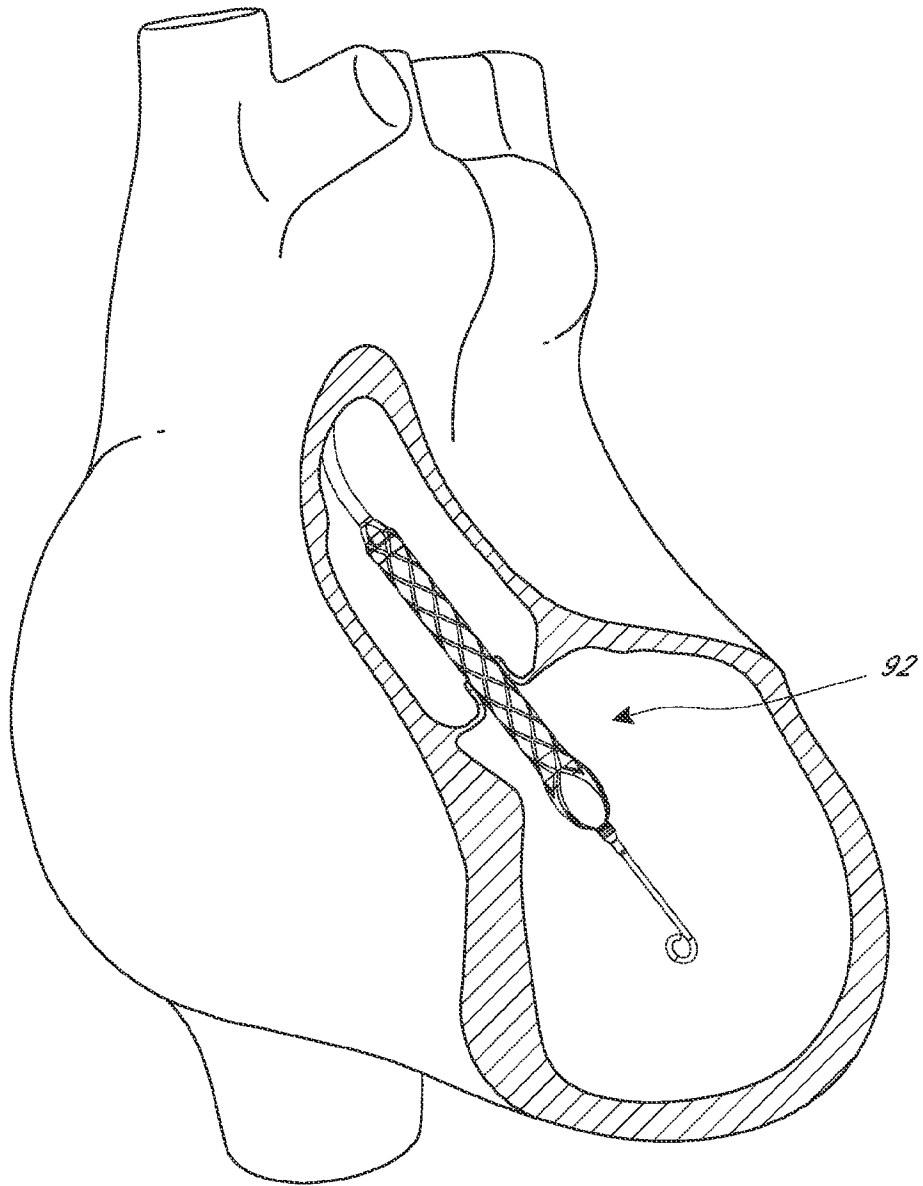
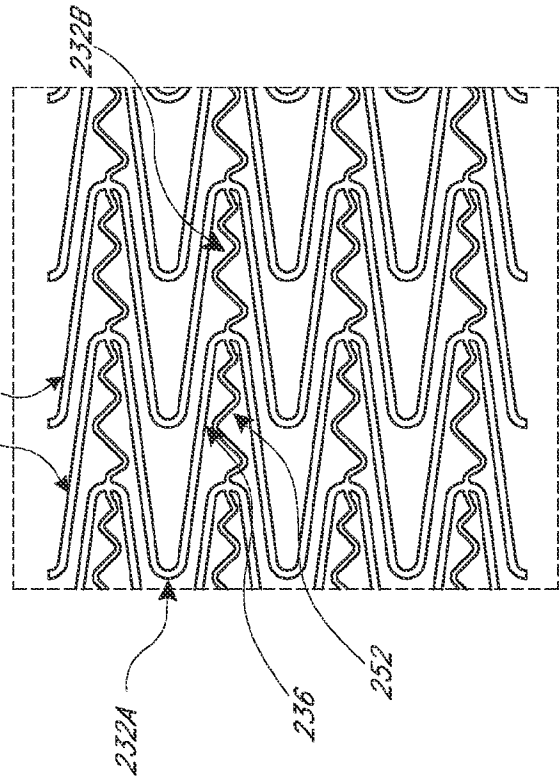
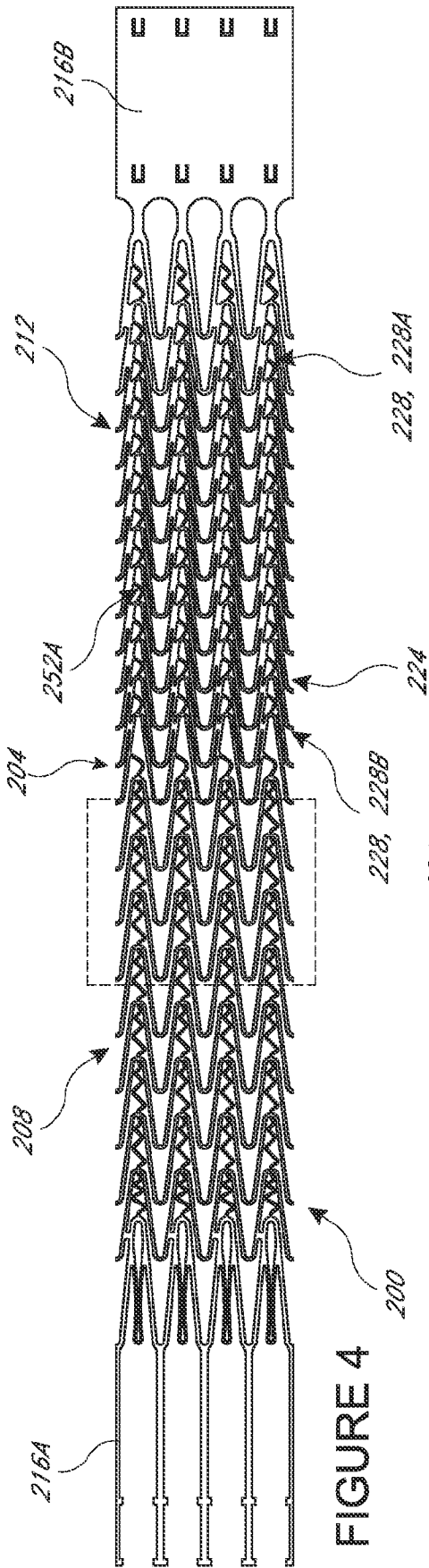

FIGURE 3



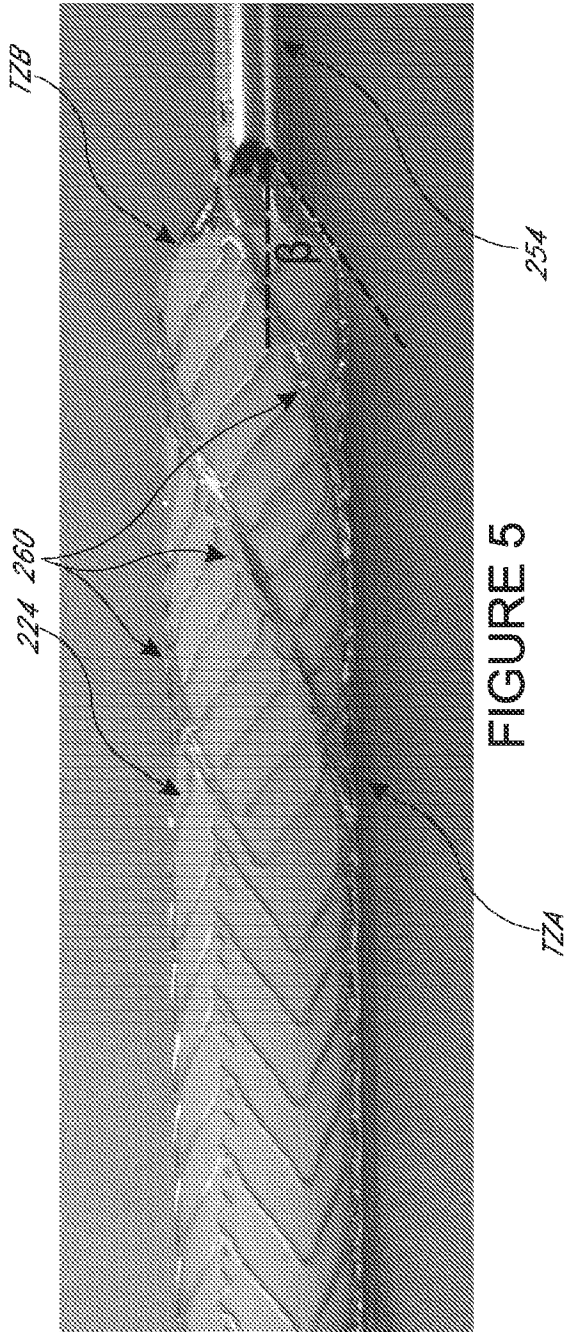

FIGURE 5

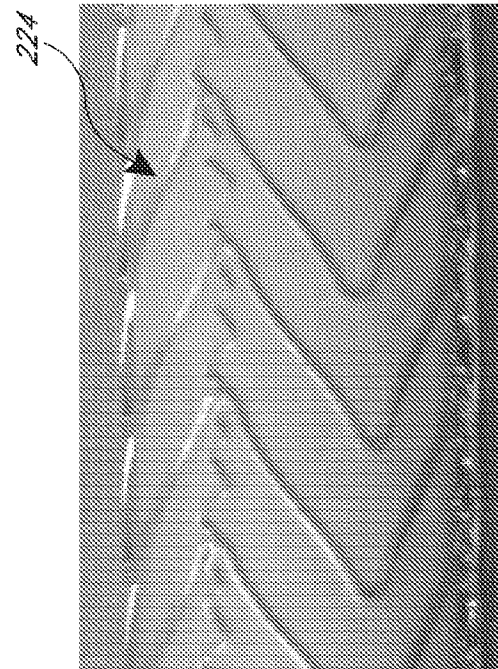

FIGURE 5A

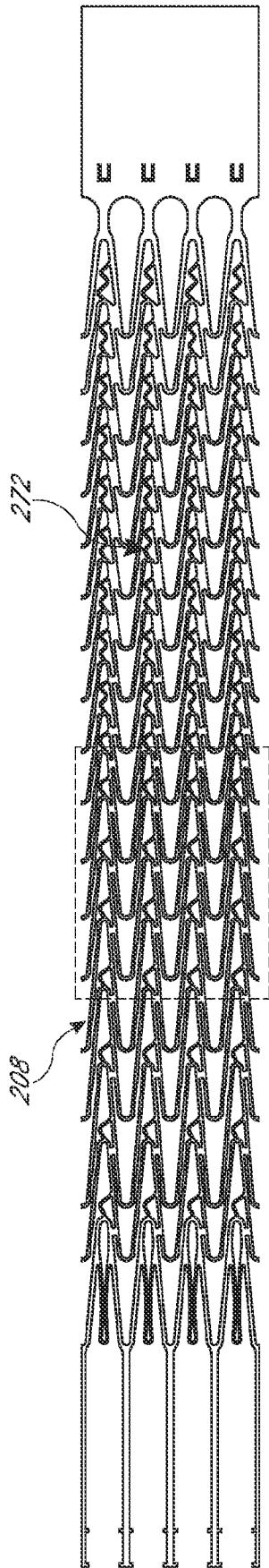

FIGURE 6

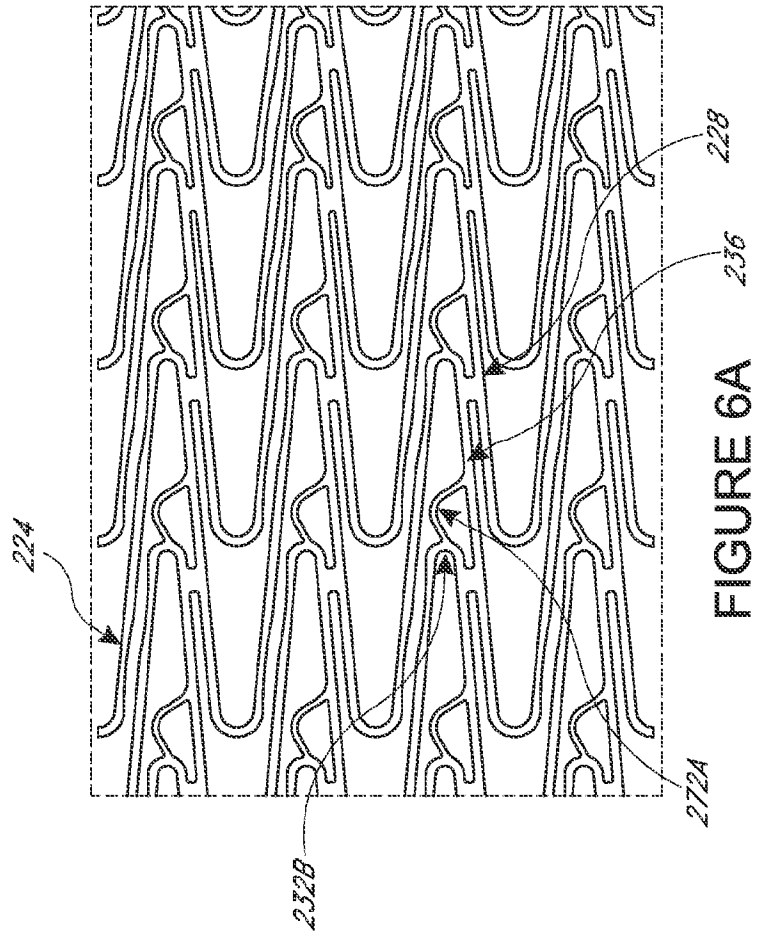

FIGURE 6A

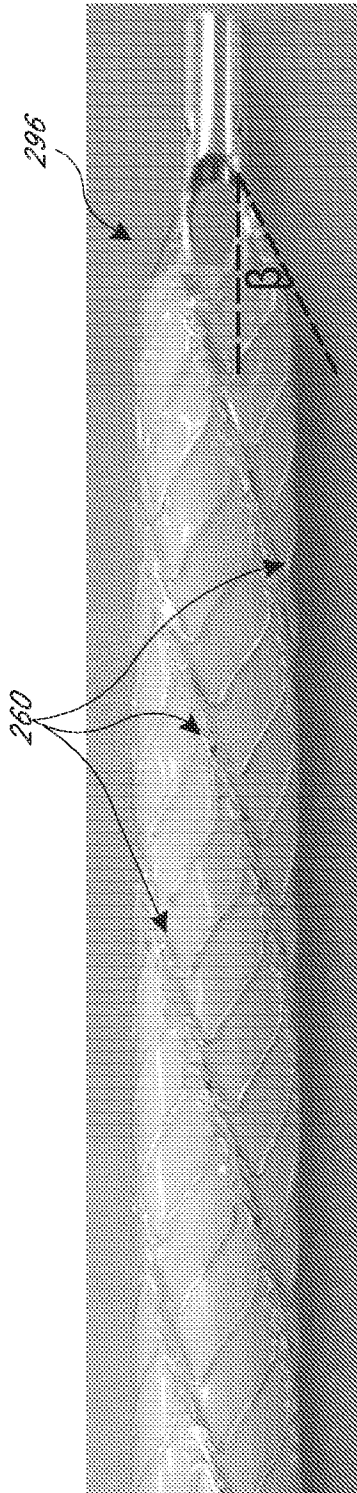

FIGURE 7

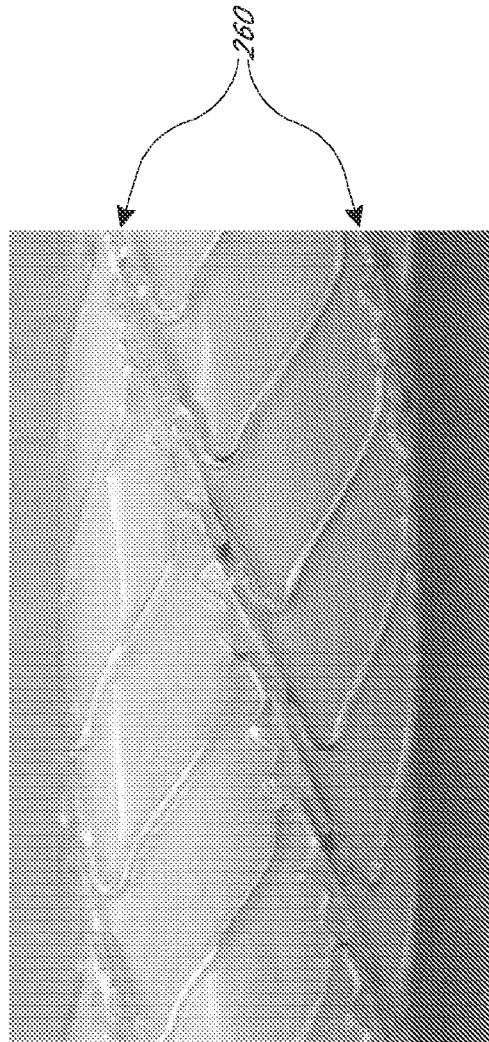

FIGURE 7A

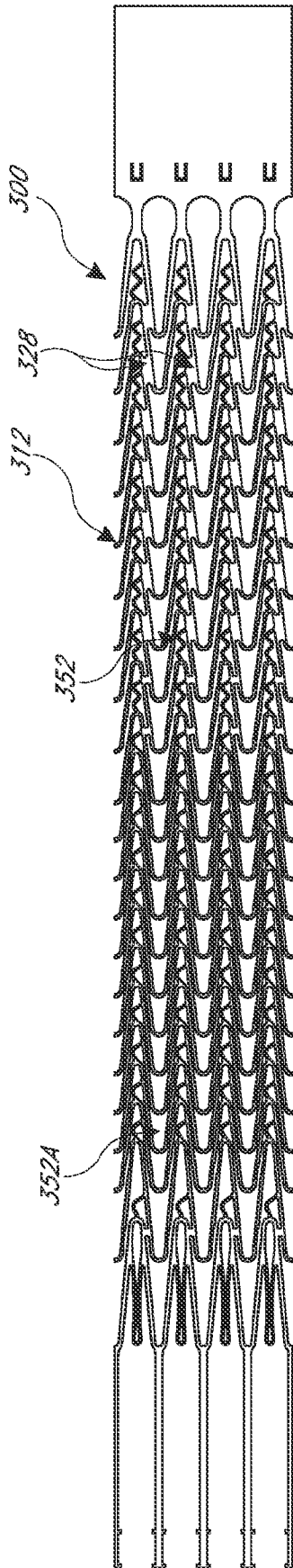

FIGURE 8

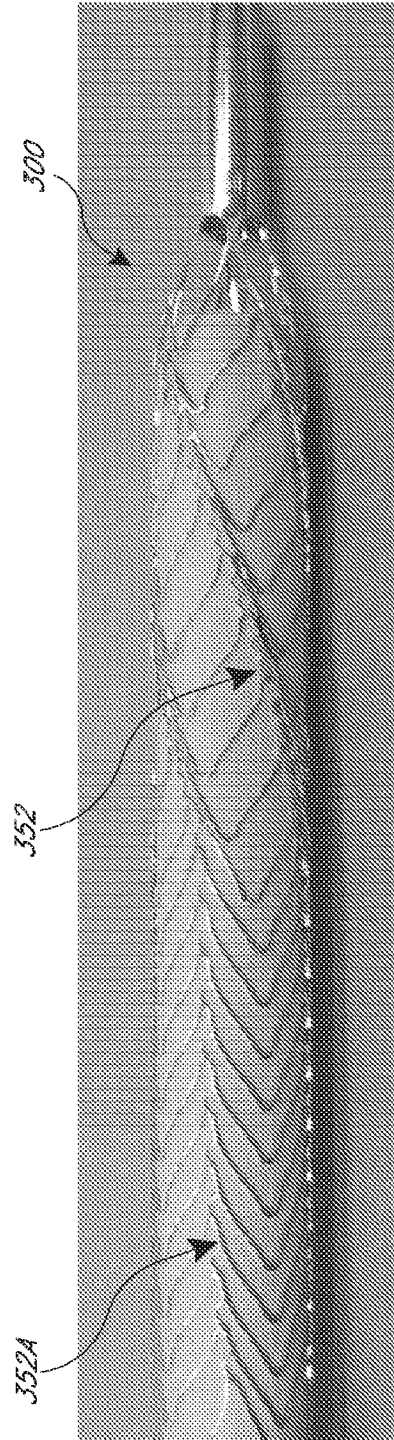
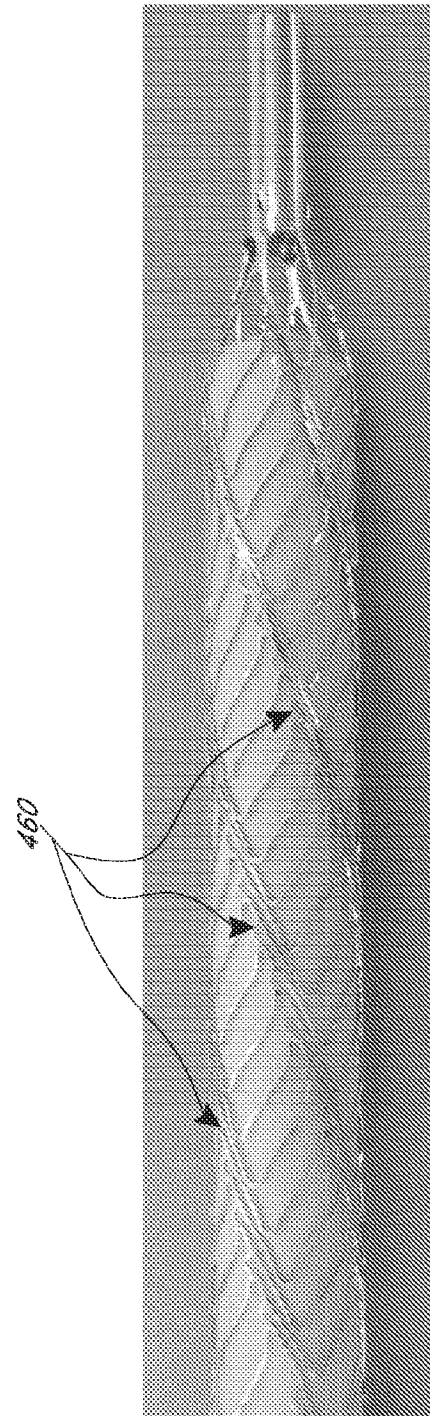
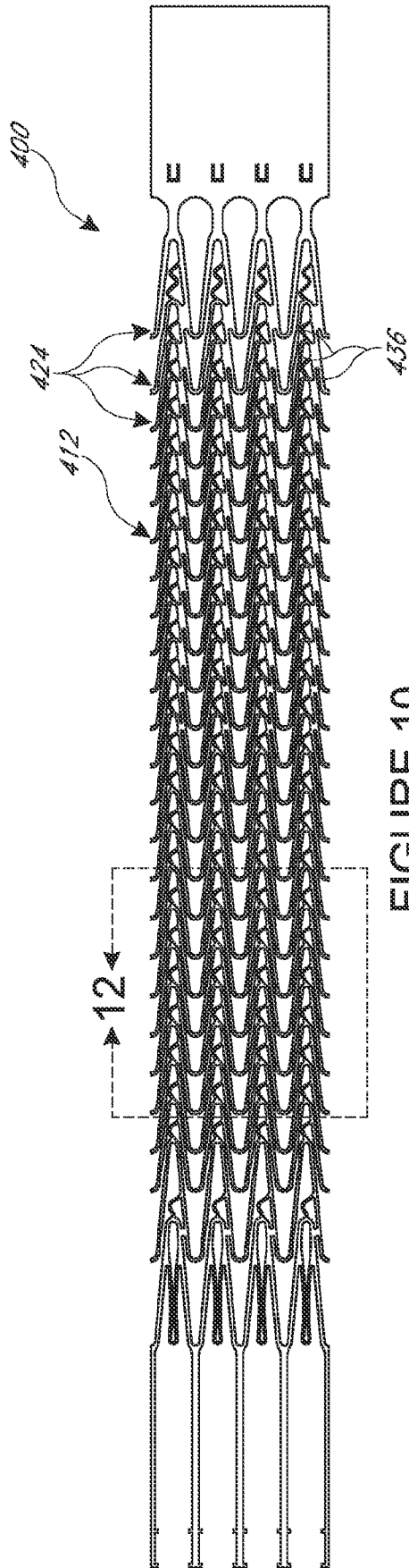

FIGURE 9



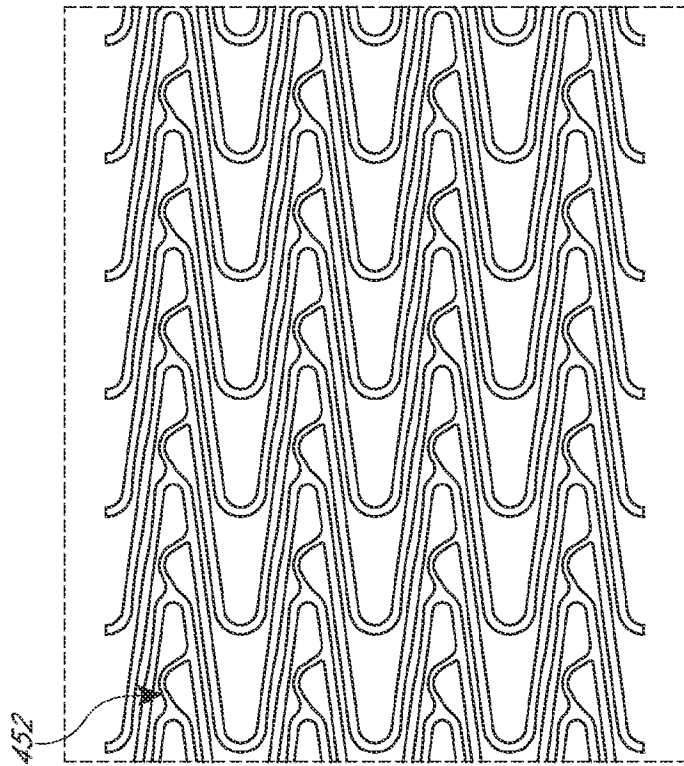

FIGURE 12

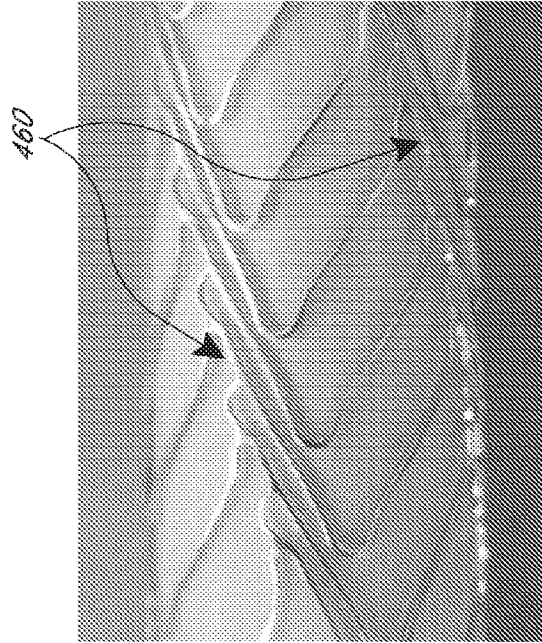

FIGURE 14

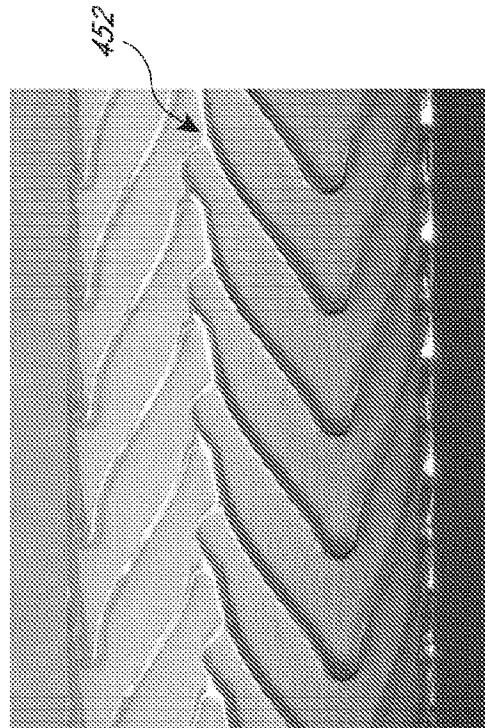

FIGURE 13

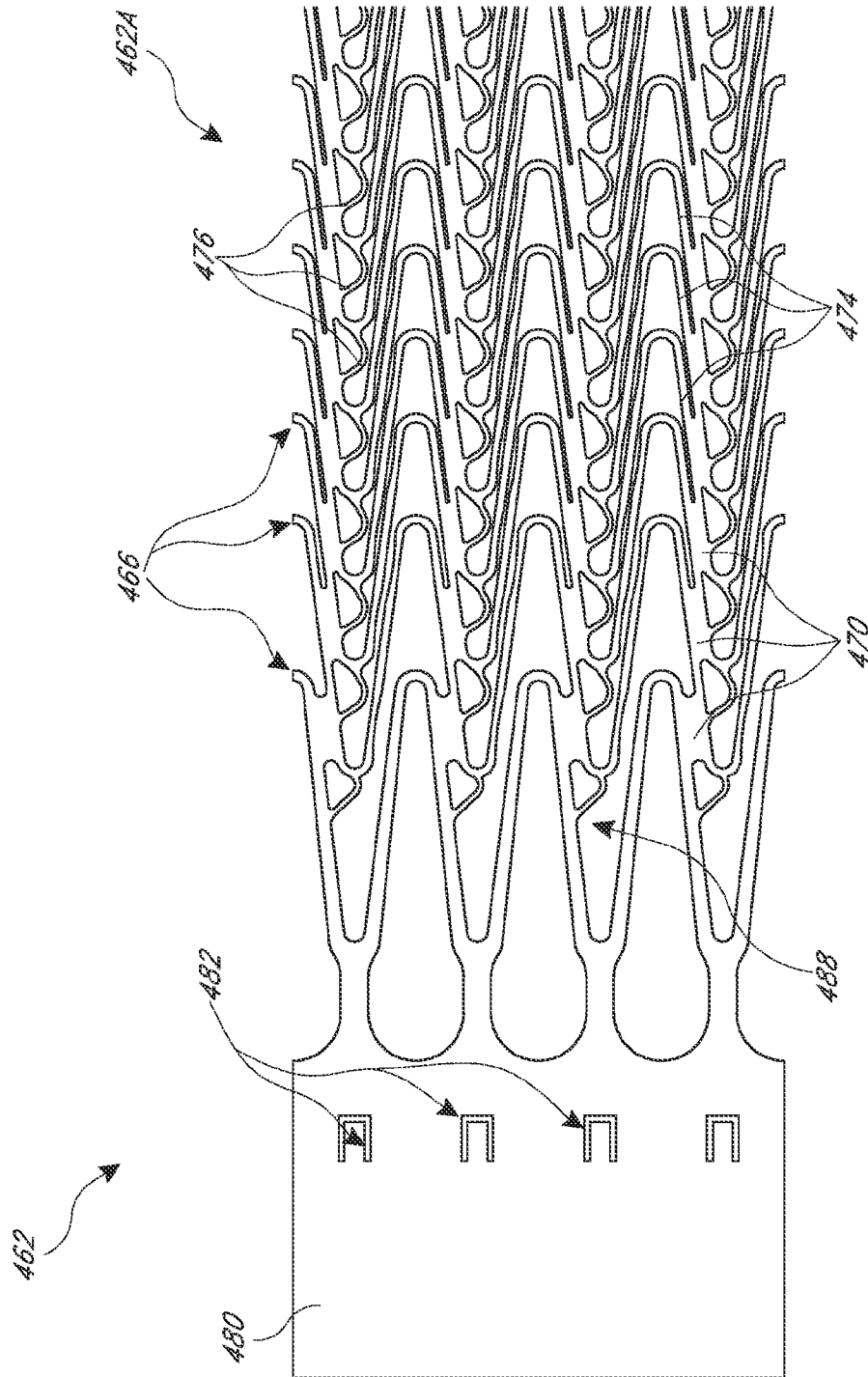

FIGURE 14A-1

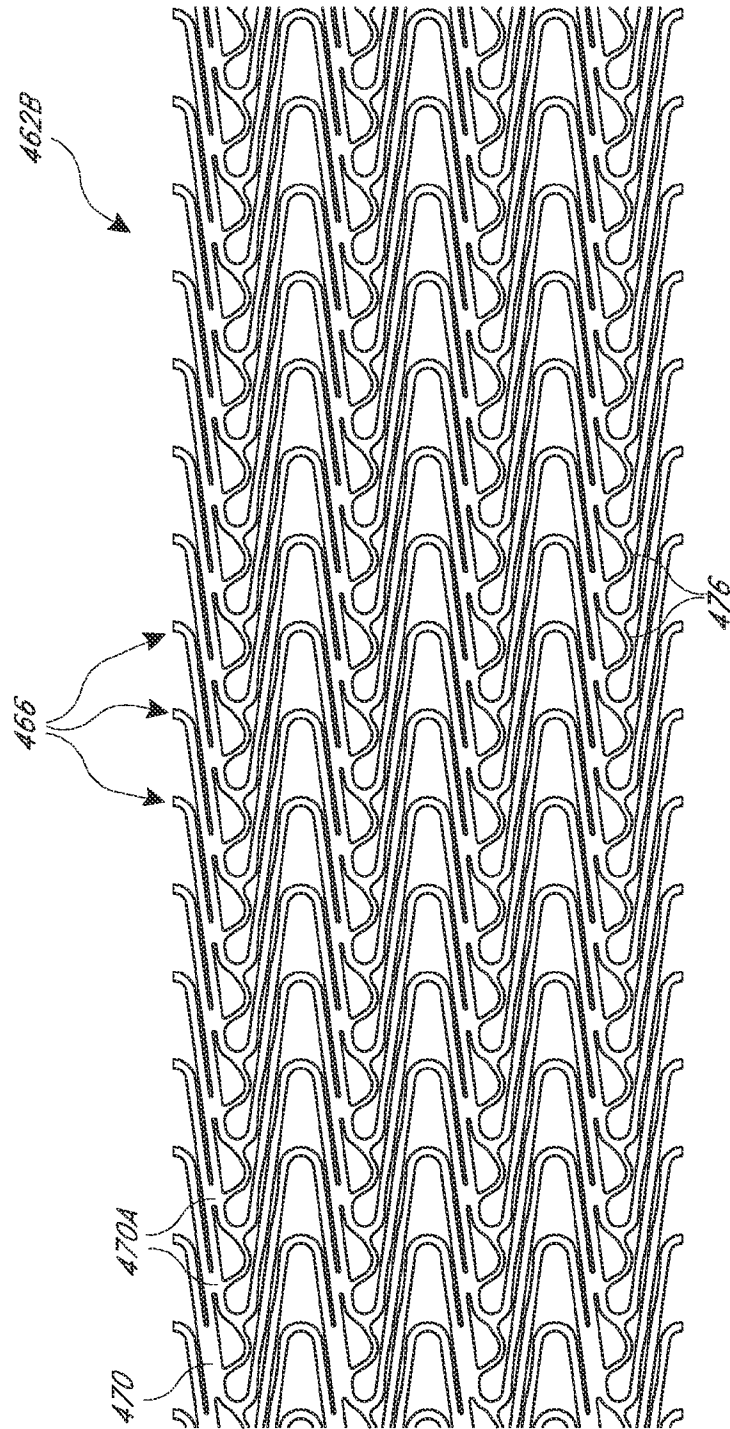

FIGURE 14A-2

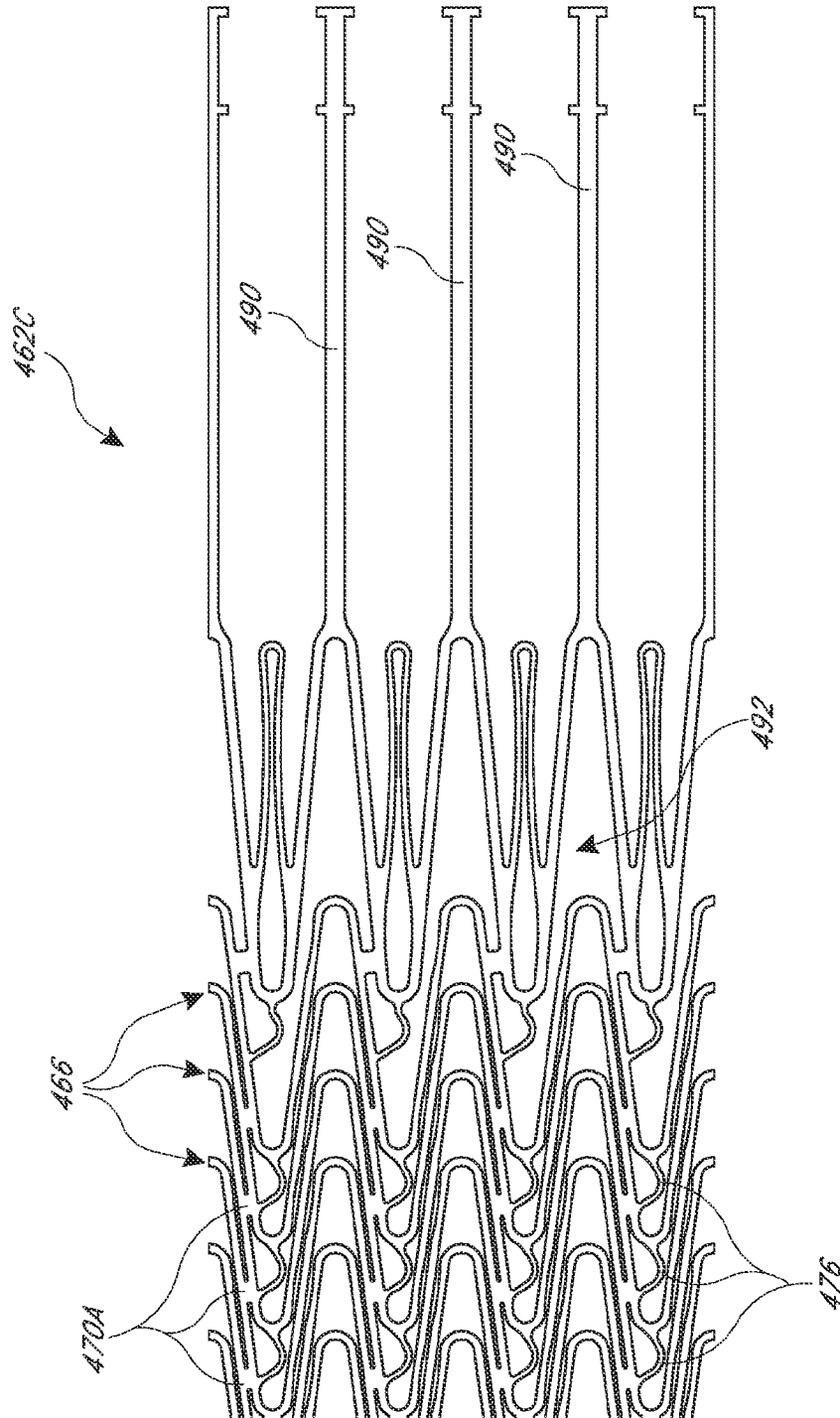

FIGURE 14A-3

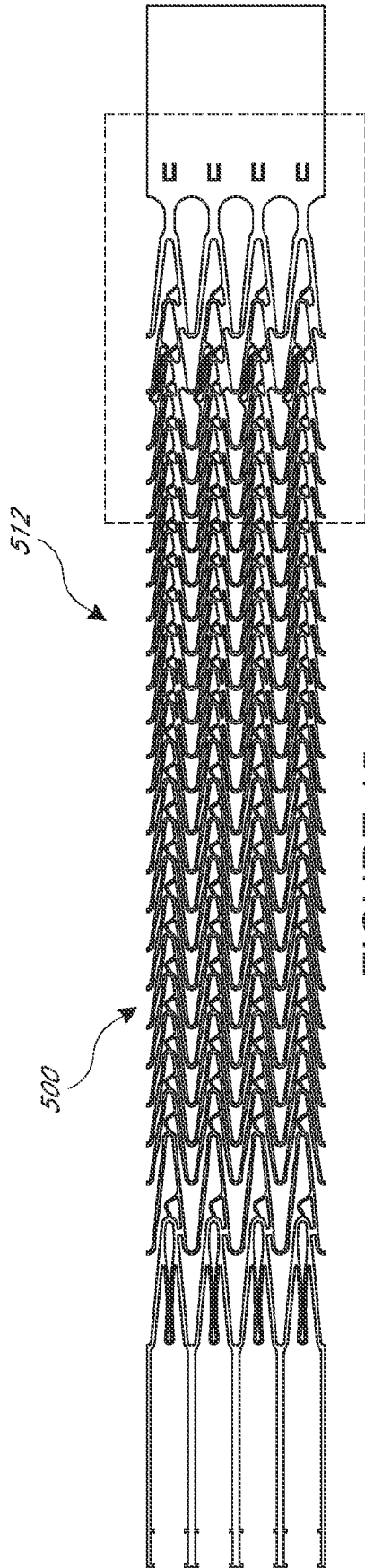

FIGURE 15

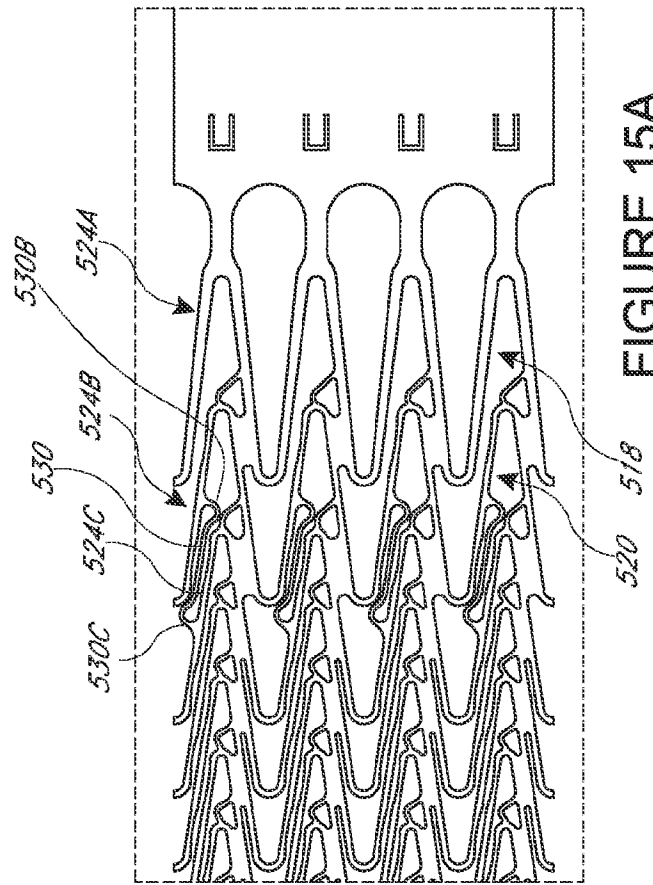

FIGURE 15A

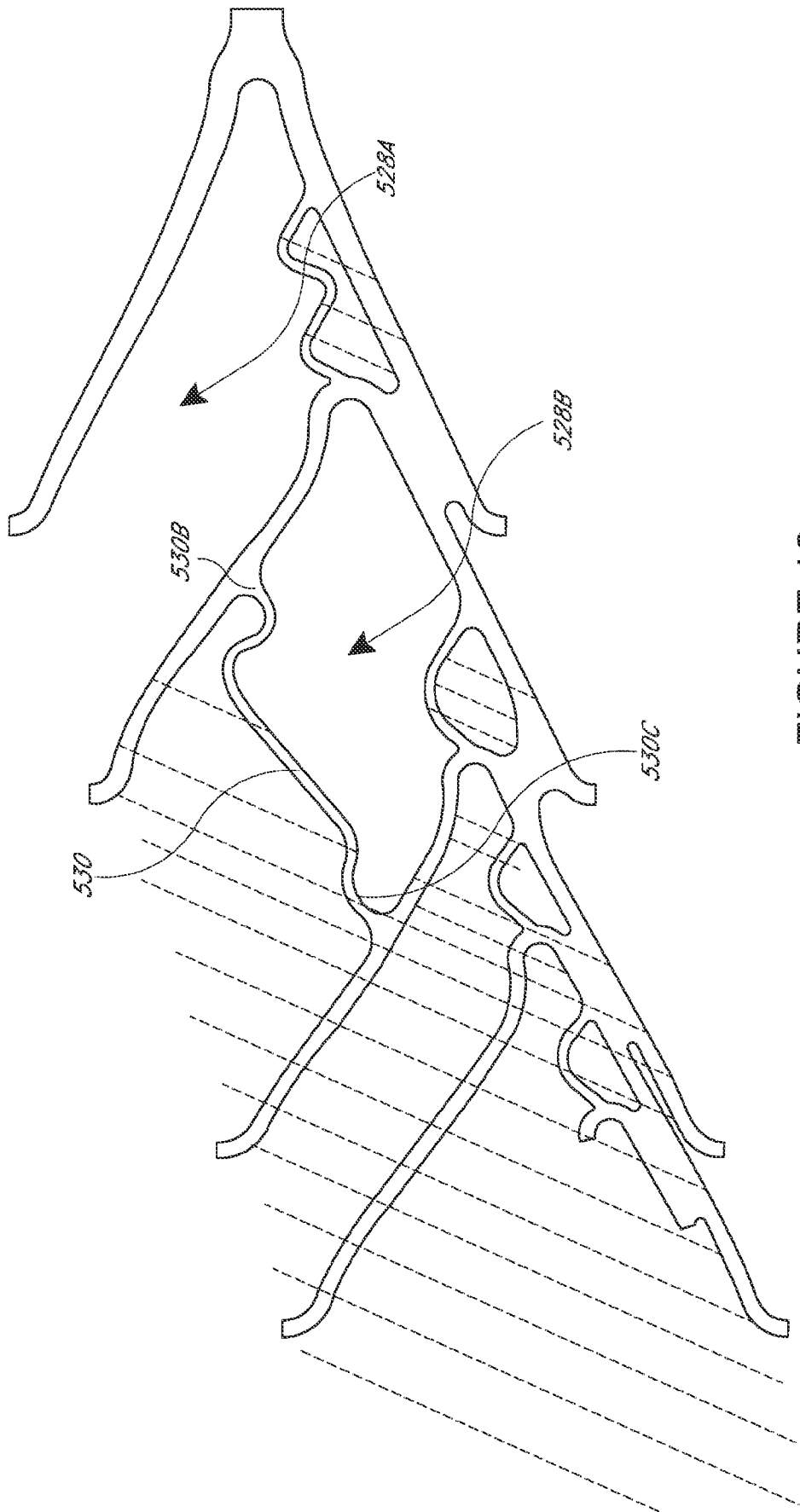

FIGURE 16

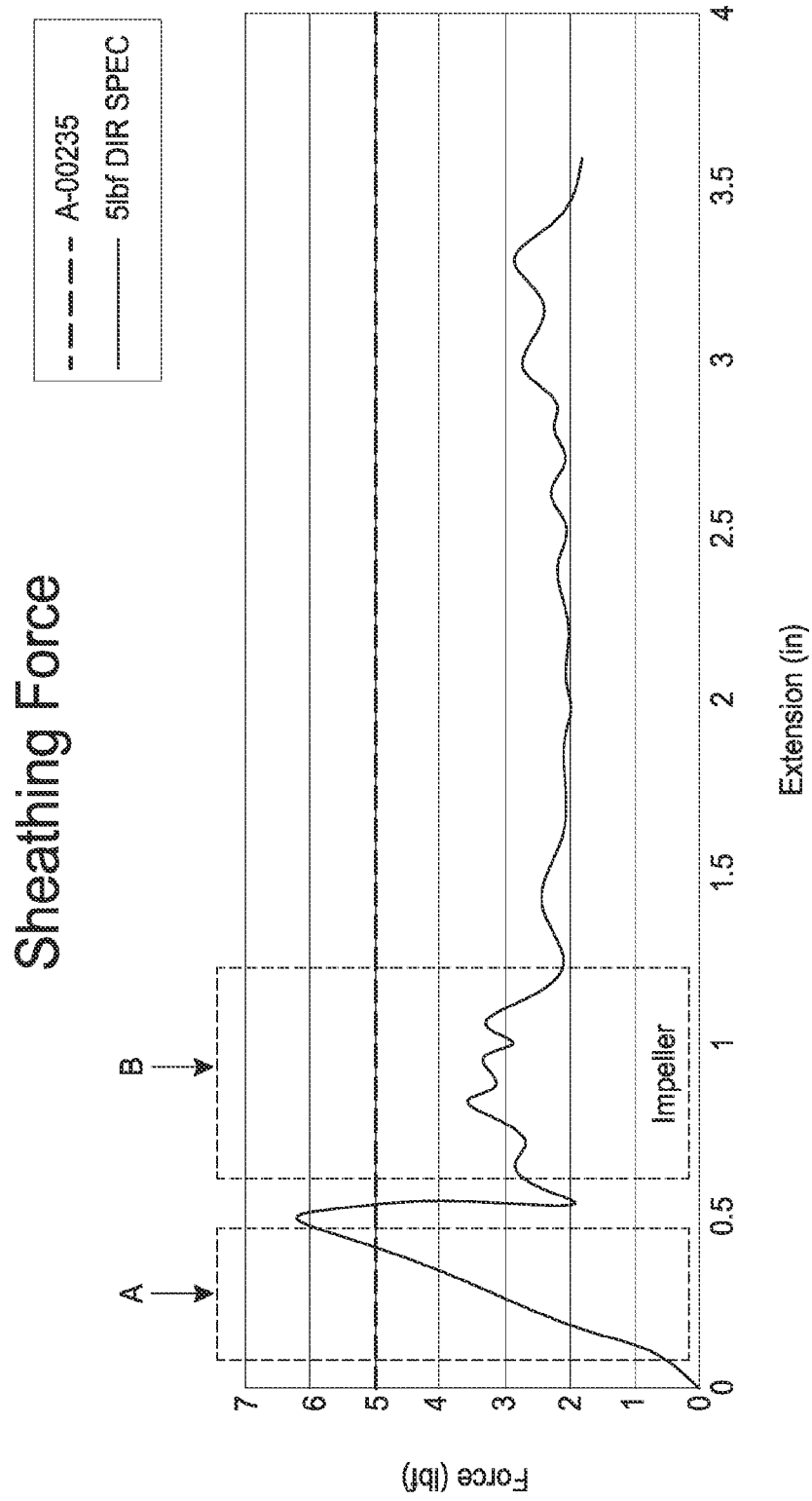



FIGURE 17

INTERNATIONAL SEARCH REPORT

International application No.
PCT/US2013/048343

A. CLASSIFICATION OF SUBJECT MATTER		
A61M 1/10(2006.01)i, A61M 25/088(2006.01)i, A61M 25/10(2006.01)i, A61M 29/00(2006.01)i		
According to International Patent Classification (IPC) or to both national classification and IPC		
B. FIELDS SEARCHED		
Minimum documentation searched (classification system followed by classification symbols) A61M 1/10; A61M 29/00; A61F 2/06; A61F 2/82; B21C 37/08; A61M 25/088; A61M 25/10		
Documentation searched other than minimum documentation to the extent that such documents are included in the fields searched Korean utility models and applications for utility models Japanese utility models and applications for utility models		
Electronic data base consulted during the international search (name of data base and, where practicable, search terms used) eKOMPASS(KIPO internal) & Keywords: catheter pump, impeller, mesh, cannula, stent, strut, connector, apex, apice, concentrate, density, stiffness		
C. DOCUMENTS CONSIDERED TO BE RELEVANT		
Category*	Citation of document, with indication, where appropriate, of the relevant passages	Relevant to claim No.
X	US 2011-0004046 A1 (CAMPBELL, R. L. et al.) 6 January 2011 See abstract; claim 10; paragraphs [0073], [0077], [0087], [0092], [0096]; figures 14A-14C, 15A-15C.	1, 3-6, 13-14, 29
A		2, 7-12, 15-28
A	WO 99-16387 A1 (GLOBAL THERAPEUTICS, INC.) 8 April 1999 See abstract; claim 1; figures 1-6.	1-29
A	US 2003-0018380 A1 (CRAIG, C. H. et al.) 23 January 2003 See abstract; claim 7; figures 2-3.	1-29
A	US 2011-0004291 A1 (DAVIS, H. R. et al.) 6 January 2011 See abstract; claim 1; figure 2A.	1-29
A	US 2008-0167679 A1 (PAPP, J. E.) 10 July 2008 See abstract; claim 1; figures 1-2.	1-29
<input type="checkbox"/> Further documents are listed in the continuation of Box C. <input checked="" type="checkbox"/> See patent family annex.		
* Special categories of cited documents: "A" document defining the general state of the art which is not considered to be of particular relevance "E" earlier application or patent but published on or after the international filing date "L" document which may throw doubts on priority claim(s) or which is cited to establish the publication date of citation or other special reason (as specified) "O" document referring to an oral disclosure, use, exhibition or other means "P" document published prior to the international filing date but later than the priority date claimed		"T" later document published after the international filing date or priority date and not in conflict with the application but cited to understand the principle or theory underlying the invention "X" document of particular relevance; the claimed invention cannot be considered novel or cannot be considered to involve an inventive step when the document is taken alone "Y" document of particular relevance; the claimed invention cannot be considered to involve an inventive step when the document is combined with one or more other such documents, such combination being obvious to a person skilled in the art "&" document member of the same patent family
Date of the actual completion of the international search 11 October 2013 (11.10.2013)		Date of mailing of the international search report 11 October 2013 (11.10.2013)
Name and mailing address of the ISA/KR  Korean Intellectual Property Office 189 Cheongsu-ro, Seo-gu, Daejeon Metropolitan City, 302-701, Republic of Korea Facsimile No. +82-42-472-7140		Authorized officer HAN In Ho Telephone No. +82-42-481-3362 

INTERNATIONAL SEARCH REPORT

Information on patent family members

International application No.

PCT/US2013/048343

Patent document cited in search report	Publication date	Patent family member(s)	Publication date
US 2011-0004046 A1	06/01/2011	AU 2010-266166 A1	23/02/2012
		CA 2769631 A1	06/01/2011
		CN 102481398 A	30/05/2012
		EP 2448613 A1	09/05/2012
		JP 2012-53197 5A	13/12/2012
		US 8535211 B2	17/09/2013
		WO 2011-003043 A1	06/01/2011
		WO 99-16387 A1	08/04/1999
AU 736981 B2	09/08/2001		
CA 2304578 A1	08/04/1999		
EP 1018986 A1	19/07/2000		
EP 1018986 B1	21/01/2004		
JP 2001-517535 A	09/10/2001		
US 6042606 A	28/03/2000		
US 6299635 B1	09/10/2001		
US 2003-0018380 A1	23/01/2003		
		AU 2002-306990 B2	05/10/2006
		CA 2442200 A1	10/10/2002
		CA 2442205 A1	10/10/2002
		EP 1372754 A1	02/01/2004
		EP 1372754 B1	13/06/2007
		EP 1404391 A1	07/04/2004
		EP 1404391 B1	27/04/2011
		JP 2004-529695 A	30/09/2004
		JP 2004-534148 A	11/11/2004
		US 2002-0144757 A1	10/10/2002
		US 2002-0193865 A1	19/12/2002
		US 2003-0077200 A1	24/04/2003
		US 2012-004718 A1	05/01/2012
		WO 02-078763 A1	10/10/2002
		WO 02-078764 A1	10/10/2002
US 2011-0004291 A1	06/01/2011	CA 2767101 A1	06/01/2011
		CN 102770094 A	07/11/2012
		EP 2448530 A1	09/05/2012
		US 2011-0004292 A1	06/01/2011
		US 8366763 B2	05/02/2013
		US 8382818 B2	26/02/2013
		WO 2011-003095 A1	06/01/2011
US 2008-0167679 A1	10/07/2008	US 2010-0049240 A1	25/02/2010