

W. Stoddard,

2 Sheets, Sheet 1.

Cutting Shingles.

N^o 8,831.

Patented Mar. 23, 1852.

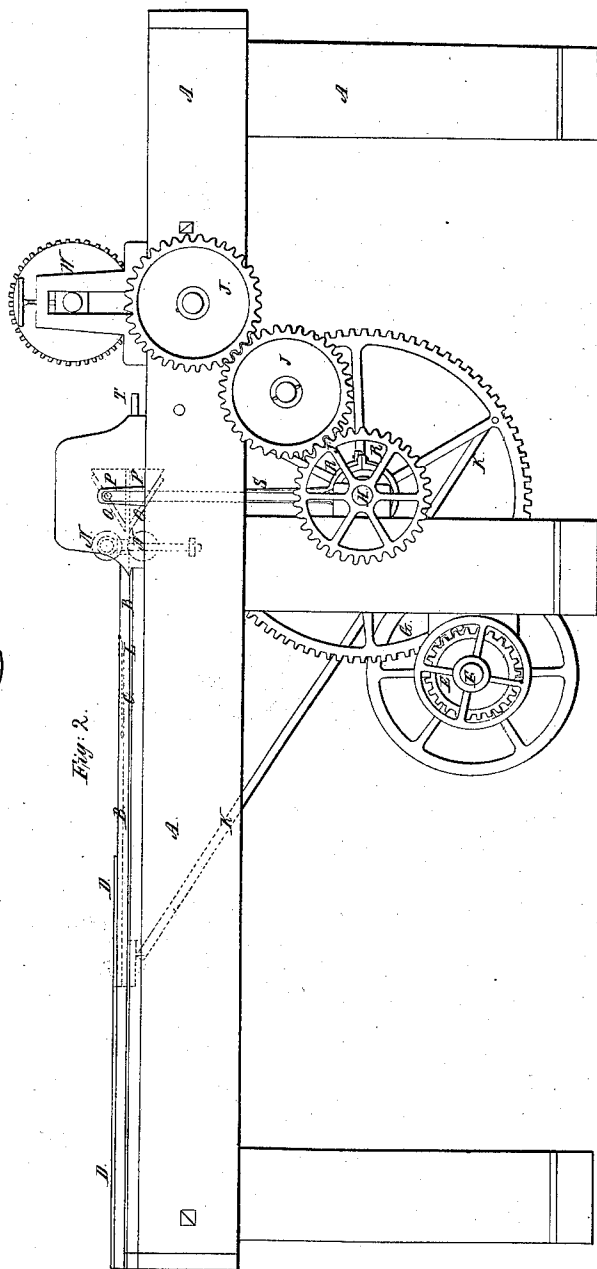
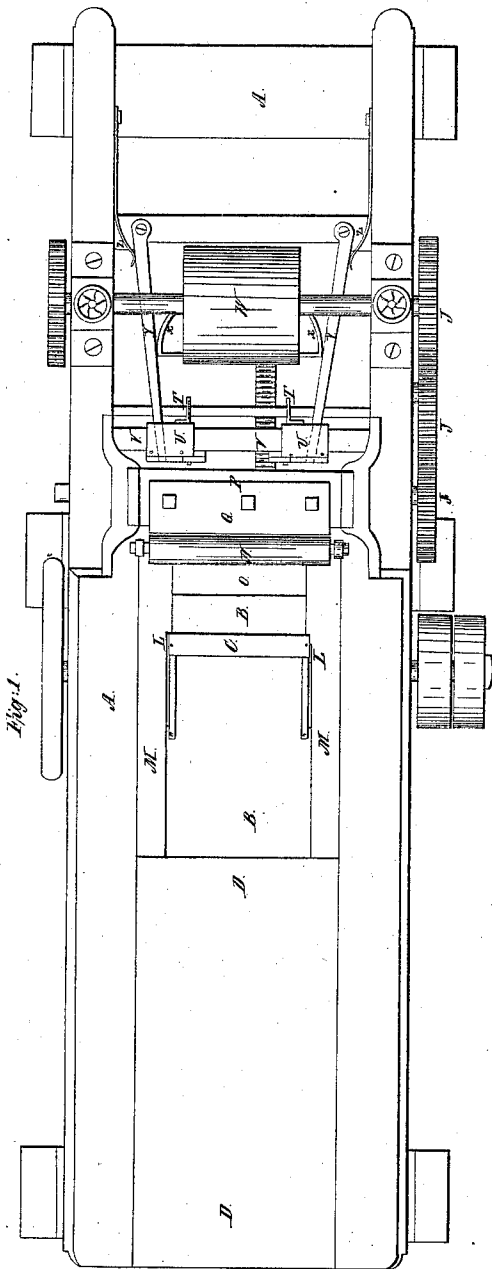

UNITED STATES PATENT OFFICE.

WM. STODDARD, OF LOWELL, MASSACHUSETTS.

MACHINE FOR JOINTING SHINGLES.

Specification of Letters Patent No. 8,831, dated March 23, 1852.

To all whom it may concern:

Be it known that I, WILLIAM STODDARD, of Lowell, in the county of Middlesex and State of Massachusetts, have invented certain new and useful Improvements in Machines for Cutting and Planing Shingles, and that the following description, taken in connection with the accompanying drawings, hereinafter referred to, forms a full and exact specification of the same, wherein I have set forth the nature and principles of my invention, by which it may be distinguished from others of a similar class, together with such parts as I claim and desire to have secured to me by Letters Patent.

The figures of the accompanying plates of drawings represent my improvements.

In Plate 1, Figure 1 is a plan of shingle machine and Fig. 2 a side elevation of the same. In Plate 2, Fig. 3 is an end view, Fig. 4 a detail view of the back side of the jointing apparatus, Fig. 5 a view of the opposite side of the same and Fig. 6 is a detail sectional view of the shaving or planing knives, guide rolls &c.

My improvements consist, first, in the arrangement by which I am enabled to point the shingle and plane or shave both sides at the same time, this effect being produced by planing knives set in plane stocks moving vertically, the operation of which will be hereinafter explained. I have also made an improvement by which the machine will cut or joint the edges of any width of shingle, the shingle itself serving to regulate the position of the jointing knives.

A A A in the several figures, represents the framework of the machine, which can be constructed as shown in the drawings or in any other suitable manner. On the top of the machine is the traversing slide B B, with the splitting knife C attached to it, and on which slide the block to be split is placed. The slide B B is made to pass forward and back under the stationary platform D D by the following arrangement of mechanical devices. The pinion E on the driving shaft F engages with the large gear wheel G placed on the shaft H. The crank or arm I on this shaft is attached to the outer edge of the wheel G by a short axle which passes through one end of the long connecting rod K K, the other end of said rod being attached to the bottom of the slide B B, as shown by dotted lines in Fig. 2, Plate 1, so that when the wheel G revolves it causes

the slide with its splitting knife to pass forward and back. The block to be split is placed upon the slide with one end against the edge of the knife C. This knife is attached to the slide by thin springs or strips of steel which allow it to fall nearly flat upon the slide when it passes under the platform D D, while it is again raised by passing over the short inclined planes or grooves L L in the guide rails M, M. When the slide passes back the knife C will split a piece from the block, said block being held firm by abutting against the end of the platform D D, and the split will fall upon the bed piece O O with the block behind it. When the slide returns the block will be placed in its former position upon the same, while the split will be forced, by the front edge of said slide or knife through the feed rollers N, N and between the vertical sliding blocks or plane stocks P, P which hold the shaving or pointing knives Q Q, shaped as shown in Fig. 6 Plate 2. Motion is imparted to these plane stocks, by which they are made to open and shut, by means of the eccentrics or cams R R, on the shaft H, one of which is connected to the upper and the other to the lower plane stock, by the arms S, S. The eccentrics are so placed that when the split first enters between the plane stocks, said stocks are open to their greatest extent, but as the split passes through, they gradually close, and the knives having the direction shown in Fig. 6, will shave or plane the shingle to a point. After the shingle has thus been pointed, it passes through to the knives T, T, set in the boxes U, U to have its edges cut off. These boxes are made to traverse forward and back on the cross bar V V, as follows.—The roll W has motion imparted to it, by means of the gears J, J and the wheel J' on the shaft H. On the side of the roll W are the bent arms or cams X, X, which bear against and press apart the arms Y, Y one end of each of which is attached to a cross bar of the machine, and the other end plays between two pins on the bottom of the boxes U, U, which are thus forced apart. These boxes are made to approach each other again, by the bent springs Z, Z pressing against the arms Y, Y. The cams X, X are so placed that the knife boxes will be approaching each other, (being forced together by the springs Z, Z) just as the shingle passes from the planing knives, so that the cams *a, a*, Figs.

4 and 5, Plate 2, turning on a pivot on the side of the boxes U, U will strike against the edges of the shingle. The cam *a*, of each knife box is connected, by a short arm *b*, to a pawl *c* turning on a pivot *d*, said pawl engaging with the teeth of the rack *e* on the bottom of the bar V V. When the cam *a* strikes against the edge of the shingle, it will, through the medium of the arm *b*, bring the pawl against the rack *e*, being held there by the bent spring *f* pressing against said cam, thus holding the box and consequently the knife, firmly while the edges of the shingle are being cut, the shingle itself serving as a gage to set the position of the knife. When the shingle is thus finished the cams X, X bear against the arms Y, Y the ends of which, playing between the pins on the bottom of the boxes U, U strike against the curved ends of the pawls *c*, *c* which are thus disengaged from

the rack, allowing the boxes U, U to be forced apart from each other as before, when they again return and are again set to cut the next shingle. 25

Having thus described my improvements in shingle machines, I shall state my claims as follows.

What I claim as my invention and desire to have secured to me by Letters Patent is, 30

The arrangement of the horizontal sliding boxes which carry the jointing knives, by which they will cut the edges of any width of shingle, the shingle itself operating the devices for holding the boxes firmly 35 and in the proper position while the shingle is being cut, as herein above set forth.

WILLIAM STODDARD.

Witnesses:

BENJ. C. PIPER,
EZRA LINCOLN.