

No. 652,496.

Patented June 26, 1900.

H. VAN SICKLE.
BROODER HEATER.

(Application filed July 22, 1899.)

(No Model.)

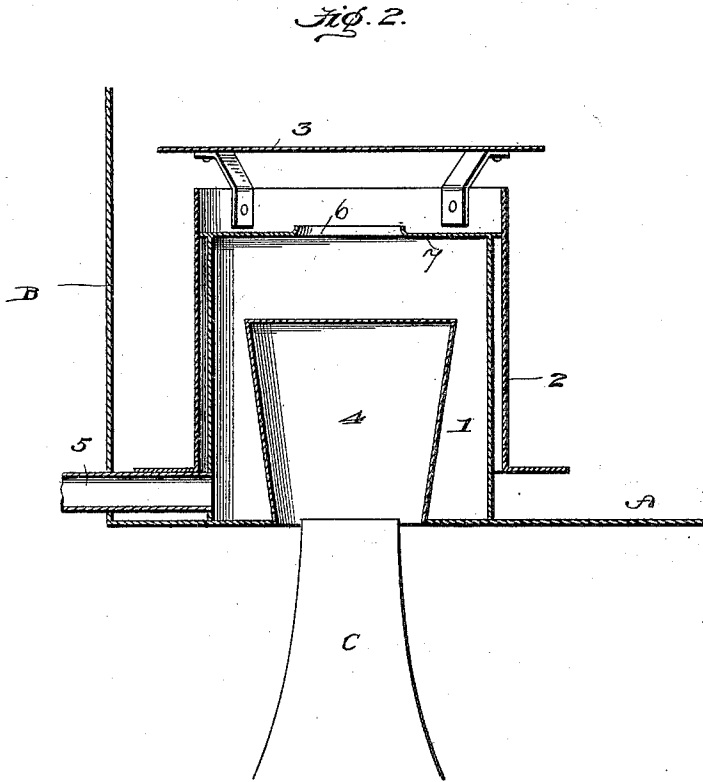
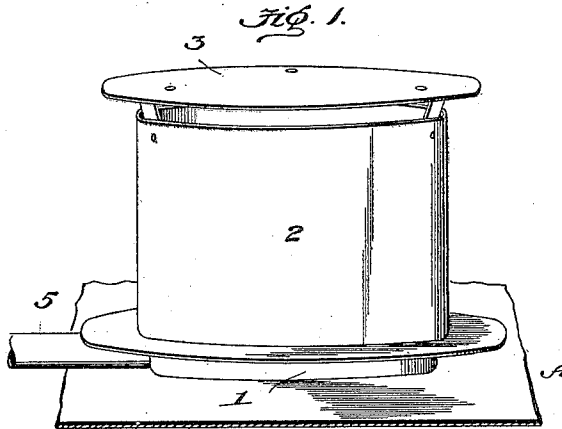

Inventor
Howard Van Sickle
by
A. B. Wilson
Attorneys

Witnesses
Wm. C. Shier
C. Wilson

UNITED STATES PATENT OFFICE.

HOWARD VAN SICKLE, OF LEBANON, NEW JERSEY.

BROODER-HEATER.

SPECIFICATION forming part of Letters Patent No. 652,496, dated June 26, 1900.

Application filed July 22, 1899. Serial No. 724,801. (No model.)

To all whom it may concern:

Be it known that I, HOWARD VAN SICKLE, a citizen of the United States, residing at Lebanon, in the county of Hunterdon and State of New Jersey, have invented certain new and useful Improvements in Brooder-Heaters; and I do declare the following to be a full, clear, and exact description of the invention, such as will enable others skilled in the art to which it appertains to make and use the same.

The invention relates to improvements in heaters for hot-air brooders; and the object is to provide the brooder with a warm fresh current of air and distribute the same evenly throughout the brooder, so as to maintain it at an equable temperature at all times.

To this end the invention consists in the construction, combination, and arrangement of the several elements of the same, as will be hereinafter fully described, and particularly pointed out in the appended claim.

In the accompanying drawings, Figure 1 is a perspective view of my improved heater for hot-air brooders. Fig. 2 is a vertical central section of the same.

In the drawings the same reference characters indicate the same parts of the invention.

A denotes the floor, and B the end wall, of the brooder.

C denotes the top of the lamp-chimney, and 1 denotes the heater-drum, extending through an opening in the bottom of the brooder a short distance inside and provided with a central opening 6 in its top plate 7.

2 denotes the heater-dome, which surrounds the upper end of the heater-drum, and it is provided with a raised top 3 to permit the heated air from the drum to be evenly diffused in all directions in the heater.

The heater-dome 2, while it forms the support for the raised top 3, which serves as a deflector, also partially surrounds the heater-drum 1 and forms in conjunction therewith a dead-air space between a portion of its height and a portion of the height of the heater-drum 1, which space contains and retains heated dead air, which prolongs the heating capacity of the heater-drum 1, as the heat from the dead air cannot escape except by radiation and is therefore maintained during the direct application of the heat and cools

only gradually after the lamp has been extinguished, thereby obviating sudden changes in the temperature to which the brooder-heater is subjected.

4 denotes an inverted-cone-shaped hood concentrically fixed within the heater-drum immediately over the lamp-chimney, and 5 denotes the fresh-air flue, leading from the outside of the brooder into the heater-drum.

The operation is as follows: The heat from the lamp rises in the inverted-cone-shaped hood, which heats the air in the drum, which rises into the dome 2 and passes outward into the brooder through the space below the top 3, the fresh air from the outside in the meanwhile passing into the heater through the flue 5.

It will of course be understood that various changes in the form, proportion, and the minor details of construction may be resorted to without departing from the principle or sacrificing any of the advantages of this invention.

Having thus described the invention, what is claimed, and desired to be secured by Letters Patent, is—

In a brooder-heater, the combination of the brooder-floor provided with a centrally-disposed orifice for the admission of heated air, the inverted-cone-shaped hood fixed concentrically within the heater-drum and encompassing said centrally-disposed admission-orifice and extending upwardly from said brooder-floor, the heater-drum 1 encompassing the inverted-cone-shaped hood and provided with a centrally-disposed orifice 6 in its top plate 7, the heater-dome surrounding said heater-drum and forming a heat-retaining dead-air space therebetween and provided with the raised heat-deflecting top 3, and the fresh-air flue 5 leading from the outside of the brooder-heater into said heater-drum, substantially as and for the purpose set forth.

In testimony whereof I have hereunto set my hand in presence of two subscribing witnesses.

HOWARD VAN SICKLE.

Witnesses:

SAML. L. VOORHEES,
C. A. VOORHEES.