



Europäisches Patentamt  
European Patent Office  
Office européen des brevets



(11) **EP 1 121 890 A2**

(12) **EUROPEAN PATENT APPLICATION**

(43) Date of publication:  
**08.08.2001 Bulletin 2001/32**

(51) Int Cl.7: **A47L 9/24**

(21) Application number: **01101653.2**

(22) Date of filing: **26.01.2001**

(84) Designated Contracting States:  
**AT BE CH CY DE DK ES FI FR GB GR IE IT LI LU  
MC NL PT SE TR**  
Designated Extension States:  
**AL LT LV MK RO SI**

(72) Inventor: **Amoretti, Luigi**  
**36065 Mussolente (Vicenza) (IT)**

(74) Representative: **Modiano, Guido, Dr.-Ing. et al**  
**Modiano & Associati SpA**  
**Via Meravigli, 16**  
**20123 Milano (IT)**

(30) Priority: **01.02.2000 IT PD000029**

(71) Applicant: **T.P.A. IMPEX S.p.A.**  
**I-36060 Romano d'Ezzelino, Vicenza (IT)**

(54) **Control device, particularly for cleaning appliances**

(57) A control device, particularly for appliances used in the field of domestic and/or industrial cleaning, comprising at least one radio-wave transmitter (15)

which is located on the handle (13) of the tool of the cleaning appliance and a receiver (16) which is located on the appliance body (11) and is connected to means for controlling the various functions of the appliance.

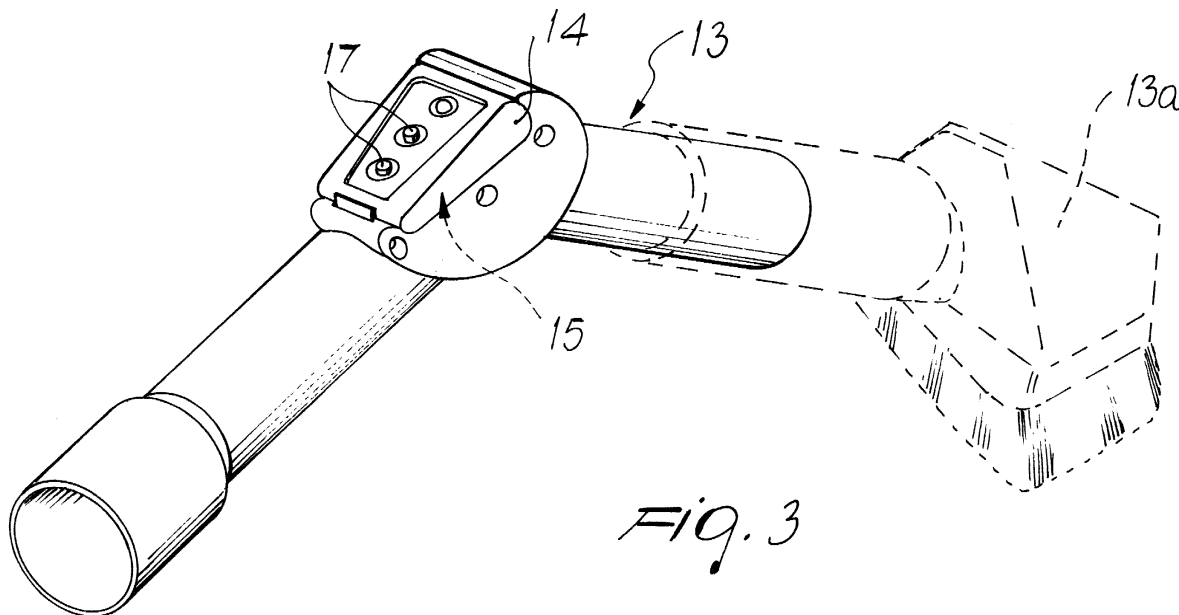

EP 1 121 890 A2

## Description

[0001] The present invention relates to a control device, particularly but not exclusively useful for appliances used in the field of domestic and/or industrial cleaning.

[0002] A wide variety of models of cleaning appliance is currently commercially available, ranging from vacuum cleaners to steam cleaners, irons, combined appliances and others used for cleaning in the home and in public places, such as restaurants, industries, shopping centers, et cetera.

[0003] As regards in particular steam-using appliances, there are various basic construction types which can be distinguished substantially according to the manner in which steam delivery and other components adapted to perform various auxiliary functions are controlled.

[0004] A first construction type provides for a body of the appliance which accommodates the boiler and is extended, for steam dispensing, by means of a hose which ends, at its free end, with a handle which is adapted to control the movement of the possibly replaceable tool of the steam appliance.

[0005] In this first construction type, switches are accommodated at the handle and, by means of electrical connecting wires arranged inside the hose, are connected to an electric valve which in turn controls the flow of steam or other auxiliary functions.

[0006] The connection between the switches and the electric valve occurs substantially at the mains voltage (220 and 110 V) and therefore with considerable danger for the user.

[0007] In order to minimize this danger, the switches must be appropriately insulated, and this requires a considerable expenditure of material and a considerable increase in constructive complexity and manufacturing times.

[0008] Accordingly, this first construction type, besides still not ensuring perfect safety of the controls available to the user, leads to high manufacturing costs.

[0009] A second construction type meant to obviate the drawbacks noted as regards the first construction type again provides for switches which are accommodated in the handle of the tool, but said switches are connected at low voltage (12-18 V) with an electronic board or simply with a transformer, accommodated inside the body of the appliance.

[0010] Although this second solution drastically reduces the risks entailed by the passage of current proximate to the user grip regions, it does not solve the problem of costs.

[0011] While on the one hand the user is better protected (but may still run the risk of low-voltage shocks, which are not dangerous but highly unpleasant), on the other hand the need to use an electronic board or a transformer entails an increase in costs which can be even greater than the above-cited protections on the buttons.

[0012] A third recent type accommodates, inside the handle, a wheel which controls a cable which slides within a sheath which is in turn accommodated inside the steam connection hose.

[0013] The cable reaches inside the body of the appliance, in which it controls the opening or closure of an electric valve.

[0014] Although this third construction type obviates the problem of safety due to the circulation of electric current proximate to the handle, it has characteristics of poor reliability under prolonged and intense use; moreover, experience in the field has shown that it is awkward for the user.

[0015] Another construction type provides for a pneumatic connection between a control located in the handle and a transducer located in the appliance body and preset to control the various functions thereof.

[0016] However, this type has proved itself particularly difficult to adjust and in any case still has connections (the tubes for the passage of the pressure pulses) between the handle and the appliance.

[0017] Cleaning appliances, particularly vacuum cleaners, have been recently devised which use an infrared remote control located in the handle and a receiver located in the appliance body.

[0018] Nonetheless, these appliances have shown considerable shortcomings, due mainly to the fact that usually, in use, the body of the user is interposed between the handle and the appliance body and therefore the signals sent by the remote control are not received appropriately by the receiver, and this causes severe inconvenience for the user.

[0019] The aim of the present invention is to provide a control device, particularly for appliances used in the field of cleaning, which solves the above-noted drawbacks of conventional devices, particularly obviating completely the problem of user safety.

[0020] Within this aim, an object of the present invention is to provide a control device which is constructively simple and adaptable to the various models of appliance currently provided for specific uses.

[0021] Another object of the present invention is to provide a control device which can be operated easily and ergonomically by the user.

[0022] Another object of the present invention is to provide a control device which leads to production costs and times which are competitive with respect to conventional devices.

[0023] Another object of the present invention is to provide a control device which can be manufactured with known technologies.

[0024] This aim and these and other objects which will become better apparent hereinafter are achieved by a control device, particularly for appliances used in the field of domestic and/or industrial cleaning, characterized in that it comprises at least one radio-wave transmitter which is located on the handle of the tool of the cleaning appliance and a receiver which is located on

the appliance body and is connected to means for controlling the various functions of the appliance.

**[0025]** Advantageously, the transmitter on the handle can be combined with a receiver and the receiver on the appliance body can be combined with a transmitter.

**[0026]** Further characteristics and advantages of the present invention will become better apparent from the description of an embodiment thereof, illustrated only by way of non-limitative example in the accompanying drawings, wherein:

Figure 1 is a perspective view of a cleaning appliance provided with the device according to the invention;

Figure 2 is a partially cutout side view of the machine of Figure 1;

Figure 3 is an enlarged-scale perspective view of a detail of the device according to the invention;

Figure 4 is a block diagram of the transmitter located on the handle;

Figure 5 is a block diagram of the receiver installed on board the appliance;

Figure 6 is a perspective view of an iron which can be applied to the appliance, with a handle provided with the device according to the invention.

**[0027]** With particular reference to the figures, a control device, particularly for appliances used in the field of domestic and/or industrial cleaning, according to the invention, is in this case part of an appliance such as a vacuum cleaner, generally designated by the reference numeral 10 and provided with a body 11 which accommodates per se known suction means, not shown for the sake of simplicity, and to which a flexible hose 12 for the passage of the aspirated air is connected, in this case detachably; a handle 13 is fixed, likewise detachably, to the free end of the hose, and working tools, generally designated by the reference numeral 13a, can be connected to the handle.

**[0028]** The control device comprises a radio-wave transmitter 15 which is located on the handle 13 and a receiver 16 which is arranged on the appliance body 11 and is connected to the means for controlling the various functions of said appliance, for example control switches 11a, timers, power regulators, et cetera.

**[0029]** For this purpose, the transmitter can be associated with various buttons 17, each for a specific function.

**[0030]** The transmitter 15 is arranged inside a box-like body 14 and is integrated in a board 19 which comprises a removable power supply battery 18, a microprocessor 20, one or more keys 17 and LEDs 21.

**[0031]** The receiver 16 is instead integrated in a board 22 with a microprocessor 23 and a memory 24.

**[0032]** As soon as the power supply battery 18 is inserted, the microprocessor 20 runs an algorithm and randomly assigns itself any one of a plurality of preset codes for being recognized by the appliance; this code

remains active until the battery 18 is removed or becomes drained.

**[0033]** When the appliance is switched on, for example by keeping pressed for a certain time a corresponding button which is not shown, the board 22 installed in the appliance presets itself to recognize any one of the provided radio controls that is activated within a certain time period (for example a few tens of seconds).

**[0034]** The transmitter 15 is activated by pressing one of the control buttons 17, and the appliance stores, by means of the memory 24, the identification code sent by the transmitter 15 that has activated and stores it in memory until the tuning operation is performed again (this also occurs if the machine is switched off or disconnected from the power supply).

**[0035]** Once the appliance has been tuned to the particular transmitter 15, it becomes highly unlikely for a different transmitter 15 to interact with it; it is instead possible to replace the transmitter 15 with another one at any time, since it is sufficient to perform a new tuning operation.

**[0036]** Tuning is necessary whenever the battery 18 is removed from the board 19.

**[0037]** In this manner, in order to operate the appliance it is necessary to insert the battery 18, which is supplied separately, and encode the signal.

**[0038]** Accordingly, it is certain that the appliance can be operated prior to sale and therefore that encoding must be performed directly by the user and that nearby users using identical appliances are not mutually affected by the signals.

**[0039]** It is possible to provide an embodiment in which a transceiver is provided both on the handle 13 and on board the appliance.

**[0040]** The automatic recognition function remains the same, but every time there is a status variation the appliance transmits to the radio control the new operating mode.

**[0041]** It is therefore possible to display on the handle 13 the status of the appliance (by means of LEDs, displays, optical fibers, et cetera) and know at all times, even from a distance, what the appliance is doing.

**[0042]** This can be particularly convenient for using the machine to purify or sanitize spaces or as a hydro-massage unit by connecting the delivery of the fan with a bathtub (the absence of electrical connections allows to adjust the functions in complete safety).

**[0043]** In practice it has been observed that the intended aim and objects have been achieved; in particular, it should be noted that the device according to the invention fully solves the problem of user safety while ensuring easy use and structural strength.

**[0044]** Moreover, the use of radio waves eliminates the drawbacks noted in appliances with infrared controls.

**[0045]** Moreover, the constructive simplicity of the invention and its structural adaptability to appliances intended for various services make it economically and

constructively competitive with respect to conventional devices.

**[0046]** Attention is also called to the high level of ergonomics provided by the invention even in its simplest embodiments; this ergonomics can be increased substantially at will in more expensive and sophisticated models.

**[0047]** The present invention is susceptible of modifications and variations, all of which are within the scope of the inventive concept.

**[0048]** Thus, with particular reference to Figure 6, the transmitter 15 can be inserted in the handle 20 of an iron 21 which can be connected to the appliance.

**[0049]** All the details may further be replaced with other technically equivalent elements.

**[0050]** The materials and the dimensions may be any according to requirements.

**[0051]** The disclosures in Italian Patent Application No. PD2000A000029 from which this application claims priority are incorporated herein by reference.

**[0052]** Where technical features mentioned in any claim are followed by reference signs, those reference signs have been included for the sole purpose of increasing the intelligibility of the claims and accordingly, such reference signs do not have any limiting effect on the interpretation of each element identified by way of example by such reference signs.

## Claims

1. A control device, particularly for appliances used in the field of domestic and/or industrial cleaning, characterized in that it comprises at least one radio-wave transmitter which is located on the handle of the tool of the cleaning appliance and a receiver which is located on the appliance body and is connected to means for controlling the various functions of said appliance.
2. The control device according to claim 1, characterized in that said transmitter on the handle is combined with a receiver and in that said receiver on the appliance body is combined with a transmitter.
3. The control device according to claim 1 or 2, characterized in that said means for controlling the various functions of the appliance are control switches, timers, power regulators and the like.
4. The control device according to claim 1, characterized in that the control on the handle comprises a board with said transmitter or transceiver, a removable power supply battery, a microprocessor and one or more buttons, said receiver on board the appliance being integrated in a board with a microprocessor and a memory.
5. The control device according to claim 4, characterized in that said microprocessor on the handle runs an algorithm when the battery is inserted and randomly assigns itself any one of a plurality of preset codes in order to be recognized by the appliance, and in that when the appliance is switched on the corresponding onboard board presets itself to recognize any one of the provided radio controls that is activated within a certain time period, said memory further storing the identification code sent by said transmitter when one of the control buttons on said handle is pressed.

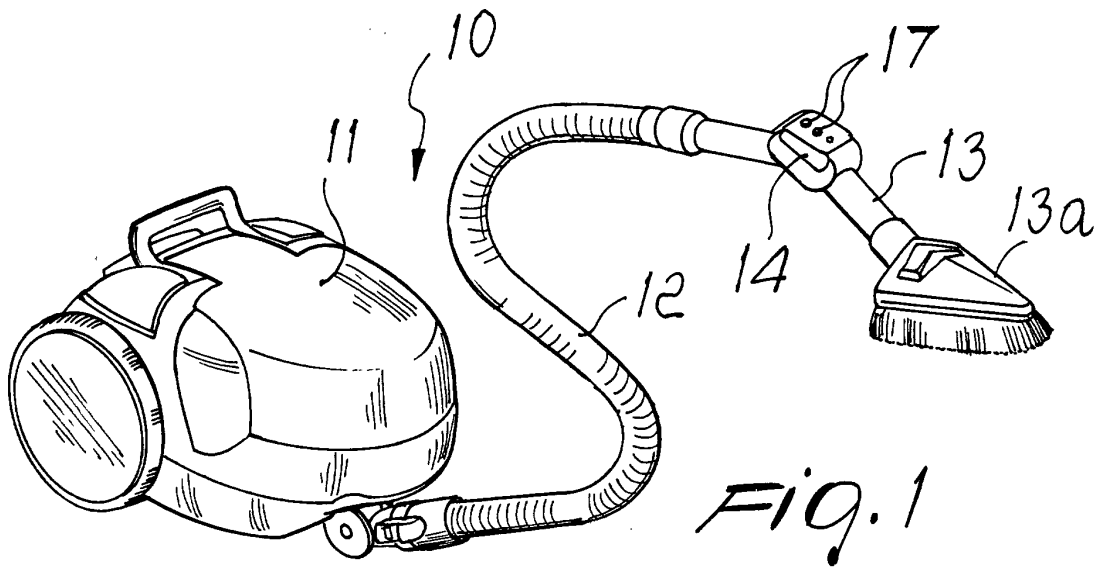

FIG. 1

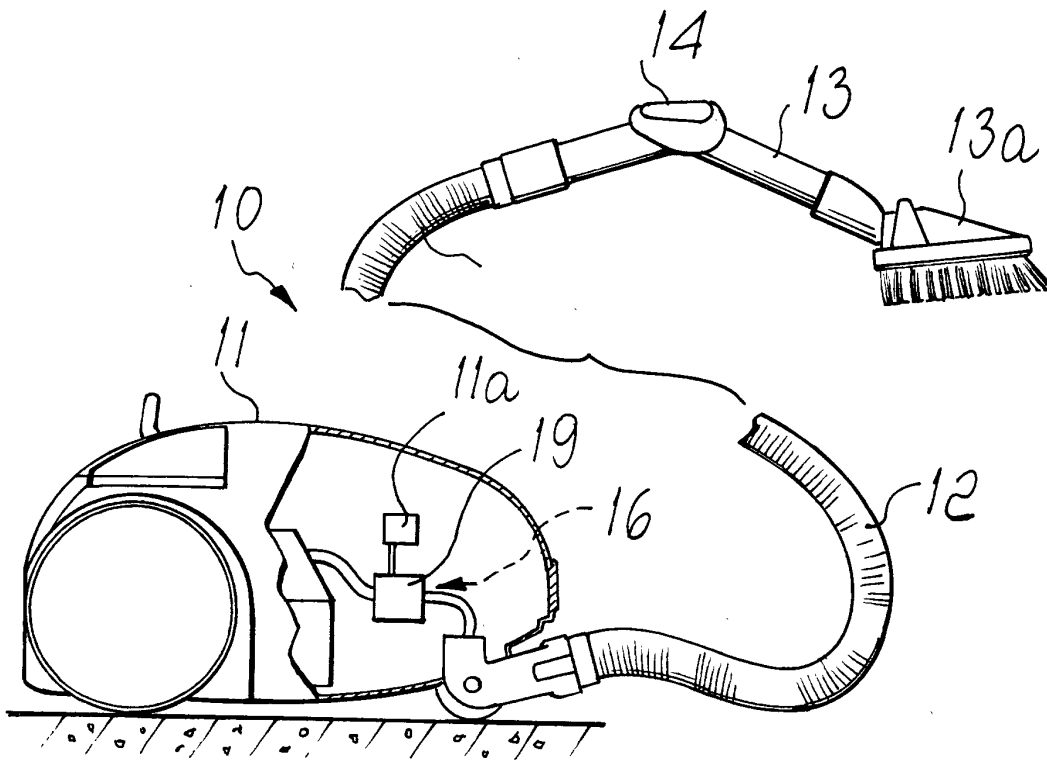

FIG. 2

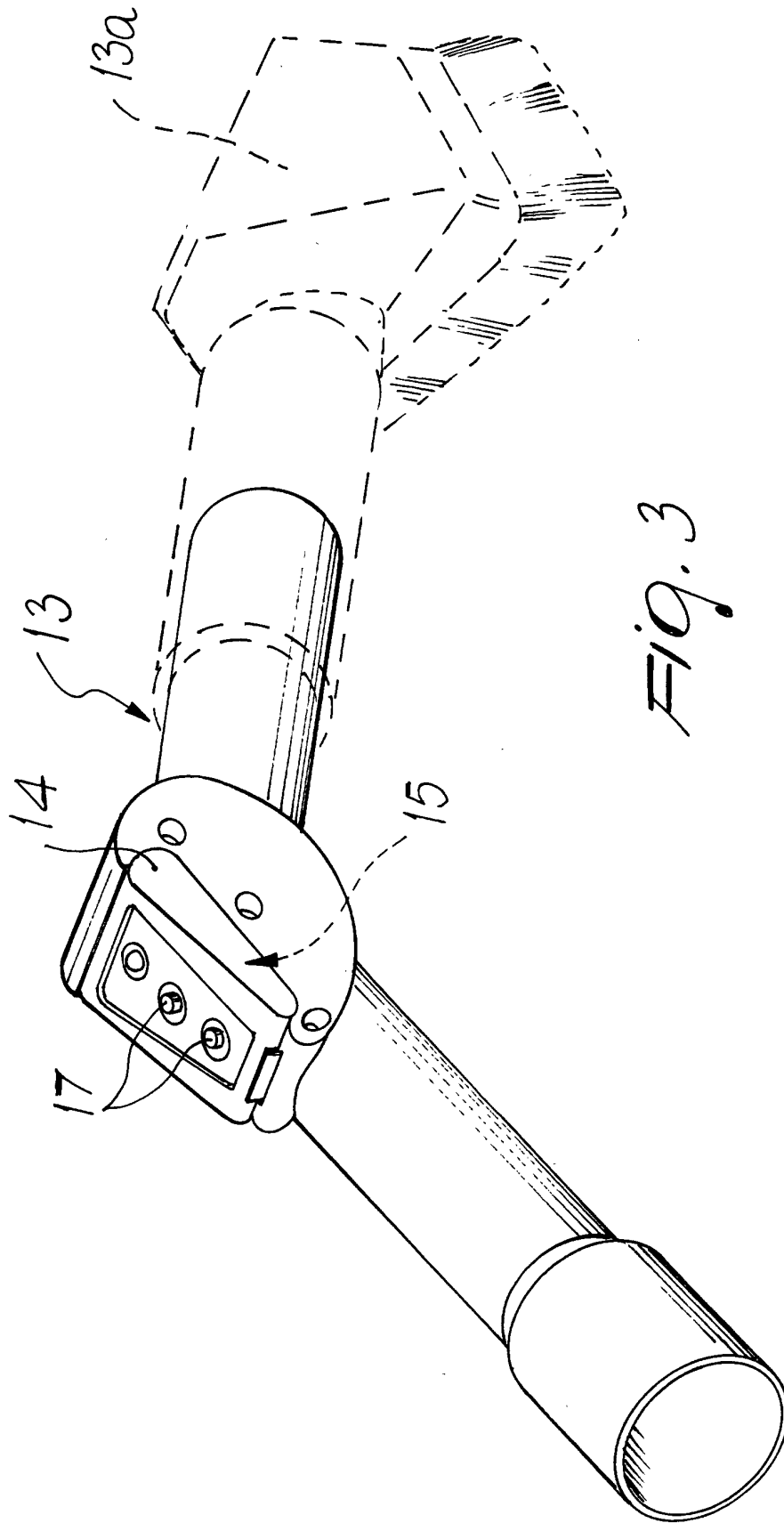

Fig. 3

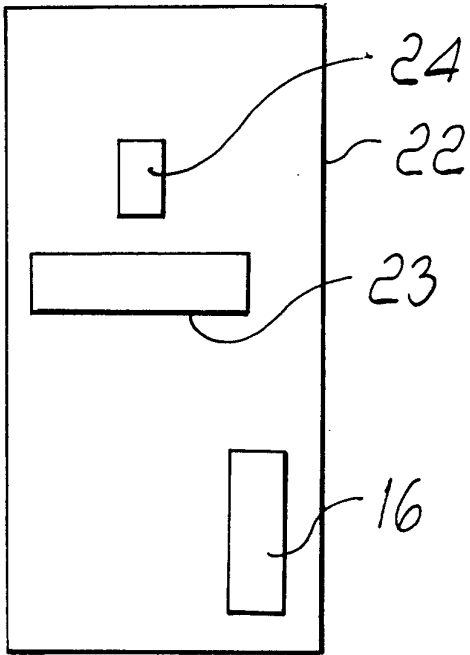

FIG. 5

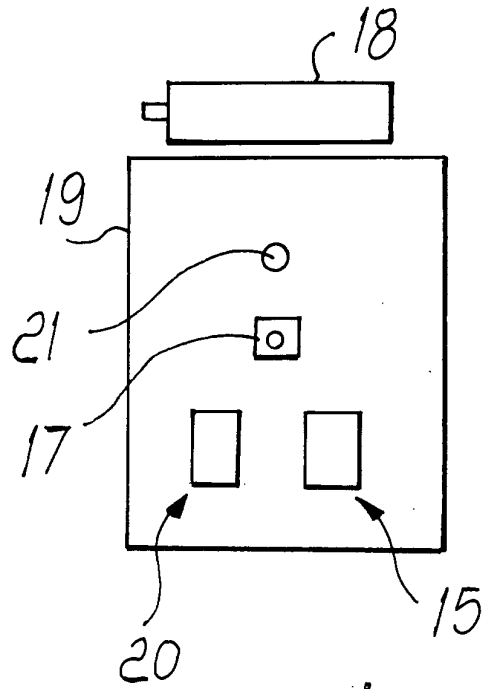

FIG. 4

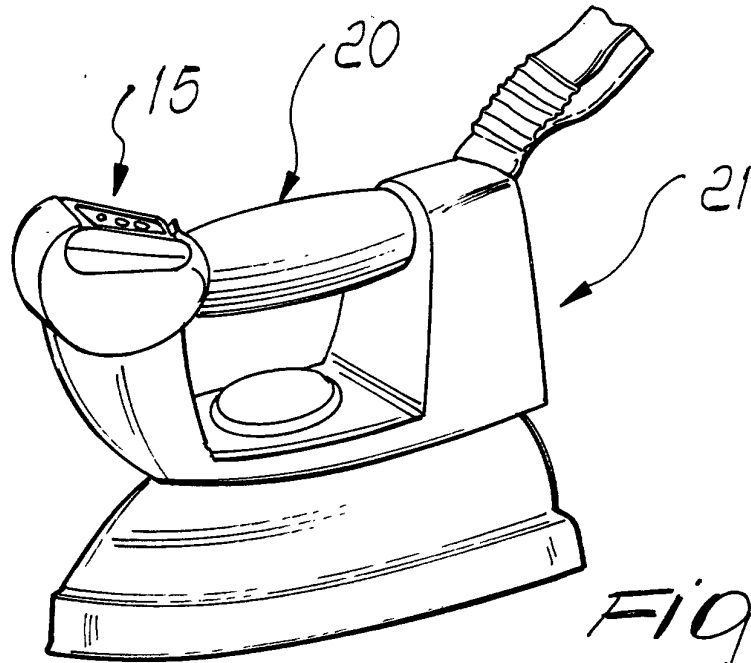

FIG. 6