

(19) **DANMARK**



Patent- og
Varemærkestyrelsen

(10) **DK/EP 3467237 T3**

(12) **Oversættelse af
europæisk patentskrift**

-
- (51) Int.Cl.: ***E 05 B 15/02 (2006.01)*** ***E 05 B 9/08 (2006.01)*** ***E 05 B 17/20 (2006.01)***
E 05 B 15/16 (2006.01) ***E 05 B 63/00 (2006.01)***
- (45) Oversættelsen bekendtgjort den: **2021-07-26**
- (80) Dato for Den Europæiske Patentmyndigheds bekendtgørelse om meddelelse af patentet: **2021-05-12**
- (86) Europæisk ansøgning nr.: **18207622.4**
- (86) Europæisk indleveringsdag: **2012-06-21**
- (87) Den europæiske ansøgnings publiceringsdag: **2019-04-10**
- (30) Prioritet: **2011-07-14 SE 1150681**
- (62) Stamansøgningsnr: **12172960.2**
- (84) Designerede stater: **AL AT BE BG CH CY CZ DE DK EE ES FI FR GB GR HR HU IE IS IT LI LT LU LV MC MK MT NL NO PL PT RO RS SE SI SK SM TR**
- (73) Patenthaver: **NoWay Security AB, Söder Mälarstrand 21, 1 tr., 118 20 Stockholm, Sverige**
- (72) Opfinder: **Holm, Sune, Floragatan 5, 114 31 Stockholm, Sverige**
Austrell, Christer, Hallonvägen 48, 196 35 Kungsängen, Sverige
- (74) Fuldmægtig i Danmark: **Larsen & Birkeholm A/S Skandinavisk Patentbureau, Banegårdspladsen 1, 1570 København V, Danmark**
- (54) Benævnelse: **Dørlåseindretning, dør og fremgangsmåde til montering af en dørlåsekonstruktion**
- (56) Fremdragne publikationer:
EP-A1- 0 072 803
DE-U1- 8 800 103
US-A- 3 715 899
US-A- 4 836 001
FORTESS AXALUX: "Det inbrottssaekra laasskyddet aer haer", , 12 August 2010 (2010-08-12), XP002767076, Retrieved from the Internet: URL:http://web.archive.org/web/20100812014958/http://www.fortaxa.se/Produktblad/Forst_arkningstillbehor.pdf [retrieved on 2017-02-09]

DESCRIPTION

BACKGROUND OF THE INVENTION AND PRIOR ART

[0001] The present invention concerns a door lock device configured for a door. The invention also concerns a door with a door lock device and a method of mounting a door lock construction at a door.

[0002] A large number of door lock devices are known. Different details of such devices are also known. The Norwegian design registration number 82202 shows for example a door lock device.

[0003] Further examples of prior art door lock devices are disclosed in: EP-0072803 comprising a cylinder-lock attachment means, and in FORTRESS AXALUC: "Det inbrottsaekra laasskyddet aer haer", 12 August 2010 (2010-08-12, XP002767076).

[0004] It is often desirable that door lock devices have a high security and that they are robust in order to resist burglary.

SUMMARY OF THE INVENTION

[0005] An object of the present invention is to provide a door lock device with high security, which is also adapted to be very stable and relatively simple to mount at a door.

[0006] These objects are achieved with the door lock device which is defined in claim 1.

[0007] Since the lock cylinder protection abuts with its first surface against the plate, and since the lock cylinder protection, or the distance element, is configured to reach the lock case, a very stable construction is obtained, with the help of the attachment means, where the plate, the lock cylinder protection, possible distance elements and the lock case in a mounted state form a stable unit, at the same time as a very high security against burglary is achieved, inter alia because of the use of the particular lock cylinder protection.

[0008] It should be noted that the term "first", "second", "third" etc. is primarily used in order to distinguish the different parts from each other and should therefore not be seen as specifying a certain number.

[0009] With cross-sectional dimension of a recess and lock cylinder is intended the dimension in a direction which in a mounted state is substantially parallel with the inside or the outside of the door.

[0010] With a lock cylinder is meant the part of the lock that interacts with a key and that has at least some movable part, for example a so-called cam, which can be moved with the help of a key and which directly or indirectly interacts with a latch bolt or similar device in the lock case for locking the door in a closed position. The concept "key" includes in this document a traditional mechanical key which is inserted into a keyhole in the lock cylinder, but also different forms of electronic keys which interact with the lock cylinder, either through direct contact with the lock cylinder or through a wireless connection with the lock cylinder. The lock can thus for example be electromechanical, wherein the cam or similar member can be moved with an "electronic" key. Such an electronic key can communicate with the lock cylinder through said first lock cylinder protection hole - either by direct contact through the first lock cylinder protection hole with a corresponding part of the lock cylinder or through wireless communication, via the first lock cylinder protection hole. The lock cylinder can have different designs, for example of the kind that is shown in Fig. 5 or of the kind that is shown in Fig. 6.

[0011] It should be noted that lock cylinders with a circular cross-section are known. Such lock cylinders often fill substantially the whole hole in the door. According to the present invention it is however that part of the first lock cylinder protection etc. which protrudes into the hole in the door which substantially fills the hole in the door. The lock cylinder is thus only configured to be positioned in the first recess. The cross-sectional area of the first recess is thus substantially smaller than the cross-sectional area of that part of the first lock cylinder protection which protrudes into the hole in the door. It is possible to configure the first recess according to the present invention for receiving a lock cylinder which has a substantially circular cross-section. According to preferred embodiments, the lock cylinder has however another cross-sectional shape, for example an oval cross-sectional shape, such as the lock cylinder which is shown in Fig. 5, or the cross-sectional shape that the lock cylinder shown in Fig. 6 has.

[0012] In case one or more distance elements are used, this or these elements thus extend, in a mounted state, all the way from the second side of the lock cylinder protection to the lock case. The same is the case preferably also for possible distance elements in connection with the second lock cylinder protection and the first and second stabilizing member, and possibly also for the holding member, which are mentioned below.

[0013] The first plate may for example be at least 15 cm, preferably at least 20 cm, long (in the vertical direction of the door in a mounted state). It may for example be at least 4.0 cm, preferably at least 5.0 cm, wide, in a direction crosswise to the length. It can have a thickness of for example at least 1.0 mm, preferably at least 2.0 mm, or at least 3.00 mm. The plate is preferably made of metal, for example of a steel alloy, preferably a hard manganese steel alloy. The same preferred dimensions and materials are also the case for the second plate, which is mentioned below.

[0014] The first plate hole is preferably circular. The hole may have an extension (diameter, if it is circular), of for example between 30 mm and 60 mm, preferably between 35 mm and 45 mm. The same preferred dimensions are the case for the second, third and fourth plate hole which are mentioned below.

[0015] The first lock cylinder protection may for example have a length such that it in a mounted state protrudes in at least 1.0 cm, preferably at least 2.0 cm inside the outside of the first plate. The same preferred length is the case for the second lock cylinder protection and for the first and second stabilizing member, and may also be the case for the holding member, which are mentioned below.

[0016] The second side of the lock cylinder protection, which side in a mounted state abuts against the lock case or against a distance element, preferably has an area of at least 2.0 cm², preferably at least 4.0 cm², most preferred at least 5.0 cm², since such an abutment surface makes the construction more stable. The corresponding preferred dimension is the case for possible distance elements and for the second side of the second lock cylinder protection, the first stabilizing member and the second stabilizing member which are mentioned below. The same dimension may also be case for the second side of the holding member which is mentioned below.

[0017] The first surface of the first lock cylinder protection preferably has an area of at least 10 cm², more preferred at least 15 cm² and most preferred at least 20 cm² in order to give a sufficient stability to the construction when this surface abuts against the first plate. Corresponding preferred dimensions are the case for the first surface of the second lock cylinder protection which is mentioned below. The corresponding first surface of the first stabilizing member preferably has an area of at least 8 cm², more preferred at least 12 cm² and most preferred at least 16 cm². The same preferred dimension is the case for the corresponding surface of the second stabilizing member and can also be the case for the corresponding surface of the holding member.

[0018] The first lock cylinder protection is preferably configured such that the lock cylinder can be locked in position in the first recess with locking means which in a mounted state is not available to a user.

[0019] An embodiment of the door lock device according to the invention is defined in claim 2. Through this embodiment, the first attachment means is implemented in a simple and secure manner. Since the screws do not reach to the outside of the door, the security of the device is increased.

[0020] According to a preferred embodiment of the door lock device, the first lock cylinder protection has only one hole on the first side, i.e. the first lock cylinder protection hole. This makes the device very safe against burglary.

[0021] A further embodiment of the door lock device according to the invention is defined in claim 3. Through this embodiment, a high stability and security is achieved.

[0022] A further embodiment of the door lock device according to the invention is defined in

claim 4. Since the part with the first surface can be moved to different positions relative to the first recess, a flexibility is achieved with the lock protection in order to be able to adapt it to different construction cases. Since the adjustable part can also be locked in a selected position, the lock protection has a high security, since in a locked position, the lock cylinder protection functions as a fixed unit. A high security is achieved since said locking means is not available from the outside of the door (and neither from the inside of the door).

[0023] A further embodiment of the door lock device according to the invention is defined in claim 5. Through this embodiment a high stability and security is achieved through the design of the first stabilizing member and possible distance elements. The plate, the stabilizing member, possible distance elements and the lock case form in a mounted state a stable unit, which makes the whole door lock construction very stable and safe.

[0024] In a similar manner as concerning the first lock cylinder protection, the portion of the first stabilizing member which comprises said first surface can, according to an embodiment, constitute a part the position of which can be adjusted in a direction which is substantially perpendicular to the surface of the door, as seen in a mounted state, relative to that portion of the first stabilizing member which comprises said second side, wherein this adjustable part can be locked in a selected position with the help of a locking means which, in a mounted state, is not available from the outside of the door (and neither from the inside of the door). Thereby a high flexibility is achieved with the first stabilizing member. It is thereby possible to adjust how much the second side protrudes into the door in a mounted state. It is therefore for example possible to ensure that in a mounted state the second side reaches the lock case and that therefore no distance element is needed in order to reach the lock case.

[0025] A further embodiment of the door lock device according to the invention is defined in claim 6. Thereby the second attachment means is realized in a simple manner.

[0026] A further feature of the door lock device according to the invention is defined in claim 1. Through a second plate the stability and the security are further increased.

[0027] The second plate may be constructed and dimensioned in the same manner as the first plate.

[0028] A further feature of the door lock device according to the invention is defined in claim 1. Through this feature, a lock turning mechanism is thus used for the inside of the door instead of a lock cylinder. The holding member thus contributes to hold the lock turning mechanism in position in a secure manner.

[0029] In a similar manner as concerning the first lock cylinder protection, that portion of the holding member which comprises said first surface, can, according to an embodiment, constitute a part the position of which can be adjusted in a direction which is substantially perpendicular to the surface of the door, as seen in a mounted state, relative to that portion of the holding member which comprises said second side, wherein this adjustable part can be

locked in a selected position with the help of a locking means which, in a mounted state, is not available from the inside of the door (and neither from the outside of the door).

[0030] A further feature of the door lock device according to the invention is defined in claim 1. Through this feature, the stability of the construction is increased also when using a lock turning mechanism on the inside of the door.

[0031] A further embodiment of the door lock device according to the invention is defined in claim 7. Through this embodiment, a high stability and security are achieved through the design of the second stabilizing member and possible distance elements. The plate, the stabilizing member, possible distance elements and the lock case form, together with the corresponding parts at the outside of the lock case, in a mounted state a stable unit, which makes the whole door lock construction very stable and safe.

[0032] In a similar manner as concerning for example the first stabilizing member, that portion of the second stabilizing member which comprises said first surface can, according to an embodiment, constitute a part the position of which can be adjusted in a direction which is substantially perpendicular to the surface of the door, as seen in a mounted state, relative to that portion of the second stabilizing member which comprises said second side, wherein this adjustable part can be locked in a selected position with the help of a locking means which, in a mounted state, is not available from the inside of the door (and neither from the inside of the door).

[0033] A further embodiment of the door lock device according to the invention is defined in claim 8. This embodiment has the advantage that no extra screws or screw holes are needed in the plates for safely arranging the plates at the door. This simplifies essentially the mounting of the door lock device at a door.

[0034] A door according to the invention is defined in claim 9. This door has the advantage that it has a door lock device according to the invention, which makes the door/lock-construction very stable and secure against burglary.

[0035] A method according to the invention is defined in claim 10. With this method a door according to the invention is realized, with the advantages that this door has, in a simple manner.

BRIEF DESCRIPTION OF THE DRAWINGS

[0036]

Fig. 1

shows schematically a front view of a first lock cylinder protection.

Fig. 2

shows schematically a perspective view from behind of the lock cylinder protection of Fig. 1.

Fig. 3

shows schematically an inclined perspective view from the front of a second lock cylinder protection.

Fig. 4

shows schematically a perspective view from behind of the lock cylinder protection of Fig. 3.

Fig. 5

shows schematically an exploded view of an alternative embodiment of the first lock cylinder protection.

Fig. 6

shows schematically a perspective view of one kind of lock cylinder.

Fig. 7-9

show schematically a front view of different embodiments of a first and a second plate.

Fig. 10

shows schematically an exploded view of a door with a door lock device according to an example not forming part of the invention.

Fig. 11

shows an exploded view similar to that of Fig. 10 of an embodiment according to the invention.

DESCRIPTION OF EMBODIMENTS OF THE INVENTION

[0037] Embodiments of the invention will now be described with reference to the annexed drawings. The embodiments describe lock cylinders with a keyhole for interaction with a traditional mechanical key. However, as mentioned above, the invention is also applicable for other kinds of lock cylinders which interact with an "electronic" key.

[0038] An example of a door lock device not forming part of the invention, but which is useful for understanding the invention will now first be described with reference to Fig. 10. This figure shows for the purpose of clarity an exploded view of a door 30 with a door lock device. The door 30 has a first door hole 21 which extends through the door from its outside 31 to its inside 32. The door also has a second door hole 22 which also extends from the outside 31 of the door to the inside 32 of the door. In the door a lock case 23 is arranged. In the first door hole 21, a lock cylinder 40 is arranged (the lock cylinder is shown in one embodiment in Fig. 5 and in another in Fig. 6). The lock cylinder is arranged in a first lock cylinder protection 41. In a mounted state, the lock cylinder 40 extends from the outside 31 of the door into the door hole 21 to the lock case 23 such that the lock cylinder 40 can interact with the lock case 23 in order to lock and unlock the lock.

[0039] The door lock device also has a first plate 51 with a first plate hole 53 and a second plate hole 54. The plate 51 abuts, in a mounted state, against the outside 31 of the door such that the first plate hole 53 coincides with the first door hole 21 and the second plate hole 54 coincides with the second door hole 22. Different examples of the design of such a first plate is shown in Fig. 7-9.

[0040] The door lock device also comprises a second plate 52 with a third plate hole 55 and a fourth plate hole 56. The second plate 52 abuts in a mounted state against the inside 32 of the door. The third plate hole 55 coincides thereby with the first door hole 21 and the fourth plate hole 56 coincides with the second door hole 22. The second plate 52 can have the same appearance as the first plate 51. Fig. 7-9 thus also show examples of different embodiments of the second plate 52. As can be seen in Fig. 8, the plates 51, 52 may also possibly have a further hole 122. This hole 122 is intended for a screw which goes into or through the lock case 23 which is mounted in the door. Fig. 9 shows another hole 120. The hole 120 is intended for a door handle, which is used in certain door constructions and which is connected to the lock case 23 which is arranged in the door.

[0041] According to these embodiments of the plates 51, 52 there are no further holes through the plates 51, 52 which are intended for screws which are to hold the plates 51, 52 attached at the door 30. Such further holes are not necessary with the present invention since the plates 51, 52 anyway are held safely mounted at the door 30.

[0042] The first lock cylinder protection 41 is shown in more detail in Fig. 1 and 2. This lock cylinder protection 41 has a first side 43 which in a mounted state lies outside the door surface and outside the first plate 51. The lock cylinder protection 41 has a second side 45 which in a mounted state lies in the door 30 in the door hole 21. Furthermore, the lock cylinder protection 41 has a first recess 47.

[0043] This recess 47 has a cross-sectional dimension which is adapted for receiving the lock cylinder 40. The recess 47 extends from the second side 45 towards the first side 43 but not all the way to the first side 43. However, there is a first lock cylinder protection hole 49 which has a smaller cross-sectional dimension than the first recess 47 and than the lock cylinder 40 and which extends from the first recess 47 out through the first side 43. A key can thus be inserted in through the first lock cylinder protection hole 49 into a keyhole 60 in the lock cylinder 40 (see Fig. 5 and 6) in order to lock or unlock the lock. As mentioned above, it is also possible to use some kind of "electronic" key which communicates with the lock cylinder via the first lock cylinder protection hole 49.

[0044] The lock cylinder 40 can be locked in position in the first recess 47 for example in that one or more lock screws 128 (see Fig. 5) are screwed into holes 126 and thereby lock the lock cylinder 40 fixed in the lock cylinder protection 41.

[0045] The lock cylinder protection 41 has a first surface 62 which in a mounted state abuts against the surface of the first plate 51 around the first plate hole 53.

[0046] When we in this application say that the part abuts against the surface, this includes the possibility that the abutment takes place via some intermediate element. Fig. 2 thus shows a sealing packing 124 arranged in a recess in the first surface 62. Fig. 2 shows also another sealing packing 124 which seals against the lock cylinder 40 when it is inserted in the recess 47.

[0047] The first lock cylinder protection 41 is held in position at the door 30 with the help of a first attachment means 64 in the form of two screws (one such screw is shown in Fig. 10). The screws 64 extend from the inside 32 of the door and are connected to the first lock cylinder protection 41 by being screwed into screw holes 68 in the first lock cylinder protection 41. These screw holes 68 extend from the second side 45 but not through the whole first lock cylinder protection 41 to its first side 43. When the screws 64 have been screwed, these exert a force on the first lock cylinder protection 41 in the direction in towards the door 30. The first surface 62 thus exerts a pressure force against the first plate 51 in the direction towards the outside 31 of the door. The first plate 51 is thus held in position against the outside of the door.

[0048] The first lock cylinder protection 41 can have such a length that it in a mounted state reaches the surface of the lock case 23 in such a manner that the second side 45 of the lock cylinder protection 41 abuts directly against the surface of the lock case when the lock cylinder protection 41 is held attached at the door with the help of the screws 64. Alternatively, the device can comprise one or more distance elements 66 (only shown in the lower part of Fig. 10) which are arranged between the second side 45 of the lock cylinder protection 41 and the lock case 23 in such a manner that in a mounted state that side of said distance element which is facing the lock case 23 reaches to the lock case 23 and abuts against the surface of the lock case when the lock cylinder protection 41 is held attached at the door with the help of the screws 64.

[0049] In Fig. 1 and 2 it is shown that the portion of the first lock cylinder protection 41 which comprises the first surface 62 constitutes one single solid part together with the portion of the lock cylinder protection 41 which comprises the recess 47.

[0050] In Fig. 5 an alternative embodiment is shown where the portion of the lock cylinder protection 41 which comprises the first surface 62 constitutes a separate part 70 the position of which can be adjusted relative to the portion 72 of the first lock cylinder protection 41 which comprises the first recess 47. The adjustment can be made possible in that the outer surface of the portion 72 is threaded and in that there is a corresponding internal thread in a hole in the part 70. The position of the part 70 can thus be selected in that this part is screwed onto the portion 72 until a selected position has been achieved. The part 70 can be locked in the selected position with the help of a locking means 74. The locking means 74 is according to this embodiment a ball. This ball 74 can be inserted from the recess 47 (which is hidden in Fig. 5) through a hole 132 through the wall of the portion 72 in order to protrude into a selected recess 130 at the part 70. The ball 74 thus locks the part 70 relative to the portion 72 in the selected position.

[0051] Fig. 10 also shows a turning device 76 from a door handle 78. In a mounted state, the turning device 76 extends from the door handle 78 on the outside 31 or the door into the second door hole 22 to the lock case 23. The turning device 76 interacts with the lock case 23 such that you can open and close the door 30 with the help of the door handle 78. On the inside 32 of the door there is a corresponding arrangement.

[0052] A first stabilizing member 80 has a first side 82 which in a mounted state lies outside the door surface and outside the first plate 51. The stabilizing member 80 has a second side 84 which in a mounted state lies in the door 30 in the second door hole 22. The stabilizing member 80 has a first surface 86 which in a mounted state abuts, directly or indirectly, against the surface of the first plate 51 around the second plate hole 54.

[0053] In a corresponding manner there is a door handle 78 on the inside 32 of the door 30. The door handle interacts with the turning device 76 which extends from the inside 32 of the door into the door hole 22 to the lock case 23. You can thus open and close the door with the help of the door handle 78 on the inside of the door 30, in that the turning device 76 interacts with the lock case 23. The turning device 76 can for example be a through shaft which extends through the whole second hole 22 and through the lock case 23.

[0054] A second stabilizing member 110 is arranged in a corresponding manner as the first stabilizing member 80. The second stabilizing member 110 thus has a first side 82 which in a mounted state lies inside the door surface on the inside 32 of the door and inside the second plate 52. A second side 84 lies in a mounted state in the door in the second door hole 22. A first surface 86 of the second stabilizing member 110 abuts in a mounted state directly or indirectly against the second plate 52 around the fourth plate hole 56.

[0055] A second attachment means 65 in the form of two screws holds the first stabilizing member 80 and the second stabilizing member 110 attached. In the shown embodiment, the screws 65 extend through a flat member 111 at the door handle 78, through the second stabilizing member 110, through the distance element 66, through, or at the side of, the lock case 23, through further distance elements 66, through the first stabilizing member 80 and through a flat member 87 arranged at the door handle 78 on the outside of the door, such that the screws 65 are screwed into sex bolts 65b.

[0056] According to an alternative embodiment, the screws 65 can be screwed into threaded screw holes in the first stabilizing member 80, which screw holes extend from the second side 84 but which do not reach to the first side 86 (i.e. in a similar manner as the screws 64 are screwed into the screw holes 68 in the first lock cylinder protection 41).

[0057] When the screws 65 have been screwed, the screws 65 exert a force on the first stabilizing member 80 in the direction towards the door such that the first surface 86 of the first stabilizing member 80 exerts a pressure force against the first plate 51 in the direction towards the outside of the door such that the first plate 51 is held in position against the outside of the door. At the same time, the screws 65 exert a force on the second stabilizing member 110 in

the direction in towards the door 30 such that the first surface 86 of the second stabilizing member 110 exerts a pressure force against the second plate 52 in the direction towards the inside 32 of the door such that the second plate 52 is held in position against the inside 32 of the door.

[0058] The first stabilizing member 80 can have such a length that it in a mounted state reaches a surface of the lock case 23 such that it abuts with its second side 84 against the surface of the lock case when the first stabilizing member 80 is held attached at the door with the help of the screws 65. Alternatively, as is shown in Fig. 10, there is one or more distance elements 66 which are arranged between the second side 84 of the first stabilizing member 80 and the lock case 23, such that in a mounted state that side of the distance elements 66 which is facing the lock case 23 abuts against the surface of the lock case when the stabilizing member 80 is held attached at the door with the help of the screws 65.

[0059] In a similar manner, the second stabilizing member 110 can have a length such that it reaches the lock case 23 and such that it abuts with its second side 84 against the lock case when the stabilizing member 110 is held attached with the help of the screws 65. Alternatively, one or more distance elements 66 can be arranged also between the second side 84 of the second stabilizing member and the lock case 23 such that that side of the distance elements which is facing the lock case 23 abuts against the lock case when the second stabilizing member 110 is held attached at the door with the help of the screws 65.

[0060] A second lock cylinder protection 91 is arranged from the inside of the door. Such a second lock cylinder protection 91 is shown in Fig. 3 and 4. The second lock cylinder protection 91 has a similar construction as the first lock cylinder protection 41. The second lock cylinder protection 91 thus has a second recess 93 which is adapted to receive a lock cylinder 40. The recess 93 extends from the second side 45 towards the first side 43 but not all the way to the first side. A second lock cylinder protection hole 95 which has a smaller cross-sectional dimension than the second recess 93 and than the lock cylinder 40 extends however from the second recess 93 out through the first side 43 in a corresponding manner as at the first lock cylinder protection 41. A key may thus interact with a lock cylinder 40 which is arranged in the recess 93 via the second lock cylinder protection hole 95.

[0061] The second lock cylinder protection 91 differs however from the first lock cylinder protection 41 in that there are through screw holes 130, which extend from the first side 43 to the second side 45.

[0062] These screw holes 130 are intended for the first attachment means, that is the screws 64. Furthermore, there are two screw holes 132 which extend from the first side 43 into the recess 93. These screw holes 132 are intended for screws which are screwed through holes in a lock cylinder 40 which is arranged in the recess 93.

[0063] The second lock cylinder protection 91 has a first surface 62 which in a mounted state, directly or indirectly, abuts against the surface of the second plate 52 around the third plate

hole 55. In a mounted state, the screws 64 hold the second lock cylinder protection 91 attached at the door. The screws thereby exert a force on the second lock cylinder protection 91 in the direction towards the door (in that they are screwed into the screw holes 68 in the first lock cylinder protection 41) such that the first surface 62 of the second lock cylinder protection 91 exerts a pressure force against the second plate 52 in the direction towards the inside 32 of the door. In such a manner, the second plate 52 is held in position against the inside 32 of the door.

[0064] The second lock cylinder protection 91 can have such a length that it in a mounted state reaches the lock case 23 such that the second side 45 abuts against the lock case 23 when the second lock cylinder protection 91 is held attached at the door with the help of the screws 64. Alternatively, one or more distance elements 66 can be arranged between the second side 45 of the second lock cylinder protection 91 and the lock case 23 such that that side of the distance elements which is facing the lock case 23 reaches the lock case and abuts against the surface of the lock case when the second lock cylinder protection 91 is held attached at the door with the help of the screws 64.

[0065] In a similar manner as concerning the embodiment of the first lock cylinder protection 41 which is shown in Fig. 5, that portion of the second lock cylinder protection 91 which comprises said first surface 62 can, according to a not shown embodiment, constitute a part the position of which can be adjusted in a direction which is substantially perpendicular to the surface of the door, as seen in a mounted state, relative to that portion of the second lock cylinder protection 91 which comprises said second recess 93, wherein this adjustable part can be locked in a selected position with the help of a locking means which, in a mounted state, is not available from the inside of the door.

[0066] Fig. 11 shows an embodiment according to the invention which differs from the example in Fig. 10 in that there is a lock turning mechanism 100 at the inside of the door at the first door hole 21 and in that there at the second door hole 22 are no door handles or no turning device similar to that which has been shown in connection with Fig. 10.

[0067] Instead of the second lock cylinder protection 91 which is shown in Fig. 10, there is in the embodiment according to Fig. 11 a holding member 101 which has a first side 43 which in a mounted state lies inside the door surface on the inside 32 of the door and inside the second plate 52. The holding member 101 has a second side 45 which in a mounted state lies in the door in the first door hole 21. In a mounted state, a lock turning mechanism 100 extends through the holding member 101 to the lock case 23 such that the lock turning mechanism can interact with the lock case 23 in order to lock and unlock the lock. The holding member 101 has a first surface (corresponding to the surface 62 which has been described above) which in a mounted state abuts, directly or indirectly, against the second plate 52 around the third plate hole 55. Screws 64 hold the holding member 101 attached at the door such that the holding member 101 exerts a force in the direction towards the door such that the first surface of the holding member 101 exerts a pressure force against the second plate 52 in the direction towards the inside 32 of the door. The second plate 52 is thereby held in position against the

inside of the door.

[0068] Also the holding member 101 can possibly have such a length that it in a mounted state reaches the lock case 23, such that the second side 45 abuts against the surface of the lock case when the holding member 101 is held attached at the door with the help of the screws 64. Alternatively, one or more distance elements 66 can possibly be arranged between the second side 45 of the holding member 101 and the lock case 23 such that in a mounted state that side of the distance elements which is facing the lock case 23 reaches the lock case and abuts against the surface of the lock case when the holding member 101 is held attached at the door with the help of the screws 64.

[0069] Since there in the embodiment according to Fig. 11 is no turning device 76, the first stabilizing member 80 and the second stabilizing member 110 do not, according to this embodiment, need to have any holes, except for holes for the screws 65. These holes for the screws are extending through the second stabilizing member 110 and can be extending through the first stabilizing member 80, and thereby be screwed into for example sex bolts 65b. According to a preferred embodiment, the first stabilizing member 80 does however have threaded screw holes which do not reach out through the first side 82, whereby no sex bolts 65b are needed.

[0070] In a corresponding manner, possible distance elements 66 according to the embodiment of Fig. 11 only need to have holes for the screws 65.

[0071] Although not shown in the figures, in a similar manner as concerning the embodiment of the first lock cylinder protection 41 which is shown in Fig. 5, that portion of the first stabilizing member 80 and/or the second stabilizing member 110 and/or the holding member 101 which comprises said first surface 86 can constitute a part the position of which can be adjusted in a direction which is substantially perpendicular to the surface of the door, as seen in a mounted state, relative to that portion of the first stabilizing member 80, the second stabilizing member 110 and the holding member 101, respectively, which comprises said second side 84, 45, wherein this adjustable part can be locked in a selected position with the help of a locking means which, in a mounted state, is not available from the outside or the inside of the door.

[0072] In order to further strengthen the arrangement of the first and/or second stabilizing member 80, 110 at the respective plate 51, 52, the respective stabilizing member 80, 110 can, according to a not shown embodiment, be attached at the respective plate 51, 52 with the help of further screws. For example, the first stabilizing member 80 can have two or more threaded screw holes in through the first surface 86, but which do not reach out through the first stabilizing member 80. The plate 51 can have corresponding non-threaded holes for screws. In such a manner, screws can be screwed (before mounting the plate at the door) from the inside of the plate 51 through the holes in the plate 51 into the screw holes in the surface 86 in order to further ensure that the first stabilizing member 80 is held attached at the plate 51. Alternatively, non-threaded screw holes can be arranged which extend in through the surface 86 out through the outside of the first stabilizing member 80. Screws can then for example be

screwed in from the outside, through these non-threaded screw holes and into corresponding threaded screw holes in the plate 51 (or, alternatively, be screwed into nuts or sex bolts at the inside of the plate 51). In a corresponding manner, the second stabilizing member 110 can be connected to the plate 52 via further threaded or non-threaded screw holes in through the surface 86 on the second stabilizing member 110.

[0073] Possibly, corresponding screw holes (non-threaded through screw holes or threaded non-through holes) can also be arranged in the upper part in the first surface 62 of the first and/or second lock cylinder protection 41, 91 or of the holding member 101, with corresponding threaded or non-threaded holes at the respective plate 51, 52.

[0074] A door 30 according to the invention comprises a door lock device according to the invention in a mounted state. When the parts have been mounted and when the screws 64 and 65 have been tightened, Fig. 11 thus illustrate an embodiment of a door according to the invention.

[0075] A method of mounting a door lock construction according to the invention can comprise the following steps.

[0076] A lock case 23, at least one lock cylinder 40 and a door lock device according to the invention are provided.

[0077] The lock case 23 is arranged in the door 30 at a position intended therefor in level with the first door hole 21 and the second door hole 22.

[0078] The lock cylinder 40 is arranged in the recess 47 in the first lock cylinder protection 41.

[0079] The door lock device is arranged as has been described above at the door with the help of the screws 64, 65.

[0080] The invention is not limited to the described embodiments but can be modified within the scope of the following claims.

REFERENCES CITED IN THE DESCRIPTION

This list of references cited by the applicant is for the reader's convenience only. It does not form part of the European patent document. Even though great care has been taken in compiling the references, errors or omissions cannot be excluded and the EPO disclaims all liability in this regard.

Patent documents cited in the description

- EP0072803A [0003]

Non-patent literature cited in the description

- **FORTRESS AXALUC**Det inbrottsaekra laasskyddet aer haer, 2010, [0003]

P A T E N T K R A V

1. Dørlåseindretning indrettet til en dør (30) med et første dørhul (21), som strækker sig fra dørens yderside (31) til dørens inderside (32), og hvori en låsecylinder (40) er beregnet til at være anbragt således, at den strækker sig fra dørens yderside (31) ind i det første dørhul (21) i retningen mod en låsekasse (23), som er anbragt i døren (30) på sådan en måde, at låsecylinderen (40) kan interagere med låsekassen (23) for at låse og oplåse låsen, hvor dørlåseindretningen omfatter:

en første plade (51) med et første pladehul (53), hvilken plade (51) er beregnet til at ligge an mod dørens yderside (31) således, at det første pladehul (53) falder sammen med det første dørhul (21),

en første låsecylinderbeskyttelse (41) med en første side (43), som i en monteret tilstand ligger uden for dørfladen og uden for den første plade (51), en anden side (45), som i en monteret tilstand ligger i døren (30) i det første dørhul (21), hvor den første låsecylinderbeskyttelse (41) har en første reces (47) med en tværsnitsdimension tilpasset til at optage en låsecylinder (40), hvilken reces strækker sig fra den anden side (45) mod den første side (43),

men ikke hele vejen til den første side, men hvor et første låsecylinderbeskyttelseshul (49), som har en mindre tværsnitsdimension end den første reces (47) og end låsecylinderen (40), strækker sig fra den første reces (47) ud gennem den første side (43), hvor det første låsecylinderbeskyttelseshul (49) er indrettet således, at en nøgle i en monteret tilstand via det første låsecylinderbeskyttelseshul (49) kan interagere med låsecylinderen (40), som er positioneret i den første reces (47), enten ved at nøglen indføres i et nøglehul (60) i låsecylinderen (40), eller ved at nøglen kommunikerer med låsecylinderen (40) på en anden måde, hvor den første låsecylinderbeskyttelse (41) omfatter en første flade (62), som i en monteret tilstand er indrettet til,

direkte eller via et eller flere yderligere elementer, at ligge an mod fladen på den første plade (51) omkring det første pladehul (53) og således omkring

det første dørhul (21), et første fastgørelsesmiddel (64), som er beregnet til at holde den første låsecylinderbeskyttelse (41) fastgjort på døren, hvilket første fastgørelsesmiddel (64) er beregnet til at strække sig fra dørens inder-
5 uden at strække sig ud gennem den første side (43) af den første låsecylinderbeskyttelse (41), hvor det første fastgørelsesmiddel (64) er beregnet til at udøve en kraft på den første låsecylinderbeskyttelse (41) i retningen ind mod døren, således at den første flade (62) gennem denne kraft udøver en trykkraft mod den første plade (51) i retningen mod dørens yderside (31),
10 således at den første plade (51) holdes i position mod dørens yderside, hvor enten

a) den første låsecylinderbeskyttelse (41) har sådan en længde, at den i en monteret tilstand når en flade på låsekassen (23), som er monteret i døren, og ligger an med sin anden side (45) mod fladen på låsekassen (23), når den første låsecylinderbeskyttelse (41) holdes fastgjort på døren ved hjælp af det første fastgørelsesmiddel (64),
15 eller

b) dørlåseindretningen omfatter mindst et afstandselement (66), som er indrettet til at være anbragt mellem den anden side (45) af den første låsecylinderbeskyttelse (41) og låsekassen (23), som er monteret i døren, således at den side af afstandselementet (66), som vender mod låsekassen (23) i døren, i en monteret tilstand når en flade på låsekassen (23) og ligger an mod denne flade, når den første låsecylinderbeskyttelse (41) holdes fastgjort på døren ved hjælp af det
20 første fastgørelsesmiddel (64),
25

hvor dørlåseindretningen omfatter:

en anden plade (52) med et tredje pladehul (55), hvilken plade (52) er beregnet til at ligge an mod dørens inderside (32) således, at det tredje pladehul (55) falder sammen med det første dørhul (21), og en låsedrejeme­kanisme (100), som er beregnet til at kunne låse og oplåse låsen fra dørens inderside uden at anvende en nøgle, hvor dørlåseindretningen endvidere omfatter:

et holdeelement (101) med en første side (43), som i en monteret tilstand ligger inde i dørlfladen på dørens inderside (32) og inde i den anden plade (52), en anden side (45), som i en monteret tilstand ligger i døren i det første dørhul (21), hvor låsedrejeme­kanismen (100) i en monteret tilstand strækker sig gennem holde­elementet (101) til låsekassen (23) således, at låsedrejeme­kanismen (100) i en monteret tilstand kan inter­agere med låsekassen (23) for at låse og oplåse låsen, hvor holde­elementet (101) omfatter en første flade, som i en monteret tilstand er indrettet til, direkte eller via et eller flere yderligere elementer, at ligge an mod fladen på den anden plade (52) omkring det tredje pladehul (55) og således omkring det første dørhul (21), hvor det første fastgørelsesmiddel (64) også er beregnet til at holde holde­elementet (101) fastgjort på døren, hvor det første fastgørelses­middel (64) er beregnet til at udøve en kraft på holde­elementet (101) i retningen mod døren, således at den første flade på holde­elementet (101) gennem denne kraft udøver en trykkraft mod den anden plade (52) i retningen mod dørens inderside (32), således at den anden plade (52) holdes i position mod dørens inderside, hvor enten

- a) holde­elementet (101) har sådan en længde, at det i en monteret tilstand når en flade på låsekassen (23), som er monteret i døren, og ligger an med sin anden side (45) mod fladen på

låsekassen (23), når holdeelementet (101) holdes fastgjort på døren ved hjælp af det første fastgørelsesmiddel (64),
eller

- 5 b) dørlåseindretningen omfatter mindst et afstandselement (66),
som er indrettet til at være anbragt mellem den anden side (45)
af holdeelementet (101) og låsekassen (23), som er monteret i
døren, således at den side af afstandselementet (66), som
vender mod låsekassen (23) i døren, i en monteret tilstand når
en flade på låsekassen og ligger an mod denne flade, når
10 holdeelementet (101) holdes fastgjort på døren ved hjælp af det
første fastgørelsesmiddel (64).

2. Dørlåseindretning ifølge krav 1, hvor det første fastgørelsesmiddel (64) omfatter mindst to skruer, som i en monteret tilstand er forbundet med den første låsecylinderbeskyttelse (41) ved at være skruet ind i gevindskårne skruehuller (68) i den første låsecylinderbeskyttelse (41), hvilke gevindskårne skruehuller (68) strækker sig fra den anden side (45) af den første låsecylinderbeskyttelse (41), men ikke gennem hele den første låsecylinderbeskyttelse (41) til dens første side (43).

3. Dørlåseindretning ifølge et hvilket som helst af de foregående krav, hvor det afsnit af den første låsecylinderbeskyttelse (41), som omfatter den første flade (62), udgør en enkelt massiv del sammen med det afsnit af den første låsecylinderbeskyttelse (41), som omfatter den første reces (47).

4. Dørlåseindretning ifølge et hvilket som helst af kravene 1-2, hvor det afsnit af den første låsecylinderbeskyttelse (41), som omfatter den første flade (62), udgør en del (70), hvis position kan justeres i en retning, som er i det væsentlige vinkelret på dørens flade, set i en monteret tilstand, i forhold til det afsnit (72) af den første låsecylinderbeskyttelse (41), som omfatter den første reces (47), hvor

denne justerbare del (70) kan låses i en valgt position ved hjælp af et låsemiddel (74), som i en monteret tilstand ikke er tilgængeligt fra dørens yderside.

5 5. Dørlåseindretning ifølge et hvilket som helst af de foregående krav, som er indrettet til en dør (30), som også har et andet dørhul (22), som strækker sig fra dørens yderside (31) til dørens inderside (32), og hvori for eksempel en drejeindretning (76) fra et dørhåndtag (78) er beregnet til at være anbragt således, at den strækker sig fra dørens yderside (31) ind i det andet dørhul i retningen mod en låsekasse (23), som er anbragt i døren på sådan en måde, at drejeindretningen 10 (76) kan interagere med låsekassen (23) for at åbne og lukke døren (30), hvor den første plade (51) omfatter et andet pladehul (54), som er anbragt således, at det andet pladehul (54) i en monteret tilstand falder sammen med det andet dørhul (22), og hvor dørlåseindretningen omfatter:

15 et første stabiliseringselement (80) med en første side (82), som i en monteret tilstand ligger uden for dørfladen og uden for den første plade (51), en anden side (84), som i en monteret tilstand ligger i døren i det andet dørhul (22), hvor det første stabiliseringselement omfatter en første flade (86), som i en monteret tilstand er indrettet til, direkte eller via et eller flere yderligere 20 elementer, at ligge an mod fladen på den første plade (51) omkring det andet pladehul (54) og således omkring det andet dørhul (22), et andet fastgørelsesmiddel (65), som er beregnet til at holde det første stabiliseringselement (80) fastgjort på døren, hvilket andet fastgørelsesmiddel (65) er beregnet til at strække sig fra dørens inderside (32) og til at 25 være forbundet med det første stabiliseringselement (80) eller med et element (87) anbragt uden for det første stabiliseringselement (80), hvor det andet fastgørelsesmiddel (65) er beregnet til at udøve en kraft på det første stabiliseringselement (80) i retningen ind mod døren, således at den første flade (86) på det første stabiliseringselement (80) gennem denne kraft 30 udøver en trykkraft mod den første plade (51) i retningen mod dørens

yderside (31), således at den første plade (51) holdes i position mod dørens yderside,
hvor enten

- 5 a) det første stabiliseringselement (80) har sådan en længde, at det i en monteret tilstand når en flade på låsekassen (23), som er monteret i døren, og ligger an med sin anden side (84) mod fladen på låsekassen, når det første stabiliseringselement (80) holdes fastgjort på
- 10 eller
- b) dørlåseindretningen omfatter mindst et afstandselement (66), som er indrettet til at være anbragt mellem den anden side (84) af det første stabiliseringselement (80) og låsekassen (23), som er monteret i
- 15 mod låsekassen (23) i døren, i en monteret tilstand når en flade på låsekassen og ligger an mod denne flade, når det første stabiliseringselement (80) holdes fastgjort på døren ved hjælp af det andet fastgørelsesmiddel (65).
- 20 6. Dørlåseindretning ifølge krav 5, hvor det andet fastgørelsesmiddel omfatter mindst to skruer (65).
- 25 7. Dørlåseindretning ifølge et hvilket som helst af de foregående krav, indrettet til en dør, som også har et andet dørhul (22), som strækker sig fra dørens yderside (31) til dørens inderside (32), og hvori for eksempel en drejeindretning (76) fra et dørhåndtag (78) er beregnet til at være anbragt således, at den strækker sig fra dørens inderside (32) ind i det andet dørhul (22) i retningen mod en låsekasse (23), som er anbragt i døren på sådan en måde, at drejeindretningen (76) kan interagere med låsekassen (23) for at åbne og lukke døren,

hvor den anden plade (52) omfatter et fjerde pladehul (56), som er anbragt således, at det fjerde pladehul (56) i en monteret tilstand falder sammen med det andet dørhul (22), og hvor dørlåsebeskyttelsen omfatter:

- 5 et andet stabiliseringselement (110) med en første side (82), som i en monteret tilstand ligger inde i dørladen på dørens inderside (32) og inde i den anden plade (52), en anden side (84), som i en monteret tilstand ligger i døren i det andet dørhul (22),
- 10 hvor det andet stabiliseringselement (110) omfatter en første flade (86), som i en monteret tilstand er indrettet til, direkte eller via et eller flere yderligere elementer, at ligge an mod fladen på den anden plade (52) omkring det fjerde pladehul (56) og således omkring det andet dørhul (22),
- 15 et andet fastgørelsesmiddel (65), som er beregnet til at holde det andet stabiliseringselement (110) fastgjort på døren, hvilket andet fastgørelsesmiddel (65) er beregnet til at strække sig fra dørens inderside (32) og til at være forbundet med det andet stabiliseringselement (110) eller med et element (111) anbragt inde i det andet stabiliseringselement (110), hvor det
- 20 andet fastgørelsesmiddel (65) er beregnet til at udøve en kraft på det andet stabiliseringselement (110) i retningen ind mod døren, således at den første flade (86) på det andet stabiliseringselement (110) gennem denne kraft udøver en trykkraft mod den anden plade (52) i retningen mod dørens inderside (32), således at den anden plade (52) holdes i position mod dørens inderside,
- 25 hvor enten
- a) det andet stabiliseringselement (110) har sådan en længde, at det i en monteret tilstand når en flade på låsekassen (23), som er monteret i døren, og ligger an med sin anden side (84) mod fladen på låsekassen, når det andet stabiliseringselement (110) holdes
- 30 fastgjort på døren ved hjælp af det andet fastgørelsesmiddel (65), eller

b) dørlåseindretningen omfatter mindst et afstandselement (66), som er indrettet til at være anbragt mellem den anden side (84) af det andet stabiliseringselement og låsekassen (23), som er monteret i døren, således at den side af afstandselementet, som vender mod låsekassen (23) i døren, i en monteret tilstand når en flade på låsekassen og ligger an mod denne flade, når det andet stabiliseringselement (110) holdes fastgjort på døren ved hjælp af det andet fastgørelsesmiddel (65).

5

8. Dørlåseindretning ifølge et hvilket som helst af de foregående krav, hvor den første plade (51) og den anden plade (52) ud over det første (53), andet (54), tredje (55) og fjerde (56) pladehul ikke har nogen huller positioneret således, at de er beregnet til skruer, som skal holde pladerne (51, 52) fastgjort på døren uden at strække sig til eller gennem låsekassen (23), som er anbragt i døren.

15

9. Dør (30), omfattende mindst et første dørhul (21), som strækker sig fra dørens yderside (31) til dørens inderside (32), en låsekasse (23), som er anbragt i døren i niveau med det første dørhul (21), og en låsecylinder (40), som er anbragt således, at den strækker sig fra dørens yderside (31) ind i det første dørhul (21) i retningen mod låsekassen (23), som er anbragt i døren på sådan en måde, at låsecylinderen (40) kan interagere med låsekassen (23) for at låse og oplåse låsen, hvor døren også omfatter en dørlåseindretning ifølge et hvilket som helst af de foregående krav, hvor dørlåseindretningen er monteret som beregnet på døren.

20

10. Fremgangsmåde til montering af en dørlåsekonstruktion på en dør (30), som har mindst et første dørhul (21), som strækker sig fra dørens yderside (31) til dørens inderside (32), hvilken fremgangsmåde omfatter:

25

at tilvejebringe en låsekasse (23), mindst en låsecylinder (40) og en dørlåseindretning ifølge et hvilket som helst af kravene 1-8, at anbringe låsekassen (23) i døren i niveau med det første dørhul (21), at anbringe låsecylinderen

30

(40) i den første reces (47) i den første låsecylinderbeskyttelse (41), at anbringe dørlåseindretningen som beregnet på døren.

DRAWINGS

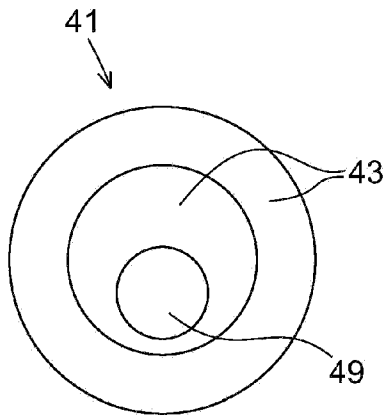

Fig. 1

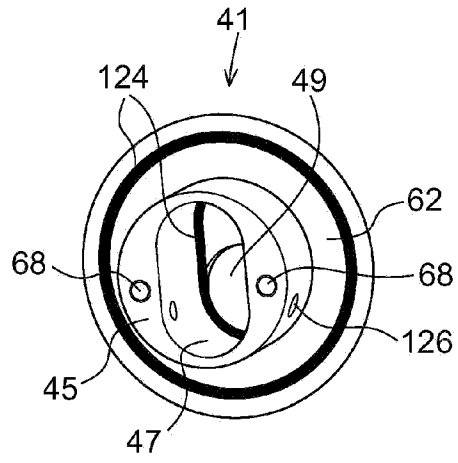

Fig. 2

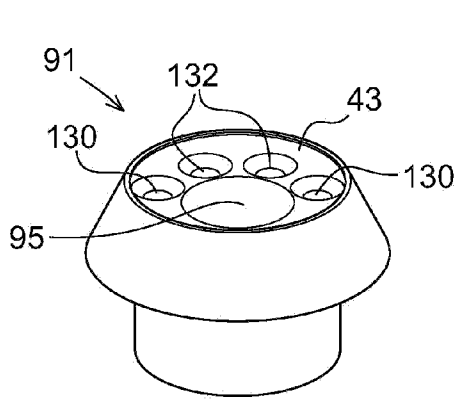

Fig. 3

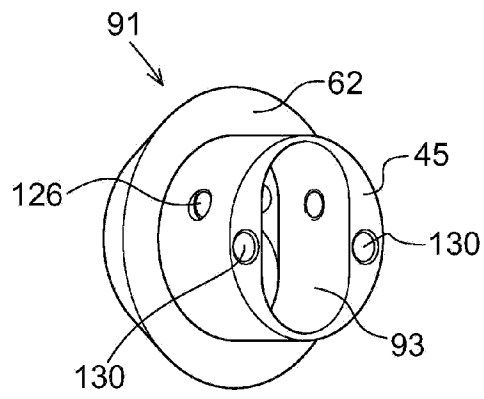

Fig. 4

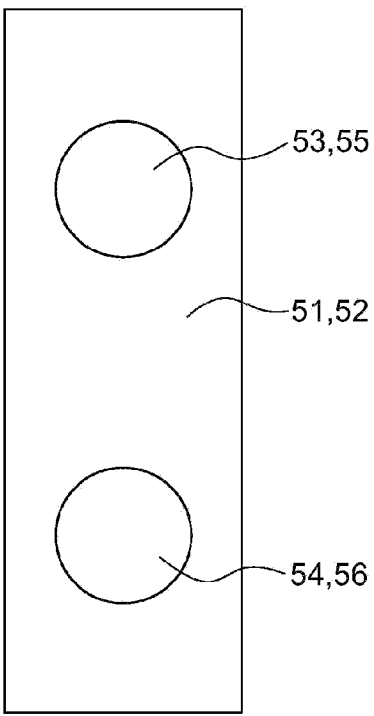
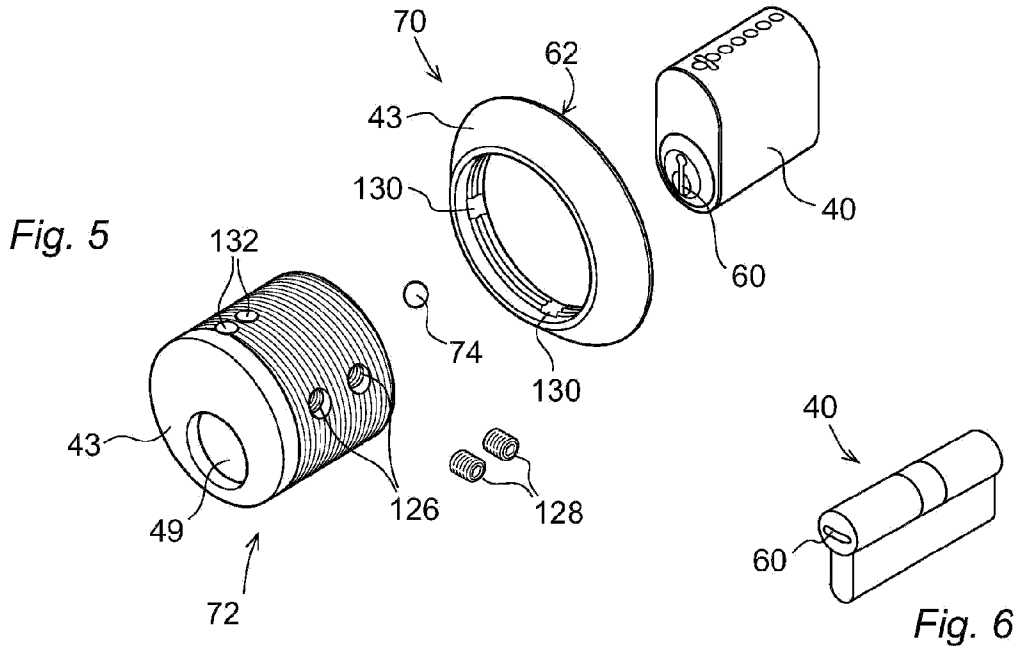

Fig. 7

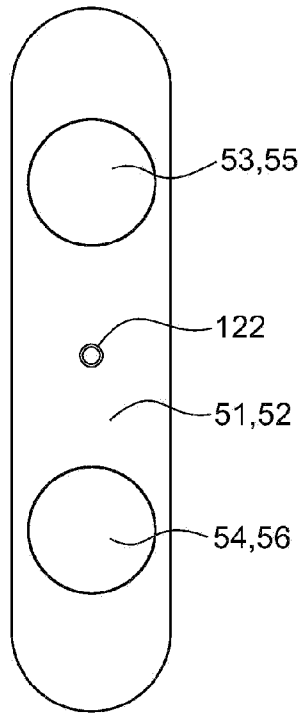

Fig. 8

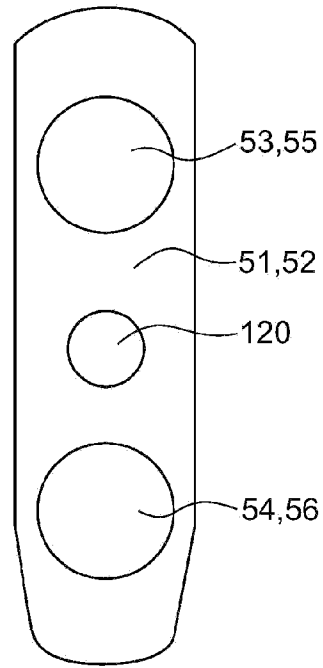

Fig. 9

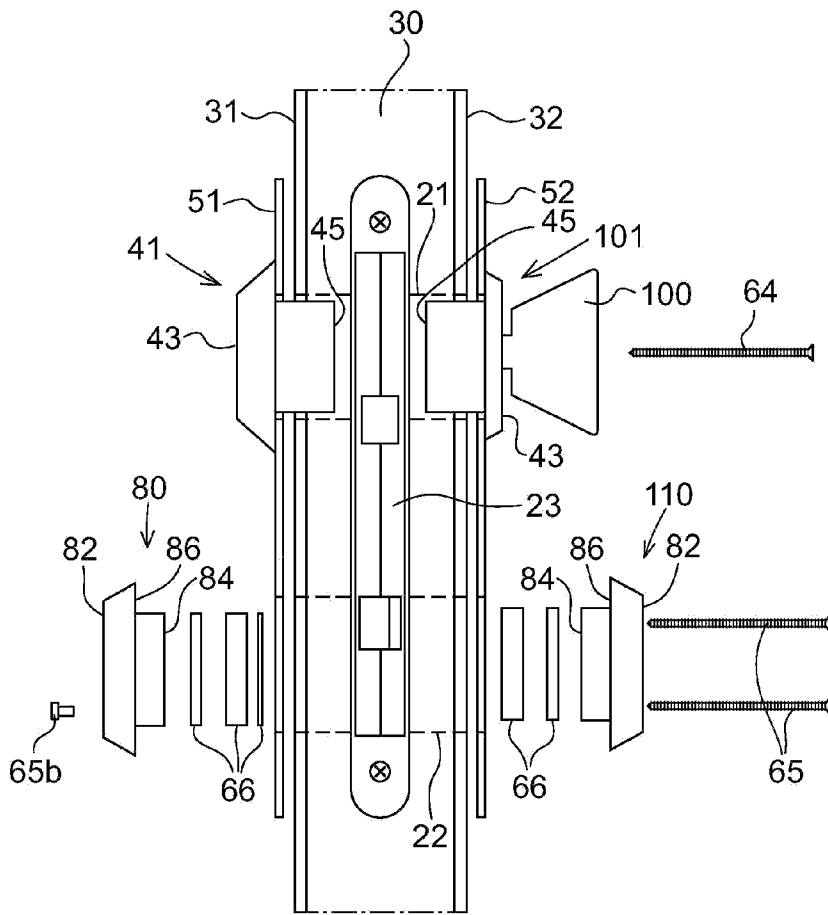

Fig. 11