

Dec. 3, 1929.

E. S. SACHSENMAIER

1,737,895

SPRAY GUN

Filed Dec. 10, 1927

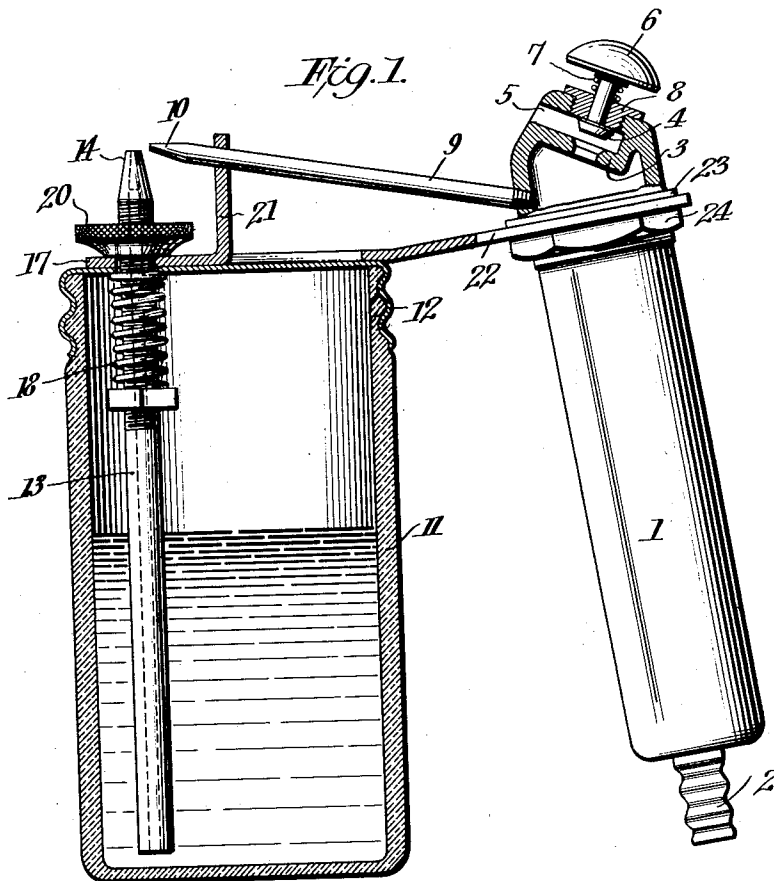

*Fig. 2.*

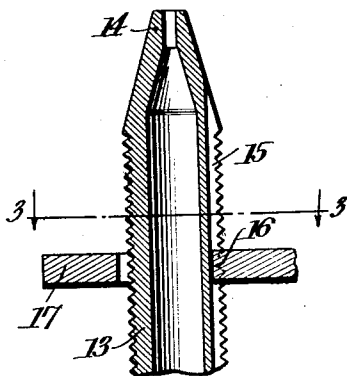

*Fig. 3.*

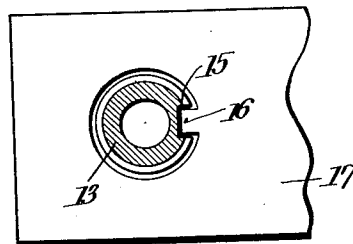

Inventor

*Ervin S. Sachsenmaier*

*By Spear, Middleton & Donaldson, Attorneys*

Attorney

# UNITED STATES PATENT OFFICE

ERVIN SAMUEL SACHSENMAIER, OF PHILADELPHIA, PENNSYLVANIA, ASSIGNOR TO  
DUNNING COMPRESSOR CO., OF PHILADELPHIA, PENNSYLVANIA, A CORPORATION  
OF PENNSYLVANIA

## SPRAY GUN

Application filed December 10, 1927. Serial No. 239,232.

This present invention relates to a device for spraying paint or other liquid materials by means of compressed air.

The principal object of the invention is the provision of a liquid supply tank and a compressed air nozzle, and conduit assemblies so arranged that the most efficient results may be secured, which will be positive in its operation and which will have no parts to get out of order.

To this end the invention consists in a device of the above type including an elongated chamber to which compressed air or other fluid is supplied, which chamber serves as the operating handle. At the head of this chamber is located a spring actuated exhaust valve adapted to be closed manually. Also in the head of the chamber is arranged a nozzle through which the compressed fluid passes when the exhaust valve is closed. The exhaust valve aperture being considerably larger than the aperture in the compressed fluid nozzle, the fluid will exhaust through the former rather than through the latter when the exhaust valve is unseated.

The liquid supply reservoir consists of a jar or the like provided with a screw cover apertured to receive the liquid or aspirator tube which extends from near the bottom of the jar through the cover and out through the top to a point in proximity to the restricted end of the compressed air nozzle. A plate carrying the elongated compressed air chamber and the nozzle is detachably secured to the liquid reservoir top.

The upper portion of the liquid supply tube is threaded and provided with a longitudinal slot or keyway in which rides a key portion of the plate carrying the compressed air chamber. This effectively prevents the liquid tube from turning.

Beneath the liquid supply reservoir cover and surrounding the liquid supply tube is a coil spring held under compression by a nut threaded to the supply tube. A similarly threaded nut is threaded to the upper portion of the liquid supply tube which projects above the plate and by adjusting this nut the restricted bore of the liquid tube may be brought into or out of proximity to the com-

pressed fluid nozzle in order to produce the desired character of spray.

The invention further consists in the novel arrangement, combination and construction of parts more fully described hereinafter and shown in the accompanying drawings, in which:—

Figure 1 is a front sectional elevation of a device embodying my invention.

Fig. 2 is a sectional detail of the supply tube.

Fig. 3 is a sectional plan along the line 3—3 of Fig. 2.

Referring now to the embodiment illustrated, I have shown the elongated compressed air chamber at 1 which serves as a handle for the device provided at its lower end with a tube 2 to which the compressed air to operate the device is supplied. The upper end of the chamber 1 is provided with an interior wall 3 having an aperture adapted to be closed by the exhaust valve 4. A port 5 communicating to the outside atmosphere permits compressed air within the chamber 1 to escape when the exhaust valve 4 is removed from its seat. The exhaust valve is provided with a button head 6 and includes a coil spring 7 which normally tends to keep the head 4 off its seat. When operating the device, the operator with his thumb depresses the button head 6, thus closing the aperture in the inner wall 3.

A screw threaded closure 8 is provided in the top of the chamber 1 which carries the shank of the exhaust valve.

Also secured in the head of the chamber 1 is the compressed fluid nozzle 9 of a diameter smaller than the diameter of the exhaust aperture. This nozzle 9 is provided with a restricted tip 10 as is customary in such constructions.

The reservoir adapted to contain the material to be sprayed may consist of a jar 11 having a screw cap 12, the cap 12 being apertured to receive the liquid supply tube 13. This last named member extends from near the bottom of the jar 11 out through the top of the cap 12 and terminates in a restricted end portion 14 in proximity to the nozzle point 10.

The tube 13 is provided with a longitudinal groove 15 in which rides the key 16 upon the plate 17 so that the supply tube is prevented from turning by these instrumentalities.

The plate 17 is secured to the top 12 of the jar 11 by solder, rivets or other suitable means. On top of the plate 17 is located the adjusting nut 20 which is held against the plate 17 by the tension of the spring 18. The face of the adjusting nut 20 is concentric with the liquid tube 13 and the tension of the spring 18 holds the face of the nut 20 against the face of the plate 17. This keeps the liquid tube 13 always perpendicular to the face of the plate 17. At the same time by moving the adjusting nut 20 the tip 14 of the supply tube may be moved up or down as desired to produce the required character of spray.

The plate 17 is provided with an upwardly bent extension 21 to receive the end of the compressed air supply nozzle 9 and a further extension 22 to which the elongated compressed air supply chamber 1 is secured by means of the flange 23 and the nut 24.

It is to be noted that by means of the instrumentalities preventing the liquid supply tube from turning and the adjusting nut 20 quick and accurate adjustment and alignment may be had and maintained between the tube tip and the compressed air nozzle. This adjustment and alignment is necessary to produce an efficient device.

In operation the jar 11 is filled with the desired liquid to be sprayed and compressed fluid supplied to the tube 2. Compressed fluid now exhausts through the port 5 and no liquid is sprayed. Upon the operator manually closing the exhaust valve 4 by depressing the button 6 compressed air must pass through the nozzle 9 and over the tip 14 of the liquid tube 13 which aspirates liquid from the jar 11 and breaks the mass into the desired character of spray depending upon the relation of the tips 14 and 10.

It is to be noted that by removing the adjusting nut 20, the liquid tube 13 may be readily and quickly detached from the device for repair or replacement. When it is desired to refill the jar 11 the cap may be removed which carrying the rest of the mechanism allows the operator to replenish his liquid supply without cumbersome parts being in his way.

What I claim is:

1. A spray gun comprising a compressed fluid chamber, a manually operated exhaust by-pass carried thereby, a compressed fluid nozzle extending from said chamber, a liquid supply tank, a liquid aspirator tube carried thereby, the tips of the compressed air nozzle and the liquid supply tube being in proximity to each other, a cap on the liquid supply tank, a spring encircling the liquid supply tube and below the cap, a nut on the tube below the spring, a plate carrying the compressed fluid chamber on top of the cap and an

adjusting nut threaded to the liquid supply tube and engaging the plate.

2. A spray gun comprising a compressed fluid chamber, a manually operated exhaust by-pass carried thereby, a compressed fluid nozzle extending from said chamber, a liquid supply tank, a liquid aspirator tube carried thereby, the tips of the compressed air nozzle and the liquid supply tube being in proximity to each other, a cap on the liquid supply tank, a spring encircling the liquid supply tube and below the cap a nut on the tube below the spring, a plate carrying the compressed fluid chamber on top of the cap and an adjusting nut threaded to the liquid supply tube and engaging the plate, a key on said plate riding in a longitudinal keyway on the liquid supply tube whereby said tube is prevented from turning movement.

3. A spraying device comprising a liquid container having a removable top, a plate secured to the top and having an integral upwardly turned lug provided with an aperture, said top and plate having coinciding apertures, an aspirating tube vertically adjustable in said apertures, said plate having an extension to one side of the container cover, a compressed air chamber removably carried by said extension and forming a handle and having a portion extended above said extension, a blast pipe connected to said portion and having its forward portion passing through said aperture and terminating adjacent the upper end of the aspirating tube, said upper portion of the compressed air chamber having an exhaust port and valve means for controlling said port.

4. A spraying device according to claim 3 in which the extension of the plate on the container top is provided with a slot to receive the compressed air chamber, and said chamber is provided with a shoulder engaging one face of the plate and a clamping nut engaging the other face.

In testimony whereof, I affix my signature.  
ERVIN SAMUEL SACHSENMAIER.

115

120

125

130