

July 21, 1953

V. R. HERTERICK
LIGHT AND SWITCH COMBINATION

2,646,477

Filed Oct. 21, 1949

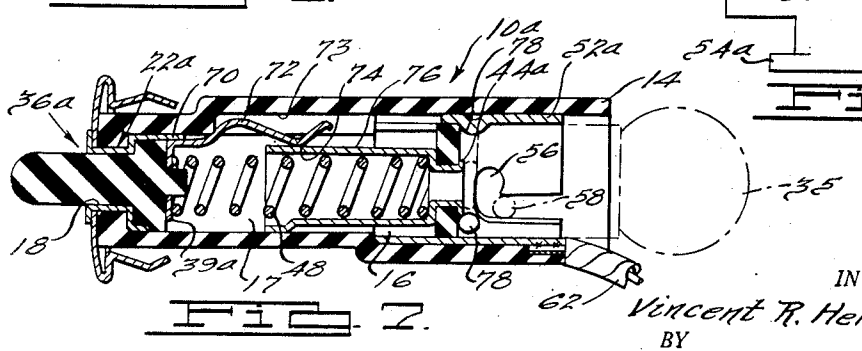
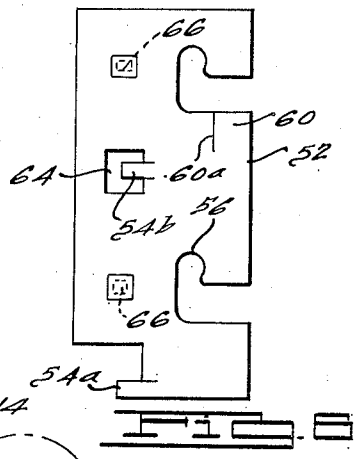
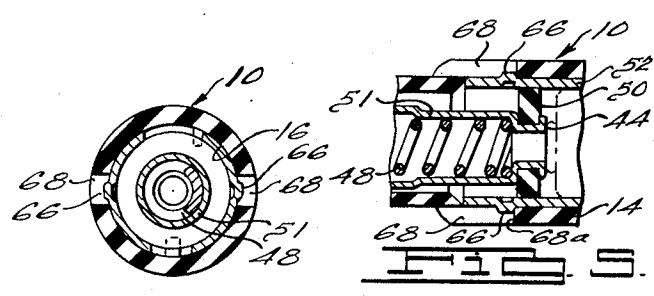
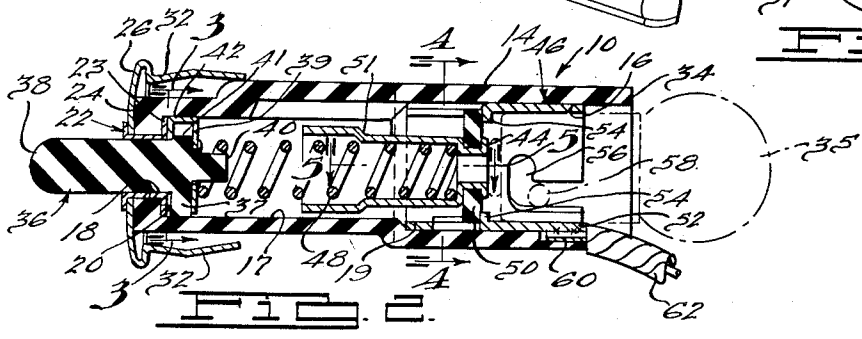
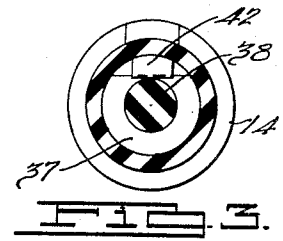
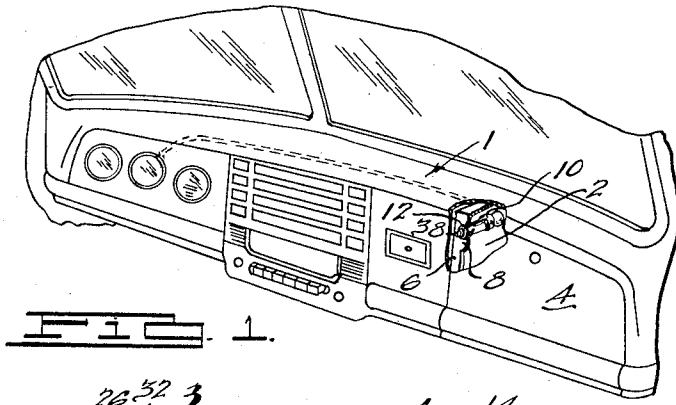

INVENTOR.
Vincent R. Herterick.
BY
Harness, Dickey & Pierce,
ATTORNEYS.

UNITED STATES PATENT OFFICE

2,646,477

LIGHT AND SWITCH COMBINATION

Vincent E. Herterick, Sturgis, Mich., assignor to
Wade Electric Products Co., Sturgis, Mich., a
corporation of Michigan

Application October 21, 1949, Serial No. 122,831

9 Claims. (Cl. 200—51.13)

1

This invention relates generally to light and switch combinations and is particularly adapted among other uses as a glove compartment light and switch for motor vehicles.

An object of this invention is to provide a new and improved light switch combination.

Another object of this invention is to provide such a combination which may be easily and simply installed.

Another object of this invention is to provide such a combination which is simple in operation and installation and which is economical of manufacture.

Other objects will be apparent from the specification, the appended claims and the drawings, in which drawings,

Figure 1 is a partial view of a motor vehicle instrument panel showing the invention;

Fig. 2 is a view in central vertical section of the switch and light combination;

Fig. 3 is a view taken substantially along the line 3—3 of Fig. 2;

Fig. 4 is a view taken substantially along the line 4—4 of Fig. 2;

Fig. 5 is a view taken substantially along the line 5—5 of Fig. 2;

Fig. 6 is a developed view of the bulb retainer; and

Fig. 7 is a view similar to Fig. 2 showing a modified form of the invention.

Referring to the drawings, the numeral 1 indicates generally the instrument panel of a motor vehicle having a glove compartment 2 adapted to be closed by means of a door 4. As is normal in most glove compartments, there is provided rearwardly of the door an end frame 6 having a gusset 8. The light-switch combination 10 is received within an aperture 12 in the gusset 8.

The light-switch combination comprises a tubular housing 14 which may be and preferably is of insulating material such as molded phenolic. Internally, the tubular member 14 comprises concentric cylindrical sections 16, 17 and 18 of progressively reduced diameter which provide at their intersections shoulders 19 and 20.

A current conducting tubular element 22 is positioned within section 18 of the tubular member 14 and has an out-turned flange 23 seating against the shoulder 20. The other end portion of the element 22 extends outwardly of the end face 24 of the tubular member 14 and through a central aperture in a snap fastener button 26. The outer end portion of the element 22 is spun outwardly to lock the flange 23 against the shoul-

2

der 20 and the button 26 against the end face 24 of the housing 14. The button 26 is provided with a plurality of peripherally spaced resilient fingers 32 which project generally in a direction toward the other end 34 of the tubular member 14 and serve to provide a resilient snap securement for releasably holding the combination 10 within the aperture 12.

The operation of the lamp 35 is controlled by a post 36 having an enlarged head 37 positioned within the cylindrical portion 17 adjacent the shoulder 20. The post 36 further has a stem 38 which extends outwardly through the element 22 externally of the housing 14 whereby it may be operated externally of the housing, as for example, by the glove compartment door 4.

An annular current conducting contact member 39 fits over a cylindrical projection 40 at the inner end of post 36. One peripheral edge portion of the head 37 is cut away as at 41 to permit a tab 42 of the contact 39 to extend along the head 37. When the post 36 is in its leftward, or switch-closed position, as shown, tab 42 engages the flange 23 of the tubular element to permit current flow therebetween, and provide a grounding connection through button 26, and frame 6.

The contact 39 is electrically connected to the central terminal 44 of a bulb receiving socket 46 by means of an electrically conducting spring 48, which has one end portion fitting over the projection 40 and engaging the contact 39. The expansive force exerted by the spring 48 acts to securely hold the contact 39 against the head 37 of the post 36, and to urge the post 36 into its circuit closing position, in which the tab 42 engages the tubular element 22.

The terminal 44 is carried within a central aperture of a movable insulating disk 50, and is provided with a cup-shaped projection 51 which extends toward the post 36 and cages the adjacent end portion of the spring 48. The disk 50 is slidably received within a sleeve 52 mounted within the section 18 of the tubular member adjacent the end 34 as by a press fit. A plurality of fingers 54 are bent inwardly from the sleeve 52 to provide stops for limiting the outward movement of the disk 50 whereby the spring 48 is always maintained under stress.

The sleeve 52 is provided with diametrically arranged J-slots 56 for cooperation with diametrically extending prongs 58 of a light bulb or lamp 35. The slots 56 are positioned relative to the fingers 54 so that when a lamp 35 is in place the lamp maintains the disk 50 away from

the fingers 54, permitting the spring 48 to hold the terminal 44 tightly against the cooperating terminal of the lamp 35. The parts are shown with the bulb 35 only partially inserted. The final inserting movement, of course, seats the prongs 58 in the J-slots, and spaces the disk 50 away from the fingers 54, as aforesaid.

The sleeve 52 is provided with an outwardly extending rebent tang 60 for connection with an electrical supply conductor 62. The tang 60 and conductor 62 are accommodated in a recess in the wall of the tubular member 14.

Referring more specifically to Fig. 6, the sleeve 52 may be made from a substantially planar sheet of metal which is apertured as by a punch press operation to provide the J-shaped slots 56 opening outwardly through one side wall thereof. As shown the left-hand lower corner of the sheet is notched out to the depth at which the fingers 54 are to be located leaving a small projection 54a which will later be bent to provide one of the fingers 54. As shown two fingers 54 are provided which are arranged diametrically with respect to each other and therefore the sheet is apertured as at 53 leaving a projecting metal piece 54b which will be bent in the same direction as the projection 54a to provide the other finger 54. In order to provide a snap entry of the sleeve 52 into the tube section 16, the sheet is provided with offset bumps 66. The tang 60 is provided by shearing the sheet along line 69a parallel to the edge through which the J slots open, and rebending the finger thus provided. The sheet is rolled into cylindrical shape with the fingers 54 extending radially inwardly and the bumps 66 and tang 60 extending outwardly. When the sleeve 52 is inserted into the slightly elastic housing 14, the bumps 66 snap behind shoulders 68a defined by recesses 68 in the walls of the section 16, and thus hold the sleeve 52 against undesired withdrawal.

As shown the conductor 62 forms one terminal of the combination 10 and the button 23 the other terminal, whereby when the button is inserted into the aperture in the metal gusset, it is connected with the grounded terminal of the motor vehicle battery (not shown). The conductor 62 is connected to an ungrounded portion of the vehicle battery. Thusly connected and with the door 4 open, an electrical circuit will be completed from the battery (not shown) through conductor 62, sleeve 52, lamp 35, terminal 44, spring 48, contact 39, tab 42, element 22, button 23, and gusset 8 to the grounded side of the battery. Upon closure of the door 4, the stem 23 is moved against the force of the spring 48 to cause the tab 42 to move away from the element 22 and break the circuit through the combination, thereby extinguishing the lamp 35.

In the form shown in Fig. 7, the tubular element 22a is provided with a projection 70 which extends beyond the head 31 and which electrically engages a projection 72 of the annular contact 39a. This projection is received within a longitudinally extending slot 73 in the wall of tubular section 17 and is formed to provide adjacent its outward end a contact portion 74 which resiliently engages the outer surface of the cup-shaped portion 76 of the terminal 44a carried by the disk 50. The sleeve 52a is similar to sleeve 52 but instead of being provided with fingers 54 is provided with inwardly deformed side wall portions to provide stops 78 arranged at 120° intervals about the sleeve to limit the movement of the disk 50 by the spring 48. With the switch ele-

mant 36a in the position shown, the portions 70 and 72 are in electrical connection to complete a circuit from the conductor 62, sleeve 52a, lamp 35, terminal 44a, portion 76, portion 74, projections 72 and 70, element 22 to button 23. Upon closure of the door 4, the switch element 36a is moved against the face of the spring 48 to move the portion 72 beyond the end of portion 70 to break the circuit through the combination 10a.

What is claimed and is desired to be secured by United States Letters Patent is as follows:

1. In a light and switch combination adapted to be inserted within and resiliently carried within a drilled hole in a current conducting member, a non-conductive tubular supporting member of a dimension which will slip through said hole, a conductive bulb retainer carried within said tubular member and opening outwardly through one end wall thereof, a switch mechanism within said tubular member and having a pair of relatively movable contacts and a non-conductive actuator, said actuator extending outwardly of the opposite end wall of said tubular member and operable to control the relative position of said contacts, a resilient conductive securement carried by said opposite end wall and electrically connected with one of said contacts and adapted upon insertion into said hole to releasably secure said tubular member to and to electrically connect said one contact to said conducting member and means electrically connecting the other of said contacts to said retainer.

2. In a combined switch and light assembly, a tubular supporting housing of electrical insulating material having a plurality of intersecting aligned cylindrical apertures forming at their intersections shoulders, a bulb retaining sleeve positioned within and snugly fitting one of said apertures and engageable with one of said shoulders to limit movement thereof in one direction relative to said housing, said sleeve having an outwardly extending protuberance receivable within a recess in a side wall of said one aperture and cooperable with a wall of said aperture to limit movement of said sleeve in a second direction relative to said housing, a switch operating member extending externally of said housing into said housing through a second of said cylindrical apertures and having a head positioned within a third of said apertures, said third aperture being positioned intermediate said one and said second apertures and of greater cross sectional area than said second aperture, a second sleeve extending throughout the length of said second aperture and having a portion external of said housing, a resilient securement having an aperture therethrough through which said operating member and said second sleeve extend, said second sleeve having a first portion seating against the one of said shoulders intermediate said second and said third apertures and having a flanged portion overlying said securement whereby said securement and said second sleeve are secured to said housing, a disk member slidably received within said retaining sleeve and provided with a contact, current conducting means carried by said switch operating member and movable thereby to positions to engage and disengage said second sleeve, and means for normally maintaining said conducting means in contact with said second sleeve and said disk member in said retainer sleeve.

3. In an electrical switch for a light bulb, the combination of a tubular non-conducting housing open at both ends, said housing including a

5

stationary conducting sleeve at one end, a non-conducting plunger slidably mounted in said sleeve and accessible from said one open end of the housing, a common ground connection and mounting member carried by the housing in electrical contact with said sleeve, a contact element carried by said plunger and electrically engageable with said sleeve when the plunger is in one position, a conducting bulb retainer sleeve having a live wire connection mounted in the other end of the housing, and means for urging the contact element and plunger toward said one position and for electrically connecting said contact element with the assembly of said bulb retainer and a bulb.

4. The invention set forth in claim 3 wherein said mounting member has a radial portion engaging the radial end surface of said housing and said sleeve has a radial flange engaging said radial portion and clamping it against said radial end surface.

5. In an electrical switch for a light bulb, the combination of a tubular non-conducting housing open at both ends, a plunger slidably mounted in one end of the housing, a contact element carried by said plunger, a terminal connection for the switch carried by the housing and electrically engaged by said contact element when said plunger is in one position, a conducting bulb-retainer sleeve having a terminal connection for the switch and mounted in the other end of the housing, a second contact element having a non-conducting periphery which is slidably mounted in said bulb retainer sleeve, said second contact element being capable of electrical contact with the assembly of said bulb retainer and a bulb, and a spring acting between said contact elements to spread them apart.

6. The invention set forth in claim 5 wherein said spring is conductive and constitutes the sole electrical connection between said contact elements.

7. The invention set forth in claim 5 including an elongated spring retainer tube containing said spring and secured to the second contact element and slidably mounted on the inside wall of the housing.

8. The invention set forth in claim 7 wherein said spring retainer tube is conductive and said first contact element includes a resilient finger

6

extending lengthwise of the housing and engaging said tube.

9. In an apparatus of the character described, a molded plastic non-conducting tubular supporting body having an aperture extending completely therethrough longitudinally from end to end, said aperture having a plurality of diameter portions providing shoulders at their intersections, a bulb retainer telescoped within and supported by the walls of the first and largest of said diameter portions and longitudinally seated against one of said shoulders to open out of one end of the body, a plunger having a head portion and a stem portion, a conducting sleeve mounted in a second and smallest diameter portion, said stem portion being slidably fitted in said sleeve and extending out of the other end of said body, said head portion being of greater width than said second diameter portion and received within a third diameter portion intermediate said first and second diameter portions and by abutment with a radial shoulder at the junction of said second and third diameter portions serving to limit outward movement of the plunger, switch means comprising a plunger operated contact of greater width than said second diameter portion engageable with said sleeve and separable from the sleeve by inward movement of the plunger, terminals connected respectively to said sleeve and bulb retainer, and current conducting means within said third diameter portion interconnecting said contact and said bulb retainer, said retainer, sleeve, plunger, contact, and means all being of less width than said first diameter portion and therefore insertable into said body through said one end.

VINCENT R. HERTERICK.

References Cited in the file of this patent
UNITED STATES PATENTS

Number	Name	Date
730,567	Plassmann	June 9, 1903
1,411,947	Whittington	Apr. 4, 1922
1,485,932	Kerwin	Mar. 4, 1924
2,067,077	Edwards	Jan. 5, 1937
2,223,673	Catron et al.	Dec. 3, 1940
2,271,910	Bluemle	Feb. 3, 1942
2,338,481	Batcheller	Jan. 4, 1944
2,418,905	Sage	Apr. 15, 1947