

J. W. LATTA.
RAILWAY SIGNAL APPARATUS.
APPLICATION FILED SEPT. 28, 1906.

2 SHEETS—SHEET 1.

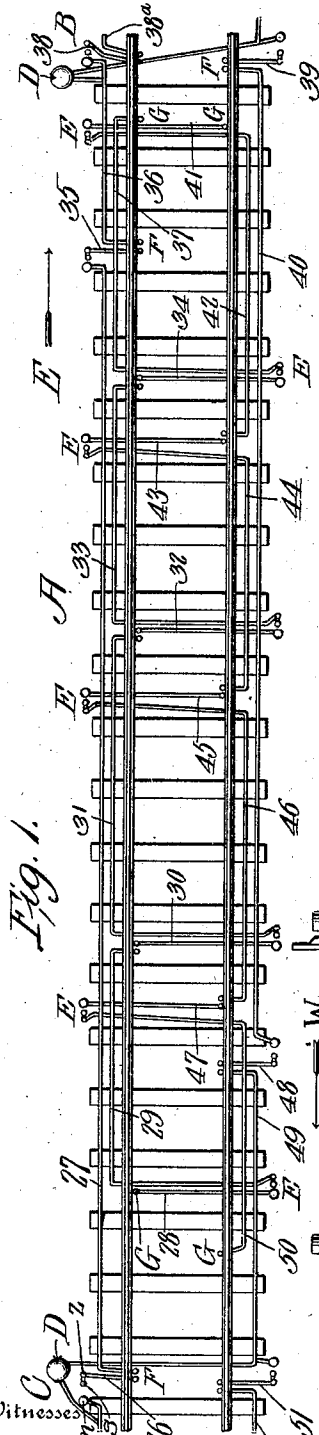

Witness
C. W. Holmes
W. C. Stealy

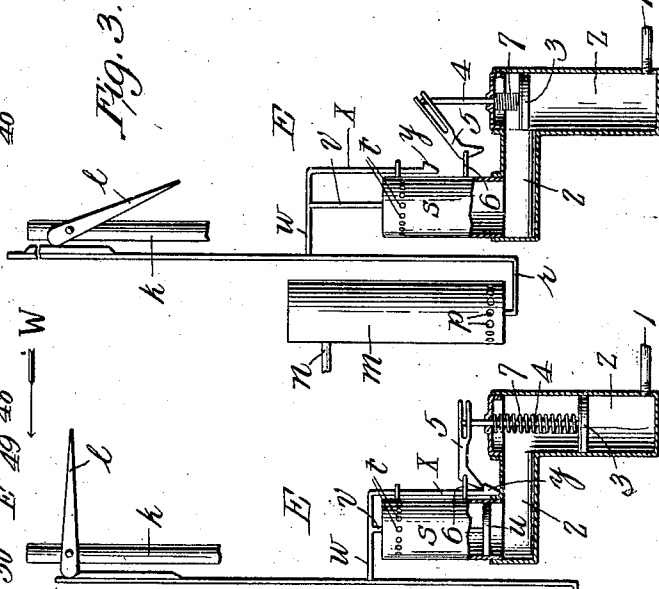
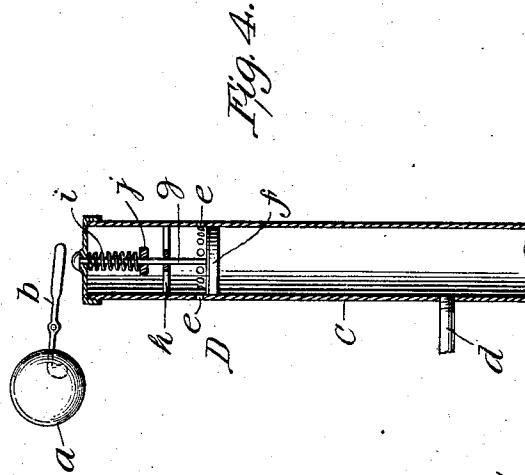

Inventor
J. W. Latta.
 Attorney
James J. Shuey

J. W. LATTA.
RAILWAY SIGNAL APPARATUS.
APPLICATION FILED SEPT. 28, 1906.

2 SHEETS—SHEET 2.

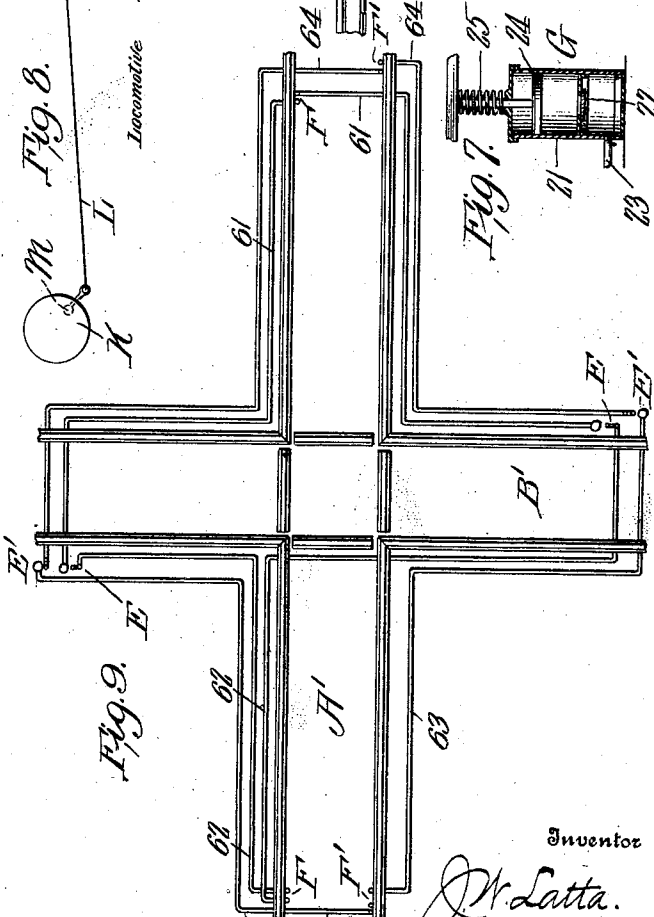
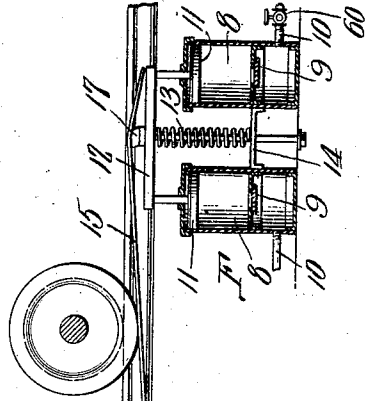
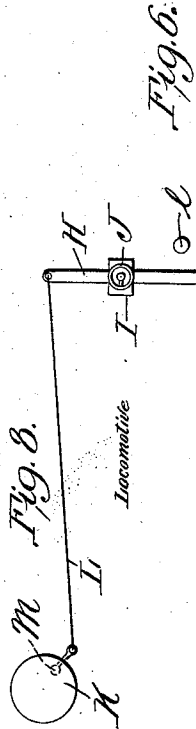
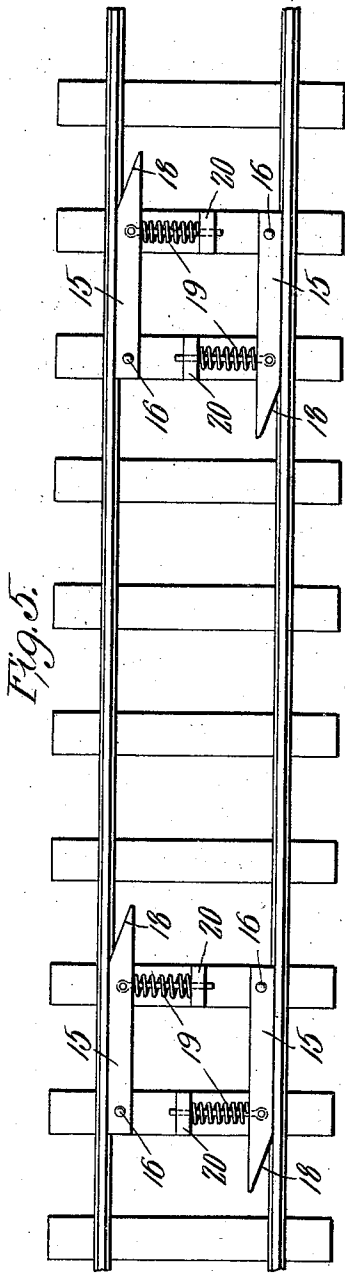

Witnesses

R. W. Holmes
W. C. Stealy

334

Inventor
J. W. Latta.
James Shuey
Attorney

UNITED STATES PATENT OFFICE.

JOSHUA W. LATTA, OF MELVERN, KANSAS.

RAILWAY SIGNAL APPARATUS.

No. 842,675.

Specification of Letters Patent.

Patented Jan. 29, 1907.

Application filed September 28, 1906. Serial No. 336,587.

To all whom it may concern:

Be it known that I, JOSHUA W. LATTA, a citizen of the United States, residing at Melvern, in the county of Osage and State of Kansas, have invented new and useful Improvements in Railway Signal Apparatus, of which the following is a specification.

My invention relates to railway signal apparatus; and it has for one of its objects to provide a pneumatic apparatus through the medium of which a train automatically raises signals in front of and behind it with a view of avoiding head-on and rear-end collisions and automatically lowers the said signals when it has passed a safe distance beyond the same.

Another object of the invention is the provision of a reliable pneumatic apparatus for raising and lowering signals adjacent to the point where two railways cross each other, this with a view of apprising an engineer traveling on one railway of the fact when a train is approaching the crossing on the other railway and of also informing the engineer when there is no train on the other railway in dangerous proximity to the crossing.

Another object is the provision of means on a locomotive arranged to be engaged by the signals set against said locomotive, this in order to inform the engineer in an audible or other suitable manner that the signals are set against him—*i. e.*, are raised.

With the foregoing in mind the novelty, utility, and practical advantages of the various parts of my invention will be fully understood from the following description and claims when the same are read in connection with the accompanying drawings, forming part of this specification, in which—

Figure 1 is a diagrammatic view illustrating a block of railway equipped with my pneumatic signal apparatus. Fig. 2 is a view, partly in elevation and partly in section, showing one of the signals and the mechanism for raising and lowering the signal, the signal in this instance being illustrated in its raised position. Fig. 3 is a similar view with the signal lowered. Fig. 4 is an enlarged detail view of one of the audible signals which I prefer to employ in the stations at the ends of the block illustrated in Fig. 1. Fig. 5 is a detail plan view illustrating the shoes on which the flanges of the car-wheels operate to depress the pistons of the air-pumps. Fig. 6 is a detail vertical section illustrating the pumps and the shoe comple-

mentary thereto and a wheel of a car, the said wheel being shown in the position where it begins to depress the shoe, and consequently the pistons of the pumps. Fig. 7 is a view similar to Fig. 6, showing one of the single pumps employed and the appurtenances thereof. Fig. 8 is a detail view showing a portion of the locomotive and the mechanism thereon for coöperating with the raised signals and informing the engineer when the signals are raised against him. Fig. 9 is a diagrammatic view illustrating a railway-crossing and the embodiment of my invention for informing an engineer on either railway when the other railway is clear and also when a train is on such other railway in dangerous proximity to the crossing.

Referring by letter and numeral to the said drawings, and more particularly to Figs. 1 to 8 thereof, A, Fig. 1, is a block of railway. B is a station at the eastern end of the said block, and C is a station at the western end of the block, the block being one mile or a greater or less distance in length, in the discretion of the party who installs the apparatus. D D are audible signals, one of which is employed at each station. These audible signals are identical in construction, and therefore a detailed description of the one shown in Fig. 4 will suffice to impart a definite understanding of both. The said signal, Fig. 4, comprises a gong *a*, a hammer-lever *b*, a cylinder *c*, having an inlet *d* for the admission of air under pressure and also having vents *e* for the escape of air after the same has moved the piston, presently described, the said piston *f*, which has a rod *g* guided in a spider *h* in the cylinder and extending through one end of the cylinder in position to strike the lever *b*, and a coiled spring *i*, interposed between the said end of the cylinder and an enlargement *j* on the piston-rod and having for its function to return the piston to and normally hold the same in the position shown in Fig. 4.

It will be apparent from the foregoing that when air and pressure is supplied to the cylinder *c* through the port *d* the piston *f* will be forced upward, so as to rock the lever *b* and cause the latter to strike the gong, and it will also be apparent that after the piston passes the vents *e* the air will pass out of the cylinder through said vents, after which the spring *i* will return the piston to the position illustrated, where it is ready for another operation.

E E represent the signals which I employ

and the mechanisms for raising the signals, securing the signals in their raised positions, and lowering the signals. Each signal and its mechanism E is identical with every other
 5 signal and mechanism E, and for this reason a detailed description of the signal and complementary mechanism shown in Figs. 2 and 3 will suffice to impart a definite understanding of all. The said device, Figs. 2 and 3,
 10 comprises a post *k*, a semaphore signal-arm *l*, fulcrumed at an intermediate point of its length on the post and arranged to swing vertically, a piston-cylinder *m*, arranged vertically and having an inlet-port *n* for air under pressure in its upper portion and also
 15 having air-vent apertures *p* adjacent to its lower end, a piston *q*, movable in said cylinder, a piston-rod *r*, which extends downward from the piston and then laterally and then
 20 upwardly and is connected to the short portion of the signal-arm *l*, a cylinder *s*, arranged parallel to the cylinder *m* and having air-vent apertures *t* in its upper portion, a piston *u*, movable in the cylinder *s*, a rod *v*, connected
 25 to and movable with the piston *u*, an arm *w*, extending laterally from the upwardly-extending portion of the piston-rod *r* and connected to the piston-rod *v*, a latch-bar *x*, connected to the arm *w* and guided on the side of
 30 cylinder *s* and having a beveled head *y* at its lower end, a cylinder *z*, having an inlet-port 1 for air under pressure and also having its upper portion connected by a lateral conduit 2 to the lower end of the cylinder *s*, a piston 3,
 35 movable in cylinder *z* and having a rod 4 extending through the upper end of said cylinder, and a latch-lever 5, fulcrumed in a bracket 6 on the cylinder *s* and arranged, as shown in Fig. 2, to engage the head *y* of the
 40 latch-bar *x*. A spring 7 is preferably employed for returning the piston 3 to its normal position subsequent to the passage of the air under pressure from the cylinder *z* to the conduit 2. To raise or set the signal-arm *l*,
 45 air under pressure is admitted to the cylinder *m* through the port *n*, when such air will obviously force the piston *q* downward beyond the vent-apertures *p* and by so doing will raise the signal-arm *l* to the position shown in
 50 Fig. 2. The latch-bar *x* and the piston *u* will obviously move downward with the piston *q*, and the head of the latch-bar *x* will be engaged and held by the latch-lever 5, and in this way the signal-arm *l* will be locked in its
 55 raised or set position. To lower the signal-arm *l* to the safety position, air under pressure is let into the cylinder *z* through the port 1. This air will first raise the piston 3 to disengage the latch-lever 5 from the head of the
 60 latch-bar *x* and will then pass through the conduit 2 and raise the piston *u*, with the result that the short portion of the signal-arm *l* will be moved upward and the major portion of said arm will be swung downward. When
 65 the piston *u* is moved upward, as stated, the

piston *q* will also be moved upward. The piston 3, however, will by virtue of the spring 7 be lowered to the position shown in Fig. 2, so as to enable the latch-lever 5 to engage the
 70 latch-bar *x* when the latter is moved downward incident to the raising of the signal-arm *l*.

F F represent the double pumps of the apparatus and the appurtenances thereof, and G G represent the single pumps and their appurtenances. One of the double pumps is shown in Fig. 6, and, as will be readily understood, it comprises parallel cylinders 8, having non-return valves 9 and also having discharge-conduits 10, pistons 11, movable in
 80 the cylinders 8 above the non-return valves, a cross-head 12, connecting the rods of said piston, a coiled spring 13, interposed between said cross-head and a fixed lower abutment 14 and having for its function to return the
 85 pistons 11 to and normally hold the same in the position shown, and a vertically and laterally swinging shoe 15, pivoted at 16 adjacent to the inner side of one of the rails, Fig. 5, and arranged over a protuberance 17 on
 90 the upper side of the cross-head 12. The shoe 15 is provided, as shown in Fig. 5, with a beveled end 18 and is normally held under yielding pressure against the inner side of the rail by a coiled spring 19, which is interposed
 95 between the side of the shoe remote from the rail and a fixed abutment 20. In virtue of this provision it will be seen that a train traveling toward the left in Fig. 5 will not depress the shoe 15 and operate the air-
 100 pumps, because the flanges of the car-wheels will strike the beveled end 18 of the shoe 15 and will press said shoe laterally inward and away from the rail. When, however, a train moves toward the right in Fig. 5, the flanges
 105 of its wheels will ride over the shoe 15 and by so doing will depress the shoe and the pistons 11, so as to force charges of air under pressure past the non-return valves 9 and through the conduits or pipes 10. In Fig. 5 several
 110 of the shoes 15 are illustrated, and those of the shoes which have their beveled ends toward the right are designed to be depressed by the flanges of the wheels on a train moving toward the right, while those of the shoes
 115 which have their beveled ends toward the left are designed to be depressed by the flanges of the wheels on a train moving toward the left. From this it follows that a train moving in one direction will depress two of the
 120 shoes shown in Fig. 5 and will pass idly by the other two shoes.

All of the single pumps G employed are identical in construction, and therefore a detailed description of the one shown in Fig. 7
 125 will suffice to impart a complete understanding of all. The said pump G, Fig. 7, comprises a cylinder 21, having a non-return valve 22 and also having a discharge-pipe 23, a piston 24, movable in the cylinder above the
 130

non-return valve and having a rod extending through the upper end of the cylinder and disposed under a shoe 15, similar to those before described, and a coiled spring 25, interposed between the cylinder and an enlargement on the upper portion of the piston-rod and having for its function to return the piston to and normally retain the same in the position shown in Fig. 7.

10 In Fig. 1 I have illustrated in a diagrammatic manner the audible signals D, the signal devices E, the double pumps F, and the single pumps G, and by reference to said figure it will be seen that a train traveling
15 eastward—*i. e.*, from the station C toward the station B—will operate the signal apparatus as follows, viz: First, said train will depress the pistons of the first double pump F
20 and by so doing will force air through pipe 26 into the cylinder *z* of the first signal device E at the left of the train to lower the previously-raised arm *l* thereof and will also force air through a pipe 27 into the cylinder
25 *m* of the second signal device E at the left of the train to raise the arm *l* thereof; second, said train will depress the piston of the first single pump G and will force air through a
30 pipe 28 into the cylinder *m* of the first signal device E at the right of the train to raise the signal-arm *l* thereof; third, the train will depress the pistons of the second double
35 pump F and by so doing will force air through a pipe 29 into the cylinder *z* of the first signal device E at the right of the train to lower the signal-arm *l* thereof and will also force air through a pipe 30 into the cylinder
40 *m* of the second device E at the right of the train to raise the arm *l* of said device; fourth, the train will depress the pistons of the third double pump, and consequently will force air through a pipe 31 into the cylinder
45 *z* of the second device E at the right of the train to lower the arm *l* thereof and will also force air through a pipe 32 into the cylinder *m* of the third device E at the right of the train to raise the arm *l* thereof; fifth, the train will depress the pistons of the fourth
50 double pump F and by so doing will force air through a pipe 33 into the cylinder *z* of the third device E at the right of the train to lower the arm *l* thereof and will also force air through a pipe 34 into the cylinder *m* of the fourth device E at the right of the train to raise the arm *l* thereof; sixth, the train
55 will depress the pistons of the fifth double pump F, and hence will force air through a pipe 35 into the cylinder *z* of the second device E at the left of the train to lower the arm *l* thereof and will also force air through a
60 pipe 36 into the cylinder *m* of the third device E at the left of the train, which latter device E is slightly in advance of station B, to raise the arm *l* thereof and at the same time sound the audible signal D of the station; seventh, the train will depress the piston of the second

single pump G and in that way force air through a pipe 37 into the cylinder *z* of the fourth device E at the right of the train to lower the arm *l* of said device; eighth, the train as it passes to the next block will depress the pistons of the sixth double pump,
70 this to force air through a pipe 38 into the cylinder *z* of the third device E at the left of the train, so as to lower the arm *l* of said device, and at the same time force air
75 through a pipe 38^a to the cylinder *m* of the second device E at the left of the train in the next block to raise the arm *l* of the latter device. From this it follows that *en route* between the stations C and B the east-bound
80 train will raise two signals, one after the other, in front of it to warn the engineer of a train traveling in the opposite direction and will raise four signals, one after the other, behind it to warn the engineer of a following
85 train. It also follows that the train will lower the signals at its left as it reaches the same and will lower each of the rear signals when it has progressed to a predetermined safe point in advance of the same.

90 A train traveling westward—*i. e.*, from the station B toward the station C—will operate the signal apparatus in the following manner, to-wit: First, said train will depress the pistons of its first double pump F and in
95 that way will force air through pipe 39 into the cylinder *z* of the first signal device E at the left of the train to lower the previously-raised arm *l* thereof and will also force air through a pipe 40 into the cylinder *m* of the second signal device E at the left of the train
100 to raise the arm *l* thereof; second, said train will depress the piston of its first single pump G and will force air through a pipe 41 into the cylinder *m* of the first signal device E at the right of the train to raise the signal-arm *l* thereof; third, the train will depress the pistons of its second double pump F and in that way will force air through a pipe 42 into the
105 cylinder *z* of the first signal device E at the right of the train to lower the signal-arm *l* thereof and will also force air through a pipe 43 into the cylinder *m* of the second device E at the right of the train to raise the arm *l* of said device; fourth, the train will depress
110 the pistons of its third double pump F and will thereby force air through a pipe 44 into the cylinder *z* of the second device E at the right of the train to lower the arm *l* thereof and will also force air through a pipe 45 into the cylinder *m* of the third device E at the right of the train to raise the arm *l* thereof; fifth, the train will depress the pistons of its fourth double pump F and by so doing will force air through a pipe 46 into the cylinder
115 *z* of the fourth device E at the right of the train to lower the arm *l* thereof, and will also force air through a pipe 47 into the cylinder *m* of the fourth device E at the right of the train to raise the arm *l* thereof; sixth, 130

the train will depress the pistons of its fifth double pump F, and hence will force air through a pipe 48 into the cylinder *z* of the second device E at the left of the train to lower the arm *l* thereof and will also force air through a pipe 49 into the cylinder *m* of the third device E at the left of the train, which latter device E is slightly in advance of station C, to raise the arm *l* thereof and at the same time sound the audible signal D of the station; seventh, the train will depress the piston of its second single pump G and in that way force air through a pipe 50 into the cylinder *z* of the fourth device E at the right of the train to lower the arm *l* of said device. eighth, the train as it passes to the next block will depress the pistons of the sixth double pump and will force air through a pipe 51 into the cylinder *z* of the third device E at the left of the train to lower the arm *l* of said device and at the same time will force air to the cylinder *m* of the second device E at the left of the train in the next block through a pipe 52 to raise the arm *l* of the latter device. Because of the operation just described it will be seen that *en route* between the stations B and C the westbound train will raise two signals, one after the other, in front of it to warn the engineer of an eastbound train and will raise four signals, one after the other, behind it to warn the engineer of a following westbound train. It also follows that the train will lower the signals at its left as it reaches the same and will also lower each of the rear signals when it has progressed to a predetermined safe point in advance of the same.

With a view of apprising the engineers of the locomotives employed of the fact when the arms *l* of the signal devices E are set against them, I provide each of the locomotives with the mechanism shown in Fig. 8. This mechanism comprises a lever H, fulcrumed at an intermediate point of its length on a support I, extending laterally from the right-hand side of the locomotive, a spring J for normally holding the lever in and returning the same to the upright position shown, a gong K, located in the locomotive-cab, and a cable L, connecting the hammer M of the gong with the upper arm of the lever H. In virtue of this construction it will be seen that when a signal-arm *l* is raised in the path of the lever H the lower arm of the lever will be engaged and swung rearward by the signal-arm *l* with the result that the upper arm of said lever H will be moved forward and drawing on the cable L will cause the hammer M to strike the gong K. In this way the engineer will know that the signal is set against him when he fails because of darkness or fog to see the signal.

While I prefer to employ the locomotive mechanism described in the foregoing, I do

not desire to be understood as confining myself to the same, as any locomotive mechanism for serving the purpose stated may be used, or else the locomotive mechanism may be altogether omitted without involving departure from the scope of my invention.

When deemed desirable, the pipes leading from the several air-pumps F and G of the apparatus may be provided adjacent to the pumps with vent-cocks, which may be opened to prevent the pumps from actuating the signal devices E. I have shown one of these cocks in Fig. 6 and have numbered the same 60, but have deemed it unnecessary to illustrate more than one, inasmuch as said cocks are not essential to the successful operation of the apparatus.

In Fig. 9 I have illustrated an embodiment of my invention as applied at the crossing of two railways. In this embodiment A' and B' are the intersecting railways. E E are signal devices similar to that shown in Figs. 2 and 3, arranged adjacent to the railway B' and at opposite sides of and at suitable distances from the crossing. F F are double pumps similar to that shown in Fig. 6 and arranged to be operated by a train traveling on railway A' toward the left. 61 61 are pipes connecting the cylinders of the pump F at the right and the cylinders *m* of the signal devices E, and 62 62 are pipes connecting the cylinders of the pump F at the left and the cylinders *z* of the said devices E. By virtue of this construction it will be seen that as a train traveling toward the left on railway A' approaches the crossing it will operate the pump F at the right, and thereby raise or set the arms *l* of the signal devices E to warn an engineer approaching the crossing from either direction on the other railway, and it will also be seen that after the said train passes over the crossing it will operate the pump F at the left to force air into the cylinders *z* of the signal devices E and in that way lower the arms *l* of said devices. For the purpose of warning an engineer of a train on railway B' against a train traveling toward the right on railway A', I provide the signal device E', similar to the device E shown in Figs. 2 and 3, pumps F', similar to the pump F of Fig. 6, arranged to be operated by a train traveling toward the right on railway A', pipe 63 connecting the cylinders of the pump F' at the left of Fig. 6 and the cylinders *m* of the signal devices E', and pipes 64 connecting the cylinders of the pump F' at the right of Fig. 6, and the cylinders *z* of the signal devices E'.

It will be gathered from the foregoing that trains traveling in either direction on the railway B' are protected against trains traveling in either direction on the railway A', and it will be apparent that by duplicating the apparatus—*i. e.*, providing the necessary

pumps F and F' in railway B' the signal devices E and E', adjacent to railway A', and the necessary pipe connections—trains traveling in either direction on the railway A may be protected against trains traveling in either direction on the railway B'.

It will be appreciated from the foregoing that my automatic pneumatic signal apparatus is reliable in operation, is inexpensive in construction, and is not liable to be impaired by rough usage or by exposure to the weather.

The construction herein shown and described constitutes the present and preferred embodiment of my invention; but I desire it understood that in practice such changes in the form, construction, and relative arrangement of parts may be made as fairly fall within the scope of my invention as claimed.

Having described my invention, what I claim, and desire to secure by Letters Patent, is—

1. In a railway signal apparatus, a signal comprising an arm, piston-cylinders, a piston movable in one cylinder, a connection intermediate the piston and the arm for raising the latter when fluid-pressure is let into the cylinder, a piston movable in the other cylinder, and a connection intermediate the latter piston and the arm for lowering the arm when fluid-pressure is let into the last-mentioned cylinder.

2. In a railway signal apparatus, a signal comprising an arm, a piston-cylinder, a piston movable in said cylinder, a connection intermediate said piston and the arm for raising the arm when fluid-pressure is let into the cylinder, a second cylinder, a piston movable in said cylinder, a connection between said piston and the arm for lowering the latter when fluid-pressure is let into the second cylinder, a third cylinder, a conduit intermediate the third cylinder and the second cylinder for supplying fluid-pressure to the latter, a piston movable in the third cylinder and controlling the supply of fluid-pressure to the second cylinder, and means controlled by the piston in the third cylinder for locking the arm in its raised position.

3. In a railway signal apparatus, a signal comprising an arm, a piston-cylinder, a piston movable in said cylinder, a connection intermediate said piston and the arm for raising the arm when fluid-pressure is let into the cylinder, a second cylinder, a piston movable in said cylinder, a connection between said piston and the arm for lowering the latter when fluid-pressure is let into the second cylinder, a third cylinder, a conduit intermediate the third cylinder and the second cylinder for supplying fluid-pressure to the latter, a piston movable in the third cylinder and controlling the supply of fluid-pressure to the

second cylinder, a catch connected with the arm, and a latch connected with the piston in the third cylinder and arranged to engage the said catch when the arm is raised.

4. In a railway signal apparatus, a signal comprising an arm, an upright piston-cylinder having an inlet for fluid-pressure adjacent to its upper end and a vent adjacent to its lower end, a piston movable in said cylinder, a connection intermediate the piston and the arm for raising the arm when the piston is moved downward, a second upright piston-cylinder having an inlet for fluid-pressure adjacent to its lower end and a vent adjacent to its upper end, a piston movable in the latter cylinder, and a connection intermediate said piston and the arm for lowering the arm when the piston is moved upward.

5. In a railway signal apparatus, a signal comprising an arm, an upright piston-cylinder having an inlet for fluid-pressure adjacent to its upper end and a vent adjacent to its lower end, a piston movable in said cylinder, a connection intermediate the piston and the arm for raising the arm when the piston is moved downward, a second upright piston-cylinder having an inlet for fluid-pressure adjacent to its lower end and a vent adjacent to its upper end, a piston movable in the latter cylinder, a connection intermediate said piston and the arm for lowering the arm when the piston is moved upward, a third piston-cylinder, a conduit connecting said third cylinder and the inlet of the second cylinder, a piston movable in the third cylinder and controlling the supply of fluid-pressure to the second cylinder, and means controlled by said piston for locking the arm in its raised position.

6. In a railway signal apparatus, a signal comprising an arm, an upright piston-cylinder having an inlet for fluid-pressure adjacent to its upper end and a vent adjacent to its lower end, a piston movable in said cylinder, a connection intermediate the piston and the arm for raising the arm when the piston is moved downward, a second upright piston-cylinder having an inlet for fluid-pressure adjacent to its lower end and a vent adjacent to its upper end, a piston movable in the latter cylinder, a connection intermediate said piston and the arm for lowering the arm when the piston is moved upward, a third piston-cylinder, a conduit connecting said third cylinder and the inlet of the second cylinder, a piston movable in the third cylinder and controlling the supply of fluid-pressure to the second cylinder, a catch connected with the arm, and a latch controlled by the piston in the third cylinder for engaging said catch when the arm is raised.

7. In a railway signal apparatus, the combination of a track, a vehicle movable there-

on, a signal comprising an arm, a cylinder, a piston in the cylinder, a connection between the piston and the arm for raising the latter when fluid-pressure is let into the cylinder, a second cylinder, a piston therein, a connection between the latter piston and the arm for lowering the arm when fluid-pressure is let into the second cylinder, pumps arranged at intervals in the length of the track and arranged to be actuated by the passage of vehicle-wheels thereover, and conduits intermediate the discharges of the pumps and the inlets of the cylinders of the signal.

8. In a railway signal apparatus, the combination of a track, a vehicle movable thereon, signals arranged at intervals in the length of the track and respectively comprising an arm, cylinders, a piston in one cylinder, connected with the arm and arranged when fluid-pressure is let into the cylinder to raise the arm, and a piston in the other cylinder, connected with the arm and arranged when fluid-pressure is let into the cylinder to lower the arm, pumps arranged at intervals in the length of the track and respectively comprising a cylinder, a reciprocatory piston movable in the cylinder, and a shoe arranged to depress the piston of the pump and being movable vertically and horizontally and

adapted to be depressed by a vehicle-wheel moving in one direction and to be moved laterally out of the way by a vehicle-wheel traveling in the opposite direction; some of the shoes being disposed in one direction and others in the opposite direction, and conduits intermediate the discharges of the pumps and the inlets of the cylinders comprised in the signals.

9. In a railway signal apparatus, the combination of a track, signals arranged at intervals in the length of the track, air-pumps arranged at intervals in the length of the track and arranged to be actuated by the passage of a vehicle thereover, audible signals at the ends of a block of track, and connections intermediate the pumps and the signals, whereby a vehicle traveling in either direction on the track is enabled to raise signals in front and behind it and sound an audible signal in front of it and is also enabled to lower signals behind it.

In testimony whereof I have hereunto set my hand in presence of two subscribing witnesses.

JOSHUA W. LATTA.

Witnesses:

M. D. WARNER,
C. V. BOYLES.