

Aug. 2, 1966

N. H. BELL

3,263,333

CIRCULAR TEMPLATE FOR ENGRAVING MACHINES AND THE LIKE

Filed April 6, 1964

2 Sheets-Sheet 1

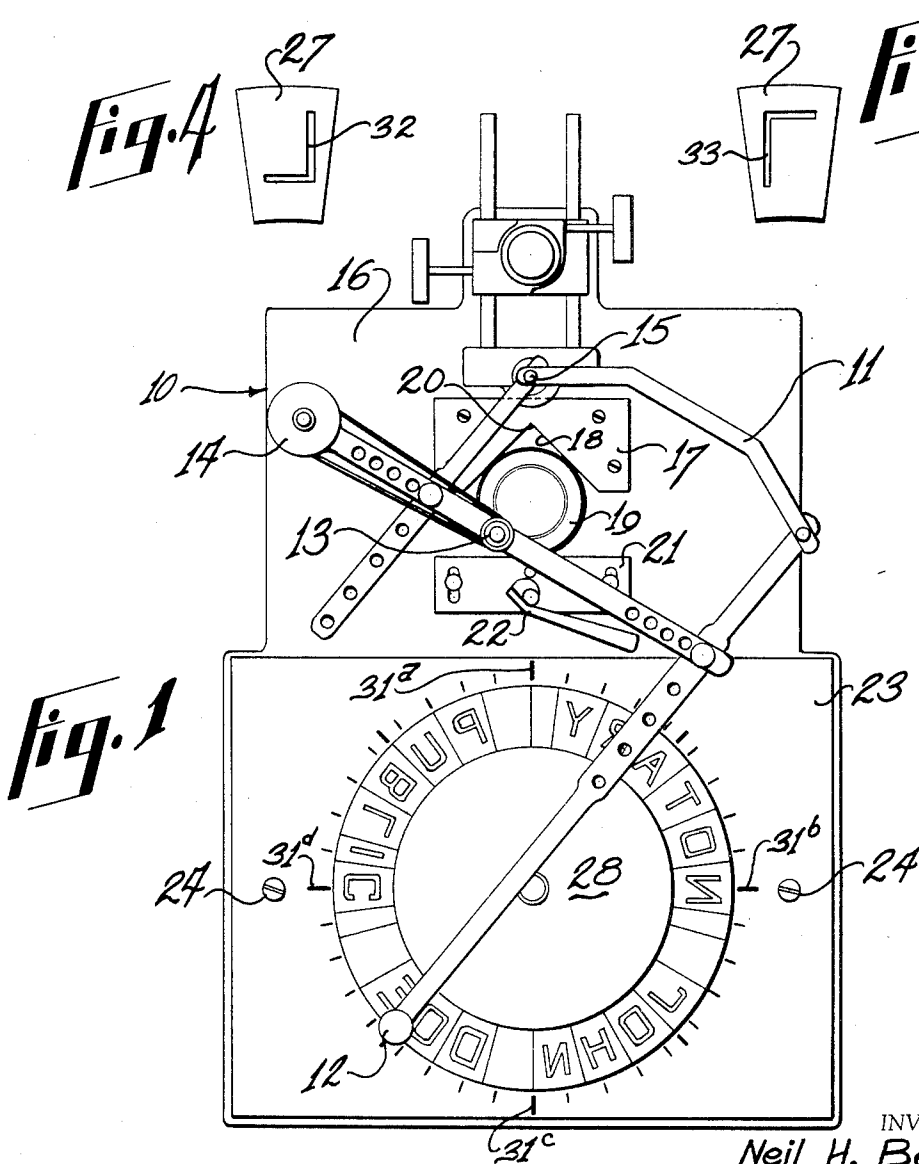
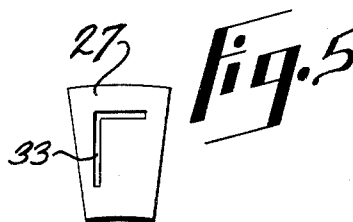
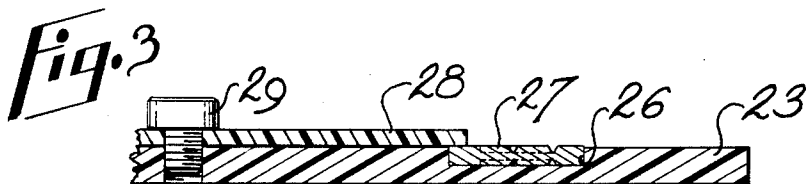

INVENTOR.

Neil H. Bell

BY

Jerming Carter & Thompson  
Attorneys

Aug. 2, 1966

N. H. BELL

3,263,333

CIRCULAR TEMPLATE FOR ENGRAVING MACHINES AND THE LIKE

Filed April 6, 1964

2 Sheets-Sheet 2

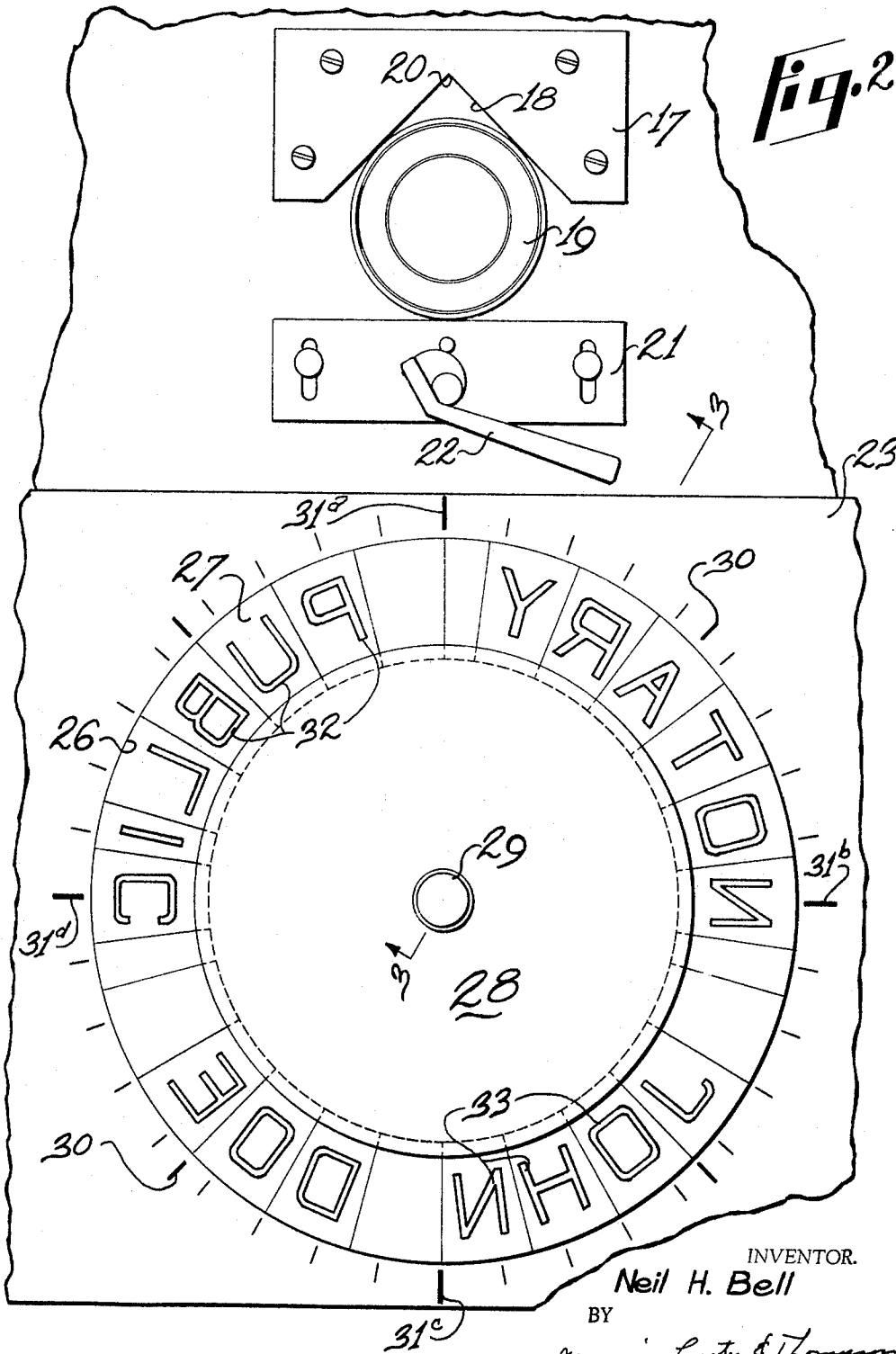

**Fig. 2**

INVENTOR.  
Neil H. Bell

BY  
*Jennings Carter & Thompson*  
Attorneys

1

2

3,263,333

**CIRCULAR TEMPLATE FOR ENGRAVING MACHINES AND THE LIKE**

Neil H. Bell, 201 18th Ave. NW., Birmingham, Ala.

Filed Apr. 6, 1964, Ser. No. 357,352

1 Claim. (Cl. 33—23)

This invention relates to master tracing templates for use with pantograph engraving machines, and more particularly to a circular template having removable indicia bearing type pieces for use as a master pattern in cutting intaglio indicia on seal dies, plates and the like.

The most common method presently employed for cutting intaglio indicia on seal dies and the like is to stamp or swage individual letters or the like into the die by means of a punch die and hammer, thus imprinting the seal die. This method requires a great deal of practice before an operator can become at all proficient, and it is virtually impossible consistently to produce dies of a uniform high quality. The depth to which the indicia are sunk cannot be regulated by such method, and spacing of the individual characters is at best skilled guesswork.

Efforts have been made to apply the engravers art to the "striking" of indicia into the seal die. Heretofore these methods have generally required a sort of turntable arrangement for holding the die blank in selected rotational positions. These operations are generally as follows: one character is engraved, the next character is chosen and the turntable is rotated in order to provide the required spacing of the characters, the turntable is then locked in position and the second character engraved, etc., until the entire die has been cut with the desired indicia. This is a tedious operation and, again, spacing of the individual characters is either by guesswork or by elaborate calculation.

In view of the foregoing a primary object of my invention is to provide a master pattern or template particularly adapted for use with a pantograph engraving machine in cutting or "striking" indicia into a seal die blank or the like.

Another object of my invention is to provide a template of the character designated in which the individual indicia characters may be quickly and accurately spaced without guesswork or calculations as to spacing and position of the format on the piece to be engraved.

Still another object of my invention is to provide a template of the character designated in which the indicia bearing type pieces have intaglio indicia on both sides thereof, one side being adapted for use in engraving the upper side of a curved arrangement of indicia, and the other side being adapted for use on the lower side of such arrangement.

A still further object of my invention is to provide a template of the character designated which may be used by relatively unskilled operators to produce substantially perfect dies.

Apparatus embodying features of my invention is illustrated in the accompanying drawings forming a part of this application, in which:

FIG. 1 is a plan view of a typical pantograph type engraving machine, showing my improved master pattern template and a seal blank in position thereon;

FIG. 2 is an enlarged fragmental plan view showing the template and the means for holding the die in place;

FIG. 3 is a detail sectional view partly broken away and taken along the line 3—3 of FIG. 2;

FIG. 4 is a detail view showing one side of a piece of type; and,

FIG. 5 is a detail view showing the other side of the piece of type shown in FIG. 4.

In FIG. 1 I show a typical pantograph type of engraving machine such as may be bought from the Green Instrument Company, Inc., 295 Vassar Street, Cambridge, Massachusetts. The engraving machine is indicated generally by the numeral 10. It embodies a pantograph assembly 11 which carries a tracing stylus 12 and an engraving tool 13 which is powered by a high speed electric motor 14. The pantograph assembly 11 is adjustably mounted over a work surface or table 16. The fixed pivot point of the pantograph is indicated generally at 15. On the table 16 I provide a die blank clamping means comprising a fixed plate 17 having a V cut-out 18 in one side thereof which is adapted to receive the seal blank 19, and a movable chuck plate 21. As shown more clearly in FIG. 2 the plate 21 is moved into locking contact with the die blank 19 by means of a spiral cam and lever assembly indicated generally at 22. Thus, the die blank is centered and held securely in position on the work table 16. As shown in FIG. 1 the base member 23 of the master pattern or template is secured to the work table 16 by means of screws 24.

As shown most clearly in FIGS. 2 and 3 the engraving template comprises the aforementioned plate 23 in which I provide a circular groove 26. Indicia bearing type pieces 27 are adapted to fit snugly and slidably within the groove 26. Thus, the narrower ends 27<sup>a</sup> are concave, while the wider ends 27<sup>b</sup> are convex, whereby the ends are complementarily shaped to fit the adjacent curved sides of the groove. A hold-down or clamp member 28 is secured to the plate 23 by means of a screw 29. The hold-down plate 28 is a circular member having a diameter slightly greater than the minor diameter of the groove. That is to say, the hold-down plate extends slightly over the innermost end of the type pieces 27, thereby holding them in selected positions in the groove. The screw 29 is manually tightened and loosened, whereby the plate 28 is easily put in place and removed.

Reference indicia 31<sup>a</sup>, 31<sup>b</sup>, 31<sup>c</sup>, and 31<sup>d</sup> are provided adjacent the outer perimeter of the groove 26, whereby the groove is visibly divided into at least four segments or quadrants. Additionally, the quadrants may be subdivided by other marks 30. Thus, when the type pieces are assembled in the groove to form words they can be quickly and accurately spaced relative to each other by visual reference to the indicia 30 and 31. Blank spacing pieces 34 on which there are no indicia may be provided to further facilitate spacing the words and to fill the entire groove.

The V-shaped cut-out 18 is in the side of the plate 17 nearest the base member 23. The point or apex 20 of the cut-out lies on the line defined by the reference indicia 31<sup>a</sup> and 31<sup>c</sup> which also passes through the fixed pivot point 15. Thus, the die blank 19 is automatically centered and positioned so that the stylus 12 and the tool 13 contact corresponding points on the template and die respectively.

Each of the type pieces 27 bears an intaglio character 32 on one face thereof so oriented that the top of the character is adjacent the wider end of the type piece 27, as illustrated in FIG. 4. Another character 33 is engraved on the other side of the type piece 27 and is so oriented that the top of the character is adjacent the narrower end of the type piece 27, as illustrated in FIG. 5. The type piece 27 is placed within the groove so that the character 32 is uppermost when the character is to be above the "equator," so to speak, of the seal, and conversely the character 33 is uppermost when the character is to be below the "equator" of the seal. That is to say, when it is desired to have an upright character on the lower half of the seal the type piece 27 is oriented with the character 32 uppermost and when it is desired to have an upright character on the upper half of the

seal the type piece must be oriented so that the character 33 is uppermost, as illustrated in FIG. 2. For convenience the respective sides may be distinguished as, for instance, by coloring one side of each piece.

With the foregoing in mind the use of my invention may now be clearly explained. With the base member 23 secured in place on the work table 16, a seal blank 19 is placed within the V cut-out 18 of the fixed member 17 of the seal blank holding means. The member 21 is moved into locking engagement with the seal blank 19 by rotating the spiral cam and lever assembly 22 clockwise as viewed in FIGS. 1 and 2. The screw 29 is loosened and the hold-down plate 28 is removed, and any type pieces that may be in the groove 26 from a previous use are removed, or if to be reused, left in place. Other type pieces 27 are selected from the font of type and placed in the groove 26 to form words, etc. The words thus formed are visually spaced arcuately within the groove by observing the reference indicia 30 and 31 located on the plate around the groove. Thus, any group of indicia formed by the type can be set so that when the disc is cut, the indicia will occupy the identical arcuate position on the disc as it occupies in the template. The hold-down plate 28 is replaced and the screw 29 tightened, thus to hold the type pieces in their selected positions. The pantograph engraving assembly is then operated in the usual manner, cutting the intaglio characters into the seal blank. In the embodiment illustrated there is a four-to-one relationship between the template and the seal die and thus the pantograph is so adjusted that the characters engraved on the die are reduced to one-fourth the size of the character on the engraving template. The depth to which the indicia are cut into the die is regulated by a vertical adjustment of the engraving tool 13.

In view of the foregoing it is clear that I have devised a new and improved engraving template for engraving arcuately positioned characters into a seal die or the like. I have provided an engraving template that is easy to use and which gives uniform results. It is simple, versatile, inexpensive and durable.

While I have shown my invention in but one form, it will be obvious to those skilled in the art that it is not so limited, but is susceptible of various changes and modifications without departing from the spirit thereof, and I desire, therefore, that only such limitations shall

be placed thereupon as are specifically set forth in the appended claim.

What I claim is:

For use in intaglio engraving of metal plates and the like,

- (a) a plurality of type pieces each embodying a flat piece of material generally frusto-triangular in shape, the end nearest the apex of the triangle being concave and the end nearest the base of the triangle being convex,
- (b) intaglio indicia cut into one face of each of said type pieces with the top of the indicia adjacent said concave end of the type piece,
- (c) other intaglio indicia cut into the other face of each of said type pieces with the top of said other indicia adjacent said convex end of the type piece, and
- (d) said plurality of type pieces being arranged in a circular configuration patterned into "upper" and "lower" quadrants, the type pieces in the "upper" quadrant having uppermost the faces thereof on which the tops of the indicia are at the convex end of said pieces, and those pieces in the "lower" quadrant having uppermost the faces thereof on which the tops of the indicia are at the concave end of the pieces.

#### References Cited by the Examiner

##### UNITED STATES PATENTS

D. 144,094	3/1946	Anderson	33—23	X
424,636	4/1890	Anable	101—28	
544,193	8/1895	Pickles et al.	101—112	X
835,680	11/1906	Hanssen	33—23	
2,344,849	3/1944	Butler-Jones	33—23	X
2,627,658	2/1953	Green	33—25	
2,660,933	12/1953	Caring	33—23	X
3,110,966	11/1963	Hillig	33—25	

##### FOREIGN PATENTS

135,675 12/1919 Great Britain.

LEONARD FORMAN, *Primary Examiner.*

ISAAC LISANN, *Examiner.*

H. N. HAROIAN, *Assistant Examiner.*