

(19) World Intellectual Property
Organization
International Bureau



(43) International Publication Date
11 November 2004 (11.11.2004)

PCT

(10) International Publication Number
WO 2004/097324 A1

- (51) International Patent Classification⁷: F28F 9/26
- (21) International Application Number: PCT/JP2004/005638
- (22) International Filing Date: 20 April 2004 (20.04.2004)
- (25) Filing Language: English
- (26) Publication Language: English
- (30) Priority Data:
2003-123163 28 April 2003 (28.04.2003) JP
60/477,775 12 June 2003 (12.06.2003) US
- (71) Applicant (for all designated States except US): SHOWA DENKO K.K. [JP/JP]; 13-9, Shiba Daimon 1-chome Minato-ku Tokyo, 1058518 (JP).
- (72) Inventor; and
- (75) Inventor/Applicant (for US only): IKAWA, Yohei [JP/JP]; c/o SHOWA DENKO K.K., OYAMA REGIONAL OFFICE 480, Inuzuka 1-chome Oyama-shi Tochigi, 3238678 (JP).
- (74) Agents: HIBI, Norihiko et al.; c/o Kishimoto & Co. 3rd Floor, Inaba Building 13-18, Nishishinsaibashi 1-chome, Chuo-ku, Osaka-shi, Osaka, 5420086 (JP).
- (81) Designated States (unless otherwise indicated, for every kind of national protection available): AE, AG, AL, AM, AT, AU, AZ, BA, BB, BG, BR, BW, BY, BZ, CA, CH, CN, CO, CR, CU, CZ, DE, DK, DM, DZ, EC, EE, EG, ES, FI, GB, GD, GE, GH, GM, HR, HU, ID, IL, IN, IS, KE, KG, KP, KR, KZ, LC, LK, LR, LS, LT, LU, LV, MA, MD, MG, MK, MN, MW, MX, MZ, NA, NI, NO, NZ, OM, PG, PH, PL, PT, RO, RU, SC, SD, SE, SG, SK, SL, SY, TJ, TM, TN, TR, TT, TZ, UA, UG, US, UZ, VC, VN, YU, ZA, ZM, ZW.
- (84) Designated States (unless otherwise indicated, for every kind of regional protection available): ARIPO (BW, GH, GM, KE, LS, MW, MZ, SD, SL, SZ, TZ, UG, ZM, ZW), Eurasian (AM, AZ, BY, KG, KZ, MD, RU, TJ, TM), European (AT, BE, BG, CH, CY, CZ, DE, DK, EE, ES, FI, FR, GB, GR, HU, IE, IT, LU, MC, NL, PL, PT, RO, SE, SI, SK, TR), OAPI (BF, BJ, CF, CG, CI, CM, GA, GN, GQ, GW, ML, MR, NE, SN, TD, TG).
- Published:
— with international search report

[Continued on next page]

(54) Title: SIDE PLATE FOR HEAT EXCHANGER, HEAT EXCHANGER AND PROCESS FOR FABRICATING THE HEAT EXCHANGER

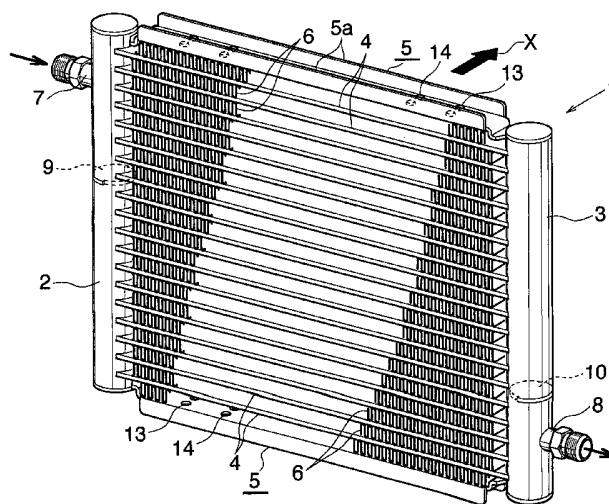

(57) Abstract: A side plate 5 is designed for use in a condenser 1 comprising a pair of headers 2, 3 arranged as spaced apart from each other, a plurality of flat refrigerant tubes 4 arranged in parallel as spaced apart from one another between the headers 2, 3 and each having opposite ends joined to the respective headers 2, 3, and corrugated fins 6 arranged between adjacent refrigerant tubes 4. The side plate 5 is disposed externally of and at a distance from the refrigerant tube 4 at each of opposite ends of the tube arrangement. A corrugated fin 6 is disposed between the side plate 5 and the end refrigerant tube 4 adjacent thereto. The side plate 5 is provided with a projection 13 at each of opposite end portions of a surface thereof opposite to the other surface in contact with the corrugated fin 6. The side plate 5 functions to prevent the fin 6 from slipping off from between the tube 4 and the side plate 5 in fabricating the condenser 1.

WO 2004/097324 A1



For two-letter codes and other abbreviations, refer to the "Guidance Notes on Codes and Abbreviations" appearing at the beginning of each regular issue of the PCT Gazette.

DESCRIPTION

SIDE PLATE FOR HEAT EXCHANGER, HEAT EXCHANGER AND PROCESS FOR
FABRICATING THE HEAT EXCHANGER

5

CROSS REFERENCE TO RELATED APPLICATIONS

This application is an application filed under 35 U.S.C.
§111(a) claiming the benefit pursuant to 35 U.S.C. §119(e)(1)
of the filing date of Provisional Application No. 60/477,775
10 filed June 12, 2003 pursuant to 35 U.S.C. §111(b).

TECHNICAL FIELD

The present invention relates to side plates for use in
heat exchanges, heat exchangers and a process for fabricating
15 the heat exchanger.

BACKGROUND ART

Heat exchangers are widely known which comprise a pair
of headers arranged as spaced apart from each other, a
20 plurality of flat heat exchange tubes arranged in parallel
as spaced apart from one another between the headers and each
having opposite ends joined to the respective headers, two
side plates disposed externally of and at a distance from
the respective flat heat exchange tubes at opposite ends of
25 the tube arrangement, and corrugated fins arranged between
adjacent heat exchange tubes and between each side plate and
the end exchange tube adjacent thereto.

Such heat exchangers are fabricated in the process to

be described below. The process includes arranging a plurality of flat heat exchange tubes in parallel as spaced from one another with two side plates arranged externally of and at a distance from the respective flat heat exchange tubes at opposite ends of the heat exchanger and arranging corrugated fins between adjacent heat exchange tubes and between each side plate and the end exchange tube adjacent thereto, placing opposite ends of the heat exchange tubes into corresponding insertion holes in a pair of headers, arranging pressure plates elongated longitudinally of the side plate on the respective side plates externally thereof, binding the pressure members, the side plates, the heat exchange tubes and the corrugated fins together with fastening members, and brazing the headers to the heat exchange tubes, and the corrugated fins to adjacent heat exchange tubes and the side plates.

In fabricating the heat exchanger by the above process, it is likely that the corrugated fin will slip out of the space between adjacent heat exchange tubes or between the end exchange tube and the side plate adjacent thereto before the completion of brazing after the components are bound with the fastening members.

A heat exchanger wherein the corrugated fins are prevented from slipping out of the space between adjacent heat exchange tubes is known. This heat exchanger has a projection provided on one of the heat exchange tube and the corrugated fin or between the heat exchange tube and the corrugated fin over the entire length of the tube. The projection locally causes a sacrificial deformation in bent portions of the corrugated

fin, and the corrugated fin in this state is brazed to the heat exchange tube (see, for example, JP-A No. 1995-55379, claims).

The corrugated fin between each end exchange tube and the side plate adjacent thereto also has the problem that each end of the fin will readily slip off, whereas no measure has been found out for solving this problem. Even if the technique of the above publication is applied to the side plate and the corrugated fin, the fin becomes locally deformed, consequently making the heat exchanger appear unsightly.

An object of the present invention, which has been accomplished in view of the above situation, is to provide a side plate for use in heat exchangers of the type described above which is adapted to prevent the corrugated fin from slipping off from between the side plate and the heat exchange tube adjacent thereto in fabricating the heat exchanger, the heat exchanger and a process for fabricating the heat exchanger.

DISCLOSURE OF THE INVENTION

To fulfill the above object, the present invention includes the following modes.

1) A side plate for use in heat exchangers comprising a pair of headers arranged as spaced apart from each other, a plurality of flat heat exchange tubes arranged in parallel as spaced apart from one another between the headers and each having opposite ends joined to the respective headers, the side plate disposed externally of and at a distance from the flat heat exchange tube at each of opposite ends of the tube

arrangement, and corrugated fins arranged between adjacent heat exchange tubes and between the side plate and the end exchange tube adjacent thereto,

the side plate for use in heat exchangers being provided
5 with a projection at each of opposite end portions of a surface thereof opposite to the other surface in contact with the corrugated fin.

2) A side plate for use in heat exchangers set forth in the above para. 1) wherein the projection is positioned at
10 a distance of up to 135 mm from the header when the side plate is incorporated into the heat exchanger.

3) A side plate for use in heat exchangers set forth in the above para. 1) wherein at least two projections are provided as spaced apart widthwise of the side plate at each end portion.

15 4) A side plate for use in heat exchangers set forth in the above para. 1) wherein the projection is 0.3 to 1 mm in height.

5) A side plate for use in heat exchangers set forth in the above para. 1) wherein the projection is circular and 1
20 to 4 mm in diameter.

6) A side plate for use in heat exchangers set forth in the above para. 1) wherein a second projection is formed at a distance from the projection at each end portion and positioned inwardly of the projection with respect to the longitudinal
25 direction of the side plate.

7) A side plate for use in heat exchangers set forth in the above para. 6) wherein the second projection is at a distance of up to 30 mm from the projection at each end portion.

8) A side plate for use in heat exchangers set forth in the above para. 6) wherein at least two second projections are provided as spaced apart widthwise of the side plate at each end portion.

5 9) A side plate for use in heat exchangers 6) wherein the second projection is 0.3 to 1 mm in height.

10) A side plate for use in heat exchangers 6) wherein the second projection is circular and 1 to 4 mm in diameter.

10 11) A heat exchanger comprising a pair of headers arranged as spaced apart from each other, a plurality of flat heat exchange tubes arranged in parallel as spaced apart from one another between the headers and each having opposite ends joined to the respective headers, a side plate disposed externally of and at a distance from the flat heat exchange tube at each
15 of opposite ends of the tube arrangement, and corrugated fins arranged between adjacent heat exchange tubes and between the side plate and the end exchange tube adjacent thereto, the side plate being one according to any one of above para. 1) to 10).

20 12) A refrigeration cycle comprising a compressor, a condenser and an evaporator, the condenser comprising a heat exchanger set forth in the above para. 11).

25 13) A refrigeration cycle comprising a compressor, a condenser and an evaporator, the evaporator comprising a heat exchanger set forth in the above para. 11).

14) A vehicle having installed therein a refrigeration cycle set forth in the above para. 12) or 13) as an air conditioner.

15) A process for fabricating a heat exchanger set forth

in the above para. 11) which includes:

arranging a plurality of flat heat exchange tubes in parallel as spaced from one another, disposing a side plate according to any one of claims 1 to 10 externally of and at a distance
5 from the flat heat exchange tube at each of opposite ends of the tube arrangement with the projections facing outward and arranging corrugated fins between adjacent heat exchange tubes and between the side plate and the end exchange tube adjacent thereto,

10 placing opposite ends of the heat exchange tubes into respective corresponding insertion holes formed in a pair of headers,

arranging a pressure plate having a length greater than the distance between the projections at the opposite end portions of the side plate, on each of the side plates externally thereof
15 in contact with the projections at the opposite end portions,

binding the pressure members, the side plates, the heat exchange tubes and the corrugated fins together with fastening members on widthwise opposite sides of the side plates, and

20 brazing the headers to the heat exchange tubes, and the corrugated fins to adjacent heat exchange tubes and to the side plates.

16) A process for fabricating a heat exchanger set forth in the above para. 15) wherein the side plate used is one set forth in any one of para. 6) to 10), and the components are
25 bound with the fastening members at locations closer to the respective headers than the projections at the respective end portions, and at locations inwardly of the respective second projections with respect to the longitudinal direction of the

side plate.

The side plate for heat exchangers which is described in the above para. 1) prevents opposite end portions of the corrugated fin from slipping off from between the side plate and the heat exchange tube at each end of the fin arrangement when the heat exchanger is fabricated. Stated more specifically, when the pressure members, side plates, heat exchange tubes and corrugated fins are bound together with fastening members in fabricating the heat exchanger by the process set forth in the para. 15), the side plates are deflected toward the heat exchange tubes by the pressure members which press the projections, whereby opposite end portions of the side plates are deflected toward the refrigerant tubes 4. As a result, opposite end portions of the corrugated fin 6 are held between the side plate 5 and the tube 4 with a great force and are prevented from slipping off.

When the pressure members, side plates, heat exchange tubes and corrugated fins are bound together with the fastening members, and when each of the side plates is the one described in the para. 2), the deflection of the side plates causes the fins to be held with an increased force, reliably preventing opposite end portions of the corrugated fin from slipping off from between the side plate and the refrigerant tube.

Opposite end portions of the corrugated fin as held between the side plate described in the para. 3) and the refrigerant tube can be clamped with an increased force and reliably prevented from slipping off.

When the pressure members, side plates, heat exchange

tubes and corrugated fins are bound together with the fastening members, and when each of the side plates is the one described in the para. 4), opposite end portions of the corrugated fin can be reliably prevented from slipping off from between the side plate and the heat exchange tube without permitting plastic deformation of the fin.

When the side plate described in the para. 5) is used, opposite end portions of the corrugated fin can be reliably prevented from slipping off from between the side plate and the refrigerant tube.

When the pressure members, side plates, heat exchange tubes and corrugated fins are bound together with the fastening members, and when each of the side plates is the one described in the para. 6), the side plate can be deflected over an increased length, with the result that opposite end portions of the corrugated fin can be reliably prevented from slipping off from between the side plate and the refrigerant tube.

When the side plate described in the para. 7) or 8) is used, the corrugated fin can be reliably prevented from slipping off between the first-mentioned projection and the second projection.

The side plate described in para. 9) exhibits the same advantage as the one described in para. 4).

The side plate described in para. 10) exhibits the same advantage as the one described in para. 5).

In fabricating the heat exchanger described in para. 11), the same advantages as described in para. 1) to 10) are available, with the result that opposite end portions of the corrugated

fin can be prevented from slipping off from between the side plate and the heat exchange tube.

The process described in the para. 15) for fabricating a heat exchanger has the same advantages as described in para. 5 1) to 10), whereby opposite end portions of the corrugated fin can be prevented from slipping off from between the side plate and the heat exchange tube.

The process described in the para. 16) for fabricating a heat exchanger reliably prevents opposite end portions of 10 the corrugated fin from slipping off from between the side plate and the heat exchange tube.

BRIEF DESCRIPTION OF THE DRAWINGS

FIG. 1 is an overall perspective view showing a condenser 15 having side plates of the present invention. FIG. 2 is a fragmentary front view partly broken away and showing the condenser. FIG. 3 is a perspective view showing the side plate of the invention with an intermediate portion thereof omitted.

FIG. 4 is a perspective view showing a process for fabricating 20 the condenser of FIG. 1, pressure members, the side plates, refrigerant tubes and corrugated fins being shown as bound together with fastening members. FIG. 5 is a fragmentary front view partly broken away showing the components in the same state as in FIG. 4.

25

BEST MODE OF CARRYING OUT THE INVENTION

Embodiments of the invention will be described below with reference to the drawings.

In the following description, the term "aluminum" includes aluminum alloys in addition to pure aluminum. Also in the following description, the upper and lower sides, and the left- and right-hand sides of FIG. 1 will be referred to as "upper," "lower," "left" and "right," respectively, and the downstream side with respect to the direction of flow of air through the condenser (the direction indicated by the arrow X in FIG. 1) will be referred to as "front," and the opposite side as "rear."

FIGS. 1 and 2 show a condenser which is adapted for use in motor vehicle air conditioners and wherein side plates of the invention are used. FIG. 3 shows the side plate. FIGS. 4 and 5 show a process for fabricating the condenser.

With reference to FIGS. 1 and 2, the condenser 1 (heat exchanger) for use in motor vehicle air conditioners comprises a pair of aluminum headers 2, 3 extending vertically and arranged in parallel as spaced from each other laterally, a plurality of parallel flat refrigerant tubes 4 (heat exchange tubes) of aluminum arranged as spaced from one another vertically and each having opposite ends joined to the respective headers 2, 3, aluminum side plates 5 disposed externally of and at a distance from the respective refrigerant tubes 4 at opposite ends of the condenser, i.e., above the refrigerant tube 4 at the upper end of the exchanger and below the refrigerant tube 4 at the lower end thereof, corrugated aluminum fins 6 arranged in respective air passing clearances between adjacent refrigerant tubes 4 and in an air passing clearance between each side plate and the end refrigerant tube adjacent thereto and brazed to the adjacent tubes and to the side plate and

the end tube, an aluminum inlet pipe 7 welded to a peripheral wall upper end portion of the first header 2, an aluminum outlet pipe 8 welded to a peripheral wall lower end portion of the second header 3, a first partition plate 9 provided inside the first header 2 at a position above the midportion thereof, and a second partition plate 10 provided inside the second header 3 below the midportion thereof. The refrigerant tube 4 to be used comprises an extruded tube, electroresistance-welded tube or the like. The refrigerant tube 4 to be used may be one made from a metal plate comprising two flat wall forming portions interconnected by a connecting portion, and two side wall forming portions each projecting from the flat wall forming portion integrally therewith at the side edge thereof opposite to the connecting portion, by bending the metal plate to the shape of a hairpin at the connecting portion and brazing the side wall forming portions to each other.

The number of refrigerant tubes 4 between the inlet pipe 7 and the first partition plate 9, the number of refrigerant tubes 4 between the first partition plate 9 and the second partition plate 10 and the number of refrigerant tubes 4 between the second partition plate 10 and the outlet pipe 8 decrease stepwise from above downward to provide groups of channels.

Before a refrigerant flowing into the condenser in a vapor phase through the inlet pipe 7 flows out of the outlet pipe 8 in a liquid phase, the refrigerant flows through the condenser zigzag via the units of channel groups.

Each refrigerant tube 4 has opposite ends placed into

respective insertion holes 11 formed in the headers 2, 3 and
brazed to the respective headers 2, 3. Each side plate 5 has
opposite ends also placed into respective insertion holes 12
formed in the headers 2, 3 and brazed to the respective headers
5 2, 3.

As shown in FIG. 3, the upper side plate 5 is provided
at each of opposite end portions thereof with a plurality of,
i.e., two, first projections 13 projecting from upper side
thereof and spaced apart toward the front or rear, i.e.,
10 widthwise of the side plate. When the side plate 5 is assembled
into the condenser 1, the distance A (see FIG. 2) from each
first projection 13 to the header 2 or 3 proximate thereto
is preferably up to 135 mm. The upper side plate 5 is also
provided on its upper side with a plurality of, i.e., two,
15 second projections 14 projecting upward, spaced apart widthwise
of the plate and positioned inwardly of each pair of first
projections 13 with respect to the lateral direction, i.e.,
longitudinally of the side plate 5. The distance B (see FIG.
2) between the first projections 13 and the second projections
20 14 at each end portion of the plate 5 is preferably up to 30
mm. Each of the two first projections 13 and the corresponding
second projection 14 are in the same position with respect
to the widthwise direction of the plate 15. The first
projections 13 and the second projections 14 each have a height
25 preferably of 0.3 to 1 mm. The first and second projections
13, 14 are each circular when seen from above and have a diameter
preferably of 1 to 4 mm.

The upper side plate 5 has an upright wall 5a at each

of its front and rear side edges integrally therewith. The upper side plate 5 has at each of its left and right ends a projecting portion 5c extending laterally outward from the main portion thereof integrally therewith with a stepped portion 5b formed therebetween, and positioned at a slightly lower level than the main portion. The projecting portion 5c has an insert 5d to be placed into the insertion hole 12 of the header 2 or 3.

The lower side plate 5 is symmetrical with the upper side plate 5 about a horizontal center line of the condenser 1. These side plates 5 are each formed as an integral piece from an aluminum plate by press work.

The condenser 1 described above is used, for example, in motor vehicle air conditioners for providing a refrigeration cycle along with a compressor and an evaporator.

The condenser 1 is fabricated by the process to be described below with reference to FIGS. 4 and 5.

First, a plurality of refrigerant tubes 4 are arranged in parallel as spaced from one another, two side plates 5 are arranged externally of and at a distance from the respective refrigerant tubes 4 at opposite ends of the arrangement with their projections 13, 14 facing outward, and corrugated fins 6 are arranged between adjacent refrigerant tubes 4 and between each side plate 5 and the end exchange tube 4 adjacent thereto.

Opposite ends of the refrigerant tubes 4 are then placed into respective corresponding insertion holes 11 in two headers 2, 3, and the inserts 5d of the side plates 5 at their opposite

ends are placed into the respective corresponding insertion holes 12 in the headers 2, 3. A first partition plate 9 is placed into the first header 2, and a second partition plate 10 into the second header 3.

5 On the outer surface of each side plate 5 between the upright walls 5a thereof is then placed a pressure member 20 elongated longitudinally of the side plate 5 so as to be in contact with all the projections 13, 14 thereof. The pressure member 20 is made, for example, from stainless steel, and has
10 a length approximately equal to the distance between opposite stepped portions 5b of the side plate 5 and greater than the spacing between the first projections 13 at the left and right end portions of the side plate 5.

Subsequently, the pressure members 20, side plates 5,
15 refrigerant tubes 4 and corrugated fins 6 are bound together with fastening members 21 each in the form of a belt. The assembly is thus bound at locations closer to the respective headers 2, 3 than the first projections 13 in the respective end portions of the side plate, and at locations inwardly of
20 the second projections 14 with respect to the longitudinal direction of the side plate 5. Consequently, the first projections 13 and the second projections 14 are pressed by the pressure members 20 owing to the force resulting from this binding (see arrows in FIGS. 4 and 5), whereby opposite end
25 portions of the side plates 5 are deflected toward the refrigerant tubes 4 (see FIG. 5). As a result, opposite end portions of the corrugated fin 6 are held between the side plate 5 and the tube 4 with a great force and are prevented

from slipping off. If the corrugated fin 6 is not smaller than 500 mm in length, opposite end portions thereof especially readily slip off from between the side plate 5 and the refrigerant tube 4, whereas if the distance A between the first projection 13 and the header 2 or 3 at each end is up to 135 mm, the corrugated fin 6 is clamped with an increased force owing to the deflection of the side plate 5, whereby the opposite end portions of the corrugated fin 6 are reliably prevented from slipping off from between the side plate 5 and the refrigerant tube 4. If the distance A is in excess of 135 mm, the opposite end portions of the corrugated fin 6 are likely to slip off from between the side plate 5 and the refrigerant tube 4. Further since the distance between the first projection 13 and the second projection 14 is up to 30 mm, the corrugated fin 6 is prevented from slipping off between the projections 13, 14. If this distance is in excess of 30 mm, the fin 6 is likely to slip off between these projections 13, 14. The first projections 13 and the second projections 14 are 0.3 to 1 mm in height, so that opposite end portions of the fin 6 can be reliably prevented from slipping off from between the side plate 5 and the refrigerant tube 4 without being deformed plastically. If the projections are less than 0.3 mm in height, the amount of deflection of the side plate 5 is small, permitting the side plate 5 and the refrigerant tube 4 to clamp the corrugated fin 6 with a small force and rendering opposite end portions of the fin 6 likely to slip off. When the projections are in excess of 1 mm in height, the side plate 5 will deflect to excess, plastically deforming the corrugated fin 6 to impair

the heat exchange performance of the condenser 1 fabricated.

The first projections 13 and the second projections 14 are circular when seen from above and are 1 to 4 mm in diameter.

Accordingly, opposite end portions of the corrugated fin 6
5 can be reliably prevented from slipping off from between the side plate 5 and the refrigerant tube 4 without causing plastic deformation of the fin 6.

Subsequently, the two headers 2, 3 are brazed to the refrigerant tubes 4, the two headers 2, 3 to the side plates
10 5, the corrugated fins 6 to adjacent refrigerant tubes 4 or to the side plate 5, and the headers 2, 3 to the respective partitions 9, 10 at the same time. Finally, the inlet pipe 7 is welded to the first header 2, and the outlet pipe 8 to the second header 3. In this way, a condenser 1 is fabricated.

15 According to the foregoing embodiment, the inserts 5d provided at opposite ends of the side plate 5 are placed into the corresponding insertion holes 12 formed in the respective headers 2, 3, whereas this construction is not limitative; the ends of the side plate 5 need not always be inserted into
20 the headers. Of course, in this case, the insertion holes are not formed.

Although the embodiment described above is a condenser for use in motor vehicle air conditioners, the heat exchanger comprising the side plate of the invention is usable also as
25 an evaporator for providing a refrigeration cycle along with a compressor and a condenser for use in motor vehicle air conditioners. The heat exchanger is further usable as a heater for motor vehicles.

INDUSTRIAL APPLICABILITY

The invention provides a side plate for use in heat exchangers which comprise a pair of headers arranged as spaced apart from each other, a plurality of flat heat exchange tubes arranged in parallel as spaced apart from one another between the headers and each having opposite ends joined to the respective headers, two side plates disposed externally of and at a distance from the respective flat heat exchange tubes at opposite ends of the tube arrangement, and corrugated fins arranged between adjacent heat exchange tubes and between each side plate and the end exchange tube adjacent thereto. The side plate is suitable for preventing the corrugated fin from slipping off in fabricating the heat exchanger.

CLAIMS

1. A side plate for use in heat exchangers comprising a pair of headers arranged as spaced apart from each other, a plurality of flat heat exchange tubes arranged in parallel
5 as spaced apart from one another between the headers and each having opposite ends joined to the respective headers, the side plate disposed externally of and at a distance from the flat heat exchange tube at each of opposite ends of the tube arrangement, and corrugated fins arranged between adjacent
10 heat exchange tubes and between the side plate and the end exchange tube adjacent thereto,

the side plate for use in heat exchangers being provided with a projection at each of opposite end portions of a surface thereof opposite to the other surface in contact with the
15 corrugated fin.

2. A side plate for use in heat exchangers according to claim 1 wherein the projection is positioned at a distance of up to 135 mm from the header when the side plate is incorporated into the heat exchanger.

20 3. A side plate for use in heat exchangers according to claim 1 wherein at least two projections are provided as spaced apart widthwise of the side plate at each end portion.

4. A side plate for use in heat exchangers according to claim 1 wherein the projection is 0.3 to 1 mm in height.

25 5. A side plate for use in heat exchangers according to claim 1 wherein the projection is circular and 1 to 4 mm in diameter.

6. A side plate for use in heat exchangers according to

claim 1 wherein a second projection is formed at a distance from the projection at each end portion and positioned inwardly of the projection with respect to the longitudinal direction of the side plate.

5 7. A side plate for use in heat exchangers according to claim 6 wherein the second projection is at a distance of up to 30 mm from the projection at each end portion.

 8. A side plate for use in heat exchangers according to claim 6 wherein at least two second projections are provided
10 as spaced apart widthwise of the side plate at each end portion.

 9. A side plate for use in heat exchangers according to claim 6 wherein the second projection is 0.3 to 1 mm in height.

 10. A side plate for use in heat exchangers according to claim 6 wherein the second projection is circular and 1
15 to 4 mm in diameter.

 11. A heat exchanger comprising a pair of headers arranged as spaced apart from each other, a plurality of flat heat exchange tubes arranged in parallel as spaced apart from one another between the headers and each having opposite ends joined
20 to the respective headers, a side plate disposed externally of and at a distance from the flat heat exchange tube at each of opposite ends of the tube arrangement, and corrugated fins arranged between adjacent heat exchange tubes and between the side plate and the end exchange tube adjacent thereto,
25 the side plate being one according to any one of claims 1 to 10.

 12. A refrigeration cycle comprising a compressor, a condenser and an evaporator, the condenser comprising a heat

exchanger according to claim 11.

13. A refrigeration cycle comprising a compressor, a condenser and an evaporator, the evaporator comprising a heat exchanger according to claim 11.

5 14. A vehicle having installed therein a refrigeration cycle according to claim 12 or 13 as an air conditioner.

15. A process for fabricating a heat exchanger according to claim 11 which includes:

arranging a plurality of flat heat exchange tubes in parallel
10 as spaced from one another, disposing a side plate according to any one of claims 1 to 10 externally of and at a distance from the flat heat exchange tube at each of opposite ends of the tube arrangement with the projections facing outward and arranging corrugated fins between adjacent heat exchange tubes
15 and between the side plate and the end exchange tube adjacent thereto,

placing opposite ends of the heat exchange tubes into respective corresponding insertion holes formed in a pair of headers,

arranging a pressure plate having a length greater than the
20 distance between the projections at the opposite end portions of the side plate, on each of the side plates externally thereof in contact with the projections at the opposite end portions,

binding the pressure members, the side plates, the heat exchange tubes and the corrugated fins together with fastening
25 members on widthwise opposite sides of the side plates, and

brazing the headers to the heat exchange tubes, and the corrugated fins to adjacent heat exchange tubes and to the side plates.

16. A process for fabricating a heat exchanger according to claim 15 wherein the side plate used is one according to any one of claims 6 to 10, and the components are bound with the fastening members at locations closer to the respective headers than the projections at the respective end portions, and at locations inwardly of the respective second projections with respect to the longitudinal direction of the side plate.

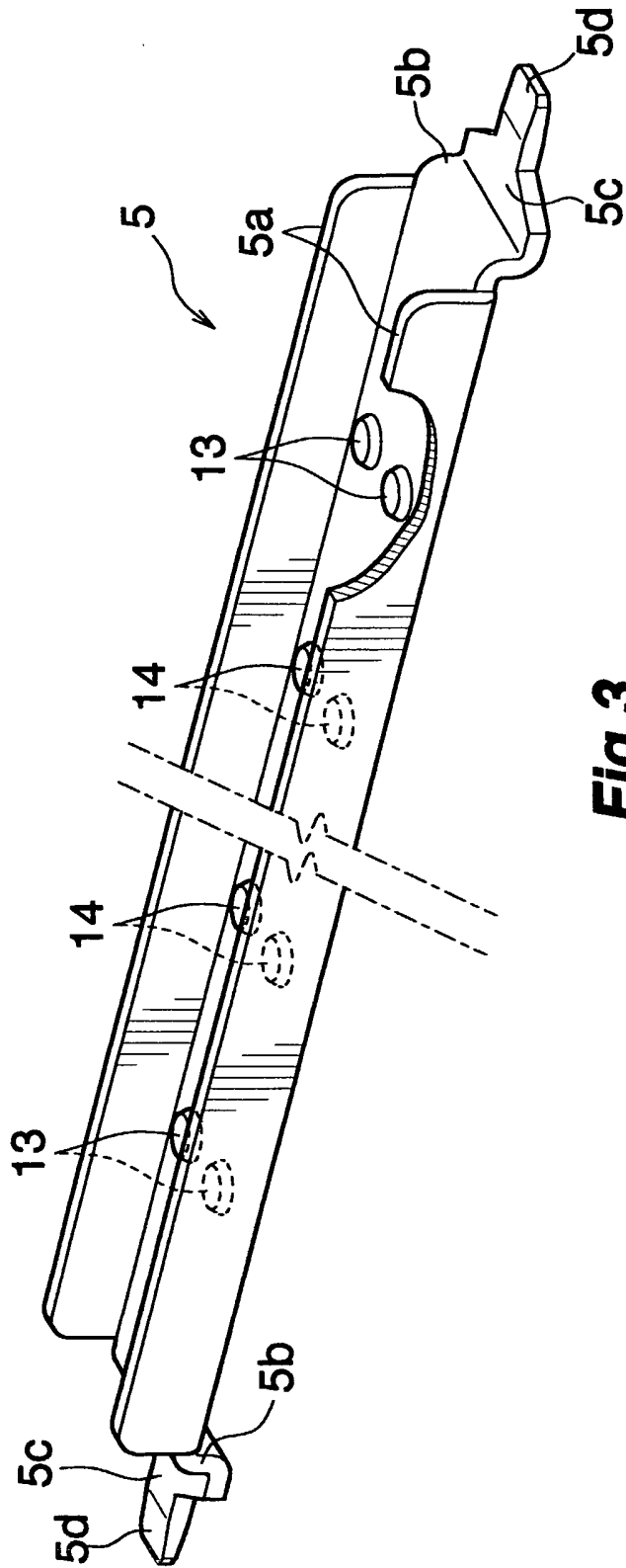

Fig.3

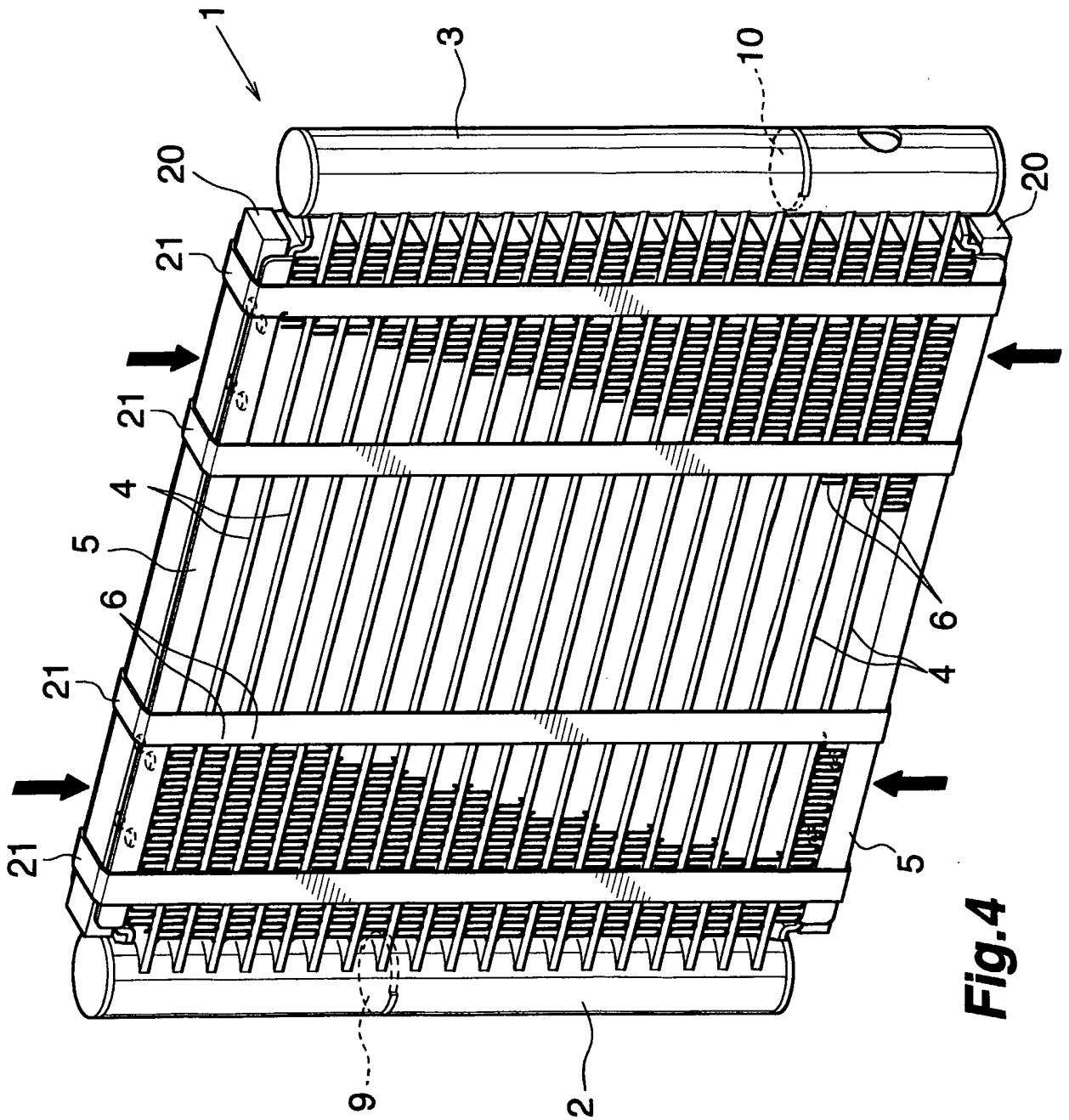

Fig.4

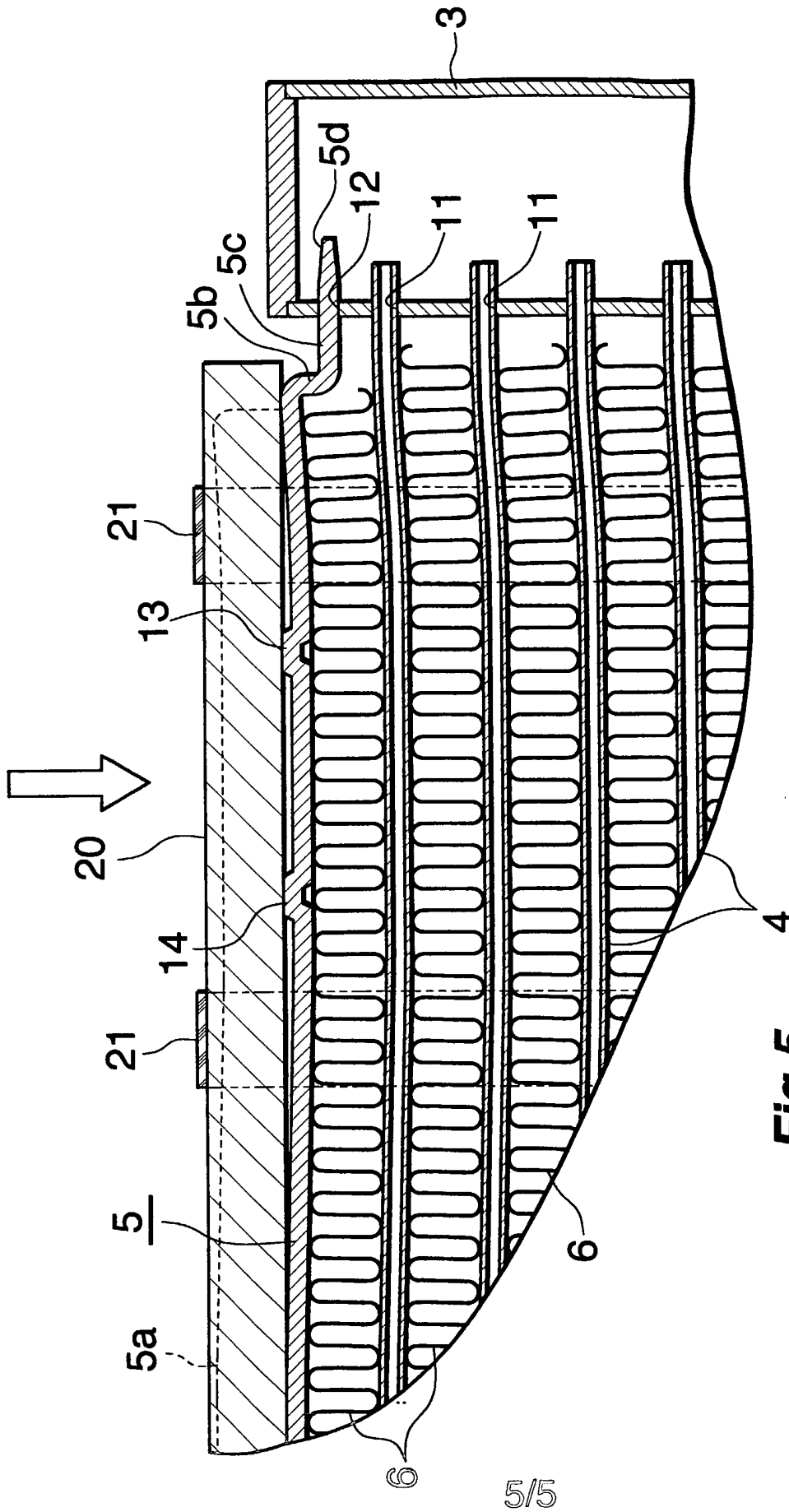

Fig.5

INTERNATIONALSEARCHREPORT

International application No.

PCT/JP 2004/005638

A. CLASSIFICATION OF SUBJECT MATTER

Int.Cl⁷ F28F 9/26

According to International Patent Classification (IPC) or to both national classification and IPC

B. FIELDS SEARCHED

Minimum documentation searched (classification system followed by classification symbols)

Int.Cl⁷ F28F 9/26

Documentation searched other than minimum documentation to the extent that such documents are included in the fields searched
 Japanese Utility Model Gazette 1922-1996, Japanese Publication of Unexamined Utility Model Applications 1971-2004, Japanese Registered Utility Model Gazette 1994-2004, Japanese Gazette Containing the Utility Model 1996-2004

Electronic data base consulted during the international search (name of data base and, where practicable, search terms used)

C. DOCUMENTS CONSIDERED TO BE RELEVANT

Category*	Citation of document, with indication, where appropriate, of the relevant passages	Relevant to claim No.
X Y	Microlfilm of the specification and drawings annexed to the written application of Japanese Utility Model Application No.10976/1987 (Laid-open No.121282/1988) (NIPPON RADIATOR CO., LTD.) 1988.08.05 (NO FAMILIES)	1-14, 16 15
Y	Microlfilm of the specification and drawings annexed to the written application of Japanese Utility Model Application No.517/1989 (Laid-open No.92492/1990) (DIESEL KIKI K.K.) 1990.07.23 (NO FAMILIES)	15

 Further documents are listed in the continuation of Box C. See patent family annex.

* Special categories of cited documents:

"A" document defining the general state of the art which is not considered to be of particular relevance

"E" earlier application or patent but published on or after the international filing date

"L" document which may throw doubts on priority claim(s) or which is cited to establish the publication date of another citation or other special reason (as specified)

"O" document referring to an oral disclosure, use, exhibition or other means

"P" document published prior to the international filing date but later than the priority date claimed

"T" later document published after the international filing date or priority date and not in conflict with the application but cited to understand the principle or theory underlying the invention

"X" document of particular relevance; the claimed invention cannot be considered novel or cannot be considered to involve an inventive step when the document is taken alone

"Y" document of particular relevance; the claimed invention cannot be considered to involve an inventive step when the document is combined with one or more other such documents, such combination being obvious to a person skilled in the art

"&" document member of the same patent family

Date of the actual completion of the international search

27.07.2004

Date of mailing of the international search report

10.8.2004

Name and mailing address of the ISA/JP

Japan Patent Office

3-4-3, Kasumigaseki, Chiyoda-ku, Tokyo 100-8915, Japan

Authorized officer

YOICHI NAGASAKI

Telephone No. +81-3-3581-1101 Ext. 3377

3M

8610