

W. G. NICHOLS.
 STONE CRUSHER HEAD.
 APPLICATION FILED SEPT. 6, 1906.

940,352.

Patented Nov. 16, 1909.
 2 SHEETS—SHEET 1.

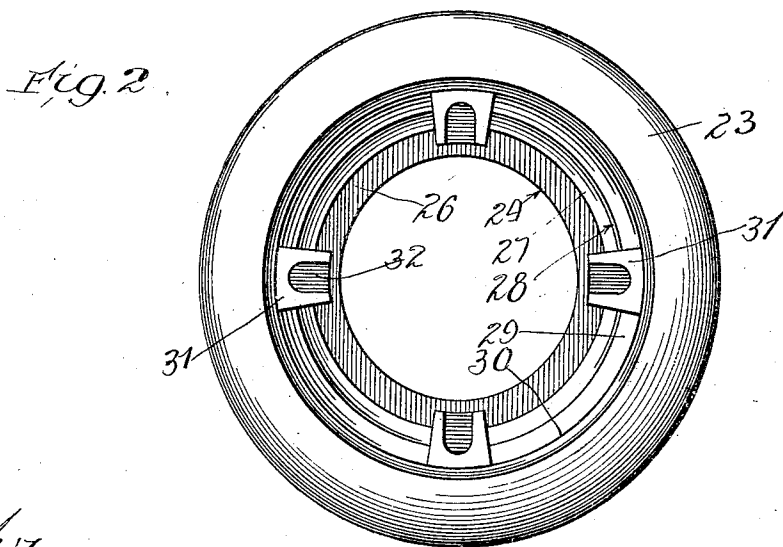
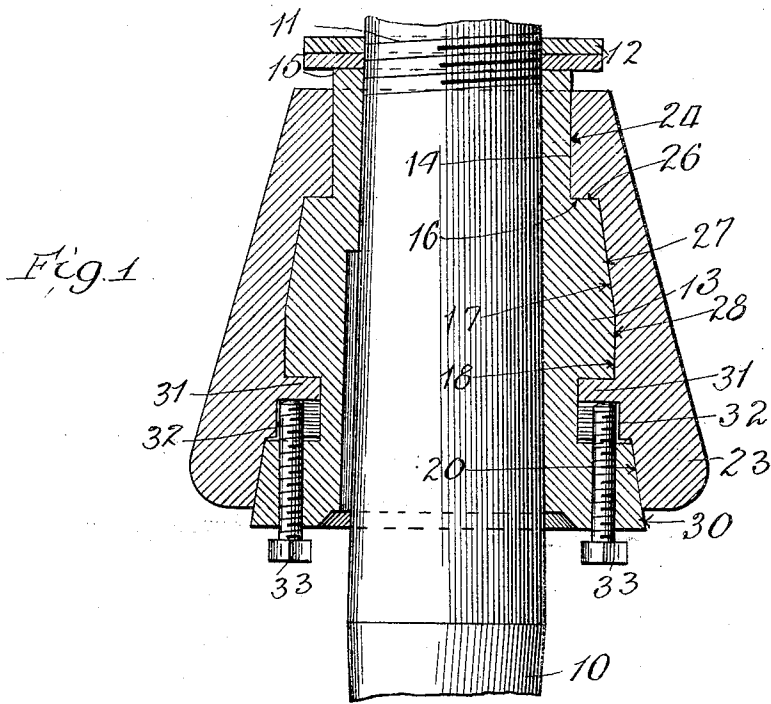

Witnesses:
 Ray White
 Harry R. L. White

Inventor
 Wesley G. Nichols
 By *Carroll Dain and May*
 Attorneys

W. G. NICHOLS.
 STONE CRUSHER HEAD.
 APPLICATION FILED SEPT. 6, 1906.

940,352.

Patented Nov. 16, 1909.
 2 SHEETS—SHEET 2.

Fig. 3.

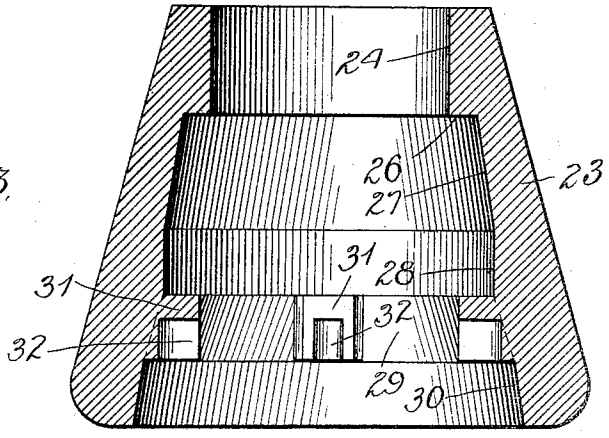

Fig. 4.

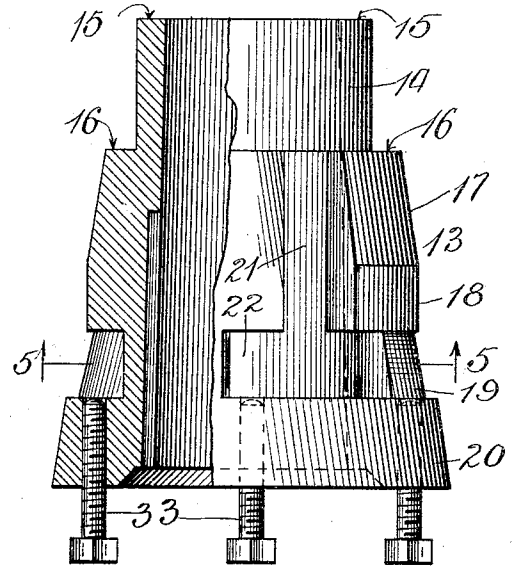
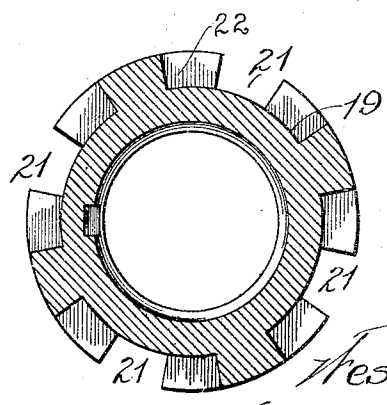

Fig. 5.



Witnesses:
 Ray White
 Harry R. Lull

Inventor:
 W. G. Nichols
 By Marie Bain and Mary [unclear] Attys

UNITED STATES PATENT OFFICE.

WESLEY G. NICHOLS, OF CHICAGO, ILLINOIS, ASSIGNOR TO AMERICAN BRAKE SHOE & FOUNDRY COMPANY, OF JERSEY CITY, NEW JERSEY, A CORPORATION OF NEW JERSEY.

STONE-CRUSHER HEAD.

940,352.

Specification of Letters Patent.

Patented Nov. 16, 1909.

Application filed September 6, 1906. Serial No. 333,559.

To all whom it may concern:

Be it known that I, WESLEY G. NICHOLS, a citizen of the United States, residing at Chicago, in the county of Cook and State of Illinois, have invented certain new and useful Improvements in Stone-Crusher Heads, of which the following is a specification.

My invention relates to improvements in heads for gyrating stone crushers.

The salient object of my invention is to provide a stone-crusher-head construction whereby I am enabled to employ a crushing surface of manganese steel, and am enabled to obviate or avoid the difficulties which have heretofore rendered the employment of this particular material impracticable.

More specifically an object of my invention is to provide a construction whereby I am enabled to employ a relatively thin renewable manganese steel wearing surface, or mantle, in association with a permanent core of ordinary steel.

A further object of my invention is to provide a construction wherein provision is made to compensate for the tendency of the manganese steel to stretch and distort under the strains and stresses incident to use, so that by distortion or stretching the mantle may not lose its efficiency in operation, or injure the associated core or shaft.

Another object of my invention is to provide a construction of maximum strength and rigidity at the plane where the maximum crushing action is effected.

Other and further objects of my invention will best become apparent from the following description, taken in conjunction with the drawings, wherein,

Figure 1 is a section of my improved crusher head complete. Fig. 2 is an end view of the mantle detached. Fig. 3 is a central section of the mantle detached. Fig. 4 is an elevation, with a fragment in section, of the core, and Fig. 5 is a section of the core on line 5-5 of Fig. 4.

Throughout the drawings like numerals of reference refer always to like parts.

Referring now to the drawings, 10 indicates the tapered crusher shaft, threaded as at 11, for the reception of jam-nuts 12-12, which overlie the upper end of the core 13, secured upon the shaft, to prevent vertical shifting of said core.

In the general configuration the core provides a reduced upper zone 14 of cylindrical

shape, upon the top surface 15 whereof, the jam-nut bears, said reduced, cylindrical portion, 14, terminating at a shoulder 16. Below the shoulder 16 is a tapered or conical zone 17, subjacent to which is a truly cylindrical zone 18, contiguous to the area on which the greatest crushing strain falls. Below the zone 18 are the beveled, or conical zones, 19 and 20.

In the enlarged portion of the core, at suitable distances apart, preferably on quadrants of a circle, are cut vertical grooves 21, extending from the shoulder 16 to the bottom of the zone 19, and having their bottom surfaces at a distance from the axis of the core not less than the radius of the cylindrical portion 14, of the core, said grooves communicating at their lower ends with lateral grooves 22, extending to like depth, and preferably extending in both directions from the vertical groove, forming with the groove 21, an inverted-T groove for a double-bayonet joint.

23 indicates in general a mantle, of any usual exterior configuration, preferably generally conical exteriorly and interiorly, and relatively thin, said mantle being composed of manganese steel, cast and ground to provide an interior configuration comprising interiorly the cylindrical wall 24, shoulder 26, conical portion 27, cylindrical portion 28 and conical portions 29 and 30, shaped to correspond and interfit with the respective portions 14, 16, 17, 18, 19 and 20 of the core. In vertical dimensions the zones 27, 28 and 29 of the mantle correspond with the measurement of the coacting part of the core, while the zones 24 and 30 of the mantle are shorter than the coacting part of the core. From the zone 29 of the mantle, there project inwardly lugs 31, of suitable shape to pass vertically through the slot 21 in the core, and rotarily into the lateral slots 22, the lugs 31 being of slightly less vertical extent than the slots 22, and the parts being so arranged that when shoulder 26 of the mantle bears upon shoulder 16 of the core, the upper surfaces of the lugs engage the top surfaces of the grooves 22, leaving a slight space between the bottoms of each lug and the like surface of the groove.

As illustrated in Fig. 1. the parts should be so accurately made as to produce close fits between the respective zones of contact, and the lugs should at their radially inner

surfaces effect bearing contact with the radially inner surfaces of the slot 22. In each lug is provided a recess 32, and through the lower zone of the core take vertical set-screws 33, in such position that they may be engaged with the recesses 32, when the lugs 31 are properly home in their grooves 32.

In many particulars the construction described is particularly adapted to the employment of manganese steel in the mantle construction. It is to be noted that the construction described permits of the use of relatively thin mantles, at no point far removed from a superficial area susceptible of treatment in the process of tempering. This is important, as it is a well known fact that to secure the best results in use articles of manganese steel should be tempered throughout the entire body, and further, that it is practicable to temper manganese steel only to the depth of a few inches from an exterior surface. It is also well known that manganese is of such tough and homogeneous character that it can not be turned or tooled after the fashion of common steel, but can be finished only by abrading, as by an emery wheel. It is to be noted that the interior configuration of the mantle is such as to permit ready grinding of all surfaces which are required to make close fit with the exterior surfaces of the core, while the core is of common steel, which may be machined in the ordinary manner to effect the snug fit with the mantle necessary to the best construction of the composite crusher head.

A further characteristic of manganese steel is that, while so impervious to cutting tools, it stretches materially under severe stress or strain, or when subjected to a peening action. In my improved construction the stretching of the mantle produces no deleterious effect. It is to be noted that long bearing surfaces, of truly cylindrical form, are provided at the zones 14, 18, and 24, 28, of the core and mantle respectively, so that the longitudinal, axial stretching of the mantle, due to its grinding activity does not result in a loss of fit between the core and mantle, or material loosening of the mantle on the core. Furthermore, the extension of the zone 14 of the core, beyond the confines of the corresponding zone 24 of the mantle, prevents the mantle in stretching from contacting with and stripping from their threads the jam-nuts 12. Likewise the extension of the conical zone 20 of the core below the coating area 30 of the mantle, permits of the downward extension of the mantle under stretching, without distorting of the general shape of the mantle and without permitting the mantle to envelop the lower edges of the core.

In assembling the parts the mantle is slipped on to the core with its lugs 31 taking into the grooves 21 of the core, and then

the mantle is rotated to bring the lugs 31 into those extensions of their corresponding grooves, which lie in rear of the vertical grooves 22 with reference to proposed direction of rotation of the head. When thus positioned, the set screws 33 are turned home to seat in the recesses 32 of the lugs, and the parts thereby positively secured together.

It is to be noted that at the point of maximum crushing strain, which is at about the level of the zone 29, the lugs of the mantle 31 make close contact at their radially inner ends with the core, and that positive connection is effected between the core and mantle in such zone, while in the zone immediately above a cylindrical bearing contact is effected between the core and mantle, which as described is not affected by any stretching which may occur in the mantle. Thus firm anchorage is afforded the mantle at the plane of greatest activity, and compensation is afforded for stretching above and below the anchorage.

Variations of details of construction will occur to those skilled in the art without departure from the spirit of my invention.

Having thus described my invention, what I claim and desire to secure by Letters Patent, of the United States, is:—

1. A composite crusher head, comprising a hollow, generally-conical manganese steel mantle, a coating generally-conical core within said mantle, longer than the mantle to permit a vertical extension of said mantle without loosening the support of the core, means effecting positive but detachable connections between the mantle and core only in a single zone below the middle of the mantle.

2. A composite crusher head, comprising a hollow, generally-conical manganese steel mantle, a common steel core shaped generally for coaction with said mantle, extending above the mantle at its upper end, in cylindrical form coinciding with a cylindrical upper portion in the inner surface of the mantle, and means effecting positive connection between the mantle and core in a single zone below the middle of the mantle, whereby a longitudinal extension of the mantle above the zone of positive connection does not free the mantle from the support of the core at its upper end.

3. The combination with a tapering shaft, of a core fitting thereon, jam nuts threaded on said shaft above the core, a mantle carried by the core, and effecting positive connection with the core only in a zone below the middle of the core, said mantle and core being provided with cylindrical coating surfaces adjacent their upper end, the cylindrical surface of the core extending beyond the end surface of the mantle to the end of the core with which the jam nuts coact,

whereby longitudinal stretching of the mantle to the end of the core may not free said mantle from support of the core or disturb the jam nuts.

5 4. In a composite crusher head, a hollow, generally conical manganese-steel mantle, a coating generally conical core, said core and mantle being provided at different vertical planes with cylindrical zones of varying diameters for maintaining contact under
10 different conditions of stretching of the mantle and means for securing said mantle and core together.

5. In a composite crusher head, a core of

generally conical exterior shape, a manganese steel mantle of generally conical shape
15 interfitting therewith, and means positively connecting said mantle with the core only in a zone below the center of the mantle, said
20 core and mantle being provided with coating cylindrical surfaces closely contiguous to said zone of positive connection.

In testimony whereof I hereunto set my hand in the presence of two witnesses.

WESLEY G. NICHOLS.

In the presence of—
CHARLES GUEST,
C. G. BAIR.