

(No Model.)

H. C. COMEGYS, A. B. HOLMES, & D. BOUCHER.

CAR COUPLING.

No. 299,623.

Patented June 3, 1884.

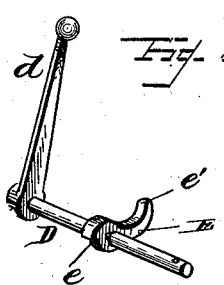
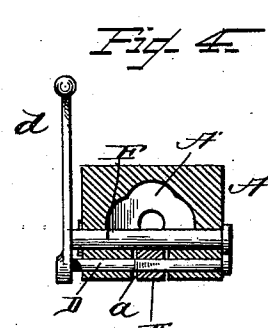
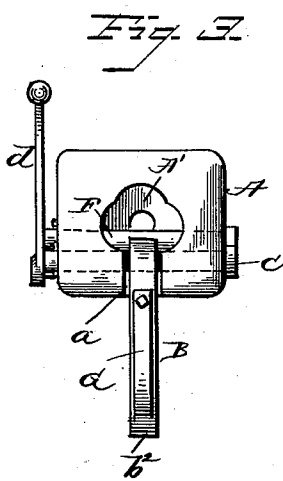
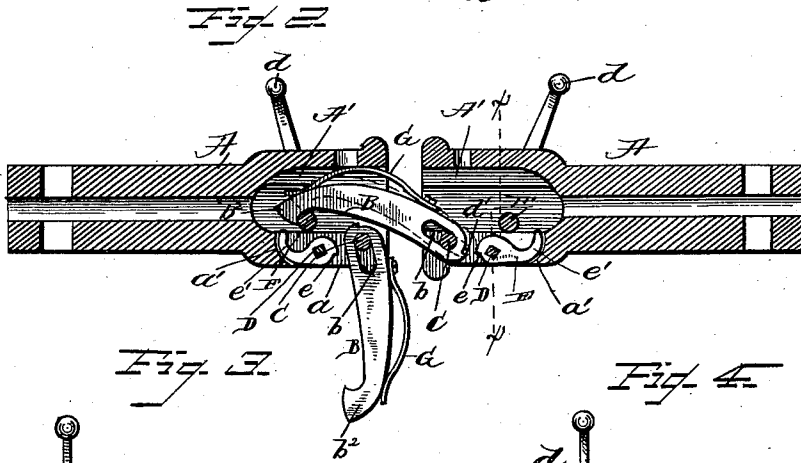
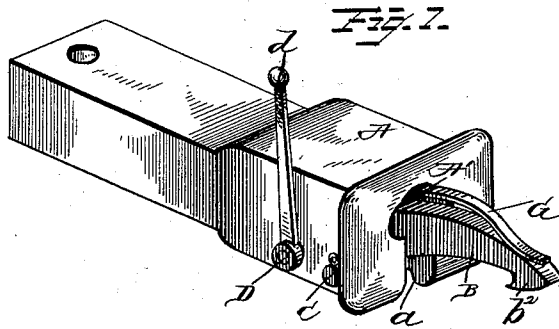

Henry C. Comegys,
 Andrew B. Holmes,
 David Boucher,

INVENTORS

WITNESSES
 F. L. Ourand
 J. B. Hayes.

J. R. Sittell,
 Attorney.

UNITED STATES PATENT OFFICE.

HENRY C. COMEGYS, ANDREW B. HOLMES, AND DAVID BOUCHER, OF SCRANTON, PENNSYLVANIA.

CAR-COUPLING.

SPECIFICATION forming part of Letters Patent No. 299,623, dated June 3, 1884.

Application filed April 11, 1884. (No model.)

To all whom it may concern:

Be it known that we, HENRY C. COMEGYS, ANDREW B. HOLMES, and DAVID BOUCHER, citizens of the United States, residing at Scranton, in the county of Lackawanna and State of Pennsylvania, have invented certain new and useful Improvements in Car-Couplings; and we do hereby declare the following to be a full, clear, and exact description of the invention, such as will enable others skilled in the art to which it appertains to make and use the same.

This invention relates to that class of automatic car-couplings in which a coupling-hook is adapted to engage a transverse pin in the adjoining draw-head.

The object of our invention is to provide a simple and improved coupling which can be operated or governed with superior convenience, facility, and safety, and which will possess advantages in point of strength and general efficiency.

In the drawings, Figure 1 is a perspective view of the draw-head, illustrating our improvement. Fig. 2 is a vertical longitudinal sectional view showing two adjoining draw-heads coupled together. Fig. 3 is a front or face view of the draw-head. Fig. 4 is a vertical transverse sectional view taken on the line *xx*, Fig. 2. Fig. 5 is a detail perspective view of the cam mechanism by which the hook is retained at a sufficient elevation to effect automatic coupling.

Corresponding parts in the figures are denoted by the same letters of reference.

Referring to the drawings, A designates the draw-head, at the front of which is provided the usual recess or chamber, A', a longitudinally-extending slot, *a*, being provided in the bottom of the latter.

B is the coupling-hook, which is preferably curved, as shown, and formed of steel, and it is provided at its rear end with a slot, *b*, which receives a transverse pin or bar, C, extending through the draw-head and through the front end of the slot *a*. Thus the bar C forms the pivot-pin of the hook as the rear end of the latter works in the slot *a*. A trans-

verse shaft, D, is arranged in rear of the pin C, and has its bearings in the draw-head, an operating arm or handle, *d*, being provided upon the end of the shaft at one side of the draw-head. A cam-piece, E, is secured centrally upon this shaft D, and works in the slot *a*. This cam is provided with a shoulder, *e*, at its front portion, and is provided with a projecting curved rear end, *e'*, the rear end *a'* of the slot *a* being preferably correspondingly curved, so that it will form a support for the cam when it is in its normal position. A corresponding shoulder, *d'*, is provided in the rear end of the hook B, and is adapted to be engaged with the shoulder upon the cam when the hook is set back upon its pivot-pin, as illustrated in dotted lines, Fig. 2, of the drawings. By this means the coupling-hook is set and retained at a sufficient elevation to effect an automatic coupling when the draw-heads come together.

F designates a transverse horizontal coupling-pin, which extends through the draw-head on a plane above the cam E, whereby when the coupling-hook enters the draw-head its curved nose *b'* engages this pin, and thereby effects a coupling. A flat bowed spring, G, is secured upon the top edge of the coupling-hook, and serves, by its engagement with the top of the recess A', to retain the nose of the hook down in engagement with the pin F against any accidental displacement. At the same time the coupling-hook has a free longitudinal movement upon its pivot-pin C, by reason of its pivot-slot *b*, to provide for the movements of the draw-heads while the cars are under draft.

From the foregoing description and annexed drawings it is evident that an automatic coupling can be readily secured by setting the coupling-hook of one of the draw-heads into engagement with its cam. To uncouple it is only necessary to operate the cam by means of the handle upon the end of its shaft to cause its rear end *e'* to elevate the nose of the hook from its engagement with the coupling-pin F, when the draw-heads may move apart, and the cam will return to its normal position by

its own gravity, in which position it may be again engaged by the shoulder upon the rear end of the coupling-hook.

To enable cars having our improved coupling to be coupled with cars having the ordinary pin-and-link coupling, the coupling-hook B may be thrown past the cam, so that it will depend from its pivot-pin C and be out of operation, and a vertical perforation, H, is provided in the top of the draw-head. When the coupling-hook is thus thrown down out of operation, an ordinary link may enter the recess A', and an ordinary pin may be inserted through the perforation H to effect a coupling. The slot *a* is preferably wider than the hook B, so that the said hook may be moved laterally upon its pivot-pin to permit the lower end of a vertical coupling-pin to be received by the slot *a* when it is desired to effect this ordinary pin-and-link coupling.

We claim as our invention—

1. As an improvement in car-couplings, the combination of the draw-head, a coupling-hook pivoted therein and provided with the shoulder at its rear end, and a cam-piece arranged at the bottom of the draw-head in rear of the hook and provided with a front shoulder to engage the shoulder upon the hook, substantially as set forth.

2. The combination of the draw-head, the coupling-hook having the pivot-slot in its rear end, and provided with the shoulder in rear of this slot, the transverse pivot-pin passing through the slot, the rock-shaft arranged in rear of the pivot-pin, and a cam-piece secured upon the rock-shaft and provided with a shoulder adapted to engage the shoulder of the coupling-hook, substantially as set forth.

3. The combination of the draw-head having the front chamber or recess and the slotted bottom, the coupling-hook having the slot at its rear end and the shoulder in rear of the slot, a transverse rock-shaft, a cam-piece secured upon this shaft and having the shoulder, and the transverse coupling-pin arranged on a horizontal plane above the cam-piece, substantially as set forth.

4. The herein-described improved car-coupling, comprising the draw-head having the chamber or recess and the longitudinally-extending slot in the bottom thereof, the transverse pivot-pin extending through this slot, the coupling-pin having the pivot-slot and the shoulder at its rear end and provided with the flat retaining-spring at its top, the rock-shaft arranged in rear of the pivot-pin, the cam-piece secured centrally upon this shaft and having the front shoulder and the projecting rear end, the rear end of the slot in the draw-head being adapted to support this rear end of the cam-piece and corresponding therewith, and a transverse coupling-pin arranged above the cam-piece, substantially as set forth.

5. As an improvement in car-couplings, the combination, with a draw-head having a transverse coupling-pin over which the coupling-hook of an adjoining draw-head is adapted to engage, of a cam-piece secured upon an operating-shaft below this coupling-pin and projecting in rear of the latter to act directly upon the nose of the hook and elevate it above the pin, substantially as set forth.

6. The combination, with a draw-head having a transverse coupling-pin and a coupling-hook pivoted in front of the same, of a cam-piece arranged upon an operating-shaft in rear of said hook and under the said coupling-pin, the front portion of the cam being adapted to engage the hook, and the rear end of the cam being adapted to act in relation to the coupling-pin, substantially as and for the purpose set forth.

7. The combination, with the draw-head having the recess or chamber and the longitudinally-extending slot provided in the bottom thereof, and having a curved rear end, of a transverse rock-shaft, and a cam-piece secured thereto and having a projecting rear end corresponding to and normally resting upon the rear end of the said slot, substantially as set forth.

In testimony whereof we affix our signatures in presence of two witnesses.

H. C. COMEGYS.
ANDREW B. HOLMES.
DAVID BOUCHER.

Witnesses:

THOMAS W. EVANS,
B. G. MORGAN.