



INTERNATIONAL APPLICATION PUBLISHED UNDER THE PATENT COOPERATION TREATY (PCT)

<p>(51) International Patent Classification ⁶ : A61B 17/02, 19/00</p>	<p>A1</p>	<p>(11) International Publication Number: WO 97/10753 (43) International Publication Date: 27 March 1997 (27.03.97)</p>
<p>(21) International Application Number: PCT/US96/15091 (22) International Filing Date: 19 September 1996 (19.09.96) (30) Priority Data: 08/531,363 20 September 1995 (20.09.95) US (60) Parent Application or Grant (63) Related by Continuation US 08/531,363 (CON) Filed on 20 September 1995 (20.09.95) (71) Applicant (for all designated States except US): MEDTRONIC, INC. [US/US]; 7000 Central Avenue Northeast, Minneapolis, MN 55432 (US). (72) Inventors; and (75) Inventors/Applicants (for US only): BORST, Cornelius [NL/NL]; Obrechtlaan 55, NL-Bilthoven (NL). MANSVELT BECK, Hendricus, J. [NL/NL]; Bildzigt 14, NL-Bilthoven (NL). GRUNDEMAN, Paul, F. [NL/NL]; Lauriergracht 71 III, NL-1016 RH Amsterdam (NL). JANSEN, Erik, W., L. [NL/NL]; Lindenlaan 28, NL-3707 ES Zeist (NL).</p>	<p>(74) Agents: JARO, Michael, J. et al.; Medtronic, Inc. MS301, 7000 Central Avenue Northeast, Minneapolis, MN 55432 (US). (81) Designated States: AL, AM, AT, AU, AZ, BB, BG, BR, CA, CH, CN, CZ, DE, DK, EE, ES, FI, GB, GE, HU, IL, IS, JP, KE, KG, KP, KR, KZ, LK, LR, LS, LT, LU, LV, MD, MG, MK, MN, MW, MX, NO, NZ, PL, PT, RO, RU, SD, SE, SG, SI, SK, TJ, TM, TR, TT, UA, UG, US, UZ, VN, ARIPO patent (KE, LS, MW, SD, SZ, UG), Eurasian patent (AM, AZ, BY, KG, KZ, MD, RU, TJ, TM), European patent (AT, BE, CH, DE, DK, ES, FI, FR, GB, GR, IE, IT, LU, MC, NL, PT, SE), OAPI patent (BF, BJ, CF, CG, CI, CM, GA, GN, ML, MR, NE, SN, TD, TG). Published <i>With international search report.</i></p>	

(54) Title: METHOD AND APPARATUS FOR TEMPORARILY IMMOBILIZING A LOCAL AREA OF TISSUE

(57) Abstract

A method and apparatus for temporarily immobilizing a local area of tissue. In particular, the present invention provides a method and apparatus for temporarily immobilizing a local area of heart tissue to thereby permit surgery on a coronary vessel in that area without significant deterioration of the pumping function of the beating heart. The local area of heart tissue is immobilized to a degree sufficient to permit minimally invasive or micro-surgery on that area of the heart. The present invention features a suction device to accomplish the immobilization. The suction device is coupled to a source of negative pressure. The suction device has a series of suction ports on one surface. Suction through the device causes suction to be maintained at the ports. The device further is shaped to conform to the surface of the heart. Thus, when the device is placed on the surface of the heart and suction is created, the suction through the ports engages the surface of the heart. The suction device is further fixed or immobilized to a stationary object, such as an operating table or a sternal or rib retractor. Thus, the local area of the heart near the suction device is temporarily fixed or immobilized relative to the stationary object while suction is maintained. In such a fashion, the coronary artery may be immobilized even though the heart itself is still beating so that a bypass graft may be performed. In addition the suction device may be used in either a conventional, open-chest environment or in a minimally-invasive environment, e.g. endoscopic.

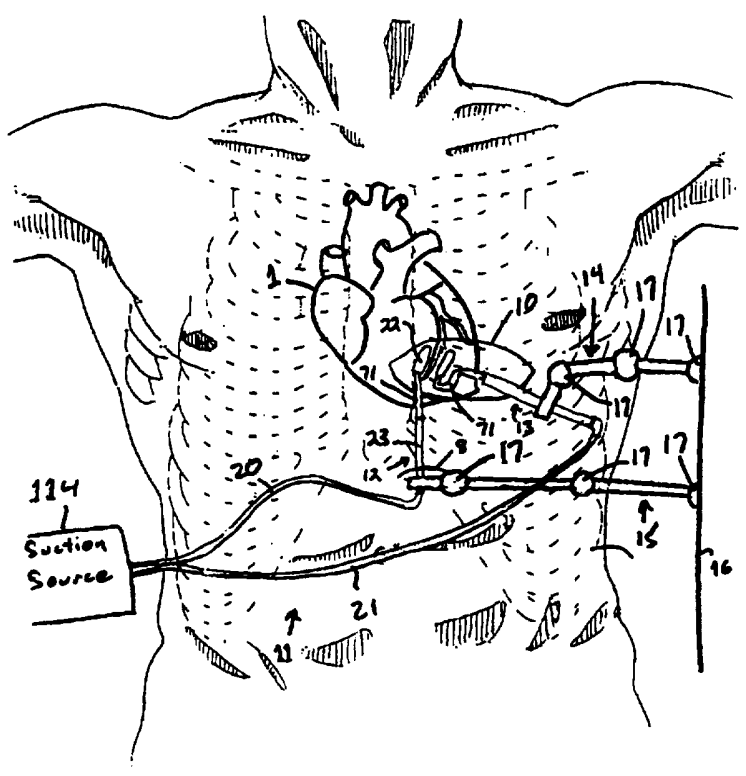

FOR THE PURPOSES OF INFORMATION ONLY

Codes used to identify States party to the PCT on the front pages of pamphlets publishing international applications under the PCT.

AM	Armenia	GB	United Kingdom	MW	Malawi
AT	Austria	GE	Georgia	MX	Mexico
AU	Australia	GN	Guinea	NE	Niger
BB	Barbados	GR	Greece	NL	Netherlands
BE	Belgium	HU	Hungary	NO	Norway
BF	Burkina Faso	IE	Ireland	NZ	New Zealand
BG	Bulgaria	IT	Italy	PL	Poland
BJ	Benin	JP	Japan	PT	Portugal
BR	Brazil	KE	Kenya	RO	Romania
BY	Belarus	KG	Kyrgyzstan	RU	Russian Federation
CA	Canada	KP	Democratic People's Republic of Korea	SD	Sudan
CF	Central African Republic	KR	Republic of Korea	SE	Sweden
CG	Congo	KZ	Kazakhstan	SG	Singapore
CH	Switzerland	LI	Liechtenstein	SI	Slovenia
CI	Côte d'Ivoire	LR	Liberia	SK	Slovakia
CM	Cameroon	LK	Sri Lanka	SN	Senegal
CN	China	LT	Lithuania	SZ	Swaziland
CS	Czechoslovakia	LU	Luxembourg	TD	Chad
CZ	Czech Republic	LV	Latvia	TG	Togo
DE	Germany	MC	Monaco	TJ	Tajikistan
DK	Denmark	MD	Republic of Moldova	TT	Trinidad and Tobago
EE	Estonia	MG	Madagascar	UA	Ukraine
ES	Spain	ML	Mali	UG	Uganda
FI	Finland	MN	Mongolia	US	United States of America
FR	France	MR	Mauritania	UZ	Uzbekistan
GA	Gabon			VN	Viet Nam

METHOD AND APPARATUS FOR TEMPORARILY IMMOBILIZING A LOCAL AREA OF TISSUE

FIELD OF THE INVENTION

5 The present invention generally relates to surgery on body tissues and organs. More specifically, the present invention relates to a method and apparatus for temporarily immobilizing a local area of tissue subject to motion, such as the heart wall, which permits a surgical procedure to be performed on that local area of tissue.

10 BACKGROUND OF THE INVENTION

 Coronary artery disease remains the leading cause of morbidity and mortality in Western societies. Coronary artery disease is manifested in a number of ways. For example, disease of the coronary arteries can lead to insufficient blood flow to various areas of the heart. This can lead to the discomfort of angina and the risk of ischemia. In severe cases, acute blockage of coronary blood flow
15 can result in irreversible damage to the myocardial tissue including myocardial infarction and the risk of death.

 A number of approaches have been developed for treating coronary artery disease. In less severe cases, it is often sufficient to merely treat the
20 symptoms, with pharmaceuticals, or treat the underlying causes of the disease, with lifestyle modification. In more severe cases, the coronary blockage can be treated endovascularly or percutaneously using techniques such as balloon angioplasty, atherectomy, laser ablation, stents, and the like.

 In cases where these approaches have failed or are likely to fail, it is
25 often necessary to perform a coronary artery bypass graft procedure. This procedure generally consists of the following steps: First, direct access to the heart is achieved. This is usually done by opening the chest by median sternotomy and spreading the left and right rib cage apart; and opening the pericardial sac to achieve direct access to the heart.

30 Next, a blood vessel or vessels for use in the graft procedure are mobilized from the patient. This usually entails mobilizing either a mammary artery or a saphenous vein, although other graft vessels may also be used.

Next, a heart-lung or cardiopulmonary bypass is performed. This usually entails arterial and venous cannulation, connecting the bloodstream to a heart-lung machine, cooling the body to about 32 degrees Celsius, cross-clamping of the aorta and cardioplegic perfusion of the coronary arteries to arrest and cool the heart to about 4 degrees Celsius. The arrest or stoppage of the heart is generally required because the constant pumping motion of the beating heart would make surgery upon the heart difficult in some locations and extremely difficult if not impossible in other locations

Once cardiac arrest is achieved, then a graft (or grafts) is attached to the relevant portions of a coronary artery (or arteries) followed by weaning from the cardiopulmonary bypass, restarting the heart and decannulation. Finally the chest is closed.

One area which may create difficulties for the patient and extra expense and time for the procedure involves the cardiopulmonary bypass. In a cardiopulmonary bypass all the patient's blood, which normally returns to the right atrium, is diverted to a system which supplies oxygen to the blood and removes carbon dioxide and returns the blood, at sufficient pressure, into the patient's aorta for further distribution into the body. Generally such a system requires several separate components, including an oxygenator, several pumps, a reservoir, a blood temperature control system, filters as well as flow, pressure and temperature sensors.

Problems may develop during cardiopulmonary bypass due to the reaction blood has to non-endothelially lined surfaces, i.e. surfaces unlike those of a blood vessel. In particular, exposure of blood to foreign surfaces results in the activation of virtually all the humoral and cellular components of the inflammatory response, as well as some of the slower reacting specific immune responses. Other complications from cardiopulmonary bypass include loss of red blood cells and platelets due to shear stress damage. In addition, cardiopulmonary bypass requires the use of an anticoagulant, such as heparin. This may, in turn, increase the risk of hemorrhage. Finally cardiopulmonary bypass sometimes necessitates giving

additional blood to the patient. The additional blood, if from a source other than the patient, may expose the patient to blood born diseases.

Due to the risks incurred during cardiopulmonary bypass, others have attempted to perform a coronary artery bypass graft procedure without cardiac arrest and cardiopulmonary bypass. For example, Trapp and Bisarya in
5 "Placement of Coronary Artery Bypass Graft Without Pump Oxygenator", Annals Thorac. Surg. Vol. 19, No. 1, (Jan. 1975) pgs. 1-9, immobilized the area of the bypass graft by encircling sutures deep enough to incorporate enough muscle to suspend an area of the heart and prevent damage to the coronary artery. More
10 recently Fanning et al. in "Reoperative Coronary Artery Bypass Grafting Without Cardiopulmonary Bypass", Annals Thorac. Surg. Vol. 55, (Feb. 1993) pgs. 486-489 also reported immobilizing the area of the bypass graft with stabilization sutures.

While these attempts have achieved some success, they generally
15 require enhanced skill of the surgeon to properly create the anastomosis because, even with sutures, the beating heart continues to move in the relevant area more than desired.

SUMMARY OF THE INVENTION

It is thus an object of the present invention to provide a method and
20 apparatus for temporarily immobilizing a local area of tissue, such as an area of a beating heart, without requiring the use of stabilizing sutures.

It is a further object of the present invention to provide a method and
apparatus to facilitate performing coronary artery bypass graft surgery on a beating
heart.

It is the further object of the present invention to provide a method
25 and apparatus to perform a coronary artery bypass graft without requiring the heart to be arrested or stopped and the patient coupled to a cardiopulmonary bypass machine.

These and other objectives are met by the present invention which
30 comprises a method and apparatus for temporarily immobilizing a local area of tissue. In particular, the present invention provides a method and apparatus for temporarily immobilizing a local area of heart tissue to thereby permit surgery on a

coronary vessel in that area without significant deterioration of the pumping function of the beating heart. The local area of heart tissue is immobilized to a degree sufficient to permit minimally invasive or micro-surgery on that area of the heart. The present invention features a suction device to accomplish the

5 immobilization. The suction device is coupled to a source of negative pressure. The suction device has a series of suction ports on one surface. Suction through the device causes suction to be maintained at the ports. The device further is shaped to conform to the surface of the heart. Thus, when the device is placed on the surface of the heart and suction is created, the suction through the ports engages the surface

10 of the heart. The suction device is further fixed or immobilized to a stationary object, such as an operating table or a sternal or rib retractor. Thus, the local area of the heart near the suction device is temporarily fixed or immobilized relative to the stationary object while suction is maintained. In such a fashion, the coronary artery may be immobilized even though the heart itself is still beating so that a

15 bypass graft may be connected to the coronary artery. In addition the suction device may be used in either a conventional, open-chest environment or in a minimally-invasive environment, e.g. endoscopic.

BRIEF DESCRIPTION OF THE DRAWINGS

The foregoing and other aspects of the present invention will best be appreciated with reference to the detailed description of the invention in conjunction with the accompanying drawings, wherein:

5 FIG. 1 is a plan view of the device being used to temporarily immobilize a local area of heart tissue in which access to the heart is achieved through a mini-thoractomy.

 FIGS. 2a and 2b depict a first type of suction device shown in use in FIG. 1.

10 FIGS. 3a and 3b depict a second type of suction device shown in use in FIG. 1.

 FIG. 4 is a longitudinal sectional view of the suction paddle used in the present invention.

15 FIG. 5 is a cross-sectional view of the suction paddle used in the present invention taken along the line 5-5 of FIG. 4.

 FIG. 6 is a longitudinal sectional view of the suction arm used in the present invention.

 FIG. 7 is a plan view of the suction arm used in the present invention.

20 FIG. 8 is a detailed view of a pair of suction devices being positioned on a heart and spread apart.

 FIGS. 9 and 10 show the effect of the spread-apart motion depicted in FIG. 8.

25 FIG. 11 is an example of the motion in the plane parallel to the surface of the heart of a point on heart tissue during one half respiratory cycle when the heart is unrestrained and also depicting the motion of the same point on heart tissue when the suction devices are used.

 FIG. 12 is an enlarged portion of FIG. 11 depicting the motion of the same point on heart tissue when the suction devices are used.

30 FIG. 13 is an alternate embodiment of the present invention.

FIG. 14 is a plan view of the device being used to temporarily immobilize a local area of heart tissue in which access to the heart is achieved through a median sternotomy.

5 FIG. 15 is a side view of an alternate embodiment of the present invention, shown placed against the surface of the heart.

FIG. 16 is a bottom view of the alternate embodiment of the present invention device shown in FIG. 15.

FIG. 17 is a side view of a further alternate embodiment of the present invention, shown placed against the surface of the heart.

10 FIG. 18 is a bottom view of still further alternate embodiment of the present invention.

FIG. 19 is a cross-sectional view of a body showing an alternative method of achieving access to the surface of the heart, and in particular of achieving such access using minimally invasive trocars.

15 FIG. 20A is a cross-sectional view of a body showing an alternate embodiment of the present invention, and in particular, an alternate embodiment of the securing device.

FIG. 20B is a top view of the embodiment shown in FIG.20A.

FIG. 21 is a perspective view of a securing device.

20 FIG. 22 depicts an overhead view of the securing device.

FIG. 23 is a side view of an alternate embodiment of suction device.

FIG. 24 is a further alternate embodiment of a suction device.

FIG. 25 is a perspective view of an alternate embodiment of an immobilizing device.

25 FIG. 26A is a view of the bottom of an alternate embodiment of a suction paddle used in the immobilizing device.

FIG. 26B is a perspective view of a further alternate embodiment of a suction paddle used in the immobilizing device.

30 FIG. 27 is a perspective view of a turning handle used to bend or orient the suction paddle portion of the immobilizing device.

FIG. 28 is a bottom view of an alternate embodiment of immobilizing device.

FIG. 29 is a plan view of a spreader used in an alternate embodiment of the present invention.

5 FIG. 30 depicts an alternate embodiment of spreader.

FIG. 31 depicts an alternate embodiment of immobilizing device and, in particular, an alternate embodiment of the securing device used to secure each suction paddle to the operating table rail.

FIG. 32 is a cross sectional view of the arm shown in FIG. 31.

10 FIG. 33 depicts a further alternate embodiment of the present invention, and in particular of a suction device substantially similar to that shown in FIG. 13 but for that the suction ports are located at the top of the suction paddle.

The drawings are not necessarily to scale.

DETAILED DESCRIPTION OF THE PREFERRED EMBODIMENT

15 FIG. 1 is a view of the immobilizing device 11 being used to temporarily immobilize an area of heart tissue. In the preferred embodiment, surgical access to the local area of heart tissue is achieved through a mini-thoracotomy, preferably performed within either the fourth or fifth intercostal space. An incision 10 of approximately 10 centimeters is made into chest cavity
20 between the ribs (seen here in phantom.) The rib cartilage may be temporarily removed and the ribs surrounding the incision slightly spread apart using a retractor (not shown) to provide adequate surgical access to the mammary artery and the heart. As seen, a pair of suction devices 12, 13 are introduced. The first suction device 12 is introduced through a small stab wound 8 in between the ribs
25 approximately 10 cm. below incision 10. This stab wound is made in any acceptable manner. Incidentally, once the surgery has been completed, the stab wound may be used for the thorax drain after the closure of the chest. As discussed below with reference to FIG. 19, the suction device has a covering 180, made from latex rubber, over the distal end when it penetrates the chest wall in
30 order to avoid blood and tissue from entering the suction ports and block suction apertures. Once suction device is introduced, covering 180 is removed and the

distal end is positioned onto heart. The second suction device 13 is introduced through incision 10 onto the surface of the heart. As seen, the distal end of each suction device is ultimately positioned in the local area of heart tissue to be immobilized, i.e. on either side of a coronary artery upon which a graft is to be made.

As seen, suction devices 12, 13 are secured using securing devices 14, 15 respectively to a stationary object, such as surgical table 16. Of course other objects besides the surgical table may be used as a stationary object, including the floor, ceiling or even the patient, such as a portion of the skeletal system of the patient, e.g. the sternum. In the preferred embodiment, each securing device 14, 15 is a variable friction arm, model no. 244 available from Manfrotto Nord, Inc. of Zona Industriale di Villapaiera, I-32032 Feltre BL, Italy. Each securing device 14, 15 has a series of elbow joints 17 which may be locked in position. Thus the securing device permits the suction device to be locked into any position desired within three-dimensional space. Although not shown, each securing device (or each suction device or both) may also be interconnected such that a truss type structure is created and the entire stiffness or rigidity of the immobilizing device 11 is improved.

Suction devices 12, 13 are coupled to a suction source 114 through lines 20, 21. Suction source 114 is preferably the standard suction available in the operating room and coupled to the devices with a two liter buffer flask (not shown) for each device. Suction is provided at a negative pressure of between 200-600 mm Hg with 400 mm Hg preferred. As seen, each suction device has essentially two portions, a paddle 22 and an arm 23. FIGS. 2 and 3 detail suction devices 12 and 13 respectively.

Turning now to FIGS. 2a and 2b, FIG. 2a is a side view of a suction device 12 showing its placement against the outline of a heart. As seen, the distal end of suction device comprises a paddle 22 and arm 23 coupled together by a continuous hinge or neck 71. Paddle 22 has a generally planar surface which conforms generally to the curvature of a heart 1, shown here in outline. In the preferred embodiment, suction arm 23 is coupled to suction paddle 22 such that

suction paddle 22 may be rotated or bent to achieve the desired orientation relative to arm 23. This is accomplished by neck 71. Neck 71 is fashioned to be relatively bendable, that is to be bent by hand into the desired orientation, as opposed to paddle 22 and arm 23, which are rigid. In the preferred embodiment suction paddle 22 and suction arm 23 are constructed of stainless steel 316, while neck 71 is constructed of stainless steel 321. Of course other means may be provided to permit paddle 22 to move or rotate relative to arm 23 other than making neck 71 to be malleable by hand, such as a locking hinge as well as a remotely actuatable joint, as is well known in the art. See for example, U.S. Patent No. 5,374,277 of Hassler, incorporated herein by reference. A remotely actuatable hinge is believed particularly advantageous for a suction device used endoscopically. In an alternate embodiment paddle may be fixed in a rigid orientation relative to arm. As seen, arm 23 has a suction lumen 30 therethrough which communicates with a suction conduit 31 in paddle 22 through neck lumen 72. Suction conduit 31 in paddle 22 further communicates through suction hole 32 (best seen in FIG. 2b) to suction port 33.

FIG. 2b is a view of the bottom of suction device 12. As seen, in the preferred embodiment four suction ports 33 in a row are featured, although the specific or exact number and position used may vary. Each suction port 33 has a suction aperture 32, each of which are preferably located at a position off-center from suction port 33. Suction apertures 32 are positioned off center from suction ports 33 so that if a large upwelling of tissue is caused by the suction (which may occur as a blister or bell-shaped curve) the tissue will not immediately close off the suction by obstructing suction aperture 32, as it would if the aperture were in the center of suction port 33. In addition, each suction aperture 32 has a much smaller diameter as compared to the diameter of suction port 33. This creates a high resistance pathway between suction port 33 and suction conduit 31 which permits the loss of a tissue-to-port seal in one suction port (and thus loss of fixation of the suction port to the tissue) to not also cause a precipitous pressure drop in the remainder of the suction ports. In the preferred embodiment suction aperture 32 has a diameter of 2 mm and suction port 33 has a diameter of 6 mm. As can be

seen through a comparison between FIGS. 2A and 2B the relatively straight sided suction ports define a generally planar surface through the ends of each port.

Turning now to FIGS. 3a and 3b, FIG. 3a is a side view of a suction device 13 shown in FIG. 1. As seen, the distal end of suction device 13 comprises paddle 22 and arm 23 coupled together by a continuous hinge or neck 71. Paddle 22 has a generally planar surface which conforms generally to the curvature of a heart 1. In the preferred embodiment, suction arm 23 is coupled to suction paddle 22 such that suction paddle 22 may be rotated or bent along any of the three axes to achieve the desired orientation relative to arm 23. This is accomplished by neck 71. Neck 71 is substantially similar to that discussed in FIG. 2a but for the fact that suction device 13 has suction paddle 22 at an angled orientation to suction arm 23. In the preferred embodiment suction paddle 22 of suction device 13 is perpendicular to suction arm 23, although other angular orientations may be used.

FIG. 3b is a view of the bottom of suction device 13. As seen, in the preferred embodiment suction paddle 22 of suction device 13 is substantially similar to that described in FIG. 2b. In the preferred embodiment suction aperture 32 has a diameter of 2 mm and suction port 33 has a diameter of 6 mm.

FIG. 4 is a longitudinal cross-sectional view of suction paddle 22 used in immobilizing device 11. As seen, paddle 22 has a series of suction ports 33 each of which is connected to suction conduit 31 through a suction aperture 32. Each suction port 33 has generally straight, cylindrical sides. Of course other configurations may be used, such as cone-shaped suction ports, dome-shaped suction ports, etc. As can be seen through this FIG. it is the bottoms or ends themselves of the suction ports define a generally planar surface through the ends of each port along the bottom surface of the paddle. Moreover, although shown here as conjoined or defining a continuous surface, suction ports may be further arranged such that they are each separate and distinct from one another, but which would still define a planar surface along through their ends along the bottom of the paddle.

FIG. 5 is a cross-sectional view of the suction paddle 22 taken along the line 5-5 of FIG. 4. As seen, suction port 33 is connected to suction conduit 31

through suction aperture 32. Suction paddle 22 has a canted or slanted surface 36 at the top. Through this type of surface, area 37 may be better accessed for performing surgical procedures.

FIG. 6 is a longitudinal cross-sectional view of suction arm 23. Distal end 71 of suction arm 23 has neck 71 (not shown in this FIG.) fixed thereto. As seen, arm 23 has a suction lumen 30 therethrough which communicates with suction conduit 31 in paddle 22 through neck lumen 72 of neck 71 (shown in phantom in this FIG.). As seen in FIG. 7, which is a plan view of suction arm 23, proximal end 75 has a series of knurled ridges 76 to facilitate coupling a suction line coming from suction source (not shown in this FIG) to suction arm 23.

FIG. 8 is a detailed view of a pair of suction devices 12, 13 being positioned on a heart and spread apart. As seen, paddles 22, 27 of each device generally are placed in the area 34 in which temporary immobilization of the heart tissue is desired. When used for a coronary bypass graft, area 34 typically will have a coronary artery 35 running therethrough. Area 34 is between paddles 22, 27. Once placed about area 34, suction is then created in the suction ports (not shown in this view.) Through the suction, the device then is fixed to or grabs hold of the heart tissue.

Once the suction is created and the paddles are secured to the heart tissue, each of the suction devices are then spread slightly apart as shown by the arrows 40, 41 to the positions shown as 42, 43. The effect of this spreading apart is to cause a tension to be created in the area 34 of the heart tissue between the paddles. The tension causes the area 34 to be further immobilized, and in particular in the Z-direction, i.e. in the direction normal to the plane defined by the surface of the heart. This is represented in FIGS. 9 and 10.

As seen in FIG. 9, the area of heart tissue between the paddles, even with the placement of the paddles, still has some vertical motion, shown here as arrow 50. When paddles 22, 27 are slightly spread apart to cause a tension in that area 34 of tissue between the paddles, as depicted in FIG. 10, then the amount of movement in the area 34 between the paddles 22, 27 due to the tension is further decreased, especially in the Z-direction, i.e. the direction perpendicular to the

surface of the heart 1. Once the paddles 22, 27 are thus positioned and secured and the area of the tissue is temporarily immobilized, the coronary artery in that area may be operated upon.

5 In the preferred embodiment, the anastomosis of the coronary artery may be accomplished through any acceptable end-to-side or side-to-side technique. Of course, other methods of performing the anastomosis may be used, such as those methods which may be performed endoscopically.

10 FIG. 11 is an example of the motion in the plane parallel to the surface of the heart of a point on heart tissue during one half respiratory cycle when the heart is unrestrained and also depicting the motion of the same point on heart tissue when the suction devices are used. Line 60 is a tracing of the motion of a point of tissue on the cardiac surface. As seen by line 60, a point on the cardiac surface moves approximately 15 mm in each direction. Generally, each loop of movement depicts the motion of the beating heart within one cardiac cycle. Thus, 15 loop 61 occurs due to one cardiac cycle. Loop 62 occurs due to the next cardiac cycle, but the entire heart has shifted in location somewhat due to the inflation or deflation of the lungs associated with respiration. Line 63 shows the motion of the same point of heart tissue when the suction device is placed near the area and the heart wall is immobilized by the present invention. As seen, the present invention 20 functions to minimize heart wall movement in that area to approximately 1 mm in each direction. This is best seen in FIG. 12 which is an enlarged portion of FIG. 11 and in particular line 63. As seen, through the use of the present invention, heart wall movement has been decreased to only slightly more than 1 mm. Decreased to an amount in the area of the suction devices such that the still-beating 25 heart may be operated upon in that area using an endoscope or any other method of minimally invasive surgery.

30 FIG. 13 is an alternate embodiment of the present invention. As seen, the embodiment of FIG. 13 comprises a suction sleeve 80 which is coupled to an annular suction head 81 via a ball bearing joint 84. Ball bearing joint 84 may be provided so as to permit remote actuation of the suction head 81 from a position outside the chest. The suction head 81 has a series of suction ports 82 located along

a first planar surface. In the embodiment shown the planar surface upon which the suction ports 82 are located is conical in shape, although other types of planar surface may be used, such as frusto-conical for example. The suction head 81 may be constructed such that each half of the device is coupled to a separate suction source. Through such a configuration, if one-half of the suction head 81 were to lose contact with the surface, the other one-half of the suction head 81 could maintain capture. The suction sleeve 80 is used as described above. That is the suction sleeve 80 itself is coupled to a suction source (not shown but the same as suction source 114) and is fixed or immobilized to a stationary point, such as the operating table or a retractor (also not shown.) Suction through the suction source and the suction sleeve 80 then causes the suction ports 82 to suck upon the heart tissue. Through this configuration, then, the heart tissue in the center of suction sleeve is immobilized. Interruption or opening 83 permits suction head 81 to be fixed to heart tissue while permitting a blood vessel to be grafted. In particular, if a mammary artery has been grafted end-to-side to a coronary artery, then the opening 83 permits the suction head 81 to be removed from around the grafted artery.

FIG. 14 is a view of the device being used to temporarily immobilize a local area of heart tissue using an alternative access procedure to the preferred mini-thoracotomy. In particular heart 1 is exposed with an incision 2 through the patient's sternum and the chest is spread apart by a retractor 3 to provide access to the heart 1. Access to the heart 1 is further effected by retraction of the pericardium 4 in the area of the heart 1 which is to be operated on. As shown pericardial retraction is accomplished through sutures 5.

As seen, the immobilizing device 11 comprises a pair of suction devices 12, 13 and a suction source 114. Suction devices 12, 13 are secured to patient by securing each to retractor 3 through a pair of clamps 19. Of course suction devices 12, 13 may also be secured to the operating table (not shown in this FIG. but using a securing device as described above.) Suction devices are coupled to suction source 114 through lines 20, 21. Suction source 114 is preferably the standard suction available in the operating room and coupled to the devices with a

two liter buffer flask (not shown) for each device. Suction is provided at a negative pressure of between 200-600 mm Hg with 400 mm Hg preferred. As seen, each suction device has essentially two portions, a paddle 22 and an arm 23.

Turning now to FIG. 15 which is a side view of an alternate
5 embodiment of suction device 12 showing its placement against the outline of a heart. As seen, the distal end of suction device comprises a paddle 22 and arm 23. Paddle 22 has a generally planar surface which conforms generally to the curvature of a heart 1, shown here in outline. The paddle 22 is coupled to arm 23 through a
10 pin 24. The pin 24 permits the paddle 22 to be swiveled to the preferred angle relative to arm 23. As seen, arm 23 has a suction lumen 30 therethrough which communicates with a suction conduit 31 in paddle 22. Suction conduit 31, in turn, communicates through suction aperture 32 (best seen in FIG. 4) to suction port 33.

FIG. 16 is a view of the bottom of suction device 12 shown in FIG.
15 15. As seen, four suction ports 33 in a row are featured, although the specific or exact number and position used may vary.

FIG. 17 is a further alternate embodiment of a suction device 12
20 showing its placement against the outline of a heart. As seen, suction device 12 is substantially similar to that shown and described in FIG. 2, but for the addition of suture coil 73. Suture coil 73 is a tightly wound spring fixed to the top surface of suction paddle 22. Further temporary stabilization of the coronary anastomosis site may be achieved, if desired, by catching epicardial flaps with light traction sutures. Suture coil 73 permits these and any other sutures to be temporarily fixed in place by wedging the suture between within suture coil 73, as is known in the art.

FIG. 18 is a bottom view of a further alternate embodiment of
25 suction device 12. As seen, suction device 12 is substantially similar to that shown and described in FIG. 2, but for the addition of electrode 174 along a side of suction paddle 22. Electrode 174 is coupled by lead 175 to pulse generator 176. Electrode 174, lead 175 and pulse generator 176 may be provided according to well know methods and materials so as to permit the heart to be paced, cardioverted
30 or defibrillated while suction device 12 is fixed to the surface of the heart.

FIG. 19 is a cross-sectional view of a body showing an alternate method of achieving access to a surface of the heart and using the present invention to immobilize an area of tissue. As seen suction device 12 is introduced through a first stab wound. As discussed above, suction arm 23 of device 12 is secured by securing device 14 to a stationary object, such as operating table 16. A second suction device may also be introduced through a second stab wound to securely immobilize a local area of tissue. Each suction device has a covering 180, made from latex rubber, over the distal end when it penetrates the chest wall in order to avoid blood and tissue from entering the suction ports and block suction apertures. Two or more additional surgical trocars 78 may be introduced to permit endoscopy and surgical access to heart 1. In addition the left lung 79 may also be partially collapsed so as to provide an unencumbered area in which to manipulate the surgical instruments.

FIG. 20A is a cross-sectional view of a body showing an alternate embodiment of the present invention, and in particular, an alternate embodiment of the securing device. In this embodiment, securing device comprises a pair of anchors 201, 202 which are attached to surgical table 203. As seen, surgical table is attached by pedestal 204 to the floor 205. Each anchor is attached on either side of the table using a pair of fasteners 206, 207. In the preferred embodiment, fasteners are a pair of screws which couple with longitudinal slots within each anchor to permit the anchors to be adjusted both in an inward and outward direction as well as up and down, as shown by the arrows. As seen, anchors are designed to follow the contour of patient 210 to thereby provide a smooth surface over which a surgeon may operate. Each anchor is attached to retractor 3 by fasteners 211, 212. On the retractor 3 a mounting rail 999 is attached, best seen in FIG. 20B discussed below. Attached in turn to mounting rail is a pair of slip-grip type holders 12A, 13A or any other holder which permits an object to be quickly but securely mounted or removed, and mounted in turn to holders are a pair of suction devices 12B, 13B as has been already previously discussed above. In the preferred embodiment, each anchor is a strip of biocompatible metal, such as stainless steel, approximately 5-8 centimeters in width and 0.6 - 0.8 centimeters in thickness. As

seen positioned at the bottom of anchors is a truss. In particular each anchor has fixed to it a descending member 216, 217, each of which are linked together by a pair of cross-braces 218, 219. Cross-braces may or may not be coupled together at their center points. As can be appreciated, through this truss construction the stability of anchors and thus the suction devices mounted thereto is increased.

FIG. 20B is a top view of the embodiment shown in FIG.20A. As seen, mounted to anchors 201, 202 is a mounting rail 999. In the preferred embodiment mounting rail is ellipsoidal in shape. As seen mounting rail is used to mount slip-grip type holders 12A, 13A and their corresponding suction devices. To be precise, mounting rail permits the suction devices to be securely mounted but yet be easily moved in the area of the surgical procedure. The ellipsoidal shape, moreover, corresponds more suitably to the surgical area. Of course, other shapes may also be used, such as circular, or non-symmetrical, for example. Of course other configurations of a mounting rail, retractor and anchor may be used, such as a retractor integral with the anchors or a mounting rail integral with the retractor or both, to mention only two of the many possibilities.

In use, access to the heart is achieved and retraction of the chest wall is performed prior to the positioning of the anchors. Once the heart access is achieved, the retractor is coupled to the anchors and the anchors are then fixed to the table. At this point, the retractor is thus immobilized with respect to the table and provides a stationary object to which the immobilizing device featuring the a pair of suction devices 12B, 13B may be coupled.

FIGS. 21 and 22 depict a further alternate embodiment of the securing device. FIG. 21 is a perspective view of a securing device. As seen, in this embodiment, the securing device comprises a pair of formed rails 220, 221. As seen, each rail is coupled to the surgical table 203 through a series of screws 222, 223. Although not shown in the FIGS. each rail further features a truss-like structure such as that shown in FIG. 20 A which is positioned below the table which provides additional rigidity and stability. As seen, each rail is further formed to slope inwardly toward the patient 210 (shown in outline in this FIG.) This provides for access above the patient by the surgeon. Straddling between each rail is a

mounting 224. The mounting is adjustable along the rail. The mountings are further designed to have a suction device mounted thereto. In such a manner, the mounting 224 and rails 220, 221 provide a stationary object to which the suction device may be mounted.

5 FIG. 22 depicts an overhead view of the rails 220, 221 used to position a suction device to the heart. As seen, in this embodiment, two suction devices 225, 226 are fastened to the mounting using a pair of slip-grip type holders 12A, 13A as already discussed above.

10 Turning now to FIG. 23 which is a side view of an alternate embodiment of suction device 12. As seen this alternate embodiment of suction device 12 features a suction port 33 as already described above. Each suction port is connected to a suction conduit 31 through a suction aperture 32 as also already described above. In this embodiment, however, the suction device further provides for the distribution of irrigation fluid onto the area of the heart where an
15 anastomosis will be performed. As seen, the irrigation fluid source 133 is coupled by an irrigation line 134 to the irrigation fluid conduit 135. The irrigation fluid conduit, in turn, is coupled to an irrigation hose 136. As shown, irrigation hose is designed to have some flexibility to permit it to be rotated and moved along several angles and is preferably a braided stainless steel hose. Irrigation hose dispenses
20 irrigation fluid at its end. Irrigation fluid preferably is a warm saline mist which prevents the exposed tissues from drying out. Moreover, the fluid is dispensed under pressure such that the mist has a force to it which permits the mist to be used to blow with sufficient force to assist in holding open a coronary artery such that the anastomosis may be performed more easily. Suction device further features a
25 return irrigation fluid circuit. As seen, return irrigation fluid circuit comprises a return irrigation port 140 which is coupled to a return irrigation conduit 141. Return irrigation conduit is coupled to a suction source to provide suction to return irrigation pipe 142 such that the irrigation fluid which is dispensed may be readily removed from the surgical area. Although shown as an integral part of the suction
30 device, both the irrigation system as well as the suction system may or may not be a part of the suction device.

FIG. 24 is a further alternate embodiment of a suction device. As seen, suction device features the suction port, suction conduit and suction aperture as already described above. In this embodiment, however, the suction device further features an optical fiber 150 which is coupled at one end to the area of the suction device where the anastomosis will be performed and is further coupled to a light source 151. In this manner, the suction device may be used to provide additional light 152 to the area where the anastomosis will be performed.

FIG. 25 is a perspective view of an alternate embodiment of an immobilizing device 11. As seen, in this embodiment, each suction device is coupled to a mounting beam 998 through a pair of holders 12A, 13 A as already described above with reference to FIG. 20A. Mounting beam 998 features two sections, each of which may be individually rotated about or spread apart or both. In particular mounting beam has a central screw members 997, 996. Each central screw member has an actuating knob 994, 995 at an end thereof. Rotation of each knob thereby causes the suction device mounted to that portion of the mounting beam to move either away or towards the center of the mounting beam, as indicated by line 993. Mounting beam 998 is mounted to a stationary object, such as a retractor, mounting rail or fixation arm, through a central arm 992. Each suction device may further be rotated relative to the mounting beam through simply moving each of the relevant devices, as indicated by the lines 991, 990. The use of mounting beam to retain suction devices is of use when only one fixation arm is to be used. In such a manner mounting beam permits both device to be fixed to a stationary object as well as permitting suction devices to be moved apart to thereby provide additional immobilization to a local area of tissue, as discussed above with regards to FIGS. 8-10.

FIG. 26A is a view of the bottom of an alternate embodiment of suction paddle 22 used in the immobilizing device. As seen, paddle has a series of suction ports, each of which is connected to suction conduit through a suction aperture. In this embodiment, the paddle features five suction ports. The additional side suction port is presented on the side of the suction paddle which will not be near the coronary artery or, in general, the surgical target. The additional

port increases the suction surface area. Each suction port 33 has a 6 mm diameter while each suction aperture 32 has a 2 mm diameter.

FIG. 26B is a perspective view of the bottom of an alternate embodiment of suction paddle 22 used in the immobilizing device. As seen in this
5 embodiment the paddle 22 is oriented at a ninety degree angle relative to the neck portion 71 and arm 23. Of course paddle may also be oriented at another suitable angle other than ninety degrees relative to neck portion. In this embodiment, the paddle features four suction ports, although more or less ports may also be provided. Each suction port 33 has a 6 mm diameter while each suction aperture 32
10 has a 2 mm diameter.

FIG. 27 is a perspective view of a turning handle 161 used to bend or orient the suction paddle 22 portion of the immobilizing device. As discussed above neck 71 is fashioned to be relatively bendable, as opposed to paddle 22 and arm 23. As seen, handle 161 features opening 980 having the same shape and
15 dimension of paddle such that paddle may thus be inserted therein. Handle also features neck portion 982 and grip portion 981, Neck and grip portion are dimensioned to provide leverage against opening 980 and thus paddle, neck and arm. To use, paddle is inserted into opening. Once inserted manipulation of grip portion relative to arm causes bending in the area of neck. Such a handle may be
20 advantageous as compared to bending of the device by hand in that it avoids the surgeon from straining hand muscles which will be needed to perform delicate manipulations.

FIG. 28 is a bottom view of an alternate embodiment of immobilizing device 11. As seen, immobilizing device features a pair of suction
25 paddles 171, 172, each of which is coupled to an arm by a continuous hinge or neck as discussed above. The arm in turn, is coupled to a stationary object, also discussed above. In this embodiment, the arms are further fastened together using a spreader 180. As seen, spreader 180 permits the arms to be moved relatively apart or together. As already discussed above, the movement of the arms apart is
30 performed once the paddles are engaging by suction the surface of the heart to thereby increase epicardial tension locally and thus dampen or decrease the motion

of the surface of the heart due to the intrinsic beating of the heart. Spreader also functions to provide additional stability to paddles due to its function as a truss-like member.

Turning to FIG. 29, spreader 180 comprises a pair of bars 181, 182 which are coupled together using a wing nut 183. One bar features an engagement pin 184 while the other bar features an engagement slot 185. Each bar is further coupled to each of the respective arms of the immobilizing device by a respective lumen 186, 187. In such a manner, each bar is securely coupled to each arm. By longitudinally manipulating each of the bars apart as shown by arrow 188, each arm and thus each paddle may be securely positioned relatively closer or further apart.

FIG. 30 depicts an alternate embodiment of spreader 180. As seen, spreader features a pair of bars which couple to each of the arms of a respective suction device, as described above. Bars are further coupled together using gearing 190. Gearing, in turn, is coupled to a motor 191. As seen, motor is further coupled to a power source 192. Coupling both motor and power source together is a control 193. Control automatically detects the amount of spread within the suction devices caused by spreader. In the preferred embodiment, control senses the amount of power or energy required by motor to further spread spreader and thus suction paddles apart. When a threshold amount is reached, control shuts down the source of power for motor, thereby locking the spreader in the present position. The feature thus permits a spreader to automatically spread the suction paddles apart to a degree sufficient to dampen wall motion without permitting the spreader to spread paddles apart too much such that capture of the heart wall due to suction is lost. Of course, further designs to control the spreading of suction paddles may also be used, such as other mechanical or hydraulic actuated or controlled systems.

FIG. 31 depicts an alternate embodiment of immobilizing device and, in particular, an alternate embodiment of the securing device used to secure each suction paddle. As seen this system features a pair of arms 351, 351 having a ball and socket construction. As seen each arm features at its free end a slip and grip-type holder 12A and 13A as discussed above. The opposite end of each arm fits

into a footing 970, 971. Each footing is lockable to a rail clamp unit 968, 969 which locks onto the rail 901, 902 at the side edges of table 203. Positioned at the bottom of rail clamp unit is locking actuator 967, 968. Each locking actuator cooperates within the arm to thereby cause the arm to be locked into position when the respective handle is turned in one of the directions indicated by arrows 965. In particular locking actuator causes a cable located with the respective arm to tighten, which, due to the ball and socket construction thereby causes the arm to be locked into position. Positioned at the bottom of each locking actuator is a truss. In particular each locking actuator has fixed to it a descending member 216, 217, each of which are linked together by a pair of cross-braces 218, 219. Cross-braces may or may not be coupled together at their center points. As can be appreciated, through this truss construction the stability of anchors and thus the suction devices mounted thereto is increased, as described earlier in FIG. 20A.

FIG. 32 is a cross sectional view of an arm shown in FIG. 31, and in particular showing a detail of the ball and socket construction. As seen only one portion is shown to illustrate the ball and socket construction. Each tube 800 (several of which are used to create arm) has its end fashioned to correspond to the shape of the ball 801, that is each relevant end of tube features a hemispherical hollow having a radius which corresponds to the outer surface of the ball such that a larger portion of the tube contacts the ball as compared to if the end of the tube were only cut straight across. This geometry increases the surface area between the tube and each ball which thereby increases the stability of the arm when fixed into position. Each ball 801 further features an internal bushing 802. As seen each internal bushing is shaped to have a tapered opening 803 at each end. Positioned through the length of arm, and in particular within each tube element and ball is cable 804. Cable is preferably constructed from kevlar and features a polyurethane covering and is fastened to either end of the arm such that by tensioning the cable the ball and tube portions are brought together and fixed in relation due to friction. The operation of arm is as follows. When no tension is placed on the cable, each tube element may slip relatively easily relative to each ball. Tension on the cable, however, increases the friction between tube and ball. Sufficient tension thereby

results in the ball and tube becoming immovable relative to each other. The taper 803 within each bushing 802 permits the cable to remain at the same length regardless of the orientation of each tube element and each ball. That is, if the arm is bent and has a radius of curvature, the taper permits the cable to remain at the same length regardless. This thus permits the arm to be more easily moved and thereafter locked into place.

FIG. 33 depicts a further alternate embodiment of the present invention, and in particular of a suction device substantially similar to that shown in FIG. 13 but for that two separate sets of suction ports are located at the top of the suction paddle. As seen each suction line has a stopcock 861, 862 to permit either or both sets of related suction ports to be independently disconnected from their respective suction source. Arm 823 contains lumens for each suction line and ends where necks 871, 872 begin, As discussed above, each neck is designed to bend. Suction paddle is mounted to necks and as seen features an encircling array of suction ports, located at the upper surface of the paddle relative to the arm. Suction paddle features sixteen suction ports, arranged as a set of eight along one side 81 coupled to one suction line and a second set of eight along another side 82 coupled to another suction line. Through this arrangement even if one side loses capture with the tissue, because the other side is coupled to another suction source, pressure is not lost on that side and capture in that area is maintained. In the embodiment shown the suction ports are located along a generally conical planar surface at the top of the paddle, although other types of planar surfaces may be used, such as frusto-conical for example. The orientation of the suction ports along the top of the encircling paddle is most useful to access the posterior or backside of the heart so as to move or reposition the heart to achieve better access to areas which would otherwise be difficult to access.

To further assist in the exposure of the surgical site, access retractors may also be used in conjunction with the immobilizing device, such as spoon shaped probes to move other tissue from the area of surgical interest.

As disclosed, the present invention relates to a method and apparatus for immobilizing tissue. In the preferred embodiment, the invention is used to

immobilize heart tissue for a coronary artery bypass graft procedure using either an open or closed chest approach, without the need for a cardiopulmonary bypass.

Other surgical techniques, however, which require immobilizing body tissue may also be performed using the present invention, such as surgery on other organs such as the stomach, gall bladder, etc., as well as on other body tissues, such as the eye or the skin, for example. In addition, while the present invention has been described in detail with particular reference to a preferred embodiment and alternate embodiments, it should be understood variations and modifications can be effected within the scope of the following claims. Such modifications may include substituting elements or components which perform substantially the same function in substantially the same way to achieve substantially the same result for those described herein.

5

10

WHAT IS CLAIMED IS

1. A device for temporarily immobilizing an area of tissue comprising:

a suction source;

5 a member having a lumen, the lumen coupled to a suction port, the suction port positioned along a first planar surface of the member, the lumen coupled to the suction source, wherein suction to the lumen is communicated to the suction port; and

means for fixing the member to a stationary object.

10 2. The device of claim 1 wherein the member comprises an arm and a paddle, the paddle coupled to the arm by a hinge.

3. The device of claim 2 wherein the hinge comprises a malleable neck, the neck having a proximal end and a distal end, the distal end coupled to the arm, the distal end coupled to the paddle.

15 4. The device of claim 2 wherein the paddle may be fixed in an angular relationship to the arm by the hinge.

5. The device of claim 1 wherein the member further comprises an arm and a paddle, the paddle coupled to the arm at a first angle.

20 6. The device of claim 1 wherein the member further comprises an arm and a paddle, the paddle movably coupled to the arm at a first angle.

7. The device of claim 1 wherein the first planar surface of the member is curved.

25 8. The device of claim 2 wherein the lumen extending through the arm to the paddle, the lumen further extending through the arm to the suction port, the suction port positioned on the paddle.

9. The device of claim 1 wherein the first planar surface is curved.

10. The device of claim 1 wherein the stationary object is an operating table.

11. The device of claim 1 wherein the stationary object is a retractor.

30 12. A device for immobilizing an area of tissue comprising:
a first member having a suction port along a first plane;

a second member having a suction port along the first plane, the second member positioned apart from the first member such that an immobilized area is defined between;

a securing device to secure the first member and the second member to an immobile object, the securing device coupled to the first member and the second member.

13. The device of claim 12 wherein the first plane is curved.

14. The device of claim 12 wherein the securing device comprises a first variable friction arm having at a first lockable elbow joint and a second first variable friction arm having at a second lockable elbow joint.

15. The device of claim 12 further comprising a first suction source coupled to the first member and communicating with the suction port of the first member and a second suction source coupled to the second member and communicating with the suction port of the second member.

16. A device for immobilizing an area of tissue comprising a member having a suction conduit therein, the suction conduit communicating with a suction port located along a first plane of the member, the suction conduit communicating with the suction port through a suction aperture, the suction port having a suction port diameter, the suction aperture having suction aperture diameter, the suction port diameter being greater than the suction aperture, the suction conduit coupleable to a suction source.

17. The device of claim 16 wherein the suction port diameter is three times greater than the suction aperture.

18. The device of claim 16 wherein the suction port has generally straight, cylindrical sides.

19. The device of claim 16 wherein the member is secured to a stationary object by a securing device.

20. A method of performing open or closed chest cardiac surgery comprising:

accessing a surface of the heart;

positioning a first member having a first suction port on the surface of the heart;

coupling a suction source to the suction port of the first member;

5 creating a suction with the suction source, the created suction then communicated to the first suction port;

grasping the surface of the heart with the suction in the first suction port; and

fixing the first member to a stationary object;.

10 21. The method of claim 20 wherein the step of accessing a surface of the heart comprises a cutting through an intercostal space.

22. The method of claim 20 wherein the step of accessing a surface of the heart comprises inserting an endoscope and a cutting instrument through the chest wall and cutting through the pericardium with the cutting instrument.

23. The method of claim 20 further comprising the steps of:

15 positioning a second member having a second suction port on the surface of the heart;

coupling a suction source to the suction port of the second member;

grasping the surface of the heart with the suction in the second suction port; and

20 fixing the second member to the stationary object.

24. The method of claim 23 further comprising the steps of moving the first member away from the second member. while maintaining the first member and the second member in grasping contact with the surface of the heart.

25. A method of immobilizing an area of tissue comprising:

25 contacting a first suction port on a first paddle to a first surface of tissue;

contacting a second suction port on a second paddle to a second surface of tissue;

30 creating a suction in the first suction port to cause the first suction port to grasp the first surface of the tissue;

creating a suction in the second suction port to cause the second suction port to grasp the second surface of the tissue;

moving the first paddle away from the second paddle;

fixing the first paddle to a stationary object; and

5 fixing the second paddle to a stationary object.

26. A device for temporarily immobilizing an area of tissue comprising:

a suction source;

10 a member having a first surface, a suction port positioned within the first surface, the suction port communicating with the suction source wherein suction from the suction source is communicated to the suction port; and

means for fixing the member to a stationary object.

27. The device of claim 26 wherein the member further comprises a means for dispensing irrigation fluid to an area proximate the member.

15 28. The device of claim 27 wherein the member further comprises a means for removing irrigation fluid dispensed by the means for dispensing irrigation fluid.

29. The device of claim 27 wherein the means for dispensing irrigation fluid further comprise means for dispensing irrigation fluid under
20 pressure.

30. The device of claim 26 wherein the member further comprise means for delivering light to an area proximate the member.

25 31. The device of claim 26 wherein the means for fixing the member to a stationary object. comprises a shaped anchor of a rigid biocompatible material.

32. The device of claim 31 wherein the anchor is fixed to an operating table.

30 33. The device of claim 26 wherein the means for fixing the member to a stationary object. comprises a first and a second shaped anchors of a rigid biocompatible material, the first anchor fixed to a first side of an operating table and the second anchor fixed to a second side of the operating table.

34. The device of claim 33 wherein the first anchor and the second anchor are coupled together by a truss, the truss coupled to each bottom end of each first anchor and the second anchor, the truss positioned below the surgical table.

5 35. The device of claim 33 wherein a retractor is coupled to the first anchor and to the second anchor.

36. The device of claim 35 wherein a mounting rail is coupled to the first anchor and to the second anchor.

37. The device of claim 35 wherein a mounting rail is coupled to the retractor.

10 38. of claim 34 wherein the truss comprises a first descending member fixed to the first anchor and a second descending member fixed to the second anchor, a first and a second brace coupled across each other and fixed to each of the first and the second descending members.

15 39. The device of claim 26 wherein member has a first circular side having a first set of suction ports and a second circular side having a second set of suction ports, the member further having means for permitting the first and the second set of suction ports to be independently connect or disconnected from the suction source.

20 40. The device of claim 26 wherein the suction source has a first suction line and a second suction line, each suction line having a stopcock disposed thereon to selectively permit the transmission of suction along each suction line, each suction line coupled to the member, the member having an arm, the arm having a first lumen into which the first suction line is coupled and a second lumen into which the second suction line is coupled, a first bendable neck coupled to the first lumen and a second bendable neck coupled to the second lumen, and an
25 encircling member, the encircling member having a first circular arm having a first set of suction ports and a second circular side having a second set of suction ports, the encircling member coupled to the first neck and the second neck such that suction in the first line is transmitted to the first set of suction ports and suction from the
30 second line is transmitted to the second set of suction ports.

41. The device of claim 26 wherein the means for fixing the member to a stationary object. comprise a mounting beam, the mounting beam having means for fixing a member to the mounting beam, the mounting beam having a first section and a second section, means for spreading apart the first section from the second section and means for mounting mounting beam to a stationary object.

42. The device of claim 26 wherein the member comprises an arm couple to a member by a bendable section.

43. The device of claim 42 wherein the arm and member are parallel.

44. The device of claim 42 wherein the member is oriented at a ninety degree angle relative to the arm.

45. The device of claim 26 wherein the member has a first and a second suction port positioned within the first surface, the first and the second suction ports communicating with the suction source wherein suction from the suction source is communicated to the first and the second suction ports.

46. The device of claim 26 wherein the member has a first, a second and a third suction port positioned within the first surface in a first linear relationship to each other, the suction ports communicating with the suction source wherein suction from the suction source is communicated to the suction ports.

47. The device of claim 46 further comprising a fourth suction port positioned within the first surface next to the first, the second and the third suction ports positioned within the first surface in the first linear relationship to each other.

48. The device of claim 26 wherein the means for fixing the member to a stationary object. comprises a ball and socket arm.

49. The device of claim 48 wherein the ball and socket arm comprises a first tube coupled at a first end to a spherical ball having a ball radius, the first end having a hemispherical shape with a radius substantially similar to the ball radius.

50. The device of claim 49 wherein the ball has a lumen completely therethrough, a taper bushing position with the lumen, the taper bushing having a

passage way thereout which has a first diameter at a first end, a second diameter in the middle and a first diameter at a end opposite the first end, the first diameter larger than the second diameter.

5 51. The device of claim 26 wherein the means for fixing the member to a stationary object. comprises a ball and socket arm, the ball and socket arm having a series of tube portions jointed together by a series of ball portions, the tube portions having ends which mate with the ball portions, the ends hemispherically shaped to correspond to the ball portions, a cable disposed throughouth the series of ball portions and tube portions, the ball portions having means for maintining the same length of the cable within the arm regardless of the orientation of any tube protion to an adjacent ball portion.

10 52. The device of claim 51 wherein the means for maintining the same length of the cable within the arm regardless of the orientation of any tube protion to an adjacent ball portion comprises a tapered bushing positioned within a lumen of the ball, the tapered bushing having a passage way thereout which has a first diameter at a first end, a second diameter in the middle and a first diameter at a end opposite the first end, the first diameter larger than the second diameter.

53. A device for immobilizing an area of tissue comprising:

a first member having a first suction port ;

20 a second member having a second suction port , the second member positioned apart from the first member such that an immobilized area is defined between;

a securing device to secure the first member and the second member to an immobile object, the securing device coupled to the first member and the second member.

25 54. The device of claim 53 further comprising a means for spreading the first member apart from the second member.

30 55. The device of claim 54 wherein the means for spreading the first member apart from the second member comprise a first bar fixed to the first member and a second bar coupled to the second member, the first having a linear

slot and the second bar having means for engaging the linear slot and fixing the second bar to the first bar.

56. The device of claim 55 wherein the means for spreading the first member apart from the second member comprise motor means coupled to the first member and the second member to cause the first member to move apart from the second member, power means coupled to the motor means to power the motor means, and control means couple to the motor means and the power means to control the operation of the motor means.

57. A device for immobilizing an area of tissue comprising:
a member having a suction conduit therein, the suction conduit communicating with a suction port having a first end, the first end defining a first, the suction conduit communicating with the suction port through a suction aperture, the suction port having a suction port diameter, the suction aperture having suction aperture diameter, the suction port diameter being greater than the suction aperture, the suction conduit coupleable to a suction source.

58. The device of claim 57 wherein the suction port diameter is three times greater than the suction aperture.

59. The device of claim 57 wherein the suction port has an axis, the suction aperture is positioned in a non-coaxial relation with the suction port.

60. The device of claim 57 wherein the suction port has generally straight, cylindrical sides.

61. The device of claim 57 wherein the member is secured to a stationary object by a securing device, the securing device having a ball and socket construction.

Fig. 1

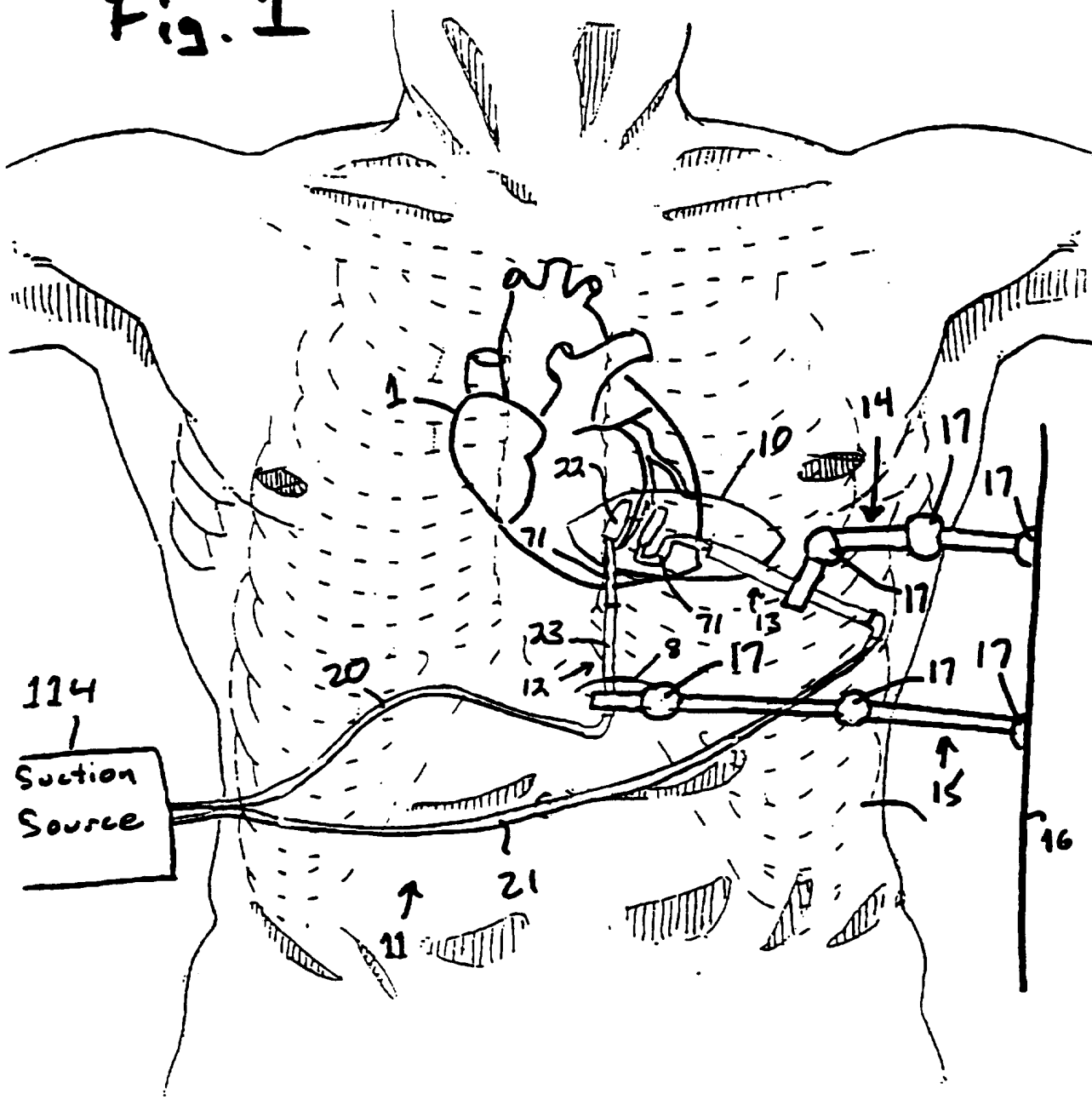

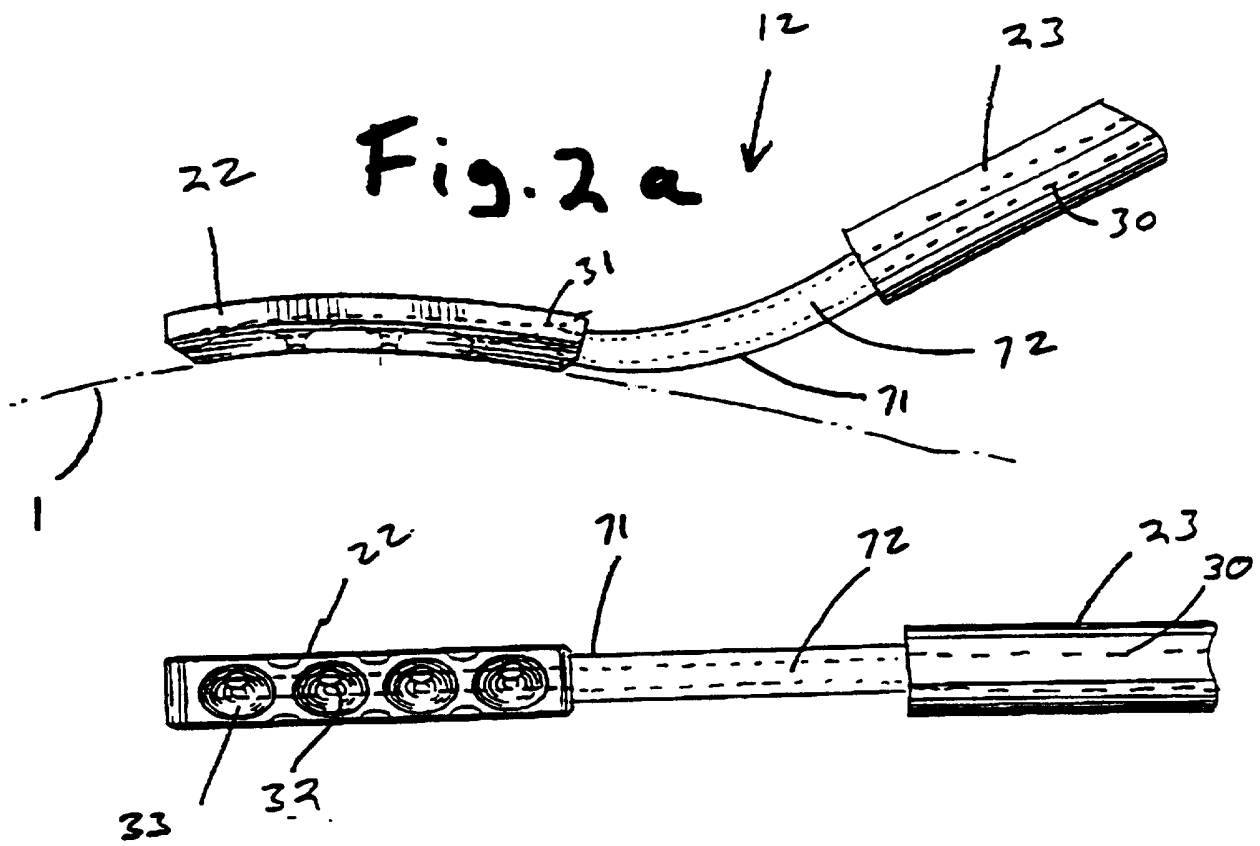

Fig. 2 b

Fig. 3 a

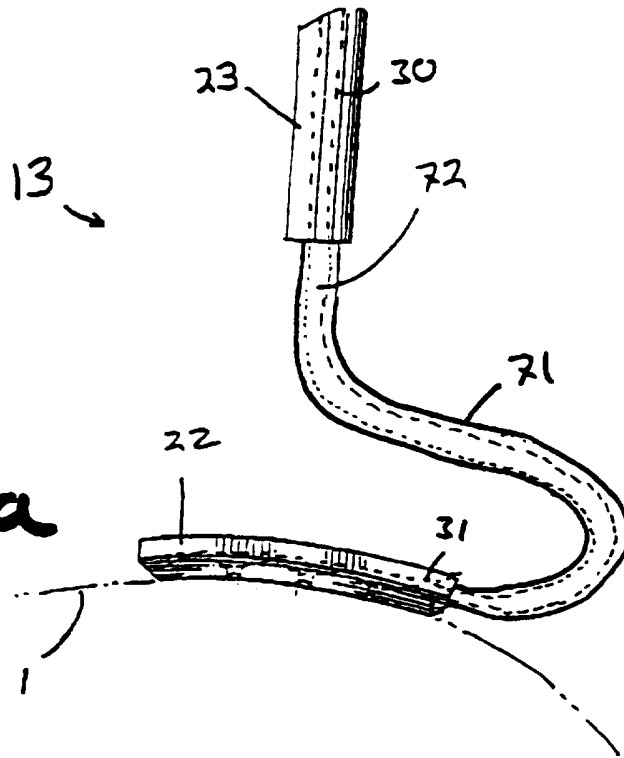
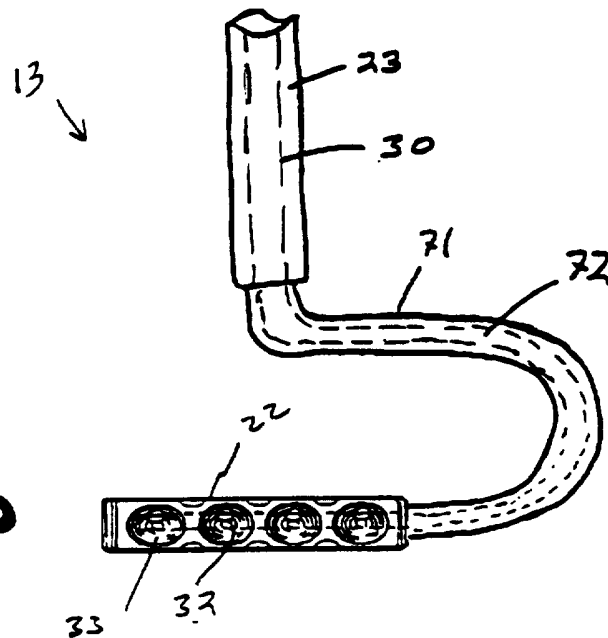

Fig. 3 b



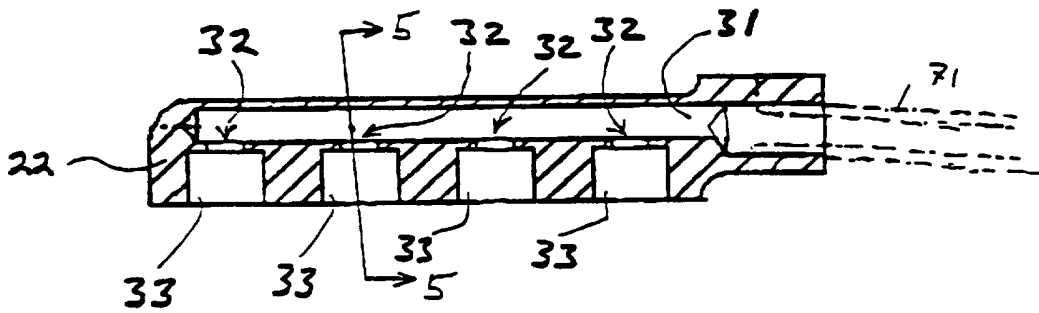
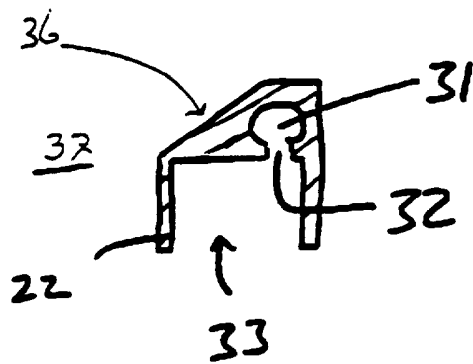

Fig. 4

Fig. 5



5/22

Fig. 7

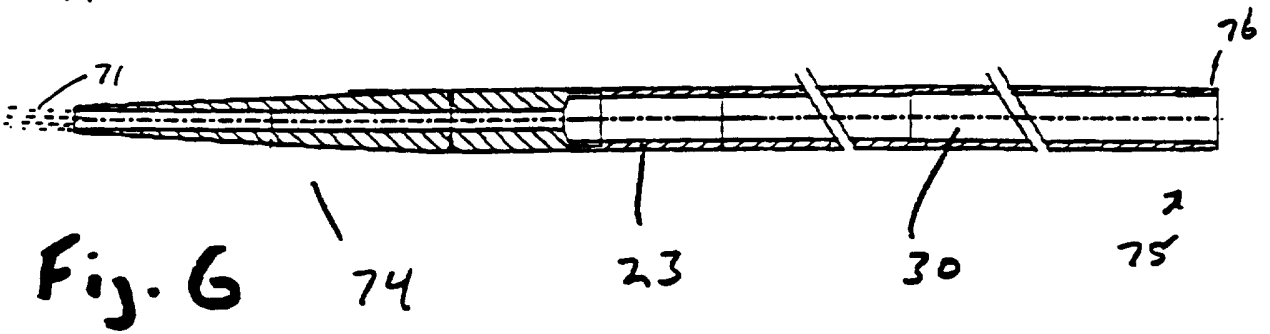
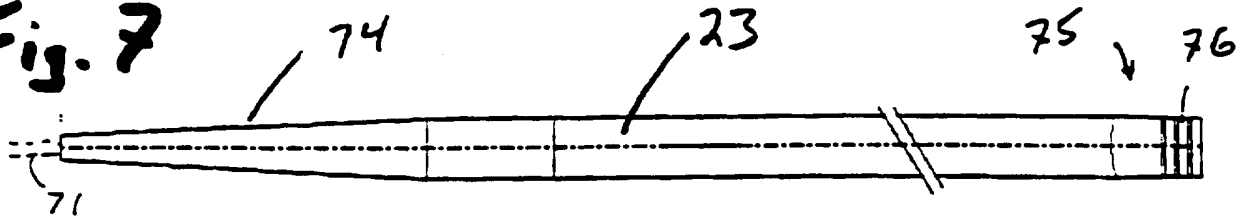

6/22

Fig. 8

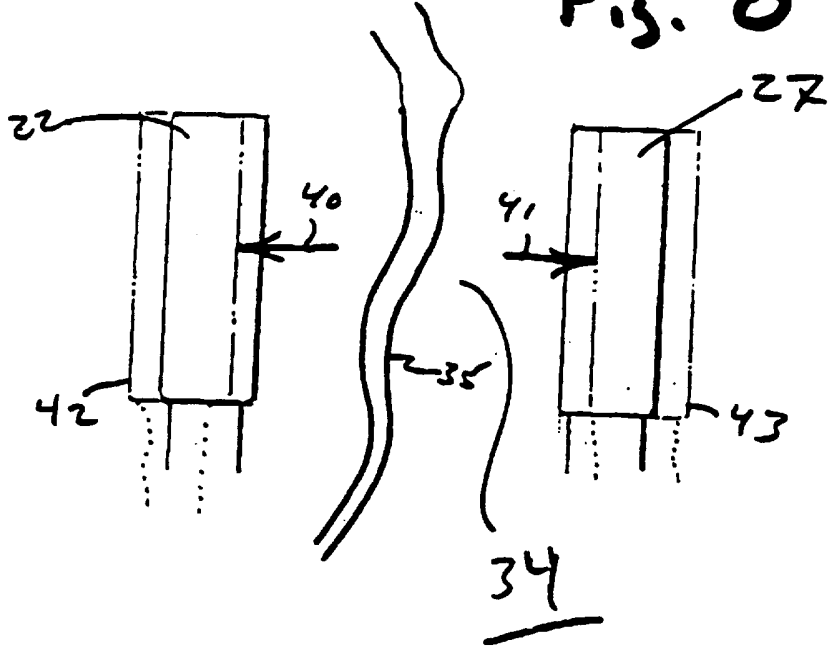

Fig. 9

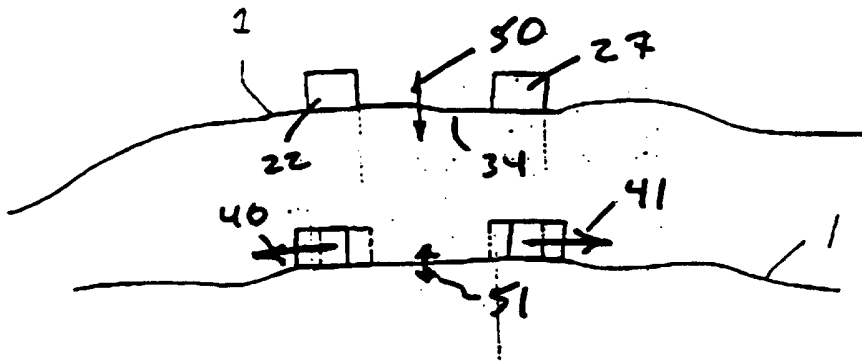

Fig. 10

7/22

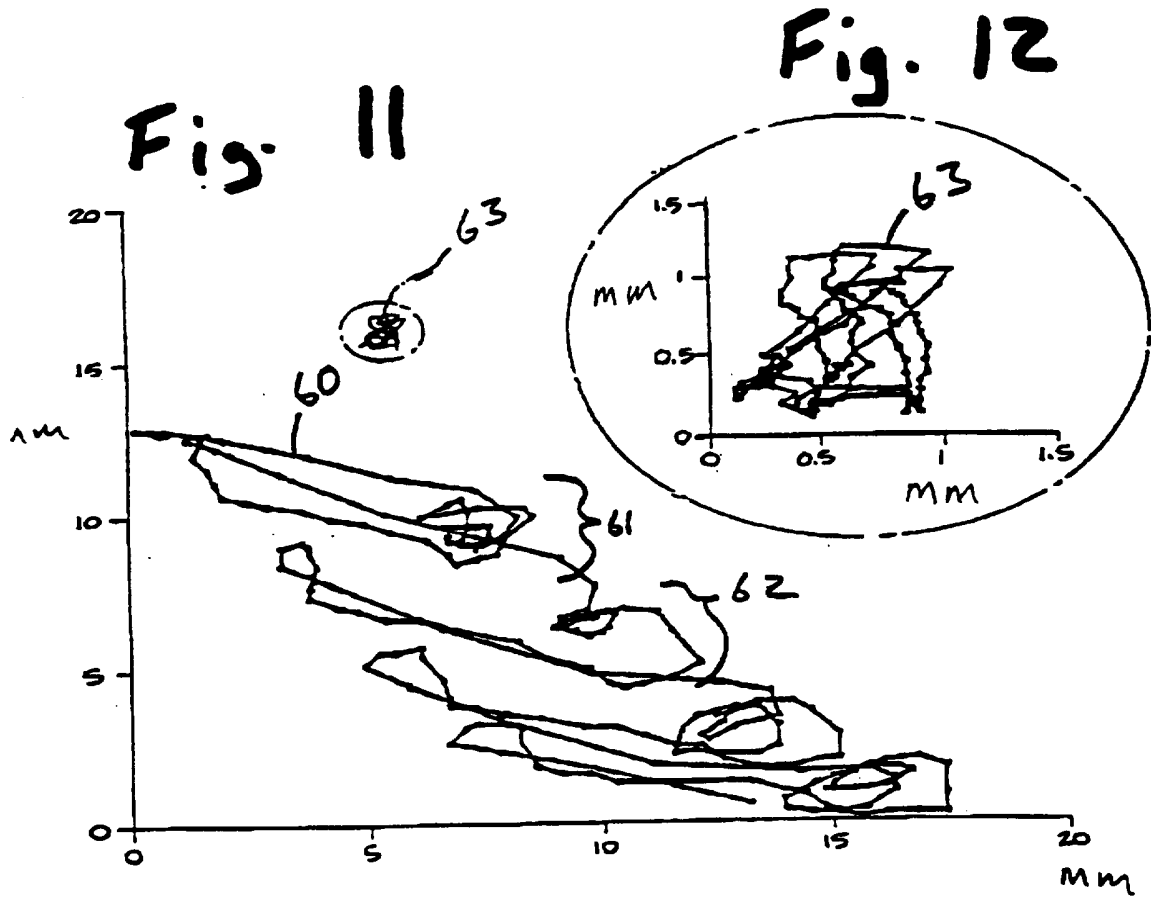

Fig. 12

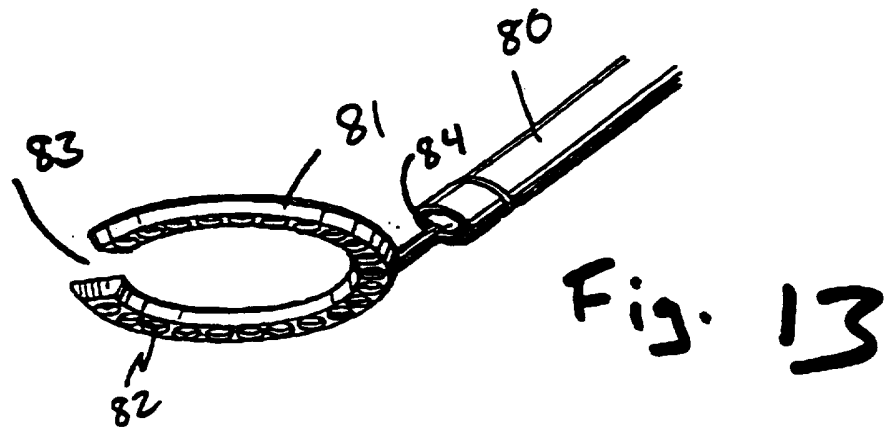
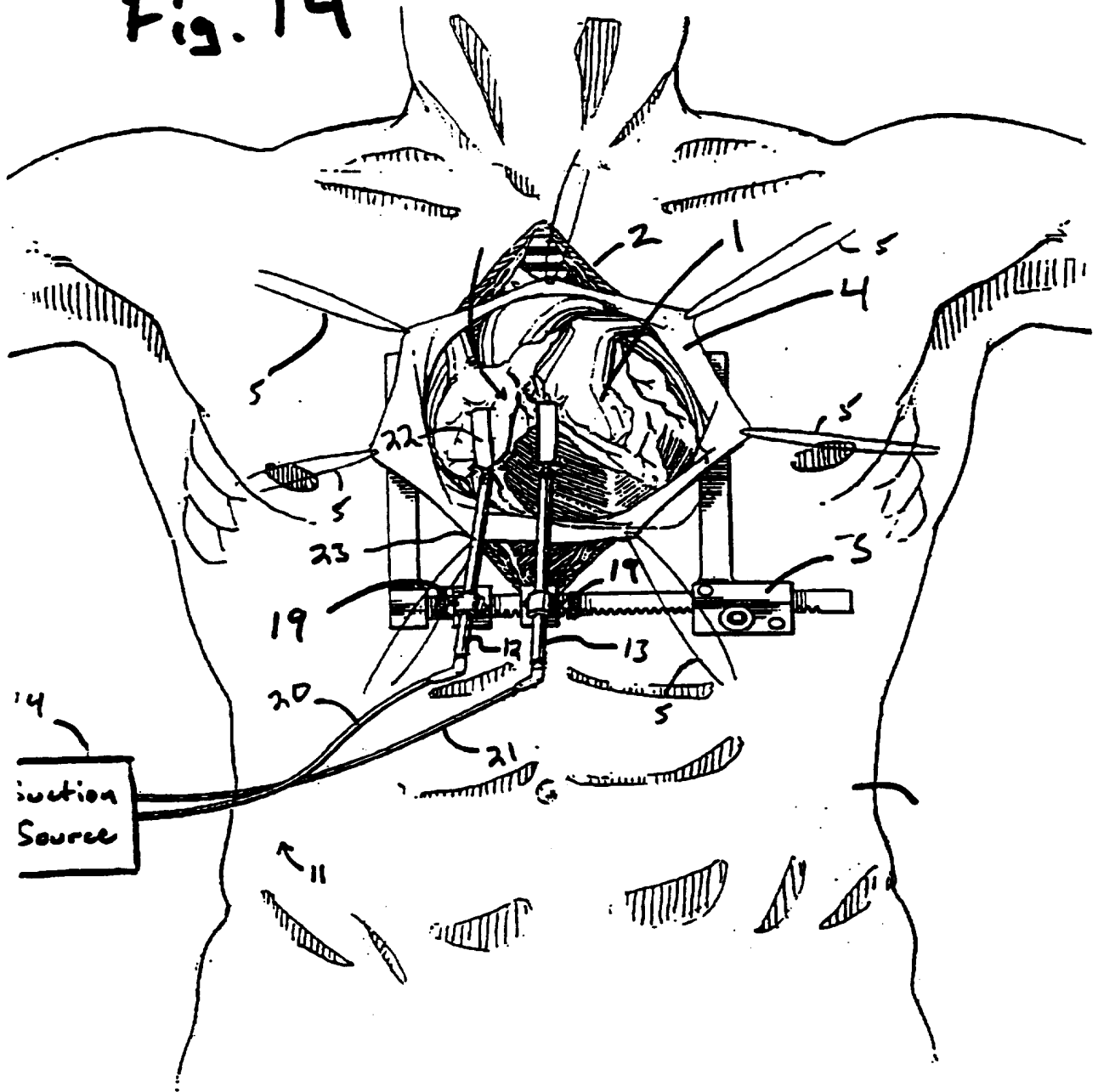

Fig. 13

8/22

Fig. 14



9/22

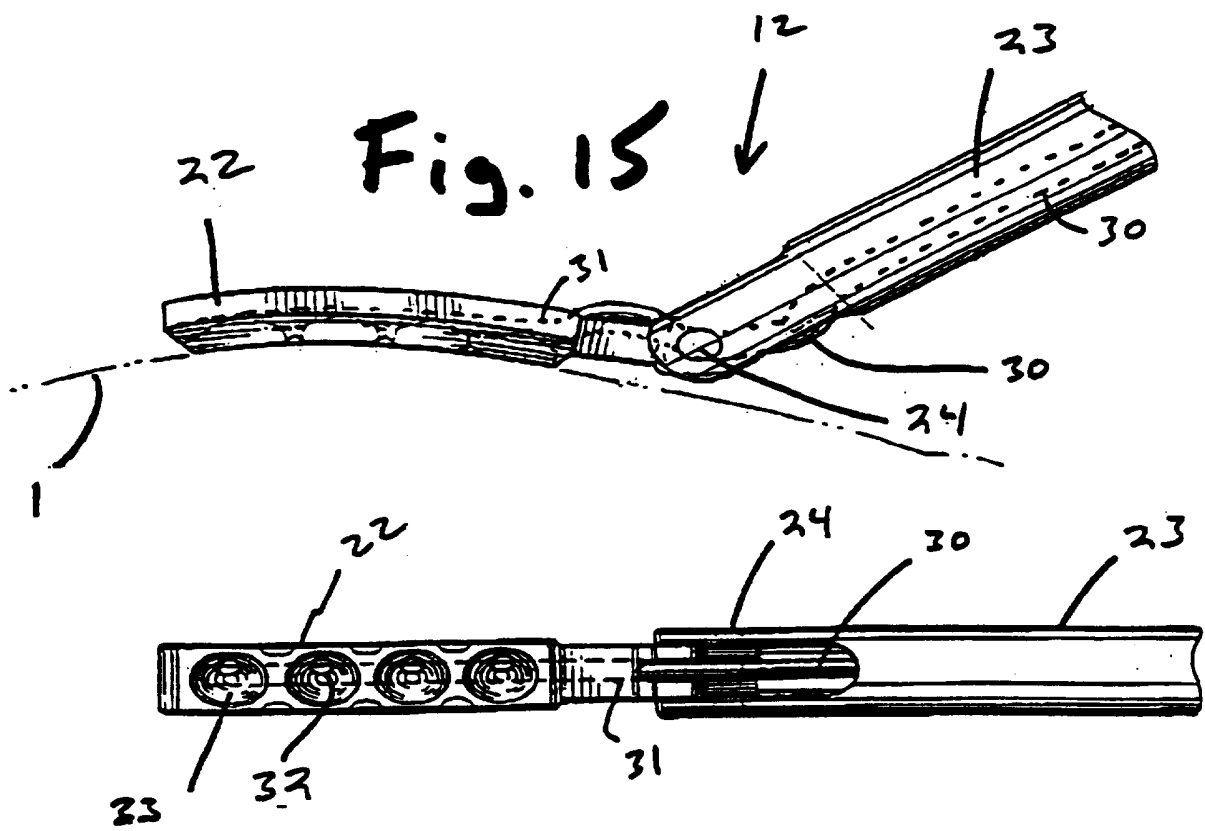
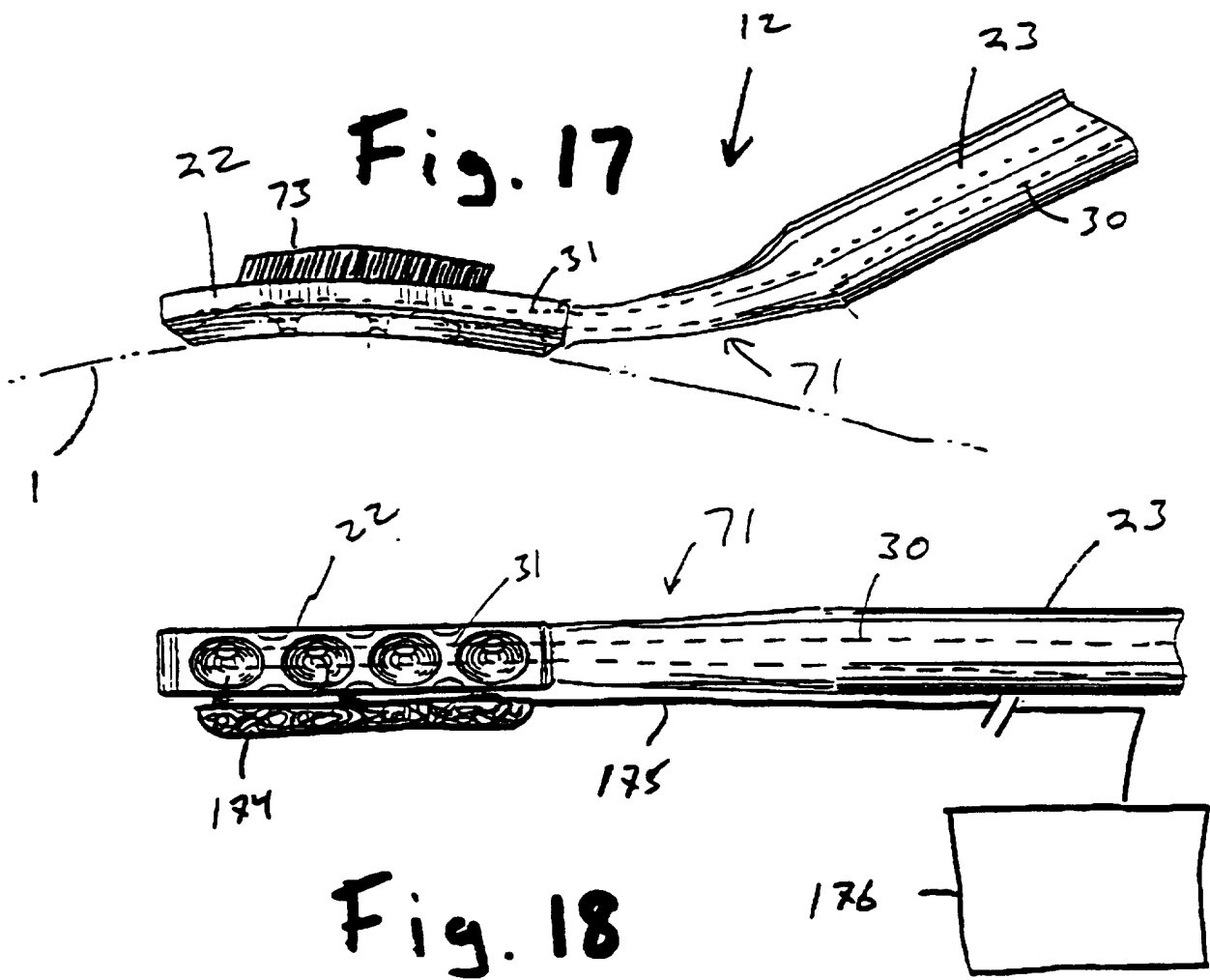

Fig. 16

10/22



11/22

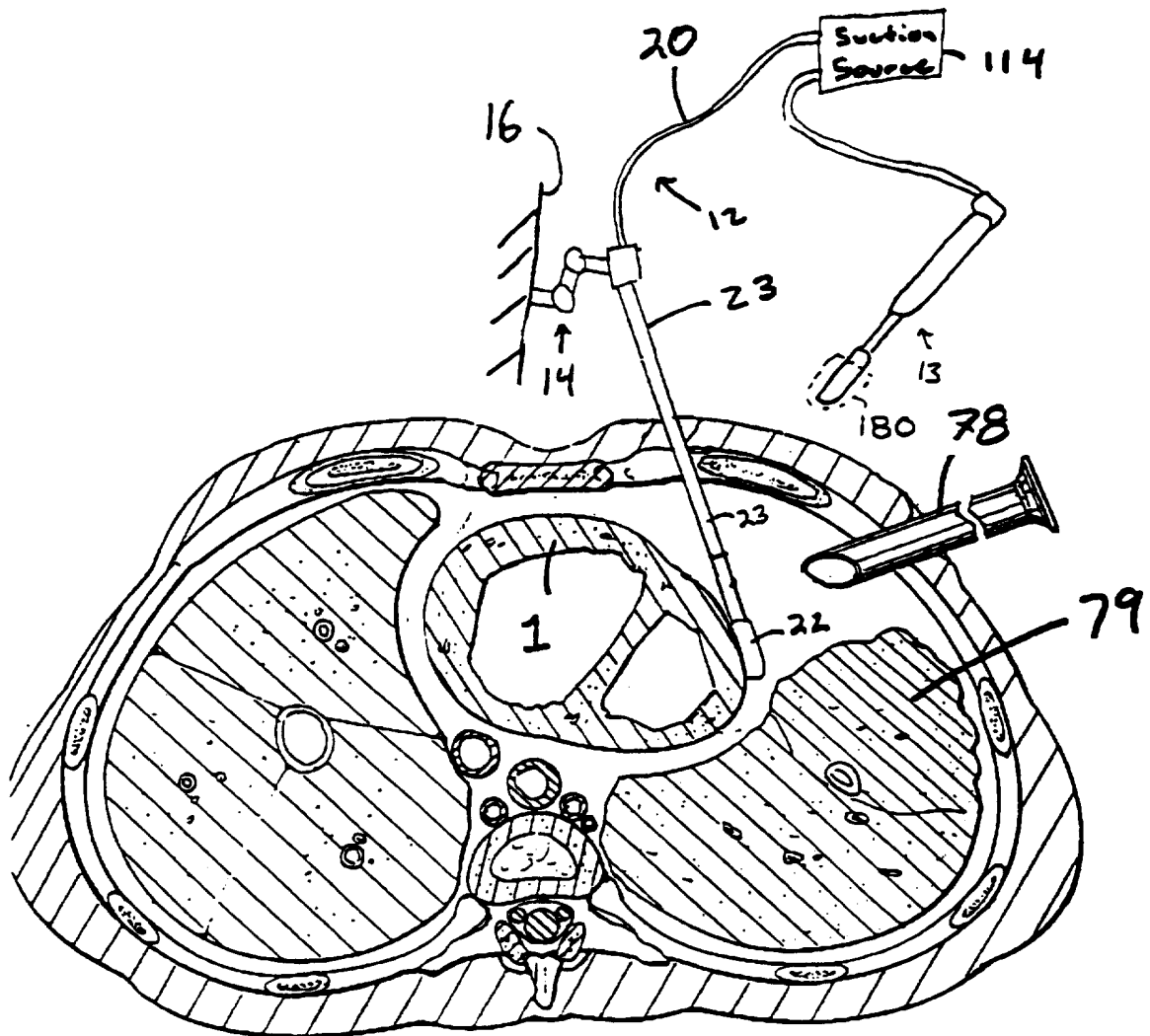

Fig. 19

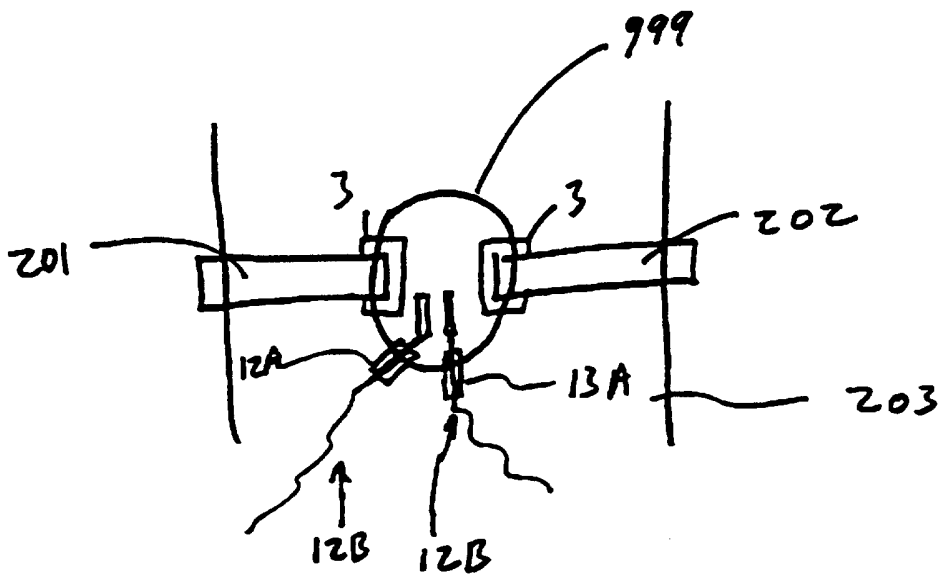

FIG. 20B

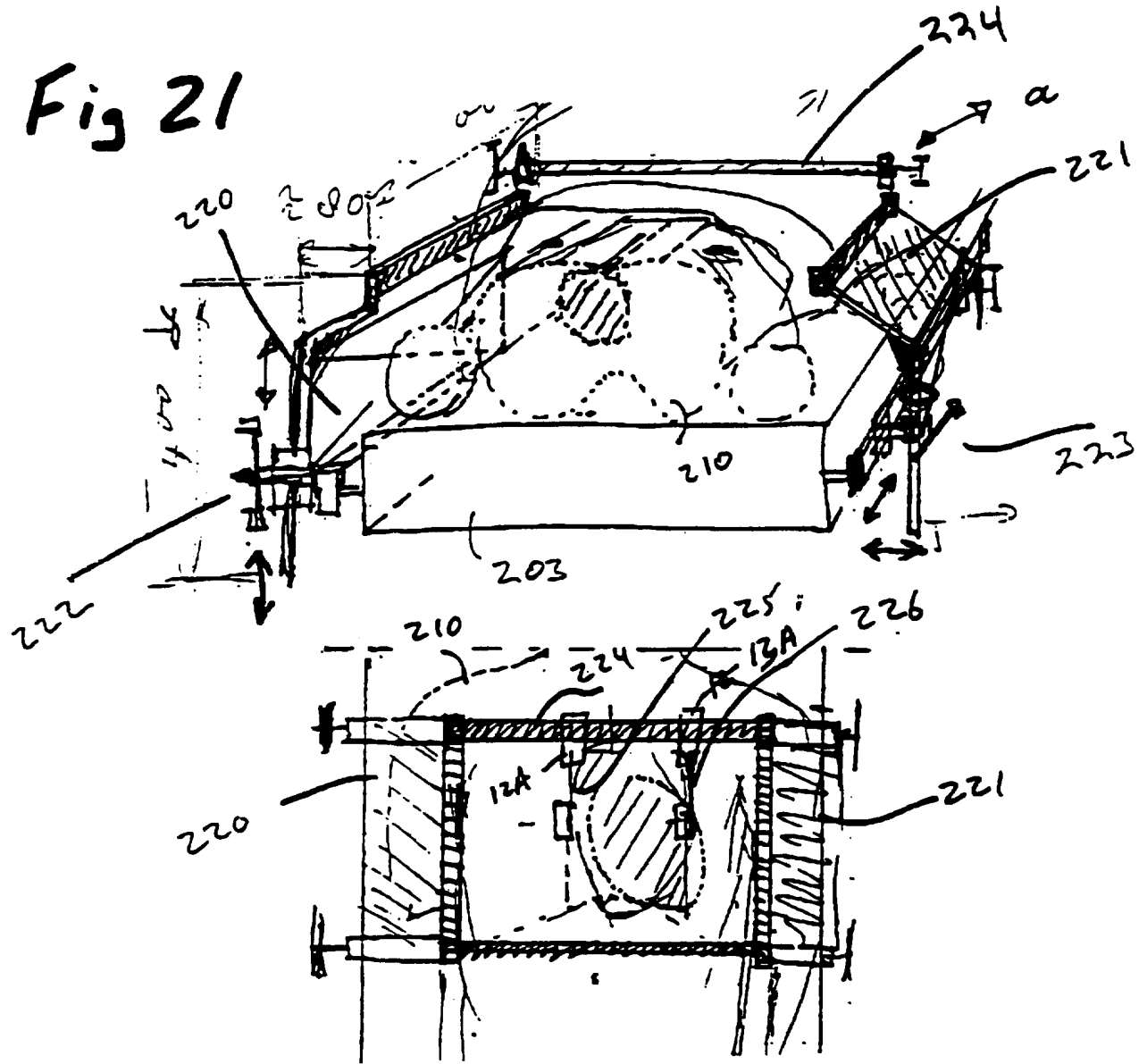

Fig 22

C₁ C₂

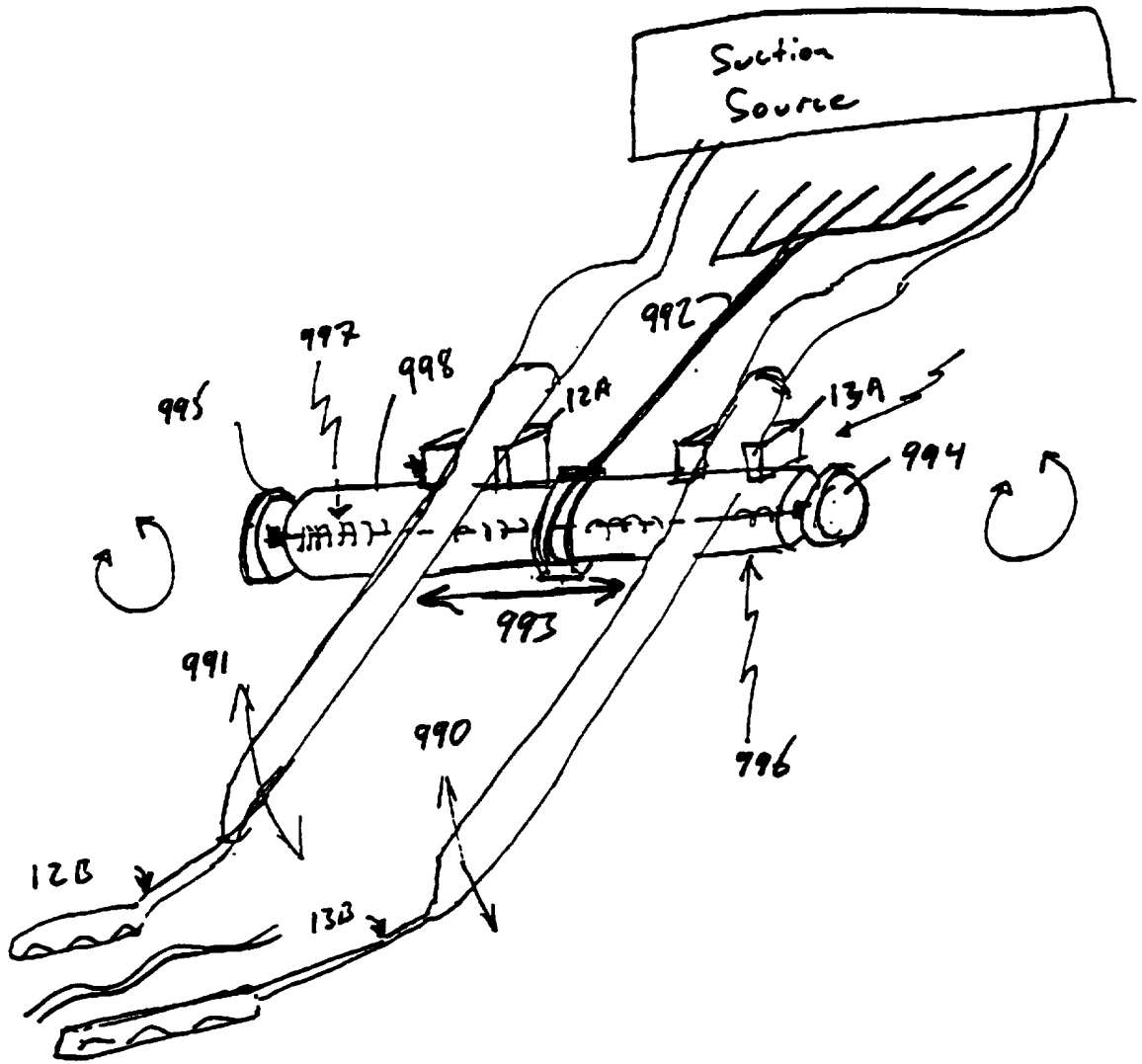

FIG 25

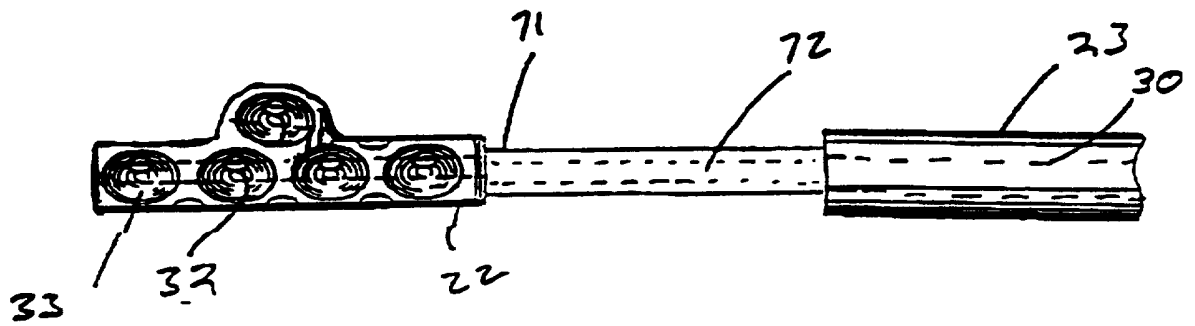

Fig 26 A

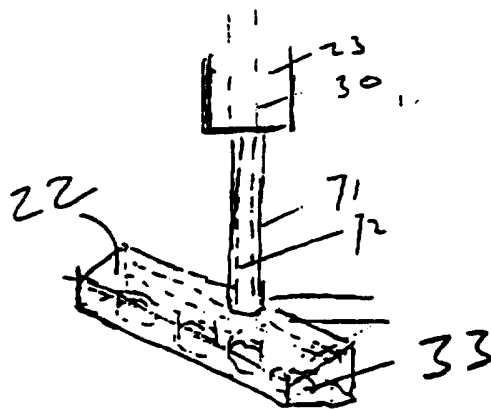

FIG 26 B

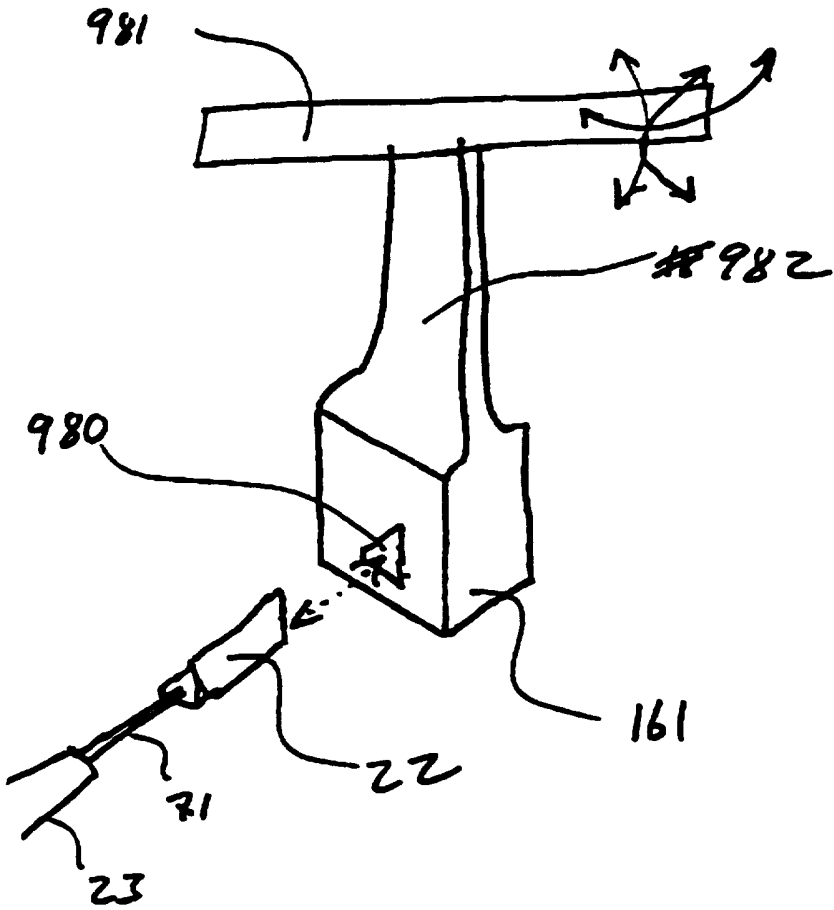

FIG 27

Fig 28

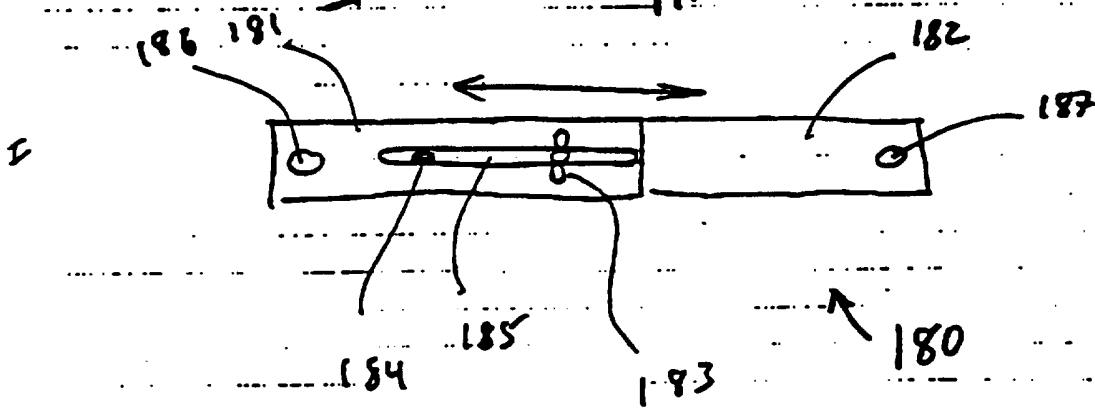
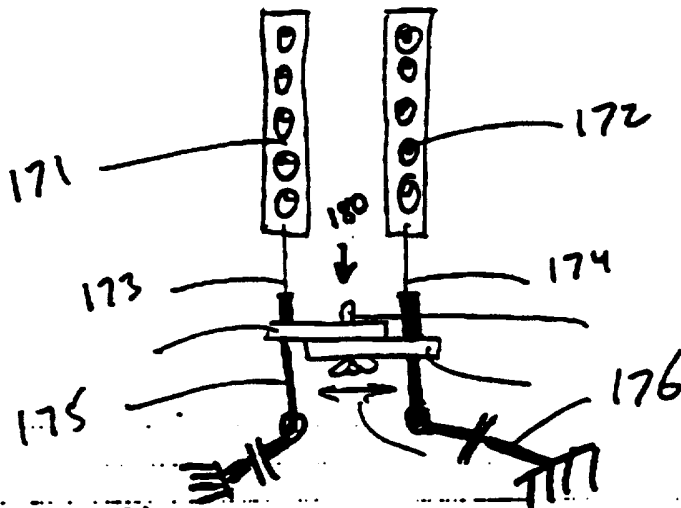
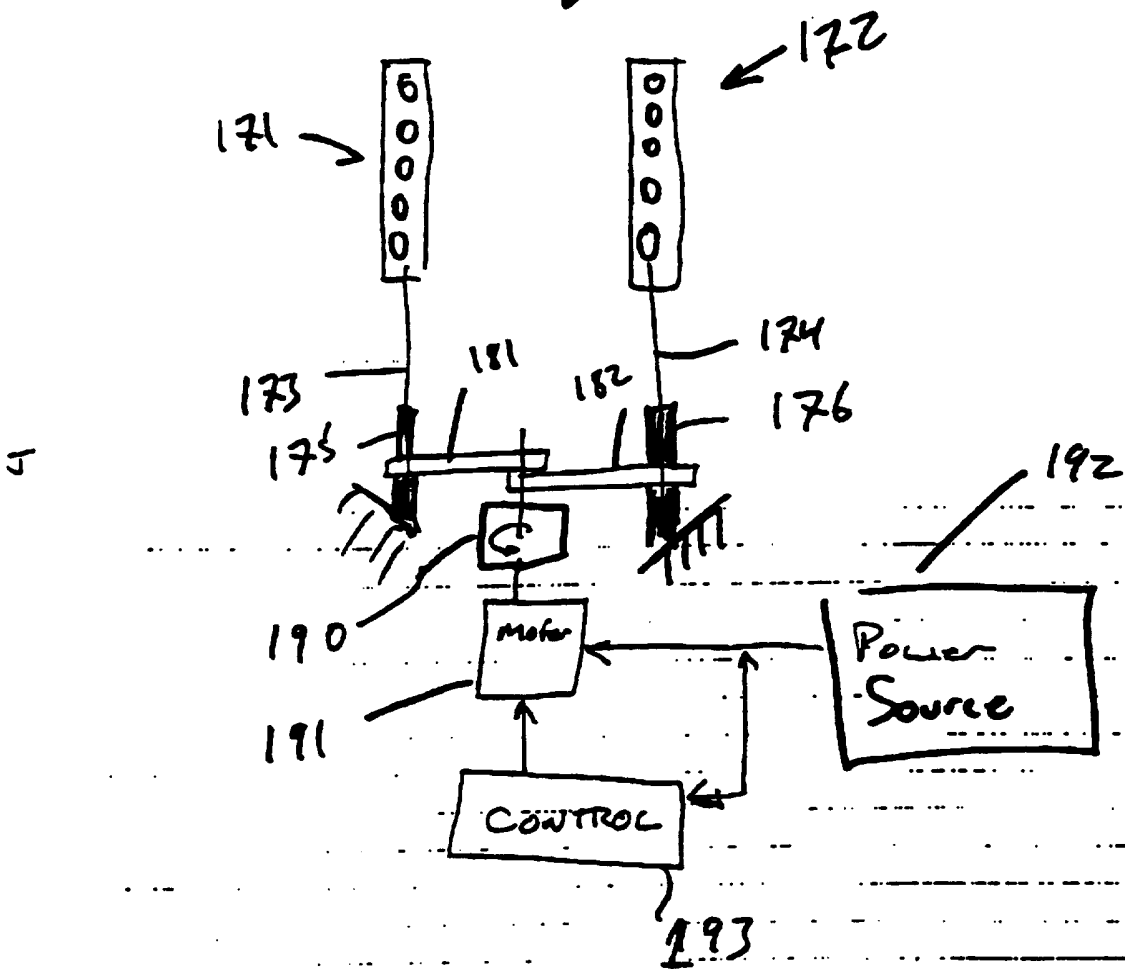

Fig 29

Fig. 30



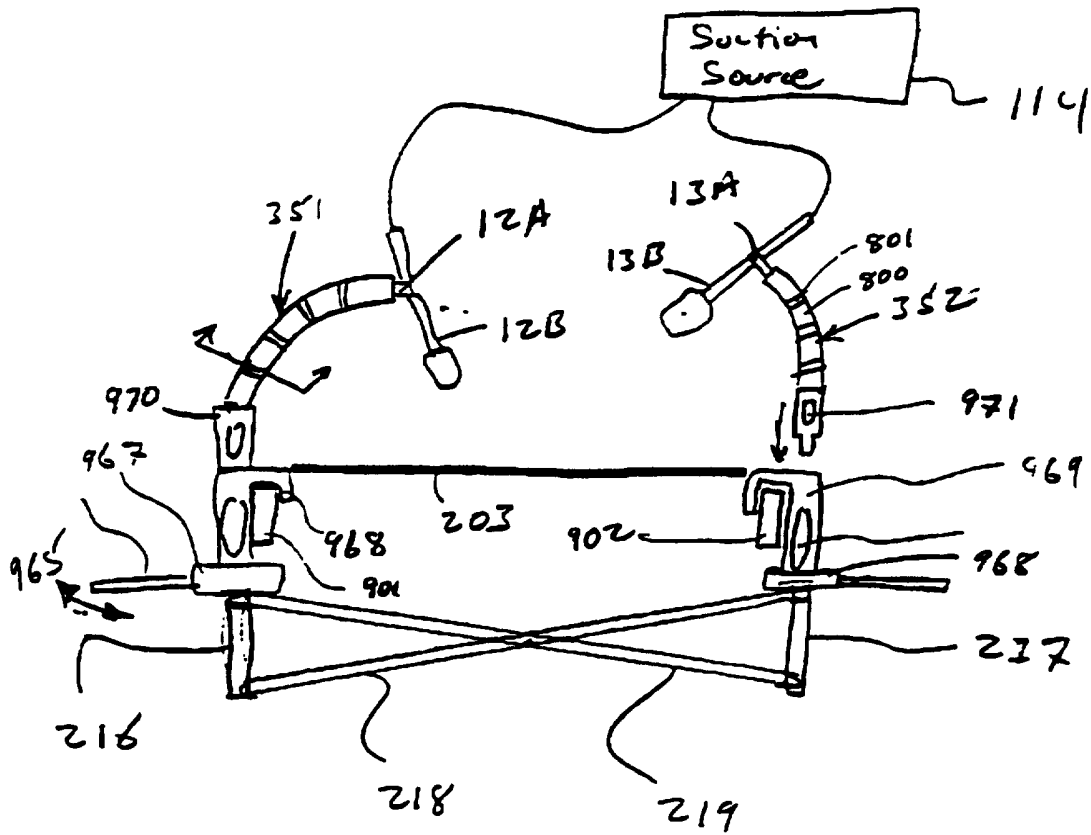

FIG 31

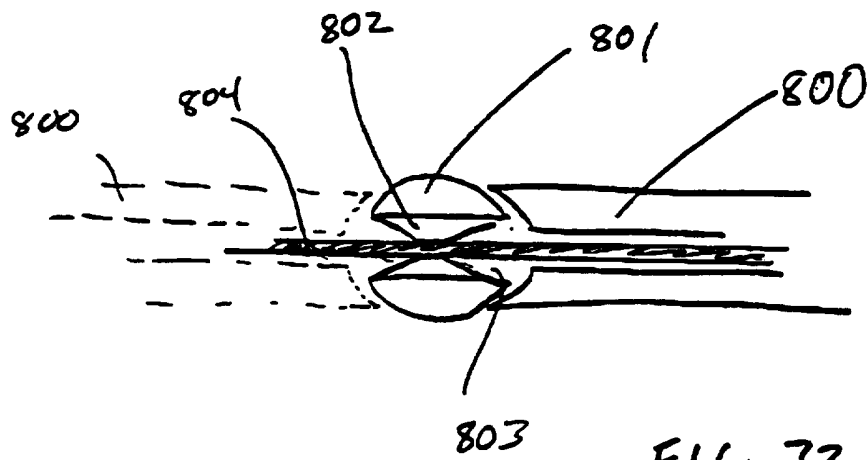

FIG 32

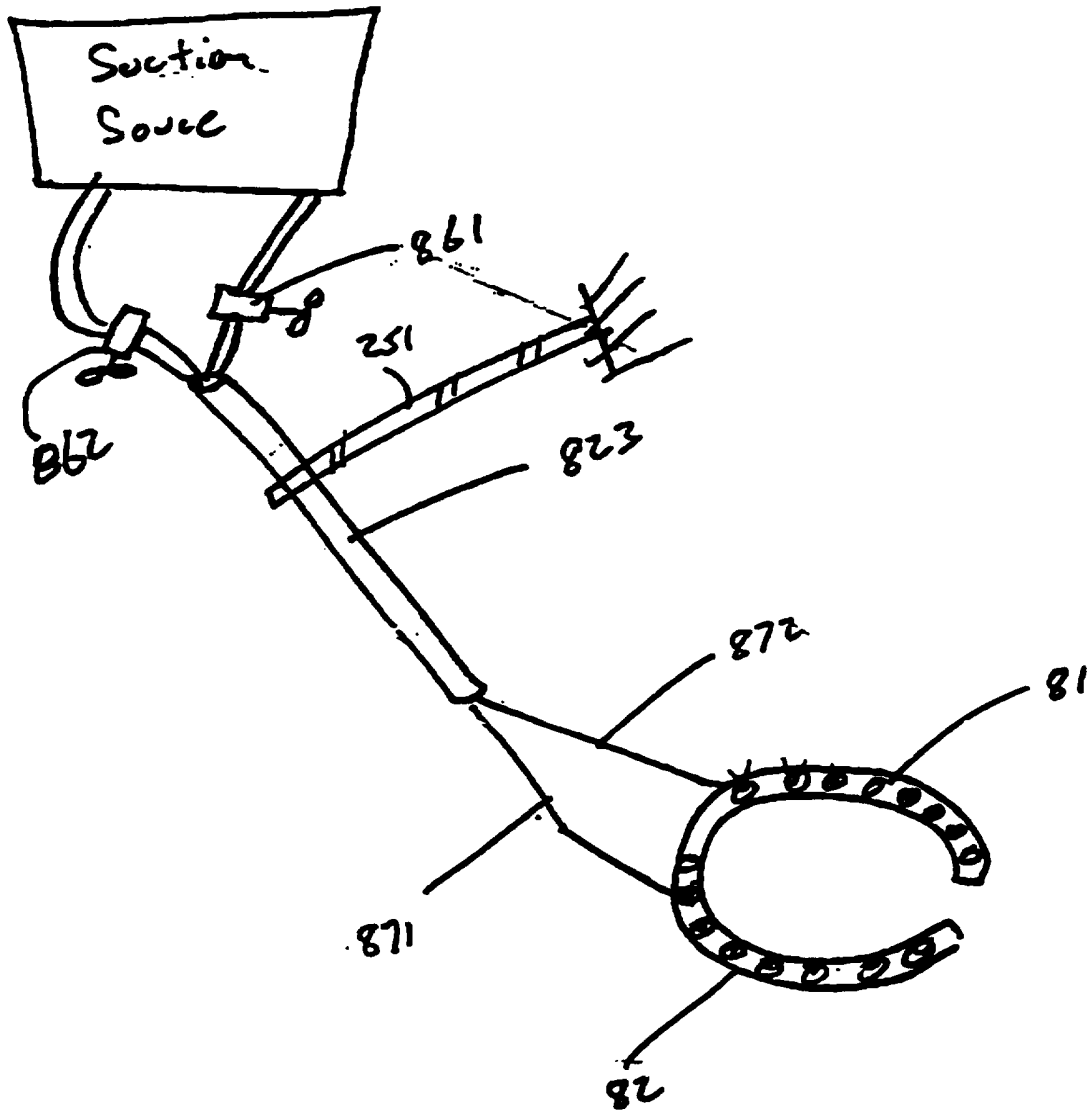

FIG 33

INTERNATIONAL SEARCH REPORT

Internat. Application No
PCT/US 96/15091

A. CLASSIFICATION OF SUBJECT MATTER
IPC 6 A61B17/02 A61B19/00

According to International Patent Classification (IPC) or to both national classification and IPC

B. FIELDS SEARCHED

Minimum documentation searched (classification system followed by classification symbols)
IPC 6 A61B

Documentation searched other than minimum documentation to the extent that such documents are included in the fields searched

Electronic data base consulted during the international search (name of data base and, where practical, search terms used)

C. DOCUMENTS CONSIDERED TO BE RELEVANT

Category *	Citation of document, with indication, where appropriate, of the relevant passages	Relevant to claim No.
X	US,A,5 171 254 (SHER NEAL A) 15 December 1992 see column 2, line 33 - line 62 see column 3, line 53 - line 61 ---	1,10,12, 15-19, 26,39, 41, 45-47, 57-61
Y	US,A,4 047 532 (PHILLIPS JACK L ET AL) 13 September 1977 see column 2, line 40 - line 53 ---	1,5,26, 48,49
Y	EP,A,0 293 760 (LEONARD MEDICAL) 7 December 1988 see figure 2 ---	1,5,26, 48,49
	-/--	

Further documents are listed in the continuation of box C.

Patent family members are listed in annex.

* Special categories of cited documents:

- *A* document defining the general state of the art which is not considered to be of particular relevance
- *E* earlier document but published on or after the international filing date
- *L* document which may throw doubts on priority claim(s) or which is cited to establish the publication date of another citation or other special reason (as specified)
- *O* document referring to an oral disclosure, use, exhibition or other means
- *P* document published prior to the international filing date but later than the priority date claimed

- *T* later document published after the international filing date or priority date and not in conflict with the application but cited to understand the principle or theory underlying the invention
- *X* document of particular relevance; the claimed invention cannot be considered novel or cannot be considered to involve an inventive step when the document is taken alone
- *Y* document of particular relevance; the claimed invention cannot be considered to involve an inventive step when the document is combined with one or more other such documents, such combination being obvious to a person skilled in the art.
- *&* document member of the same patent family

Date of the actual completion of the international search

18 December 1996

Date of mailing of the international search report

08.01.97

Name and mailing address of the ISA
European Patent Office, P.B. 5818 Patentlaan 2
NL - 2280 HV Rijswijk
Tel. (+ 31-70) 340-2040, Tx. 31 651 epo nl,
Fax: (+ 31-70) 340-3016

Authorized officer

Gérard, B

INTERNATIONAL SEARCH REPORT

Internal	Application No
PCT/US 96/15091	

C.(Continuation) DOCUMENTS CONSIDERED TO BE RELEVANT		
Category *	Citation of document, with indication, where appropriate, of the relevant passages	Relevant to claim No.
A	US,A,4 627 421 (SYMBAS PANAGIOTIS N ET AL) 9 December 1986 see column 2, line 21 - line 29; figure 1 ---	11,30
A	US,A,4 637 377 (LOOP FLOYD D) 20 January 1987 -----	

INTERNATIONAL SEARCH REPORT

International application No.

PCT/US 96/15091

Box I Observations where certain claims were found unsearchable (Continuation of item 1 of first sheet)

This International Search Report has not been established in respect of certain claims under Article 17(2)(a) for the following reasons:

1. Claims Nos.: 20-25
because they relate to subject matter not required to be searched by this Authority, namely:
PCT Rule 39.1(iv) Method for treatment of the human body by surgery
2. Claims Nos.:
because they relate to parts of the International Application that do not comply with the prescribed requirements to such an extent that no meaningful International Search can be carried out, specifically:
3. Claims Nos.:
because they are dependent claims and are not drafted in accordance with the second and third sentences of Rule 6.4(a).

Box II Observations where unity of invention is lacking (Continuation of item 2 of first sheet)

This International Searching Authority found multiple inventions in this international application, as follows:

1. As all required additional search fees were timely paid by the applicant, this International Search Report covers all searchable claims.
2. As all searchable claims could be searched without effort justifying an additional fee, this Authority did not invite payment of any additional fee.
3. As only some of the required additional search fees were timely paid by the applicant, this International Search Report covers only those claims for which fees were paid, specifically claims Nos.:
4. No required additional search fees were timely paid by the applicant. Consequently, this International Search Report is restricted to the invention first mentioned in the claims; it is covered by claims Nos.:

Remark on Protest

- The additional search fees were accompanied by the applicant's protest.
- No protest accompanied the payment of additional search fees.

INTERNATIONAL SEARCH REPORT

Information on patent family members

Internat Application No

PCT/US 96/15091

Patent document cited in search report	Publication date	Patent family member(s)	Publication date
US-A-5171254	15-12-92	AU-B- 660891 AU-A- 3139293 BR-A- 9206774 CA-A- 2123911 EP-A- 0613350 JP-T- 7501247 WO-A- 9309719	06-07-95 15-06-93 07-11-95 27-05-93 07-09-94 09-02-95 27-05-93
-----	-----	-----	-----
US-A-4047532	13-09-77	NONE	
-----	-----	-----	-----
EP-A-0293760	07-12-88	US-A- 4863133 DE-D- 3853020 DE-T- 3853020	05-09-89 23-03-95 14-09-95
-----	-----	-----	-----
US-A-4627421	09-12-86	NONE	
-----	-----	-----	-----
US-A-4637377	20-01-87	NONE	
-----	-----	-----	-----