

The specification in this patent
is not in print.

L. Ball,

Railroad Rail,

N^o 19,675,

Patented Mar. 23, 1858.

Fig. 2

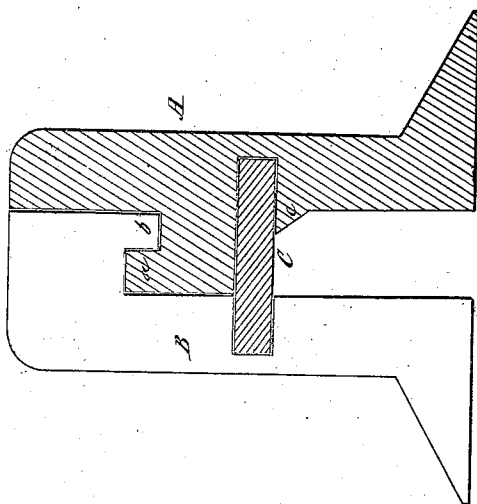
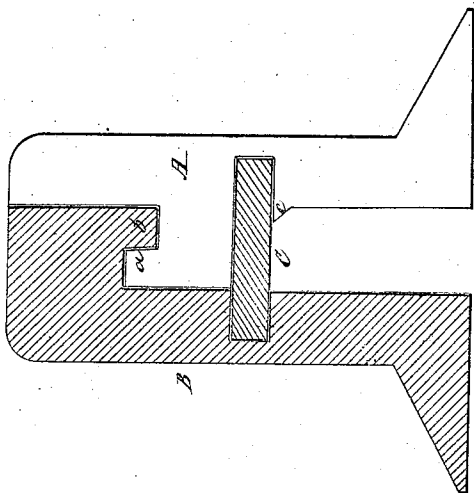

Fig. 1



UNITED STATES PATENT OFFICE.

LEVERETT BALL, OF AUBURN, NEW YORK.

RAILROAD-RAIL.

Specification of Letters Patent No. 19,675, dated March 23, 1858.

To all whom it may concern:

Be it known that I, LEVERETT BALL, of Auburn, in the county of Cayuga and State of New York, have invented a new and Improved Mode of Preventing the Sections of Compound Rails of Railroads from Separating Through Their Whole Length; and I do hereby declare that the following is a full and exact description thereof, reference being had to the accompanying drawings and to the letters of reference marked thereon.

My invention consists in a short plate, inserted crosswise within a compound rail for binding the sections firmly together, like a continuous solid rail.

In the accompanying drawings, Figures 1 and 2 represent two different cross sections of the same rail through the two different section joints.

My rail is divided throughout its whole length into two sections, A and B. These sections, when united, form a bridge-rail, locked together through their whole length by the projections *a*, *b*. The broader section B is placed upon the inside of the track for a common wheel to work against and by means of the lock *a*, *b*, the weight of the cars is in part thrown upon the outer rail A, which is thicker below the lock. The main section B should be thicker and heavier below the plate C than the outer section. The drawings show only the right hand rail of the track. For the left hand rail, the two sections must be reversed when they are laid down, so that two sections B, shall form the inside of both rails of the track. The two sections A and B are laid down so as to break joints in the usual way. The plate C is inserted both at the middle and the ends of every section A and also of B. This plate C is about $1\frac{3}{4}$ inches in length and in width, and $\frac{1}{2}$ of an inch in thickness. These dimensions may be somewhat varied however without departing from my invention. The plate C locks into the ends of two sections A, confining them to the middle of the section B. In like manner the next plate C locks the ends of two sections B and confines them to the middle of a section A.

This plate C must be inserted when the rails are being laid. It renders it impossible for the ends of the sections to rise above the middle of the other section to which they are locked.

When laid down, my rail is self locked so that no section can be removed without tearing up a considerable length of the track.

The rail A is made with a shoulder, *e*, extending the whole length of the rail, for the purpose of better supporting the main rail B.

My rail when put together, is about 5 inches high, $2\frac{3}{4}$ inches thick, with the bottom spread 6 inches wide. The inside section A is twice as thick on the top as the section B. The lips, *a*, and *b*, are $\frac{3}{8}$ of an inch in thickness and in depth, as will be better understood from the drawings. The main rail B should measure 2 inches down to the bottom of the lip *b*, so as to give sufficient strength.

My invention saves a great expense which is usually incurred in bolting compound rails together. It also prevents the disadvantages of the bolts working loose and separating of the two sections of the rail.

A track formed of my rails is very even and consequently the employment of such rails will save a great expense in the wear and tear of machinery.

Should it be desirable to employ wheels with outer flanges, then the main sections B are to be placed upon the outside of the track.

Having thus fully described my invention, what I claim and desire to secure by Letters Patent of the United States is:

The use of plates, inserted at the middle and ends of the sections of compound rails in combination with said sections, locked together throughout their whole length, thus binding the rail together like a solid continuous rail; the whole being constructed and arranged substantially as set forth for the purposes specified.

LEVERETT BALL.

Witnesses:

HORACE T. COOK,
C. N. SITTNER.