

[54] HERMAPHORODITE ELECTRICAL CONNECTOR

[72] Inventor: George S. Johnson, Canoga Park, Calif.
[73] Assignee: International Telephone and Telegraph Corporation, New York, N.Y.
[22] Filed: Oct. 30, 1970
[21] Appl. No.: 85,361

[52] U.S. Cl. ....339/49 R, 339/65, 339/176 M, 339/217 S
[51] Int. Cl. ....H01r 25/00
[58] Field of Search ....339/47, 48, 49, 176, 210, 217 R, 339/217 S, 258, 256, 198, 65, 66

[56] References Cited

UNITED STATES PATENTS

Table with 3 columns: Patent Number, Date, Inventor/Assignee, and Classification. Rows include Averill (1,237,857), Winkler (3,218,599), Ruehleman et al (3,289,145), and Krehbiel (2,938,190).

FOREIGN PATENTS OR APPLICATIONS

966,887 8/1964 Great Britain .....339/49 R

Primary Examiner—Marvin A. Champion
Assistant Examiner—Terrell P. Lewis
Attorney—C. Cornell Remsen, Jr., Walter J. Baum, Paul W. Hemminger and Thomas E. Kristofferson

[57] ABSTRACT

An electrical connector formed of an insulating member having a plurality of contact passageways. The passageways have an enlarged slotted section which divide each passageway into a first portion and a second portion. A contact terminal inserted in the passageway contains a pair of folded sections whose width is less than the width of the first portion but greater than the width of the second portion. A mounting flange portion which is formed adjacent a mating surface section of one of the folded sections of the contact terminal is insertable in the slotted section and one folded section is positioned in the first portion of the passageway. The insulator member is matable with a second identical insulator member utilizing identical contacts. The contacts are removably mounted in the housing.

2 Claims, 6 Drawing Figures

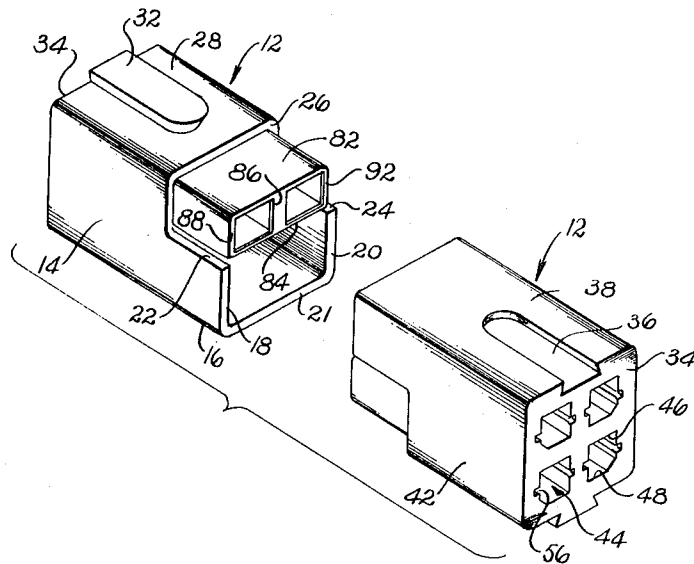

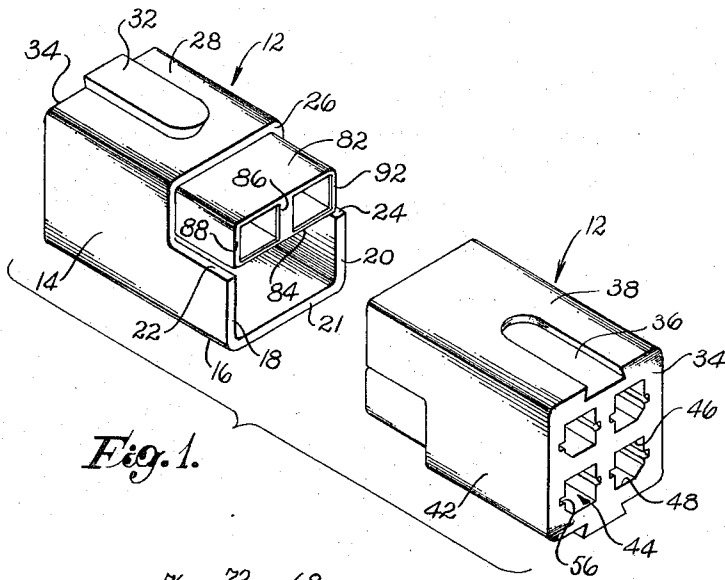

Fig. 1.

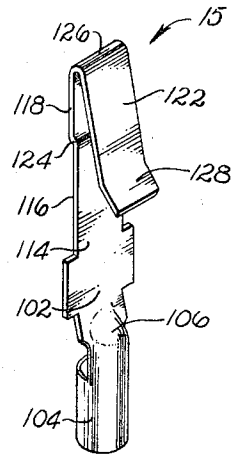

Fig. 2.

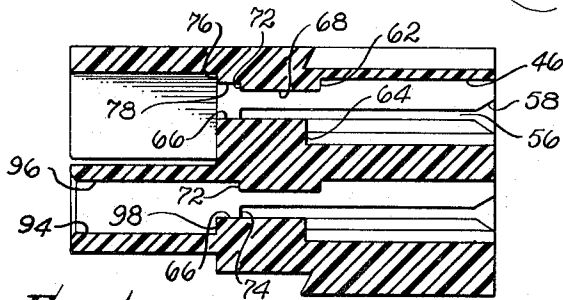

Fig. 4.

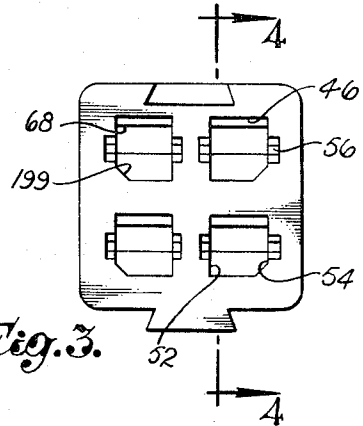

Fig. 3.

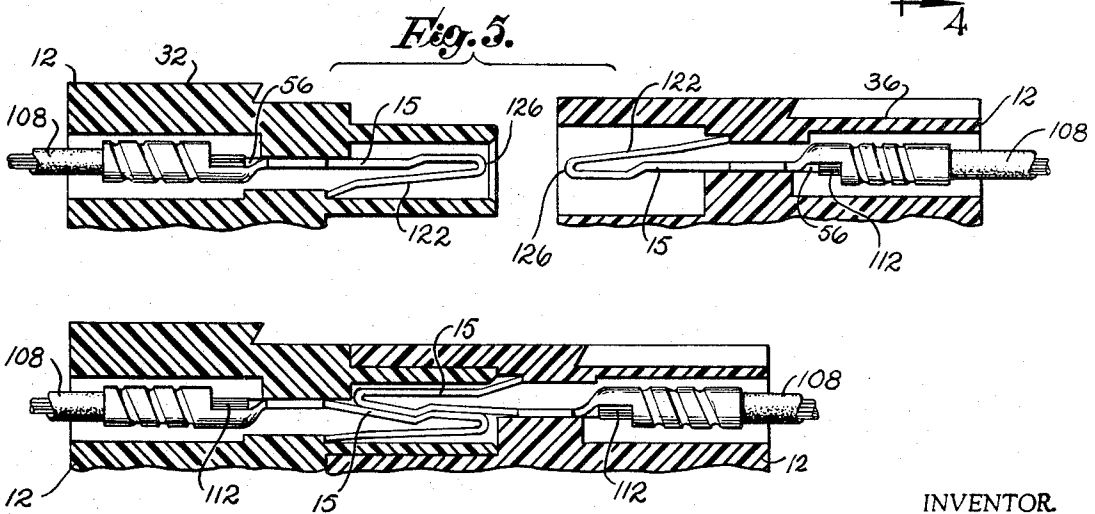

Fig. 6.

INVENTOR  
GEORGE S. JOHNSON  
BY *Harvey S. Hertz*  
ATTORNEY

## HERMAPHORODITE ELECTRICAL CONNECTOR

The invention relates in general to hermaphrodite electrical connectors and, more particularly, to a pair of electrical connectors formed of a single block of insulating material and a plurality of contacts mounted therein, of single piece construction.

## BACKGROUND OF THE INVENTION

With the advent of pre-fabricated housing construction it has been found that certain economies can be achieved by having room partitions pre-wired. Thus, adjacent partitions can be interconnected by pre-wired paneling, minimizing the need for an electrician during construction of the housing. Conventional prior art electrical power connectors previously have either been too complex and, thus, raising the cost of the housing construction, or did not provide the reliability necessary in housing construction which was required. A typical prior art electrical connector having identical male and female portions is depicted in U.S. Pat. No. 3,072,340. These connectors contained a plurality of modules which are identical for the male and female mating members. However, the structure of the insulator housing is relatively complex, requiring a high degree of molding skill. Moreover, the contact utilized in this housing was not sufficiently supported in the connector housing to provide the desired degree of mating reliability. The contact surfaces of the mating contact were both free standing and, thus, it was uncertain as to whether or not desired mating of the contacts would occur.

In order to overcome the attendant disadvantages of prior art hermaphrodite construction in electrical connectors, the present invention utilizes relatively simple insulator construction which can be easily molded at a very low cost. Moreover, the contacts utilized in the connector are of relatively simple construction and may be easily stamped out of conventional conductive material. The contact is mounted and supported in the housing so as to readily provide the desired contact reliability by the mating of the contacts. Moreover, the contacts can be removed from the housing so that conductors can be secured to the contacts externally of the connector housing.

The advantages of this invention, both as to its construction and mode of operation will be readily appreciated as the same becomes better understood by reference to the following detailed description when considered in connection with the accompanying drawings.

## BRIEF DESCRIPTION OF THE DRAWINGS

FIG. 1 depicts a perspective view showing a pair of the hermaphrodite connector members in axially aligned, opposed relationship, ready to be engaged with each other;

FIG. 2 illustrates a perspective view of a preferred contact terminal employed in the present invention before attachment of a conductor thereto, as by crimping;

FIG. 3 shows a rear elevation of one of the connector members of FIG. 1;

FIG. 4 is a vertical section of the connector housing taken along the line 4—4 of FIG. 3;

FIG. 5 illustrates a fragmentary vertical section illustrating a pair of opposed axially aligned insulator members with the contact terminals operatively positioned therein; and,

FIG. 6 shows a sectional view similar to FIG. 5 with the insulator connector members and connector terminals operatively interengaged.

## DESCRIPTION OF THE PREFERRED EMBODIMENT

Referring now to FIG. 1, there is shown a pair of connector housing members 12 adapted to be mated with each other. Each of the members 12 are identical and are illustrated in FIG. 1 with their front ends adjacent to each other, but rotated 180° with respect to each other. Each of the connector members 12 are depicted as having a generally square outer housing portion 14 for positioning contact terminals 15 of the type as shown in FIG. 2. It should be understood, of course, that

while the housing member 14 is square, other configurations, of course, are possible should it be desired to mount six contact members in the housing the shape could vary and the housing would be rectangular. The housing members are made of thermoplastic material or other non-conductive or insulating type materials, which can be easily molded.

The front top half of the housing shown on the left side of FIG. 1 is removed so as to leave a generally U-shaped front portion 16 of the housing having a pair of side walls 18, 20 and a bottom wall 21. Of course, when the member 12 is rotated 180 degrees as shown on the right side of FIG. 1, the front bottom half of the connector would appear to be removed. The side walls 18, 20 terminate at a rearwardly extending surface 22, 24, the surface extending back to a shoulder surface 26, which defines the end of the housing that has been removed.

The top wall 28 of the housing has a projection 32 which extends from approximately the center of the top wall 28 flush to the rear end 34 of the housing. The bottom surface of the housing contains a cavity 36 which is formed in the bottom wall 38 of the housing and extends from approximately the center of the bottom wall rearwardly to the end surface 34 of the member. As can be readily seen, the projection 32 can be inserted into the cavity 36 so that a plurality of connector members 12 can be ganged together. Moreover, it should be noted that similar type projections and cavities could be formed on the side walls 42 of the housing, but these projections and cavities have not been illustrated for reasons of clarity.

Each of the connector members 12 are shown containing a plurality of axially aligned passageways 44 into which the contacts 15 are mounted. Each of the passageways are of generally square shape and contain a top wall 46, a bottom wall 48, and a pair of side walls 52, 54. At approximately the center of the side walls, enlarged slot portions 56 are provided for insertion of the contact into the housing. The slot portions may be chamfered at the rear end 34 as at 58 so as to facilitate insertion of the contact members. The top wall 46 extends into the housing until it reaches a rearward facing shoulder 62. The bottom wall 48 extends into the housing a slightly greater distance than the surface 46 and terminates at a rearward facing shoulder 64. The bottom wall then extends forwardly as at 66. The top wall then extends forwardly from the shoulder 62 as at 68 until it reaches a forward facing shoulder 72.

Each of the slots 56 extend into the connector housing until approximately the forward facing shoulder 72, at which point they terminate in a rearward facing shoulder 74. The U-shaped portion of the housing 18, 20, 21 terminates at a forward facing inner surface 76. In the two cavities defined by the U-shaped housing portion 18, 20, 21 a surface 78 extends between the forward facing shoulder 72 and the surface 76. Where the housing portion has been removed, the cavity walls are extended to the front surface of the housing by means of a pair of generally square shaped housing portions having a top wall 82, a bottom 84, and common central wall 86 and a pair of side walls 88, 92. The inner surface 94 of the top wall 82 terminates at the forward facing shoulder 98 formed in a plane parallel to the surface 76.

One corner of the passageways 44, shown in FIGS. 1 and 3 for illustration purposes as being the junction of bottom wall 48 and side wall 54 contains an angular portion 199 which prevents the contact 16 from being inserted in the incorrect orientation by reducing the width of a portion of the passageway 44.

The contact 16, shown in greater detail in FIG. 2, is normally stamped from a high strength copper alloy. Further, the contact is formed of a generally flat metal portion having an enlarged width mounting flange 102 which is connected at its rear to a terminal barrel 104 by means of a transition portion 106. Typically, a conductor 108 has its wires 112 bared and inserted into the terminal barrel 104. Extending forwardly from the mounting flange is a reduced width body portion 114 having a mating surface 116. The front end of the contact is

generally V-shaped, as defined by a pair of folds 118, 122. The portion 118 is connected to the body portion 114 by a slightly angular interlocking portion 124. The front tip 126 of the contact is generally a smooth, curved surface and defines the front ends of the two folds 118, 122. The rear end of the fold 122 defines a spring leaf portion 128 which is bent at a slight angle with respect to the fold 122. Each of the contacts 15 are inserted from the rear of the housing with the ends of mounting flange 102 seated in the slots 56. The fold 122 is of sufficient width that it will only seat in the side walls 52, 54 of the cavity which are not reduced by the angular portion 199.

The contact 15 is inserted in the passageway 44 until the front surface of the mounting flange 102 abuts the rearward facing shoulder 74. At this point, the end of the leaf spring abuts the forward facing shoulder 72 as shown in FIG. 5. Then, the two connector housings are mated together as shown in FIG. 6. The surfaces of the fold 118 abut each other until they are firmly positioned so that each of the surfaces of the fold abut the mating surface 116 of the body portion. In this position, as shown in FIG. 6, the angular interlocking portions 124 prevent the contacts from being separated unless a sufficient separation force is imparted to the connector housings.

To remove the contact it is only necessary to depress spring leaf portion 128 with a simple tool inserted in the front end of the housing. Then, the contact can be removed from the rear of the housing.

What is claimed is:

1. An electrical connector comprising:

an insulator member having a plurality of contact receiving passageways therethrough, each of said passageways having an enlarged slotted section extending from one end of said housing and terminating within the housing and dividing said passageway into a first portion and a second portion, the first portion being of greater width than the second portion;

a contact terminal in said passageway comprising a front end and a pair of folded sections extending rearwardly from said front end, one of said sections terminating in a leaf spring portion and the other section extending rearwardly and forming a mating surface section, an enlarged width mounting flange portion rearward of said mating surface section whose width is smaller than said enlarged slotted section but greater than either of said first and second passageway portions, the width of said first portion of said passageway being wider than the width of said folded sections, a portion of the width of said second portion being less than the width of said folded sections said mounting flange portion being positioned in said slotted section and said folded section terminating in said leaf spring portion being positioned in said first portion of said passageway.

2. An electrical connector in accordance with claim 1 wherein said enlarged slotted section is chamfered at said end of said housing for facilitating insertion of said contact terminal in said insulator member.

\* \* \* \* \*

30

35

40

45

50

55

60

65

70

75