

No. 641,008.

Patented Jan. 9, 1900.

H. F. GULLAN.
RAIL OR TRAMWAY RAIL JOINT.

(Application filed July 6, 1898.)

(No Model.)

2 Sheets—Sheet 1.

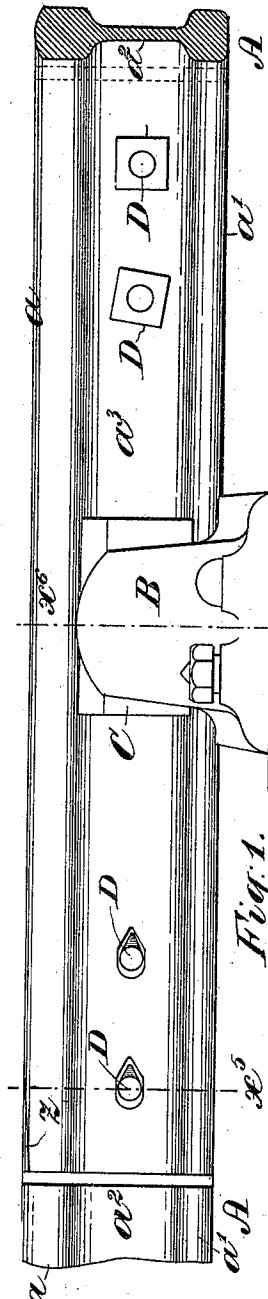

Fig. 1.

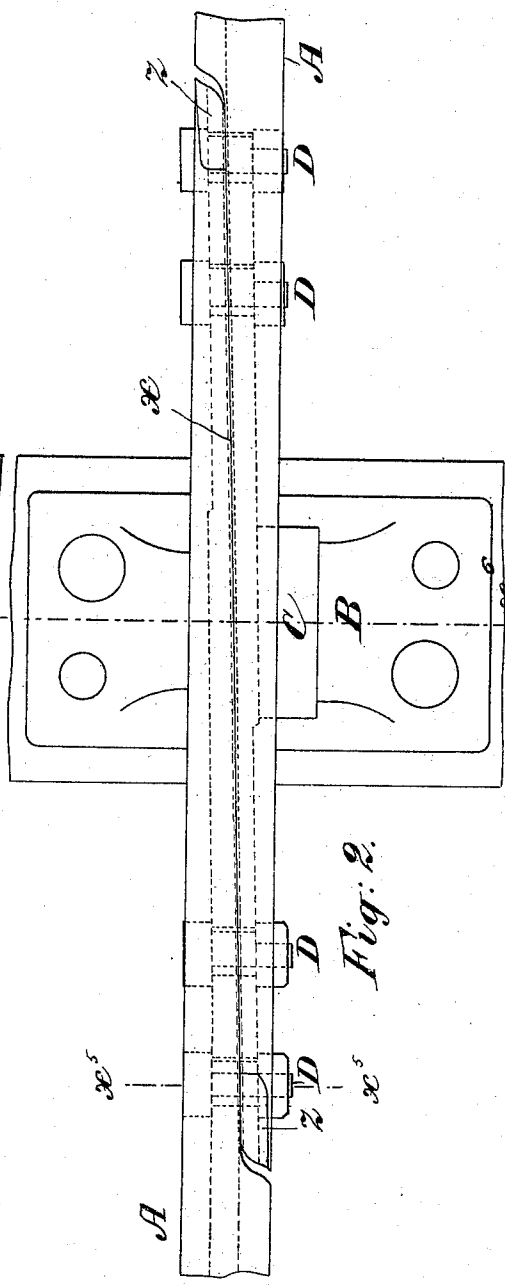

Fig. 2.

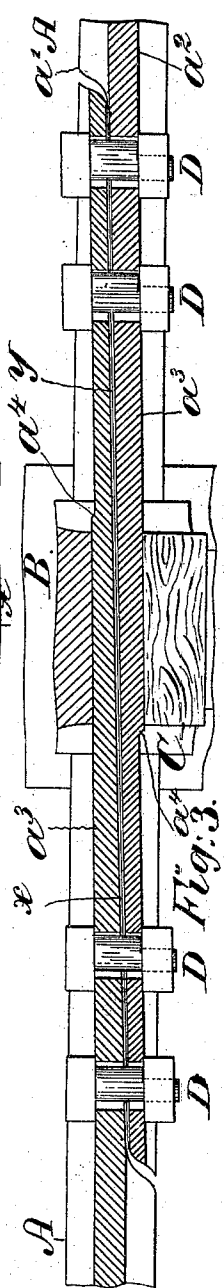

Fig. 3.

WITNESSES:

J. N. Winton
Peter S. Ross

INVENTOR

Hector F. Gullan

BY
Henry Coumes
ATTORNEY

No. 641,008.

Patented Jan. 9, 1900.

H. F. GULLAN.
RAIL OR TRAMWAY RAIL JOINT.

(Application filed July 6, 1898.)

(No Model.)

2 Sheets—Sheet 2.

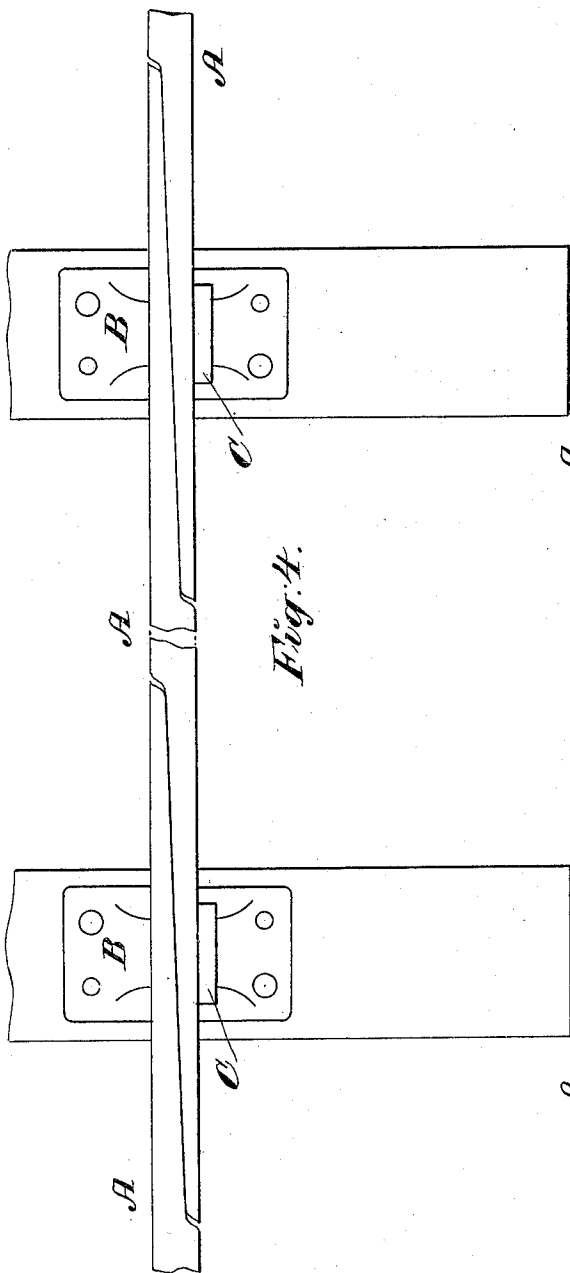

Fig. 4.

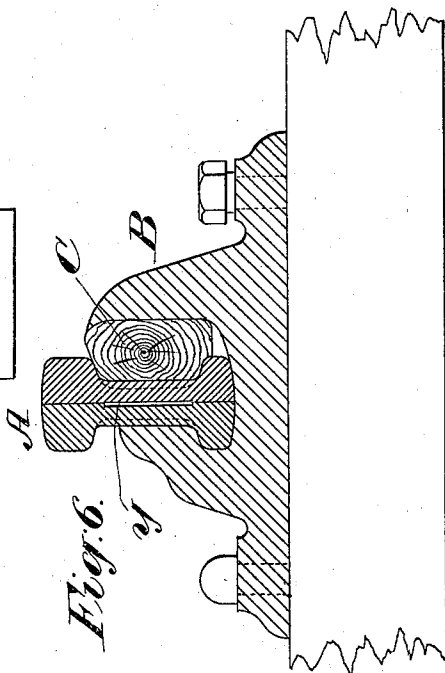

Fig. 6.

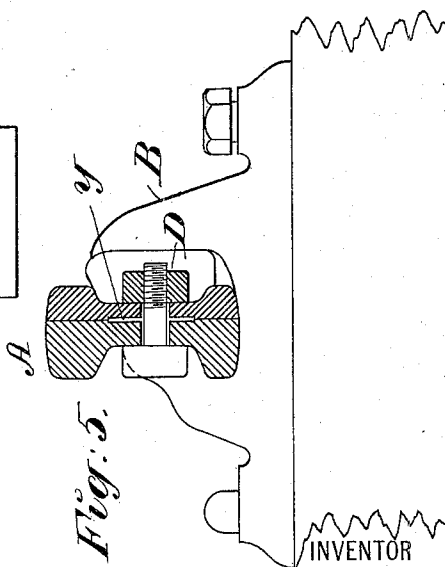

Fig. 5.

WITNESSES:

J. W. Eliman
Peter A. Ross

INVENTOR

Hector F. Gullan

BY

Henry Coumbe
ATTORNEY

UNITED STATES PATENT OFFICE.

HECTOR FREEMAN GULLAN, OF HOYLAKE, ENGLAND.

RAIL OR TRAM WAY RAIL JOINT.

SPECIFICATION forming part of Letters Patent No. 641,008, dated January 9, 1900.

Application filed July 6, 1898. Serial No. 685,233. (No model.)

To all whom it may concern:

Be it known that I, HECTOR FREEMAN GULLAN, a subject of the Queen of Great Britain, residing at Hoylake, in the county of Chester, England, have invented certain new and useful Improvements in Railway Rails and Joints, of which the following is a specification.

This invention relates to the class of scarf or lap joints in railway-rails wherein the joint is produced by cutting or forming the two rails so that the joint between the two lateral faces of the overlapping rails extends obliquely across the crown of the rail.

The object of the present invention is to employ this oblique form of scarf-joint in such a way as to insure that the rail will be as strong at the joint as at any other part without the joint having an undue thickness likely to cause the securing-bolts to be exposed to injury and without cutting away or thinning the web too much in forming the bevel for the splice. For this purpose the web toward the end of the rail is obliquely deflected laterally and is cut away or thinned only slightly in forming a bevel for the splice, this part being also formed with an offset to insure strength in the part and also for engagement with the chair or key, while the web from said offset to the extremity is reduced a little in thickness to prevent undue thickness of the joint.

The accompanying drawings illustrate an embodiment of the invention.

In the drawings, Figure 1 is a side elevation of the rails at the joint. Fig. 2 is a plan of the same. Fig. 3 is a horizontal section along the line of the bolts. Fig. 4 is a plan, on a smaller scale, showing two joints in the rails. Fig. 5 is a transverse section at line x^5 in Figs. 1 and 2. Fig. 6 is a transverse section at line x^6 in Figs. 1 and 2.

In the drawings, A A represent two I-rails constructed at their adjacent ends to form a joint with a lap-splice, they being supported in a chair B at the splice. C is the key between the chair and the rail. Each rail A has a head a , a foot a' , and a web a^2 , and the ends of the rail are so formed as to adapt them for forming the splice-joint. In Fig. 4 both ends of the rail are shown, the middle portion being mainly broken away for lack of room.

It will be noted, Figs. 2 and 3, that when

the rail is seen in plan the vertical plane of the joint x extends obliquely across the rail, that the securing-bolts D pass through slotted holes in the webs of the overlapping rails, that the portions a^3 of the webs that overlap at the joint are deflected laterally and obliquely, so that they may not be cut away or thinned too much in forming the bevel for the splice, that the outer faces of the two overlapping webs a^3 at the chair B or middle portion of the joint are parallel, that there is an offset a^4 in the outer face of each web, from which offset to the extremity of the rail the web is thinner than in the main part, and that at every point along the length of the lap-splice the thickness of the two lapped webs is greater than the thickness of the normal web a^2 . This imparts strength to the rail at the splice and is due to the lateral deflection of the lapped parts of the webs of the rails.

To form the ends of the rails as shown, they may be passed through properly-shaped roller-dies while hot. Preferably there will be formed a slight trough-like hollow or channel in the applied faces of the webs a^3 , as seen at y , Figs. 5 and 6, so as to permit the heads and bases of the rails to come together snugly and to reduce the friction between the surfaces in contact when they move on each other in expanding and contracting, and the crowns of the rails at their extreme ends may be slightly cut away or rounded off, as seen at z , to guard against this thinned extremity projecting upward above the level of the adjacent rail.

I prefer not to employ fish-plates at the joint; but it is obvious that they may be used, if desired. Preferably the splice will be supported in a chair; but it may be situated between chairs.

My construction obviously permits the use of a relatively thin web.

Having thus described my invention, I claim—

1. In a railway-rail adapted to form a lapped or scarf rail-joint between adjacent rails, the combination of a head and base having their flanges at the end portion cut away obliquely at one side, a vertical web having its end portion deflected laterally to the other side and an offset a^4 on the outer face of the web to in-

sure strength and for engagement with the chair or key, the web from said offset to the extremity being reduced a little in thickness substantially as and for the purpose set forth.

5 2. A railway-rail adapted to form a scarf rail-joint between adjacent rails, said rail having a head, base and vertical web, the head and base having their flanges at the end portion cut away obliquely at one side, and
10 the web having its end portion also cut away obliquely flush with said head and base, said web being also deflected laterally away from the joint and having formed in its inner or
15 jointing face a trough-like channel or hollow y , which forms a reduction in the thickness of the web, substantially as and for the purposes set forth.

3. In a railway-rail adapted to form a lapped or scarf rail-joint between adjacent rails, the
20 combination of a head having its crown at the extremity z slightly rounded or cut away below the normal level and its flange at the end portion cut away obliquely at one side, a base having its flange similarly cut away
25 obliquely to one side, a vertical web having

its end portion deflected laterally to the other side, an offset a^4 on the outer face of the web to insure strength and for engagement with the chair or key, the web from said offset to the extremity being reduced a little in thick- 30
ness, and a trough-like hollow or channel y in the inner or jointing face of the web, substantially as hereinbefore described.

4. A railway-rail having an I cross-section and having at its end portion which is destined 35
to form the scarf-joint between the rails, constructed as follows, namely: the flanges of the head and base extend straight to the end of the rail at the outside and at the front are cut away obliquely at the inside, and the web 40
is deflected outwardly at the joint and also cut away obliquely on the inside, substantially as set forth.

In witness whereof I have hereunto signed my name, this 22d day of June, 1898, 45
in the presence of two subscribing witnesses.

HECTOR FREEMAN GULLAN:

Witnesses:

G. C. DYMOND,
W. H. BEESTON.