



(86) Date de dépôt PCT/PCT Filing Date: 2005/03/31
 (87) Date publication PCT/PCT Publication Date: 2005/10/13
 (45) Date de délivrance/Issue Date: 2014/07/08
 (85) Entrée phase nationale/National Entry: 2006/08/30
 (86) N° demande PCT/PCT Application No.: EP 2005/003398
 (87) N° publication PCT/PCT Publication No.: 2005/095660
 (30) Priorité/Priority: 2004/03/31 (DE10 2004 016 482.7)

(51) Cl.Int./Int.Cl. *C22C 21/00* (2006.01),
C22F 1/04 (2006.01)
 (72) Inventeurs/Inventors:
SICKING, RAIMUND, DE;
WAGNER, PASCAL, DE;
MROTZEK, MANFRED, DE;
HUSSE, THOMAS, DE;
BERMING, GERHARD, DE
 (73) Propriétaire/Owner:
HYDRO ALUMINIUM DEUTSCHLAND GMBH, DE
 (74) Agent: SMART & BIGGAR

(54) Titre : ALLIAGE D'ALUMINIUM THERMORESISTANT DESTINE A UN ECHANGEUR DE CHALEUR
 (54) Title: HEAT-RESISTANT ALUMINIUM ALLOY FOR HEAT EXCHANGERS

(57) **Abrégé/Abstract:**

The invention relates to a heat-resistant aluminium alloy for heat exchangers, a method for producing an aluminium strip or sheet for heat exchangers, and a corresponding aluminium strip or sheet. The aim of the invention is to provide an aluminium alloy and an aluminium strip or sheet which has a good recycling capacity, a Solidus temperature of at least 620 °C, and an improved heat-resistance after welding. To this end, the inventive aluminium alloy comprises the following parts of alloy constituents in wt. %: 0.3 % ≤ Si ≤ 1 %, Fe ≤ 0.5 %, 0.3 % ≤ Cu ≤ 0.7 %, 1.1 % ≤ Mn ≤ 1.8 %, 0.15 % ≤ Mg ≤ 0.6 %, 0.01 % ≤ Cr ≤ 0.3 %, Zn ≤ 0.10 %, Ti ≤ 0.3 %, unavoidable impurities separately representing a maximum of 0.1 %, and together a maximum of 0.15 %, the remainder being aluminium.



(12) NACH DEM VERTRAG ÜBER DIE INTERNATIONALE ZUSAMMENARBEIT AUF DEM GEBIET DES
PATENTWESENS (PCT) VERÖFFENTLICHTE INTERNATIONALE ANMELDUNG(19) Weltorganisation für geistiges Eigentum
Internationales Büro(43) Internationales Veröffentlichungsdatum
13. Oktober 2005 (13.10.2005)

PCT

(10) Internationale Veröffentlichungsnummer
WO 2005/095660 A1

- (51) Internationale Patentklassifikation⁷: C22C 21/00, C22F 1/04
- (74) Anwalt: COHAUSZ & FLORACK; Bleichstrasse 14, 40211 Düsseldorf (DE).
- (21) Internationales Aktenzeichen: PCT/EP2005/003398
- (81) Bestimmungsstaaten (soweit nicht anders angegeben, für jede verfügbare nationale Schutzrechtsart): AE, AG, AL, AM, AT, AU, AZ, BA, BB, BG, BR, BW, BY, BZ, CA, CH, CN, CO, CR, CU, CZ, DE, DK, DM, DZ, EC, EE, EG, ES, FI, GB, GD, GE, GH, GM, HR, HU, ID, IL, IN, IS, JP, KE, KG, KP, KR, KZ, LC, LK, LR, LS, LT, LU, LV, MA, MD, MG, MK, MN, MW, MX, MZ, NA, NI, NO, NZ, OM, PG, PH, PL, PT, RO, RU, SC, SD, SE, SG, SK, SL, SM, SY, TJ, TM, TN, TR, TT, TZ, UA, UG, US, UZ, VC, VN, YU, ZA, ZM, ZW.
- (22) Internationales Anmeldedatum:
31. März 2005 (31.03.2005)
- (25) Einreichungssprache: Deutsch
- (26) Veröffentlichungssprache: Deutsch
- (30) Angaben zur Priorität:
10 2004 016 482.7 31. März 2004 (31.03.2004) DE
- (84) Bestimmungsstaaten (soweit nicht anders angegeben, für jede verfügbare regionale Schutzrechtsart): ARIPO (BW, GH, GM, KE, LS, MW, MZ, NA, SD, SL, SZ, TZ, UG, ZM, ZW), eurasisches (AM, AZ, BY, KG, KZ, MD, RU, TJ, TM), europäisches (AT, BE, BG, CH, CY, CZ, DE, DK, EE, ES, FI, FR, GB, GR, HU, IE, IS, IT, LT, LU, MC, NL, PL, PT, RO, SE, SI, SK, TR), OAPI (BF, BJ, CF, CG, CI, CM, GA, GN, GQ, GW, ML, MR, NE, SN, TD, TG).
- (71) Anmelder (für alle Bestimmungsstaaten mit Ausnahme von US): HYDRO ALUMINIUM DEUTSCHLAND GMBH [DE/DE]; Ettore-Bugatti-Str. 6-14, 51149 Köln (DE).
- (72) Erfinder; und
- (75) Erfinder/Anmelder (nur für US): SICKING, Raimund [DE/DE]; Bennauerstrasse 53, 53115 Bonn (DE). WAGNER, Pascal [LU/DE]; Hiltrudstrasse 11, 50999 Köln (DE). MROTZEK, Manfred [DE/DE]; Lupinenkamp 4, 21614 Buxtehude (DE). HUSSE, Thomas [DE/DE]; Cusanushof 19a, 41812 Erkelenz (DE). BERMING, Gerhard [DE/DE]; Haferkamp 11, 21640 Horneburg (DE).
- Veröffentlicht:
— mit internationalem Recherchenbericht
- Zur Erklärung der Zweibuchstaben-Codes und der anderen Abkürzungen wird auf die Erklärungen ("Guidance Notes on Codes and Abbreviations") am Anfang jeder regulären Ausgabe der PCT-Gazette verwiesen.

(54) Title: HEAT-RESISTANT ALUMINIUM ALLOY FOR HEAT EXCHANGERS

(54) Bezeichnung: WARMFESTE ALUMINIUMLEGIERUNG FÜR WÄRMETAUSCHER

(57) Abstract: The invention relates to a heat-resistant aluminium alloy for heat exchangers, a method for producing an aluminium strip or sheet for heat exchangers, and a corresponding aluminium strip or sheet. The aim of the invention is to provide an aluminium alloy and an aluminium strip or sheet which has a good recycling capacity, a Solidus temperature of at least 620 °C, and an improved heat-resistance after welding. To this end, the inventive aluminium alloy comprises the following parts of alloy constituents in wt. %: 0.3 % ≤ Si ≤ 1 %, Fe ≤ 0.5 %, 0.3 % ≤ Cu ≤ 0.7 %, 1.1 % ≤ Mn ≤ 1.8 %, 0.15 % ≤ Mg ≤ 0.6 %, 0.01 % ≤ Cr ≤ 0.3 %, Zn ≤ 0.10 %, Ti ≤ 0.3 %, unavoidable impurities separately representing a maximum of 0.1 %, and together a maximum of 0.15 %, the remainder being aluminium.

(57) Zusammenfassung: Die Erfindung betrifft eine warmfeste Aluminiumlegierung für Wärmetauscher, ein Verfahren zur Herstellung eines Aluminiumbandes oder -bleches für Wärmetauscher sowie ein entsprechendes Aluminiumband oder -blech. Die Aufgabe, eine Aluminiumlegierung und ein Aluminiumband oder -blech zur Verfügung zu stellen, welche bzw. welches bei guter Recyclingfähigkeit eine Solidustemperatur von mindestens 620 °C und gleichzeitig eine verbesserte Warmfestigkeit nach dem Lötten aufweist, wird für eine Aluminiumlegierung dadurch gelöst, dass die Aluminiumlegierung die folgenden Anteile an Legierungsbestandteilen in Gew.-% aufweist: 0,3 % ≤ Si ≤ 1 %, Fe ≤ 0,5 %, 0,3 % ≤ Cu ≤ 0,7 %, 1,1 % ≤ Mn ≤ 1,8 %, 0,15 % ≤ Mg ≤ 0,6 %, 0,01 % ≤ Cr ≤ 0,3 %, Zn ≤ 0,10 %, Ti ≤ 0,3 %, unvermeidbare Verunreinigungen einzeln max. 0,1 %, in Summe max. 0,15 % und als Rest Aluminium.



WO 2005/095660 A1

HEAT RESISTANT ALUMINIUM ALLOY FOR HEAT EXCHANGERS

The invention relates to a heat resistant aluminium alloy for heat exchangers, a method for producing an aluminium strip or aluminium sheet for heat exchangers, and a corresponding aluminium strip or aluminium sheet.

In the automotive sector there is an increasing tendency to use heat exchangers made of aluminium or aluminium alloys. The use of aluminium instead of the previously customary non-ferrous metal heat exchangers has hereby almost halved the weight of the heat exchangers for comparable size and performance. The heat exchangers made of aluminium or of an aluminium alloy are nowadays used in the motor vehicle mostly for cooling the cooling water or the oil, as charge air cooler and in air conditioners. Heat exchangers for motor vehicles are usually produced from aluminium strips or aluminium sheets, by joining together the individual prefabricated components of the heat exchanger, such as for example fins, tubes and distributors, by way of brazing. In practical applications, the loads acting on components produced in this way and installed in motor vehicles, are considerable due to shock-like juddering, long-duration vibrations, corrosion, high operating pressures, high operating temperatures and temperature changes. In spite of the considerable loads and increasing operating pressures of the heat exchangers in the motor vehicle, there is still a prevailing trend toward weight savings

in the motor vehicle and, with it, toward a further reduction of the wall thickness of the heat exchangers. Moreover, the stricter legislation in the EU and in the USA with respect to the emission standards leads to additionally increased operating temperatures, for example of charge air coolers, so that the demands on the heat resistance of the aluminium alloy subsequent to brazing continue to rise. With the aluminium alloys for heat exchangers used so far, it was only possible to reach values with respect to the strength determining yield strength $R_{p0.2}$ of less than 65 MPa, and of markedly less than 65 MPa at high temperatures of about 250° C, subsequent to brazing. In view of further wall reductions, these values for the yield strength are no longer adequate to meet future demands on heat exchangers. A known means to increase the heat resistance of aluminium alloys is the alloying into the aluminium alloy of, for example, the elements Ni, Zr or rare earths in greater or lesser doses. These alloy components are however not usually contained in aluminium alloys and present damaging effects in application cases other than brazed heat exchangers. In this respect, the alloying of the abovementioned alloy components represents a great problem in regard to the recyclability of the aluminium alloy, also in view of the EU end-of-life vehicle directive. The methods most frequently used for the production of heat exchangers are, on the one hand, flux-free vacuum brazing and, on the other hand, brazing in a protective gas using non-corrosive fluxes. The age hardening aluminium alloys used so far for vacuum brazing, for example the aluminium alloy AA6063 (AlMgO, 7Si), AA6061 (AlMg1SiCu) or AA6951 (AlMgO, 6SiCu), have relatively high magnesium contents and are generally

brazed with solders having a high Mg content, such as for example AA4004, in order to, on the one hand, prevent oxidation by gettering of the molten aluminium solder on the components to be brazed during the vacuum brazing process, thus ensuring a faultless brazed joint without flux, and, on the other hand, achieve high strength values of the brazed heat exchangers for natural ageing subsequent to brazing. In the case of vacuum brazing, it is a disadvantage that the preservation of the vacuum and the purity demands on the components to be brazed are cost-intensive. In view of this, the alternative brazing in a protective gas is less cost-intensive because the brazing takes place in a protective atmosphere comprising an inert protective gas, for example nitrogen.

Furthermore, brazing in a protective gas enables up to 20% shorter brazing cycles, but it is not possible to use the aluminium alloy with high magnesium contents known from vacuum brazing because the magnesium reacts with the non-corrosive flux during the brazing. The workability can be extended to higher Mg contents by applying expensive caesium containing fluxes. Brazing in a protective gas, also called CAB brazing, is the most important process for producing heat exchangers for the automotive industry. In addition, salt bath brazing is also available, where the components are preheated and subsequently immersed in a salt bath. The salt bath is both flux and transport medium for the heat. The liquid salt reacts with the oxide skin and enables the wetting reaction of the solder, which is protected by the flux. After the holding time at brazing temperature, the heat exchangers are driven out of the salt bath, whereby it must be ensured that the liquid salt is drained. Because the fluxes used for salt bath brazing are normally

hygroscopic and contain chlorides, all heat exchangers must be cleaned in a multiple step process subsequent to the salt bath brazing to avoid corrosion problems. In order to prevent a fusion of the core aluminium alloy of the heat exchanger elements to be brazed in one of the three described brazing methods, the aluminium alloy should furthermore have a solidus temperature of at least 620° C.

In view of the above, it is an object of the present invention to provide an aluminium alloy and an aluminium strip or aluminium sheet, which has good recyclability, a solidus temperature of at least 620° C and also an improved heat resistance subsequent to brazing. It is a further object of the present invention to provide a method for producing a corresponding aluminium strip or aluminium sheet.

According to a first teaching of the present invention, the object described above is solved by an aluminium strip or aluminium sheet comprised of an aluminium alloy, wherein the aluminium alloy comprises the following proportions of alloy components in weight percent:

$$\begin{aligned} 0.3 \% &\leq \text{Si} \leq 1 \% , \\ &\text{Fe} \leq 0.5 \% , \\ 0.3 \% &\leq \text{Cu} \leq 0.7 \% , \\ 1.1 \% &\leq \text{Mn} \leq 1.8 \% , \\ 0.15 \% &\leq \text{Mg} \leq 0.6 \% , \\ 0.01 \% &\leq \text{Cr} \leq 0.3 \% , \\ &\text{Zn} \leq 0.10 \% , \\ &\text{Ti} \leq 0.3 \% , \end{aligned}$$

unavoidable impurities separately representing a maximum of 0.1 %, together a maximum of 0.15 %, and the remainder being aluminium, wherein the yield strength $R_{p0.2}$ of the aluminium strip or aluminium sheet is greater than 65 MPa at room temperature and at a temperature of 250 °C.

The aluminium alloy according to the invention does not only feature a solidus temperature of more than 620° C, but it also has a particularly high heat resistance subsequent to brazing. The aluminium alloy according to the invention enables the production of heat exchanger elements, for example tubes, the yield strength $R_{p0.2}$ of which is greater than 65 MPa both at room temperature and at a test temperature of 250° C, subsequent to brazing of the heat exchangers. In comparison with the conventional aluminium alloys, in particular a AA3005 alloy, heat exchanger elements produced from the aluminium alloy according to the invention thus have a greater than 20% higher heat resistance, in particular also at temperatures of up to 265° C. The attainable heat resistance is ascribed to achieving a high secondary phase density by combining an increased Si, Mn and Cr content with the aluminium alloy according to the invention. In addition, the aluminium alloy according to the invention has a greater positive corrosion potential of -750 mV. Elements such as tubes, tube plates, side parts or disks of a heat exchanger produced from the aluminium alloy according to the invention enable the corrosion design of the heat exchanger to be laid out in such a way that the described elements of the heat exchanger have a high corrosion resistance. Moreover, the aluminium alloy according to the invention presents merely a reduced age hardening characteristic, so that the aluminium strips or aluminium sheets comprising the aluminium alloy according to the invention are not

subjected to storage time limitations prior to processing or forming prior to brazing.

Subsequent to brazing of components of a heat exchanger made from the aluminium alloy according to the invention, it was further surprisingly found that a good corrosion resistance is achieved in spite of the elevated Cu content.

The proportion in the alloy of the alloy component Si of 0.3 to 1.0 weight percent leads, in combination with the alloy proportions of the remaining alloy components, to the strength of the aluminium alloy being sufficiently high subsequent to brazing and, at the same time, to the melting point not decreasing. Upon leaving this range of the Si content, when falling below the lower limit of the Si content, the strength of the aluminium alloy becomes too low subsequent to brazing and, when exceeding the upper limit of the Si content, the solidus temperature is reduced to a value below 620° C. The limitation of the Fe content of the aluminium alloy according to the invention to a maximum of 0.5 weight percent improves, in conjunction with the Cu content according to the invention, the corrosion resistance of the aluminium alloy subsequent to brazing. During brazing, the layers in the proximity of the surface of the core material made of the aluminium alloy according to the invention are depleted from copper, so that a protecting potential gradient to the nobler core material with greater Cu content is generated. This behaviour of the aluminium alloy during brazing is promoted by the low iron content. The heat resistance of the aluminium alloy according to the invention drops noticeably at a Cu content of less

than 0.3 weight percent; upon exceeding the upper limit of the Cu content, the aluminium alloy has, however, a tendency to heat cracking during casting. Furthermore, corrosion and brazing problems arise for greater Cu contents as a result of the layers in the proximity of the surface of the core material having a relatively high Cu content, despite depletion. On the one hand, the Mn content of the aluminium alloy according to the invention determines the size of the segregations. On the other hand, the Mn content has also an influence on the heat resistance. If the amount of manganese in the aluminium alloy according to the invention falls below the lower limit of 1.1 weight percent, the heat resistance of the aluminium alloy is reduced. An increase of the manganese content above the upper limit of 1.8 weight percent leads, in contrast, to coarse segregations in the structure, which have a largely negative influence on the formability of the aluminium alloy. The strength of the aluminium alloy subsequent to brazing is additionally influenced by the Mg content. A reduction of the Mg content below 0.15 % leads to poor strength of the aluminium alloy. The upper limit of the Mg content of 0.6 weight percent ensures that the aluminium alloy according to the invention is brazeable with all three conventional brazing methods, the vacuum, CAB and salt bath methods. The inventive Cr content of the aluminium alloy of at least 0.01 weight percent ensures, on the one hand, that the aluminium alloy according to the invention has sufficient heat resistance. On the other hand, the formability of the aluminium alloy according to the invention is ensured by limiting the Cr content to a maximum of 0.3 weight percent, since coarse segregations in the crystal structure of the aluminium alloy are found

in the case of said Cr content being exceeded. In order for the aluminium alloy according to the invention to be ideally suited for producing tube strip, tube plate strip, side part strip and disk strip, the Zn content of the aluminium alloy is limited to a maximum of 0.1 weight percent. A higher Zn content leads to a reduction of the corrosion potential of the aluminium alloy, so that the aluminium alloy is, for example, too ignoble relative to Zn-free fins. Lastly, the inventive Ti content of no more than 0.3 weight percent ensures that no coarse segregations are formed in the aluminium alloy, which would, in turn, have a negative influence on the formability of the aluminium alloy.

If the aluminium alloy according to the invention has, according to another further developed embodiment, the following proportions of alloy components in weight percent:

$$0.15 \% \leq \text{Mg} \leq 0.3 \%$$

$$\text{Zn} \leq 0.05 \%$$

$$0.01 \% \leq \text{Ti} \leq 0.3 \%,$$

the aluminium alloy according to the invention can be processed according to the CAB brazing method without expensive caesium containing fluxes, with the risk of cracks during solidification of the rolling ingot simultaneously being reduced by the Ti content and the corrosion potential being increased by the reduced Zn content.

A very good compromise of maximum strength subsequent to brazing and simultaneously high solidus temperature is

achieved, according to a further embodiment of the aluminium alloy according to the invention, by the aluminium alloy comprising the following proportions of the alloy components Si, Fe and Mn in weight percent:

$$\begin{aligned} 0.5 \% \leq \text{Si} \leq 0.8 \%, \\ \text{Fe} \leq 0.35 \%, \\ 1.1 \% \leq \text{Mn} \leq 1.5 \%. \end{aligned}$$

According to a second teaching, the invention also provides a method for producing an aluminium strip or aluminium sheet for heat exchangers from a heat resistant aluminium alloy, wherein the aluminium alloy comprises the following proportions of alloy components in weight percent:

$$\begin{aligned} 0.3 \% \leq \text{Si} \leq 1 \%, \\ \text{Fe} \leq 0.5 \%, \\ 0.3 \% \leq \text{Cu} \leq 0.7 \%, \\ 1.1 \% \leq \text{Mn} \leq 1.8 \%, \\ 0.15 \% \leq \text{Mg} \leq 0.6 \%, \\ 0.01 \% \leq \text{Cr} \leq 0.3 \%, \\ \text{Zn} \leq 0.10 \%, \\ \text{Ti} \leq 0.3 \%, \end{aligned}$$

unavoidable impurities separately representing a maximum of 0.1 %, together a maximum of 0.15 %, and the remainder being aluminium, wherein a rolling ingot is cast in a continuous casting process, the rolling ingot is preheated at 400 to 500°C prior to hot rolling, the rolling ingot is rolled to a hot strip, with the hot strip temperature being 250 to 380 °C and the hot strip thickness being 3 to 10 mm at the end of the hot rolling and the hot strip is cold rolled to final thickness. An aluminium strip having a high secondary phase density can be produced by combining the described method features for producing an aluminium strip, in conjunction with the aluminium alloy according to the invention. As a

9a

result of the high secondary phase density, an aluminium strip or aluminium sheet according to the invention has a high thermal resistance at room temperature and at a temperature of 250° C. The yield strength $R_{p0.2}$ of the aluminium strip is greater than 65 MPa at the above mentioned temperatures.

If the aluminium strip or aluminium sheet is to be a side part strip, disk strip or tube plate strip, then,

according to another further developed embodiment of the invention, the ingot can be homogenized prior to preheating. As a result of the deformations which are necessary for producing a tube plate, side part or a disk of a heat exchanger, the aluminium strip should have a maximum formability prior to the processing to one of the last mentioned elements of a heat exchanger. This is ensured by the homogenization prior to the preheating of the rolling ingot. Unless the aluminium strip according to the invention does not have to be subjected to severe deformations prior to brazing, such as, for example, for the production of tubes, a homogenization step prior to the preheating can be dispensed with. Although the yield strength $R_{p0.2}$ of the aluminium strip is reduced by the homogenization prior to the preheating, the yield strength $R_{p0.2}$ is still greater than 50 MPa, in particular also for test temperatures of 250° C, so that yield strengths are achieved, which are far greater than those of the standard alloy AA 3003.

The formability of the aluminium strip can be further improved by intermediate annealing of the hot strip at a temperature of 300 to 450° C. Alternatively or cumulative thereto, it is possible to subject the aluminium strip to intermediate annealing at a temperature of 300 to 450° C during cold rolling, prior to achieving the final thickness. By means of the intermediate annealing steps, solidifications, which have been created in the aluminium strip as a result of deformations, are removed again to a large extent. The process steps mentioned above ensure a maximum formability during cold rolling of the aluminium strip or aluminium sheet.

The final state of the aluminium strip is obtained, according to a further developed embodiment of the method according to the invention, by carrying out, subsequent to the cold rolling, a phase annealing step to the final state at a temperature of 250 to 400° C. If the aluminium strip is used for the production of tube plates, side parts or disks of a heat exchanger, a soft annealing step takes place subsequent to the cold rolling. If tubes are produced from the aluminium strip, which does not require strong deformations, the aluminium strip is merely re-annealed subsequent to the cold rolling.

According to another further developed embodiment of the method according to the invention, subsequent to the preheating, the rolling ingot is provided on one or two sides with plates made of another alloy. In this way, the properties of the plate-clad side of the core ingot can be adjusted almost independently from the aluminium core alloy. The process reliability during brazing of the heat exchanger elements can be increased, for example, by cladding using an aluminium solder. In addition, other plates comprising non-solder alloys can also be attached to the aluminium core ingot, for example corrosion protective claddings. When using a plate of aluminium solder, the aluminium solder layer is cold-welded to the core ingot during hot rolling, so that the aluminium strip comprises a uniform cladding layer. This leads to particularly homogenous and uniform brazed joints between the individual elements of the heat exchanger during brazing. In the case of one-sided cladding with an aluminium solder, it is furthermore possible to clad or to coat the other side with another aluminium alloy, for example with an aluminium alloy serving as corrosion

protection. Aluminium tubes for heat exchangers are clad on one or two sides, depending on requirements. The aluminium strip for side parts are, however, usually clad on one side. Tube plates and disks of a heat exchanger are, in contrast, used mostly with double-sided cladding.

It is also conceivable to use other alternative solder application methods in conjunction with the aluminium strip according to the invention.

According to a further embodiment of the method according to the invention, the method according to the invention for producing an aluminium strip can be improved by using as aluminium solder an aluminium alloy comprising 6 to 13 % Si, in particular an AlSi7.5 alloy or AlSi10 alloy. As a result of the high Si content of the solder, the silicon diffuses out of the solder into the core of the aluminium strip, where it leads to the formation of a segregation seam of AlMnSi phases, which, compared to the core alloy, have a negative corrosion potential. In the case of a corrosion attack on an aluminium strip produced in accordance with the method according to the invention, the corrosion therefore develops along the length of the aluminium strip and along the segregation seam, respectively. The core of the aluminium strip remains corrosion free and a perforation, for example of a tube produced from a corresponding aluminium alloy, can thus be prevented. The described aluminium alloy comprising 6 to 13 weight percent Si, which are used as aluminium solder, can also contain further elements besides Si, for example 0.5 to 2 weight percent Zn.

By cold rolling the aluminium strip to a final thickness of 0.1 to 2 mm during cold rolling, heat exchangers having reduced wall thickness can be produced, which nevertheless comply with the stricter future operating requirements.

Moreover, according to a third teaching of the present invention, the object described above is solved by an aluminium strip or aluminium sheet made of an aluminium alloy according to the invention, wherein the aluminium strip or aluminium sheet is produced in accordance with the method according to the invention.

The aluminium strip or aluminium sheet is preferably a tube strip, a tube plate strip, a side part strip or a disk for producing a heat exchanger. With the tube strip, tube plate strip, side part strip or disk strip according to the invention, corresponding elements of the heat exchanger, tubes, tube plates, side parts or diskis can be produced, which, despite the reduced wall thickness, comply with all the remaining requirements, in particular with regards to the formability prior to brazing and the yield strength at room and operating temperature.

According to an advantageous embodiment of the aluminium strip according to the invention, the weight of the heat exchangers can be reduced by the tube strip having a final thickness of 0.15 to 0.6 mm, preferably 0.15 to 0.4 mm, the tube plate strip having a final thickness of 0.8 to 2.5 mm, preferably 0.8 to 1.5 mm, the side part strip having a final thickness of 0.8 to 1.8 mm, preferably 0.8 to 1.2 mm or the disk strip having a final thickness of 0.3 to 1.0 mm, preferably 0.3 to 0.5 mm.

There are now a multiplicity of options for further developing and configuring the aluminium alloy according to the invention, the method according to the invention for producing an aluminium strip for heat exchangers, and the aluminium strip.

Reference is hereto made to the description of exemplary embodiments in conjunction with the drawings, in which

Fig. 1 is a schematic representation of a first exemplary embodiment of the method according to the invention for producing an aluminium strip and

Fig. 2 is a perspective view of a heat exchanger for motor vehicles.

Fig. 1 shows schematically a first exemplary embodiment of a method according to the invention for producing an aluminium strip or aluminium sheet for heat exchangers according to the second teaching of the present invention. In a first step, Fig. 1 shows the ingot casting 1. Subsequent to the alloying of the liquid metal, both the aluminium alloy for the core and the alloy for cladding, for example an aluminium solder, are cast as ingots. The cladding ingot is usually preheated, hot rolled to the desired thickness and divided longitudinally to produce a plate. The plate can, however, also be produced by using alternative methods, for example by separation from a rolling ingot.

The core ingot made of an aluminium alloy according to the invention can optionally be homogenized from the rolling product to be produced prior to preheating. If, for example, a tube strip for heat exchangers is produced using the method according to the invention, a homogenization step

prior to the hot rolling may, however, also be dispensed with, since the tube strip is not subjected to large deformations prior to production of a tube for heat exchangers.

The plates required for cladding are laid on one or both sides of the core ingot. The resulting stack comprising a core ingot, consisting of an aluminium alloy according to the invention, which is provided with plates on one or two sides, is preheated at 400 to 500° C prior to hot rolling as shown at reference numeral 2. The stack is then hot rolled in a reversing stand 3 or, alternatively, on a tandem stand 3a to a hot strip thickness of 3 to 10 mm. The hot strip temperature during hot rolling is of 250 to 380° C.

Subsequent to the hot rolling, the strip is cold rolled on a cold roller 4. According to the invention, the strip can be intermediately annealed at a temperature of 300° C to 450° C subsequent to the hot rolling, for example in order to achieve the forming properties. This applies also for the cold rolling, wherein the intermediate annealing can also take place at a temperature of 300° C to 450° C prior to reaching the final thickness. The finished cold rolled aluminium strip or aluminium sheet according to the invention can be subjected to a phase annealing step in a batch furnace 5, depending on the properties required. A phase annealing step may, however, also take place in a continuous furnace.

Fig. 2 shows a heat exchanger 8 of a tube/fin design in a perspective view. It can be seen that the heat exchanger

is comprised of a tube 9, a tube plate 10, side parts 11 and fins 12. The side parts 11 and the tube plate 10 are subjected to severe deformations prior to brazing, so that the aluminium strip intended for the side parts 11 and the tube plate 10 should have correspondingly good forming properties. The tubes 10 of the heat exchanger are generally produced by longitudinal seam welding. The thickness of the tube strip processed in this way is of between 0.15 mm and 0.6 mm, preferably 0.15 to 0.4 mm, with the tube strip being solder clad externally or on both sides, depending on the construction type of the heat exchanger. The requirements on the formability of a tube strip are rather low, since it is only subjected to simple forming prior to brazing. Subsequent to brazing, both the resistance and the heat resistance of the tube are very important, since operating media passed through the tubes are subjected to high operating pressures and the tube is partly subjected to high operating temperatures. An aluminium strip according to the invention for the tube plate 10 typically has a thickness of 0.8 to 2.5 mm, preferably 0.8 to 1.5 mm, and is preferably produced and processed in the state "soft". For this, subsequent to the cold rolling, the aluminium alloy according to the invention is annealed to the final state "soft". The requirements on the formability prior to brazing are high for the tube plate strip, since forming is carried out at a high strain rate, which is used for the sealing and fastening of, for example, a water box, a collector, an air connection or similar components. The tube plate strip is normally clad on one side, it can, however, also be clad on both sides. For reasons of corrosion protection, the tube plate 10 and also the tube 9 can comprise another aluminium alloy as

protective cladding, in order to be even more corrosion resistant. The side parts 11 are produced and processed, preferably in the state "soft", from an aluminium strip comprising an aluminium alloy according to the invention having a wall thickness of 0.8 to 1.8 mm, preferably 0.8 to 1.2 mm. As for the tube plate 10, the requirements on the formability of the side parts are high. This also applies to a disk of a heat exchanger not shown on Fig. 2, which is used for heat exchangers of the disk-fin type or heat exchangers of the stacked disk type.

Apart from high strength values of the aluminium alloy, a high corrosion resistance is especially required. With an aluminium alloy according to the invention, the reduced iron content and increased copper content make an "in-situ formation" of a cathodic corrosion protection possible during the brazing process. Firstly, copper diffuses during brazing from the regions of the core material in the proximity of the cladding layer to the aluminium solder layer, so that a protective potential gradient to the nobler core material is generated. In addition, silicon diffuses from the aluminium solder having a high silicon content into the core material of the aluminium strip according to the invention, where it leads to the formation of a segregation seam comprised of AlMnSi phases. However, compared with the core alloy, the AlMnSi phases have a greater negative corrosion potential. In the case of a corrosion attack on a brazed tube which is produced from an aluminium strip according to the invention, as a result of the segregation seam, the corrosion will initially continue to develop along the length of the tube and not penetrate the core

material, thus being able to prevent a perforation of the tube.

Finally, according to a second exemplary embodiment of the present invention, an aluminium strip for the production of tubes for heat exchangers was produced according to the method according to the invention and its heat resistance measured. The aluminium alloy of the aluminium strip produced had thereby the following alloy composition:

Si = 0.6 wt %,
Fe = 0.3 wt %,
Cu = 0.4 wt %,
Mn = 1.3 wt %,
Mg = 0.3 wt %,
Cr = 0.1 wt %,
Zn = 0.01 wt %,
Ti = 0.02 wt %,

unavoidable impurities separately representing a maximum of 0.1 %, together a maximum of 0.15%, and the remainder being aluminium.

Subsequent to brazing, the heat resistance was determined by measuring the yield strength. The yield strength $R_{p0.2}$ was 72 MPa at a test temperature of 250 °C. Conventional aluminium alloys have markedly lower yield strengths, in particular at test temperatures of 250° C. The yield strengths of the aluminium alloys typically used for tubes of a heat exchanger are below 65 MPa at room temperature. For example, subsequent to brazing at a temperature of 250° C, a conventional alloy AA3003 has

only a yield strength $R_{p0.2}$ of less than 40 MPa. As a result of the gain in heat resistance, with the aluminium alloy according to the invention and the aluminium strip according to the invention it is possible to further reduce the wall thicknesses of the tubes, tube plate, side parts and disks of a heat exchanger, without endangering the operating safety of the heat exchangers.

CLAIMS

1. A method for producing an aluminium strip or aluminium sheet for heat exchangers from a heat resistant aluminium alloy, wherein the aluminium alloy comprises the following proportions of alloy components in weight percent:

0.3 % ≤ Si ≤ 1 %,
Fe ≤ 0.5 %,
0.3 % ≤ Cu ≤ 0.7 %,
1.1 % ≤ Mn ≤ 1.8 %,
0.15 % ≤ Mg ≤ 0.6 %,
0.01 % ≤ Cr ≤ 0.3 %,
Zn ≤ 0.10 %,
Ti ≤ 0.3 %,

unavoidable impurities separately representing a maximum of 0.1 %, together a maximum of 0.15 %, and the remainder being aluminium, wherein a rolling ingot is cast in a continuous casting process, the rolling ingot is preheated at 400 to 500°C prior to hot rolling, the rolling ingot is rolled to a hot strip, with the hot strip temperature being 250 to 380 °C and the hot strip thickness being 3 to 10 mm at the end of the hot rolling and the hot strip is cold rolled to final thickness.

2. A method for producing an aluminium strip or aluminium sheet for heat exchangers according to claim 1, wherein the aluminium alloy comprises the following proportions of alloy components in weight percent:

$$0.15 \% \leq \text{Mg} \leq 0.3 \%$$
$$\text{Zn} \leq 0.05 \%$$
$$0.01 \% \leq \text{Ti} \leq 0.3 \%$$

5

3. A method for producing an aluminium strip or aluminium sheet for heat exchangers according to claim 1 or 2, wherein the aluminium alloy comprises the following proportions of the alloy components Si, Fe, Mn in weight percent:

10

$$0.5 \% \leq \text{Si} \leq 0.8 \%,$$
$$\text{Fe} \leq 0.35 \%,$$
$$1.1 \% \leq \text{Mn} \leq 1.5 \%$$

15

4. A method for producing an aluminium strip or aluminium sheet for heat exchangers according to any one of claims 1 to 3, wherein the rolling ingot is homogenized prior to the preheating.

20

5. A method for producing an aluminium strip or aluminium sheet for heat exchangers according to any one of claims 1 to 4, wherein the hot strip is intermediately annealed at a temperature of 300 to 450 °C.

25

6. A method for producing an aluminium strip or aluminium sheet for heat exchangers according to any one of claims 1 to 5, wherein, during the cold rolling, the aluminium strip is intermediately annealed at a temperature of 300 to 450 °C prior to reaching the final thickness.

30

7. A method for producing an aluminium strip or aluminium sheet for heat exchangers according to any one of claims 1 to 6, wherein subsequent to the cold rolling, a phase annealing step to the final state takes place at a temperature of 250 to 400 °C.
8. A method for producing an aluminium strip or aluminium sheet for heat exchangers according to any one of claims 1 to 7, wherein prior to the preheating, the rolling ingot is provided on one or two sides with plates made of another alloy.
9. A method for producing an aluminium strip or aluminium sheet for heat exchangers according to claim 8, wherein the plates are comprised of a solder alloy and as the solder alloy there is used an aluminium solder.
10. A method for producing an aluminium strip or aluminium sheet for heat exchangers according to claim 9, wherein the aluminium solder is an aluminium alloy comprising 6 to 13 weight percent Si.
11. A method for producing an aluminium strip or aluminium sheet for heat exchangers according to claim 9, wherein the aluminium solder is an AlSi7.5 alloy or AlSi10 alloy.
12. A method for producing an aluminium strip or aluminium sheet for heat exchangers according to any one of claims 1 to 11, wherein the hot strip is cold rolled to a final thickness of 0.1 to 2.0 mm.

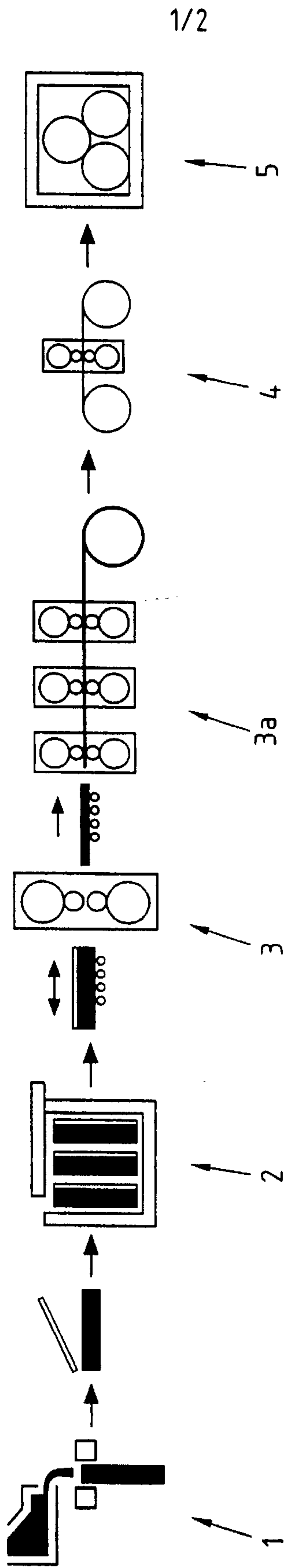

Fig.1

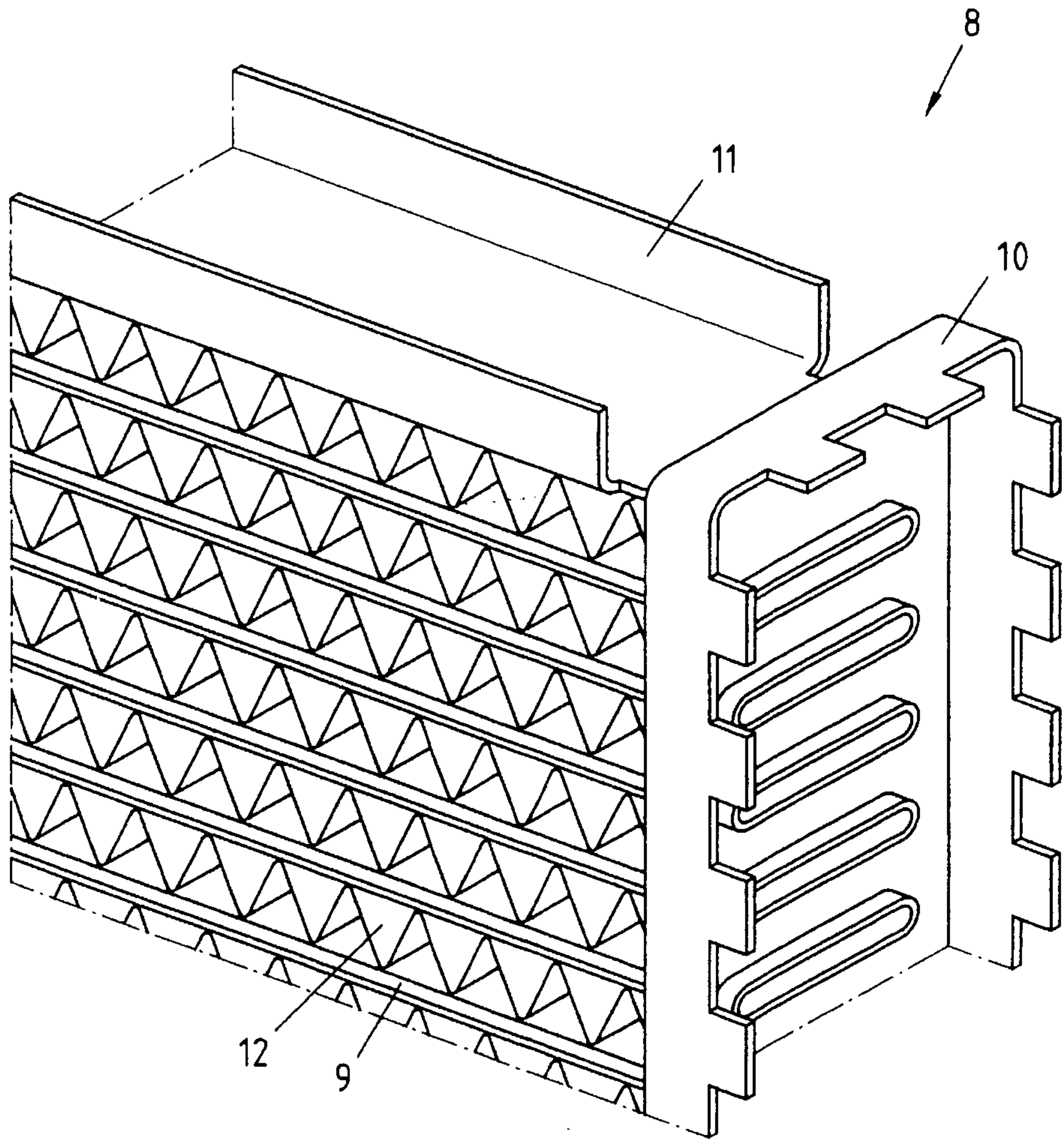

Fig.2