

(19)



(11)

EP 2 444 334 B1

(12)

EUROPEAN PATENT SPECIFICATION

(45) Date of publication and mention
of the grant of the patent:
27.11.2013 Bulletin 2013/48

(51) Int Cl.:
B65D 41/46 (2006.01) B65D 41/62 (2006.01)

(21) Application number: **10460040.8**

(22) Date of filing: **28.09.2010**

(54) **Safety bottle cap**

Sicherheitsflaschendeckel

Bouchon de bouteille sécurisé

(84) Designated Contracting States:
**AL AT BE BG CH CY CZ DE DK EE ES FI FR GB
GR HR HU IE IS IT LI LT LU LV MC MK MT NL NO
PL PT RO SE SI SK SM TR**
Designated Extension States:
BA ME RS

(43) Date of publication of application:
25.04.2012 Bulletin 2012/17

(73) Proprietor: **CEDC International sp. z.o.o.
64-600 Oborniki Wielkopolskie (PL)**

(72) Inventor: **Klopocki, Marek
81-554 Gdynia (PL)**

(74) Representative: **Lazewski, Marek
LDS Lazewski Depo & Partners
ul. Myslowicka 15
01-612 Warszawa (PL)**

(56) References cited:
**FR-A- 1 393 366 US-A1- 2005 077 263
US-A1- 2008 073 382**

EP 2 444 334 B1

Note: Within nine months of the publication of the mention of the grant of the European patent in the European Patent Bulletin, any person may give notice to the European Patent Office of opposition to that patent, in accordance with the Implementing Regulations. Notice of opposition shall not be deemed to have been filed until the opposition fee has been paid. (Art. 99(1) European Patent Convention).

Description

[0001] The present invention is related to a safety bottle cap adjusted for closing bottle head opening. The cap according to the invention is provided with a control element that is partially destroyed in a visible manner after being opened for the first time. This prevents a bottle containing certain liquid (such as alcoholic beverage) from being refilled with a substitute amount of other liquid of characteristics and quality possibly differing from the original content. At the same time the safety bottle cap still realises its primary function of closing the bottle head opening.

[0002] Many different types of bottle closures are known in the prior art including threaded caps, covers or more complex closures provided with various types of valves (see for example US 2008/073 382, upon which the preamble of claim 1 is based).

[0003] For example, in EP 1574450 B1 a safety bottle cap is disclosed comprising a screw cap threadedly engaged with an external sleeve connected to an internal sleeve by means of ribs in such a way that through channels are formed. The cap is provided i.a. with two-part metal enclosure, while the protection against refilling is realised by a combination of protection band and hydraulic interlocking.

[0004] Further, in FR 2908746 A1 a cap for being forced onto a bottle head is disclosed, the the cap being provided with a lateral tubular skirt. The lower part of the skirt is formed as a band which on its internal side has a peripheral protrusion maintaining this element around the bottle neck, in particular when the cap is being opened. On a part of the lateral skirt perimeter there is a horizontal line of weakness allowing the cap to be partially torn off and the closure to be opened. The cap comprises a special protrusion that facilitates the cap to be levered. However, the cap does not comprise a metal cover, and once the cap is taken of for the first time the control band remains as a one-piece element around the bottle neck.

[0005] Yet further, in RU 2307056 C1 a bottle closure is disclosed having a metal cover consisting of a cap connected via plurality of frangible bridges to a lateral cover and of a polymer insert. The polymer insert is shaped so as to both penetrate the bottle head opening and enclose it so as to form a screw joint with the outer thread of the bottle head. Breaking the bridges between the cap (firmly connected to the polymer insert) and the lateral cover takes place as a result of the cap being twisted with respect to the lateral cover in the direction defined by above-mentioned screw joint.

[0006] Moreover, in RU 81480 (U1) bottle cap is described with a tearable element forming the lower part of the cap. This part is conected via plurality of tearable bridges to the cap's upper part enclosing the bottle head and also is provided with a protrusion being inserted into the bottle head opening. The upper part of the cap comprises a metal cover, lower edge thereof being turned down in form of a lip that during the cap production snaps

into specifically formed peripheral groove in the upper part of the plastic cap body.

[0007] Despite numerous solutions related to closures protecting bottles againts unauthorised refilling, there is a clear constant need for development of new bottle closures characterised by considerably high protection level combined with possibly simple construction, not requiring costly setting-up (as in case of multi-element valve systems), allowing for aesthetic appearance, safe use (no sharp edges or protruding elements left after the removal of a control band) and sufficient closure sealing also once the control band is removed. The aim of the invention was to provide a solution meeting these requirements and providing an attractive alternative for the existing solutions.

[0008] The safety bottle cap according to the present invention is defined in the indepedent claim 1. Preferred embodiments thereof are presented in subsequent dependent claims.

[0009] The invention is illustrated with drawings, wherein Fig. 1A shows a cross-section of the cap according to the invention; Fig. 1B shows an end view of the cap according to the invention; Fig. 1C shows a top view of the cap according to the invention; Fig. 2 shows an end view of a plastic body of the cap according to the invention; and Fig. 3 shows a perspective view of the cap according to the invention.

[0010] As shown in Fig. 1A, the safety bottle cap according to the invention consists of a metal cover 1 connected to a body 2 made of plastic such as poliethylene or polypropylene.

[0011] Preferably, the metal cover 1 is made of steel. Surface of the metal cover 1 is smooth which allows a decoration to be made thereon, for example in form of a print, whereby the decoration may be made on the top surface of the cover as well as on its peripheral lateral surface.

[0012] Preferably, the metal cover 1 is connected to the plastic body 2 by means of an adhesive, in particular a hot melt adhesive.

[0013] The plastic body 2 is combined of two parts connected to each other by a plurality of tearable bridges 3. The upper part of the body 2 comprises a sealing element 4 to be introduced into the bottle head opening and a sealing lip 5, directed externally at an angle with respect to the cap rotation axis B. The sealing lip 5 also compensates axial clearance of the cap on the bottle head. Further, the upper part of the body 2 comprises a plurality of inner ribs 6 located peripherally at the inner side of the body 2 contacting the outer peripheral bottle head surface, as well as a plurality of outer ribs 7 (Fig. 2). The inner ribs 6 serve for centering the cap on the bottle head and prevent the cap from rotation. The inner ribs 7 serve for centering the metal cover 1. On its lower peripheral edge the upper part of the body 2 has a ring-shaped protrusion 8 extending externally in radial direction beyond the outline of the metal cover 1. The ring-shaped protrusion 8 serves for masking the edge of the metal

cover 1. As shown in Fig. 1C on the lower peripheral edge the upper part of the body 2 comprises also a radial protrusion 9 facilitating the cap removal once the control ring is removed.

[0014] The lower part of the cap body 2 is formed as a tearable control ring, which prevents the bottle from being refilled without a visible signs of unauthorised opening of the cap. The first opening of the bottle requires complete tearing of the control ring from the upper part of the body 2. The control ring comprises a protecting collar 10 directed at an angle to the inside of the ring, the collar 10 engaging into and snapping at an annular groove respectively formed in the bottle head outer surface, thereby preventing the cap from being taken off the bottle head without tearing off the control ring.

[0015] The tearable bridges 3 connecting the upper and lower part of the body 2 can be elongated - respectively - in form of a plurality of inner ribs 6 in the upper part of the body 2 and in form of a plurality of corresponding ribs located peripherally at the inner side of the control ring above the protecting collar 10. Such elongated bridges 3 may also protect the cap from rotating on the bottle head.

[0016] As shown in Fig. 1B the control ring is provided with a tongue 11 facilitating tearing off the control ring from the upper part of the cap body 2. During the formation process the control ring is vertically cut so as to allow it to be torn off by pulling the tongue 11 using considerably little force, thereby eliminating the probability of a complete cap being reused for closing a bottle refilled with non-original content. The tongue 11 is protected from protruding too much and the associated risk of uncontrolled tearing off or straining the bridges 3 by the fact that in its lower part the tongue 11 has tearable bridges 12 (preferably two) connecting the tongue 11 with the lower part of the control ring, and by the fact that in its upper part the tongue 11 has a tearable bridge 13 connecting the tongue 11 with the upper part of the cap body 2. The bridges 12 also prevent the tongue 11 from being torn or strained during the application of the complete cap onto the bottle head realised by pressing the cap against the bottle head using the force directed vertically downwards.

[0017] The tongue 11 is formed in mould slides being opened perpendicularly to the cap rotation axis B. Further, the formation of incision of the bridges 3 in the cap of the invention is realised by means of slides being opened perpendicularly to the cap rotation axis B.

Claims

1. A safety bottle cap comprising a plastic body (2) consisting of two parts connected by a plurality of tearable bridges (3), whereby the upper part of the body (2) comprises a sealing element (4) to be introduced into the bottle head opening, a sealing lip (5), a plurality of peripherally located outer ribs (7), and the

lower part of the body (2) is in a form of a cut tearable control ring comprising a protecting collar (10) directed at an angle to the inside of the ring, the collar (10) engaging into and snapping at an annular groove respectively formed in the bottle head outer surface, whereby the upper part of the body (2) is provided with a plurality of inner ribs (6) located peripherally at the inner side of the body (2) contacting the outer peripheral bottle head surface **characterised in that** a metal cover (1) is connected to the plastic body, the control ring further comprises a tongue (11) for tearing off the control ring, provided in its lower part with tearable bridges (12) connecting the tongue to a lower part of the control ring and **in that** the upper part of the body (2) on its lower peripheral edge has a ring-shaped protrusion (8) extending externally in radial direction beyond the outline of the metal cover (1).

2. The safety bottle cap according to claim 1, **characterised in that** the metal cover (1) is connected to the plastic body (2) by means of an adhesive.
3. The safety bottle cap according to claim 1 or 2, **characterised in that** the upper part of the body (2) on its lower peripheral edge has a radial protrusion (9) facilitating the cap removal once the control ring is removed.
4. The safety bottle cap according to any of the claims 1 to 3, **characterised in that** the sealing lip (5) is directed externally at an angle with respect to the cap rotation axis B.
5. The safety bottle cap according to any of the claims 1 to 4, **characterised in that** in its lower part the tongue (11) is provided with two tearable bridges (12) connecting the tongue (11) to a lower part of the control ring.
6. The safety bottle cap according to any of the claims 1 to 5, **characterised in that** in its upper part the tongue (11) is provided with a tearable bridge (13) connecting the tongue (11) to the upper part of the cap body (2).
7. The safety bottle cap according to any of the claims 1 to 6, **characterised in that** the inner ribs (6) form an elongated continuation of tearable bridges (3) in the upper part of the body (2), and that a plurality of peripherally located ribs forming an elongated continuation of tearable bridges (3) is provided at the inner side of the control ring above the protecting collar (10).

Patentansprüche

1. Sicherheitsflaschendeckel mit Körper (2) aus Kunststoff, der aus zwei Teilen besteht, die mit einer Mehrzahl von abreißbaren Brücken (3) miteinander verbunden sind, wobei der obere Teil des Körpers (2) einen Abdichtungselement (4), das zur Einführung in die Öffnung im Flaschenkopf vorgesehen ist, eine Abdichtungslippe (5), eine Mehrzahl von umlaufend angeordneten Außenrippen (7) besitzt, und der untere Teil des Körpers (2) die Form des durchgeschnittenen abreißbaren Kontrollringes mit Schutzkragen (10) hat, der unter einem Winkel zum Inneren des Ringes ausgerichtet ist, wobei der Kragen (10) in dem entsprechend gestalteten Ringnut in der Außenfläche des Flaschenkopfes reingeht und einschnappt, und wobei der obere Teil des Körpers (2) mit einer Mehrzahl der Innenrippen (6) ausgestattet ist, die auf den Innenseite des Körpers (2), die mit der umlaufenden Außenfläche des Flaschenkopfes in Berührung kommt, angeordnet sind, **dadurch gekennzeichnet, dass** an den Körper aus Kunststoff die Metallkapsel (1) befestigt ist, der Kontrollring zusätzlich eine Zunge (11) zum Abreißen des Kontrollringes besitzt, die in ihrem unteren Teil die abreißbaren Brücken (12) besitzt, die die Zunge mit dem unteren Teil des Kontrollringes verbindet, und der obere Teil des Körpers (2) auf ihrem unteren umlaufenden Rand den ringförmigen Vorsprung (8) besitzt, der nach Außen in radialer Richtung außerhalb der Kontur der Metallkapsel (1) hervorsticht.
2. Sicherheitsflaschendeckel nach dem Anspruch 1, **dadurch gekennzeichnet, dass** die Metallkapsel (1) mit dem Körper (2) aus Kunststoff mit Hilfe von einer Klebe verbunden ist.
3. Sicherheitsflaschendeckel nach dem Anspruch 1 oder 3, **dadurch gekennzeichnet, dass** der obere Teil des Körpers (2) auf ihrem unteren umlaufenden Rand den radialen Vorsprung (9) besitzt, der das Abnehmen den Deckel nach dem Abreißen des Kontrollringes erleichtert.
4. Sicherheitsflaschendeckel nach einem der Ansprüche von 1 bis 3, **dadurch gekennzeichnet, dass** die Abdichtungslippe (5) nach Außen unter einem Winkel gegenüber der Deckeldrehachse B ausgerichtet ist.
5. Sicherheitsflaschendeckel nach einem der Ansprüche von 1 bis 4, **dadurch gekennzeichnet, dass** die Zunge (11) in ihrem unteren Teil mit zwei abreißbaren Brücken (12) ausgestattet ist, die die Zunge (11) mit dem unteren Teil des Kontrollringes verbinden.
6. Sicherheitsflaschendeckel nach einem der Ansprü-

che von 1 bis 5, **dadurch gekennzeichnet, dass** die Zunge (11) in ihrem oberen Teil mit einer abreißbaren Brücke (13) ausgestattet ist, die die Zunge (11) mit dem oberen Teil des Körpers (2) des Deckels verbindet.

7. Sicherheitsflaschendeckel nach einem der Ansprüche von 1 bis 6, **dadurch gekennzeichnet, dass** die Innenrippen (6) die Verlängerung der abreißbaren Brücken (3) im oberen Teil des Körpers (2) darstellen, und dass auf der Innenseite des Kontrollringes über dem Schutzkragen (10) eine Mehrzahl von umlaufenden Rippen angeordnet ist, die die Verlängerung der abreißbaren Brücken (3) darstellen.

Revendications

1. Opercule de protection pour une bouteille comprenant un corps (2) en matière plastique composé de deux parties liées par un certain nombre de ponts arrachables (3), la partie supérieure du corps (2) comportant un élément d'étanchéité (4) destiné à être introduit dans l'ouverture de la tête de la bouteille, une lèvre d'étanchéité (5), un certain nombre d'ailettes extérieures (7) disposées en périphérie, la partie inférieure du corps (2) ayant la forme d'une bague de contrôle coupée arrachable munie d'une bride de protection (10) dirigée sous un certain angle vers l'intérieur de la bague, où la bride (10) entre et se verrouille dans une gorge annulaire convenablement conformée dans la surface extérieure de la tête de la bouteille, et la partie supérieure du corps (2) étant munie d'un certain nombre d'ailettes intérieures (6) disposées en périphérie sur la partie intérieure du corps (2) qui reste en contact avec la surface périphérique extérieure de la tête de la bouteille, **caractérisé en ce qu'une** capsule métallique (1) est fixée au corps en matière plastique (1), la bague de contrôle comporte en outre une languette (11) pour arracher la bague de contrôle, munie dans sa partie inférieure de ponts arrachables (12) liant la languette à la partie inférieure de la bague de contrôle, et que la partie supérieure du corps (2) comporte sur son bord périphérique inférieur une saillie annulaire (8) débordant vers l'extérieur dans la direction radiale en dehors du contour de la capsule métallique (1).
2. Opercule de protection pour une bouteille selon la revendication 1, **caractérisé en ce que** la capsule métallique (1) est liée au corps (2) en matière plastique à l'aide d'une colle.
3. Opercule de protection pour une bouteille selon la revendication 1 ou 3, **caractérisé en ce que** la partie supérieure du corps (2) comporte sur son bord périphérique inférieur une saillie radiale (9) facilitant l'enlèvement de l'opercule après l'arrachage de la

bague d'inviolabilité.

4. Opercule de protection pour une bouteille selon l'une quelconque des revendications 1 à 3, **caractérisé en ce que** la lèvre d'étanchéité (5) est dirigée vers l'extérieur sous un certain angle par rapport à l'axe de rotation B de l'opercule. 5
5. Opercule de protection pour une bouteille selon l'une quelconque des revendications 1 à 4, **caractérisé en ce que** la languette (11) est munie dans sa partie inférieure de deux ponts arrachables (12) liant la languette (11) à la partie inférieure de la bague d'inviolabilité. 10
15
6. Opercule de protection pour une bouteille selon l'une quelconque des revendications 1 à 5, **caractérisé en ce que** la languette (11) est munie dans sa partie supérieure d'un pont arrachable (13) liant la languette (11) à la partie supérieure du corps (2) de l'opercule. 20
7. Opercule de protection pour une bouteille selon l'une quelconque des revendications 1 à 6, **caractérisé en ce que** les ailettes intérieures (6) constituent le prolongement des ponts arrachables (3) dans la partie supérieure du corps (2), et qu'en plus sur la partie intérieure de la bague d'inviolabilité au dessus de la bride de protection (10) se trouvent bien des ailettes disposées en périphérie constituant le prolongement des ponts arrachables (3). 25
30

35

40

45

50

55

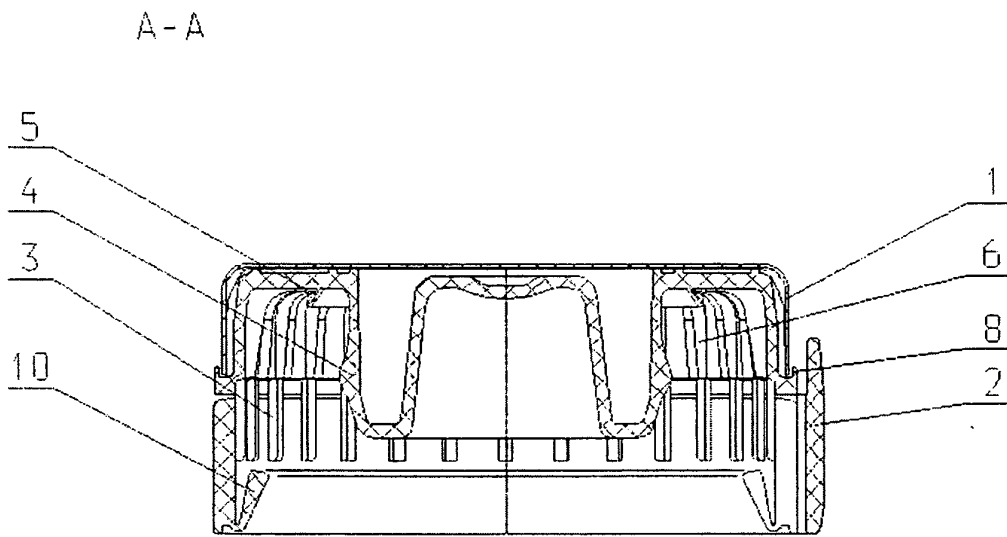

FIG. 1A

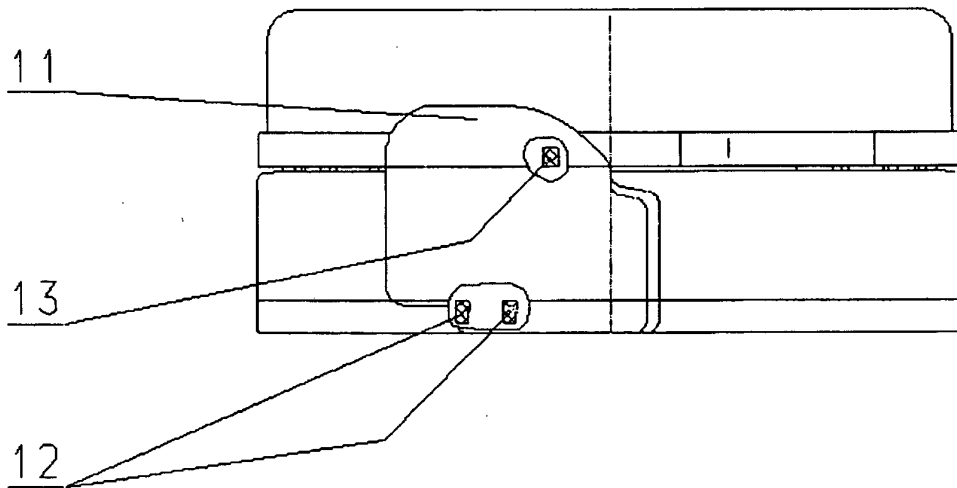
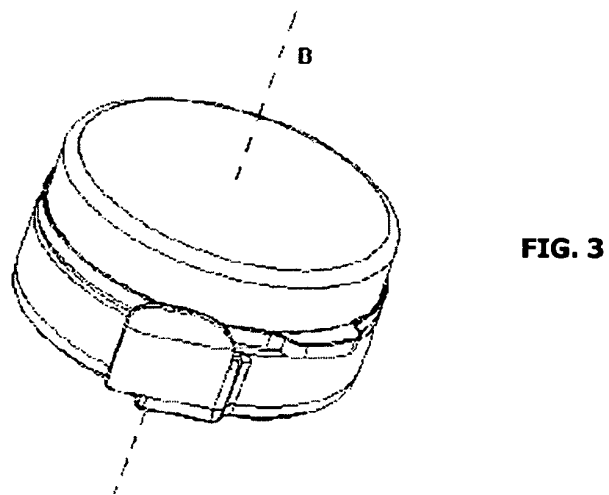
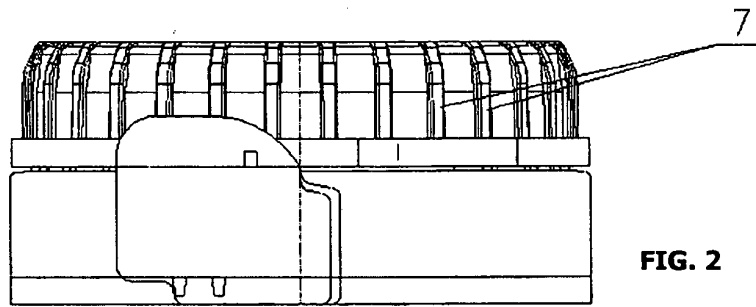
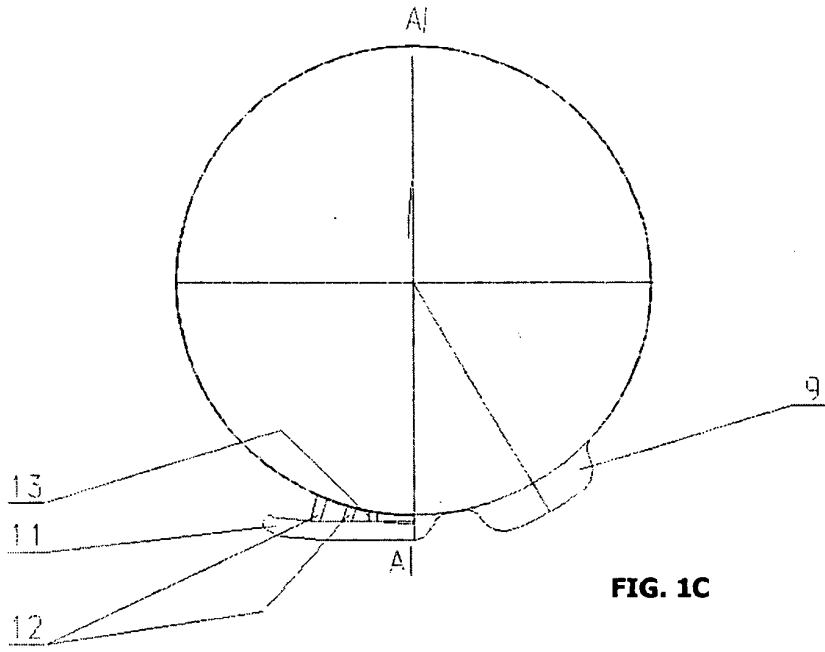

FIG. 1B



REFERENCES CITED IN THE DESCRIPTION

This list of references cited by the applicant is for the reader's convenience only. It does not form part of the European patent document. Even though great care has been taken in compiling the references, errors or omissions cannot be excluded and the EPO disclaims all liability in this regard.

Patent documents cited in the description

- US 2008073382 A [0002]
- EP 1574450 B1 [0003]
- FR 2908746 A1 [0004]
- RU 2307056 C1 [0005]
- RU 81480 U1 [0006]