

(No Model.)

2 Sheets—Sheet 1.

F. S. GRAY.
GATE.

No. 521,880.

Patented June 26, 1894.

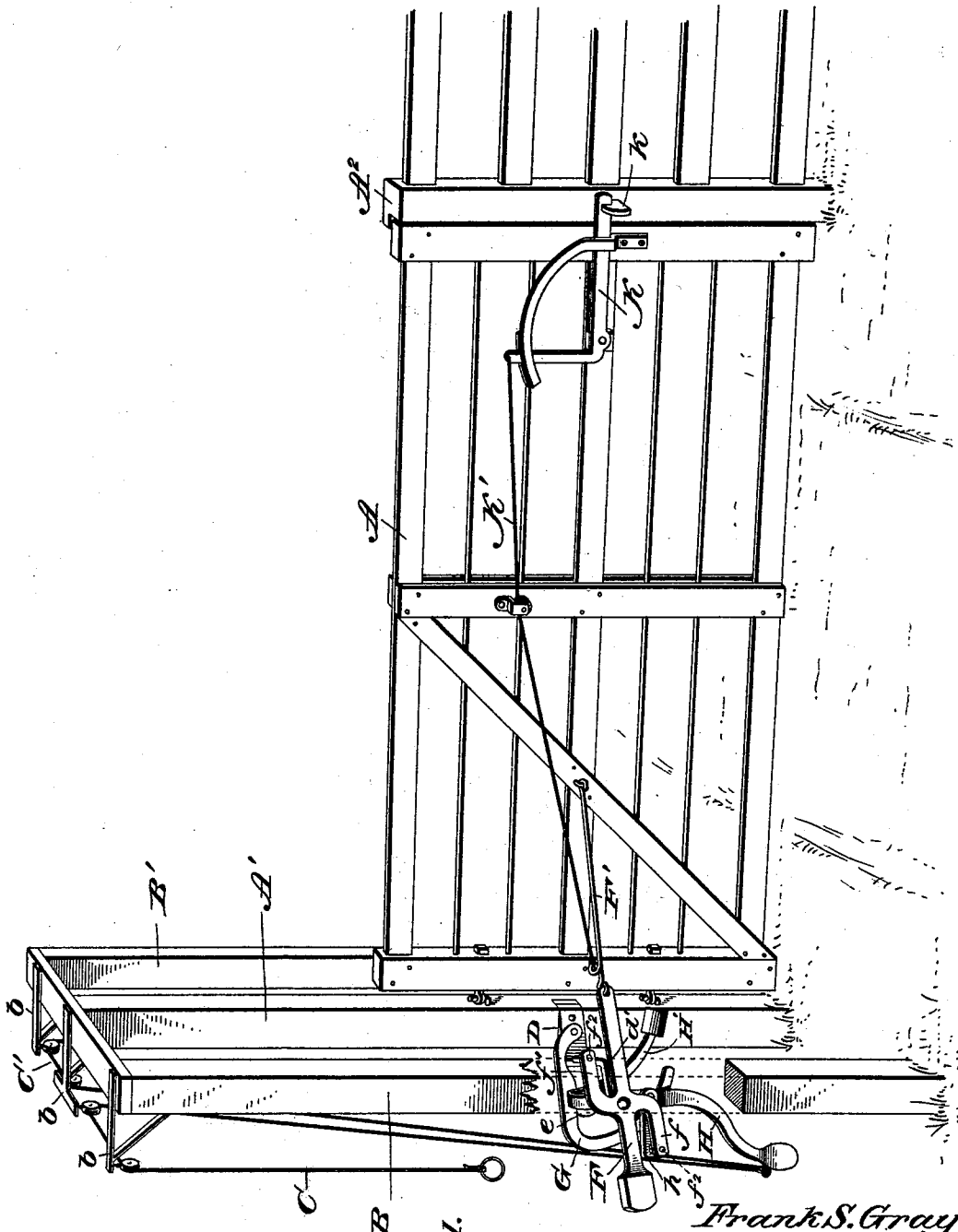

WITNESSES
G. S. Elliott.
A. W. Johnson

Fig. 1.

— by *[Signature]*

Frank S. Gray
INVENTOR

Attorney

No. 521,880.

Patented June 26, 1894.

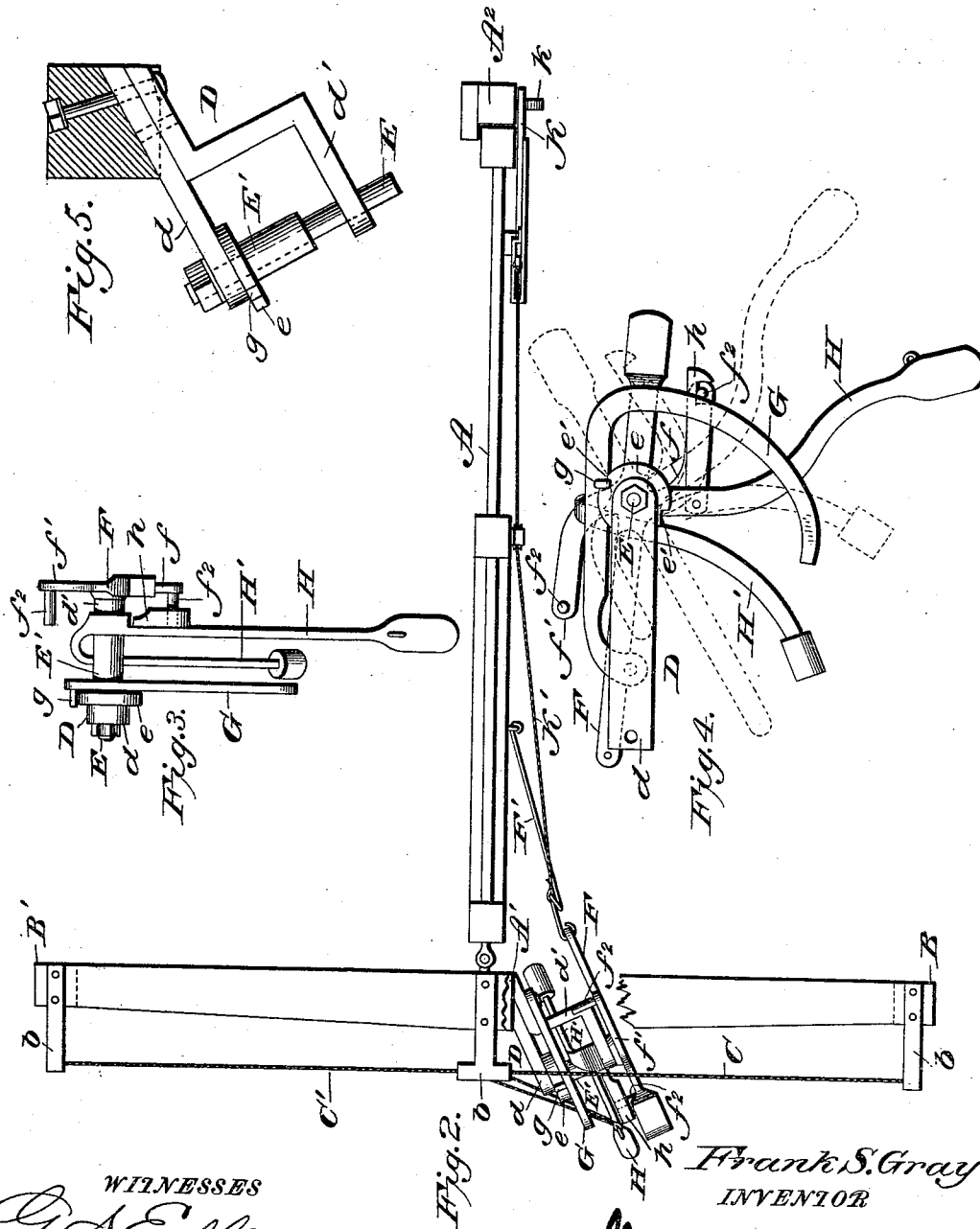

WITNESSES
G. S. Elliott,
W. Johnson

Frank S. Gray
 INVENTOR
 by *W. Johnson*
 Attorney

UNITED STATES PATENT OFFICE.

FRANK S. GRAY, OF TRENTON, KENTUCKY.

GATE.

SPECIFICATION forming part of Letters Patent No. 521,880, dated June 26, 1894.

Application filed February 8, 1894. Serial No. 449,508. (No model.)

To all whom it may concern:

Be it known that I, FRANK SANDERS GRAY, a citizen of the United States of America, residing at Trenton, in the county of Todd and State of Kentucky, have invented certain new and useful Improvements in Gates; and I do hereby declare the following to be a full, clear, and exact description of the invention, such as will enable others skilled in the art to which it appertains to make and use the same, reference being had to the accompanying drawings, and to letters of reference marked thereon, which form a part of this specification.

This invention relates to improvements in swinging gates of that class which are adapted to be either opened or closed before the gate is reached by operating suitable mechanism. And the invention consists in the combination with a swinging gate of certain mechanism which is adapted when operated to release the latch of the gate and swing the same to a position at right-angles to the driveway where it is retained or locked until the mechanism is again operated to close the gate.

The invention further consists in the construction and combination of the parts, as will be hereinafter fully set forth and particularly pointed out in the claims.

In the accompanying drawings, forming part of this specification, Figure 1 is a perspective view showing a gate with my improved mechanism applied. Fig. 2 is a plan view. Fig. 3 is a detail view of a part of the operating mechanism. Fig. 4 is a side view of the operating mechanism, and Fig. 5 is a detail view of the frame which supports the operating mechanism.

A designates the gate which is hung upon a post A¹ in the usual manner so that when closed it will abut against the post A². At a suitable distance on each side of the post A¹ are posts B and B', and these posts may be connected to each other at their upper ends as shown and are provided with suitable brackets b supporting suitable rollers or pulleys over which flexible connections C and C' pass to the operating mechanism.

D designates the supporting frame for the gate operating mechanism which is rigidly attached to the post A¹ and consists of two members d and d' the outer ends of which are apertured to provide bearings for a shaft E.

On the outer end of the shaft E is rigidly mounted a weighted bar F having members f and f' which project in opposite directions and extend parallel with said bar. The outer ends of the members f and f' are provided with projecting-pins f² with which a pawl engages to rotate the weighted bar and shaft upon which it is mounted, as hereinafter set forth.

Upon the shaft E adjacent to the member d of the frame D is rigidly mounted a disk or collar e having notches e' in its periphery with which a pawl G engages to prevent backward rotation of the shaft E. This pawl is pivoted to the frame D and has its free end weighted and is provided with a projecting pin g which engages the notches of the disk e. The shaft E also carries a weighted lever H which is loosely mounted thereon and is extended at its inner end to provide a member H' which is weighted and bent around the shaft to project nearly parallel with the lever. The lever is located on the other side of the member d' of the frame D from the weighted bar F and is retained in place by a collar E' interposed between said lever and the disk e, and this lever is provided with a pawl or dog h which is pivoted thereto and is adapted to engage with the projecting pins f² of the members f and f' of the weighted bar F so that by elevating the lever the pawl being in engagement with one of the projecting pins will carry with it the weighted bar F to give a half rotation to the same, its backward rotation being prevented by the pawl G engaging one of the notches in the disk e, and when the weighted lever is lowered the pawl thereon will engage the other pin, f², to complete the rotation of the bar F. The lever H is operated, or elevated, by the flexible connections C and C' which are attached to the outer end of the same, and the gate by its connection with the rotatable bar F is opened and closed by each rotation of the same. The rod F' which connects the gate to the rotatable bar is pivoted to said bar and to the gate as shown, so that in opening the gate the rotatable bar pulls upon the connecting-rod and in closing the gate pushes upon the same. It will be noted that the weighted member H' of the lever H is provided for the purpose of returning the lever

to its normal position when the pull upon the flexible connections is released, as the end of the lever is thrown a slight distance beyond a vertical position when drawn upon by the said flexible connections.

K designates the latch of the gate which is adapted to engage with the catch k attached to the post A^2 . The latch is provided with an upwardly projecting member which is connected to the rod F' by a flexible connection K' , said flexible connection passing through a pulley attached to the gate A as shown. By connecting the latch to the connecting-rod F' as hereinbefore described when the rotatable bar is operated to open the gate it will depress the outer end of said connecting rod and draw upon the flexible connection to first release the latch.

In operation, assuming the gate to be closed and the latch in engagement with the catch the gravity pawl G would be in engagement with one of the notches in the periphery of the disk e and prevent the backward rotation of the shaft E and the movement of the parts attached thereto, so that a person on foot wishing to pass through the gate can by simply elevating the latch partially open the gate without disturbing the operating mechanism. A person on horseback or in a vehicle approaching the gateway simply draws upon one of the flexible connections C' which elevates the lever H and the pawl thereon being in engagement with one of the pins f^2 will rock the weighted bar F which by means of its connection with the gate and gate-latch will first operate the latch and then pull upon the gate to open the same, the shaft turning with the weighted bar F brings the notch in the disk e in engagement with the weighted pawl G so as to prevent backward rotation of said shaft and hold the gate open until the weighted bar is again operated by drawing upon the other flexible connection, the weighted lever falling by gravity and the pawl thereon engaging the other pin f^2 , so that by again elevating the lever the weighted bar will complete its rotation and close the gate bringing the parts to their original position.

It will be noted that by the construction hereinbefore described the weighted-bar F is given a complete rotation on the opening and closing of the gate and that the pawl on the lever H is moved in contact with the pins on said bar by gravity.

Having thus described my invention, what I claim as new, and desire to secure by Letters Patent, is—

1. In combination with a swinging gate having a latch, a rotatable bar suitably supported, and means for turning said bar, a rod con-

necting the bar to the gate and a flexible connection extending from the latch to a point adjacent to where the rotatable bar and rod are connected, substantially as shown, whereby the elevation or depression of the bar will cause the latch to be released.

2. In a swinging gate, the combination, of a supporting frame mounted so as to be out of line with the gate, and supporting a shaft, a rotatable bar mounted on the shaft and having projecting pins, a weighted lever loosely mounted on the shaft and provided with a pawl which is adapted to engage with the pins, a disk rigidly attached to the shaft and provided with notches with which a pawl engages, (the rotatable bar being connected to the gate by a rod,) and means for elevating the weighted lever, substantially as shown and for the purpose set forth.

3. In a swinging gate, means for operating the same comprising flexible connections which extend from a distance on each side of the gate to a weighted lever which is loosely mounted on a shaft, said lever having a pivoted pawl or dog, a rotatable bar connected to the gate and adapted to engage with said pawl, the points of connection of the pawl with the rotatable bar being on opposite sides of the supporting frame for said bar, substantially as shown.

4. In a swinging gate, the combination, of a lever H having weighted ends which do not move in the same plane, said lever carrying a pivoted pawl or dog, and a rotatable bar one end of which is weighted and the other connected to the gate, said bar having members f and f' which extend in opposite directions and have pins with which the pawl or dog engages, substantially as shown and for the purpose set forth.

5. In combination with a swinging gate constructed substantially as shown, a supporting frame D on the gate post a shaft mounted in said frame to which is rigidly connected a disk having notches and a rotatable bar having projecting pins, a weighted lever loosely mounted on the shaft and provided with a pawl or dog having a recess, to engage said pins alternately a pawl pivoted to the frame and engaging the notches of the disk, and flexible connections attached to the weighted lever, substantially as shown and for the purpose set forth.

In testimony whereof I affix my signature in presence of two witnesses.

FRANK S. GRAY.

Witnesses:

J. D. RUTHERFORD,
C. E. BURGE.