

F. A. & H. F. KLOCKSIEM.  
VALVE GEAR FOR HYDROCARBON TRACTION ENGINES.

APPLICATION FILED JUNE 30, 1902.

NO MODEL.

2 SHEETS—SHEET 1.

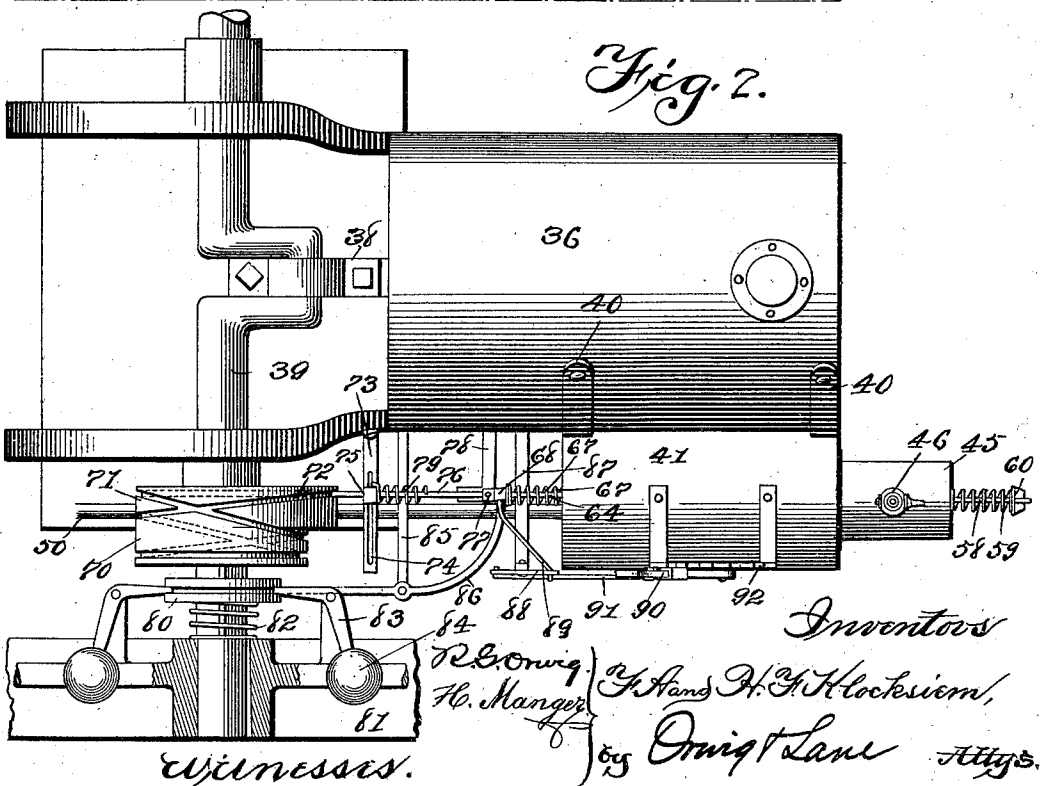
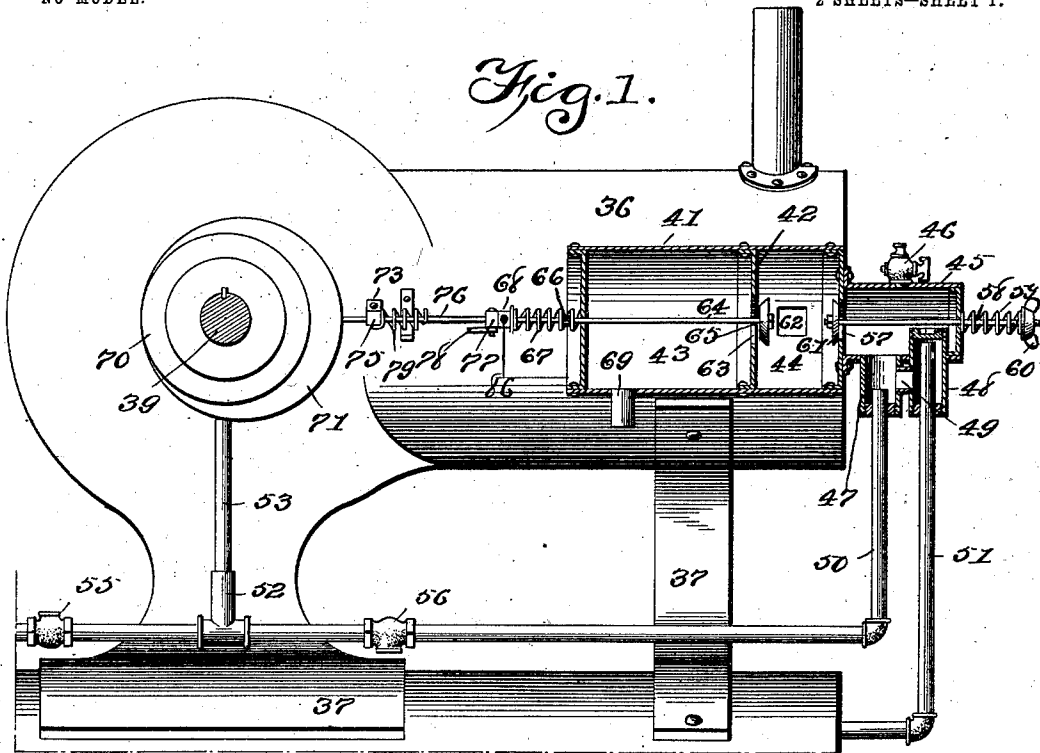

No. 748,509.

PATENTED DEC. 29, 1903.

F. A. & H. F. KLOCKSIEM.  
VALVE GEAR FOR HYDROCARBON TRACTION ENGINES.

APPLICATION FILED JUNE 30, 1902.

NO MODEL.

2 SHEETS—SHEET 2.

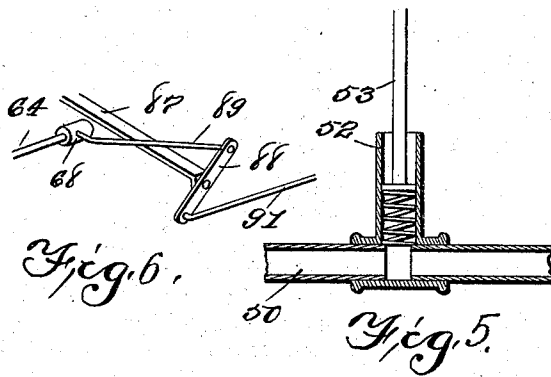
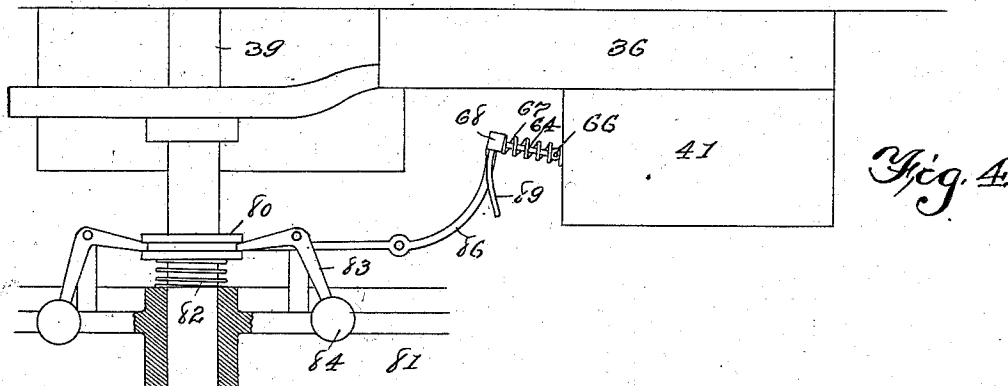
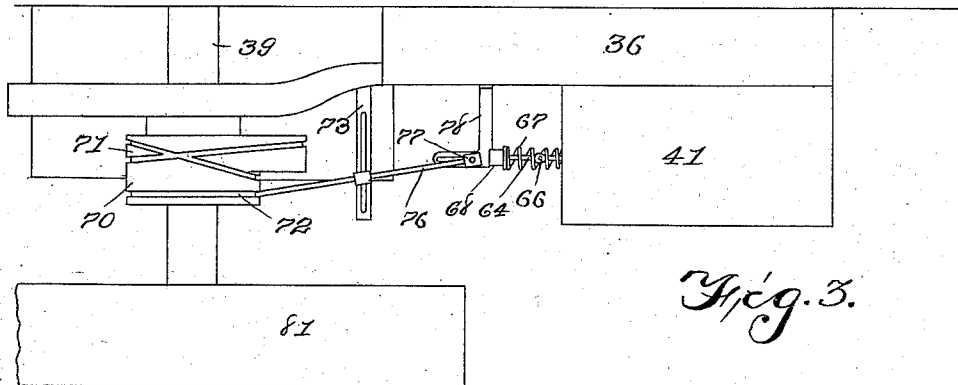

Witnesses:  
R. S. Orwig,  
Henry Manger

Inventors F. A. & H. F. Klocksiam,  
by Orwig & Lane Attys.

# UNITED STATES PATENT OFFICE.

FREDERICK A. KLOCKSIEM AND HENRY F. KLOCKSIEM, OF PATON, IOWA.

## VALVE-GEAR FOR HYDROCARBON TRACTION-ENGINES.

SPECIFICATION forming part of Letters Patent No. 748,509, dated December 29, 1903.

Application filed June 30, 1902. Serial No. 113,746. (No model.)

*To all whom it may concern:*

Be it known that we, FREDERICK A. KLOCKSIEM and HENRY F. KLOCKSIEM, citizens of the United States, residing at Paton, in the county of Greene and State of Iowa, have invented certain new and useful Improvements in Valve-Gear for Hydrocarbon Traction-Engines, of which the following is a specification.

Our object is to provide an improved mixer for vaporizing the hydrocarbon and for introducing it to the engine in measured quantities, and, further, to provide an improved governor automatically controlled by the speed of the engine for regulating the supply of gas passing from the mixer into the engine, so that speed of the engine is automatically maintained at a certain predetermined rate, and, further, to provide means whereby the operator may readily, quickly, and easily stop the flow of gas from the mixer to the engine without stopping the movements of the engine proper.

Our invention consists in certain details in the construction, arrangement, and combination of the various parts of the device, whereby the objects contemplated are attained, as hereinafter more fully set forth, pointed out in our claims, and illustrated in the accompanying drawings, in which—

Figure 1 shows an enlarged detail view showing the hydrocarbon-engine and illustrating the mixer in vertical section adjacent to the engine, also showing the means for automatically controlling the flow of gas from the mixer to the engine. Fig. 2 shows a detail plan view of the hydrocarbon engine and mixer to illustrate the means for automatically actuating the valves for supplying gas to the engine and also our improved governor. Fig. 3 shows a detail plan view of part of the mechanism for controlling the flow of gas from the mixer to the engine, showing the valve-operating rod at the non-effective part of its movement. Fig. 4 shows a detail plan view of the engine and mixer, illustrating the means by which the governor controls the valve for supplying gas to the engine. Fig. 5 shows a detail sectional view of the pump for forcing hydrocarbon from the supply-tank to the mixer.

Supported above a tank or engine body is

a hydrocarbon-engine of the usual construction surrounded by a water-jacket, and inasmuch as the engine cylinder and jacket are of the ordinary form they are not illustrated in detail, the jacket being indicated by the reference-numeral 36 and the supporting-brackets by the numeral 37.

The numeral 38 indicates a pitman-rod for the engine connected with the crank-shaft 39, which extends transversely of the engine-body.

We have provided the following means for supplying hydrocarbon gas in proper quantities and at proper times to the engine. Supported on brackets 40 at one side of the engine-jacket is a cylinder 41, having closed ends, and a transverse partition 42, dividing the cylinders into the compartments 43 and 44. Connected with the compartment 44 is a mixing-cylinder 45, having a cock 46 at its top by which air may be admitted to the mixing-cylinder in proper quantities. At the lower portion of the mixing-chamber is a short tube 47, its lower end being closed and its upper end communicating with the mixing-chamber. Adjacent to this tube 47 is a second tube or overflow-chamber 48, closed at both ends and communicating with the tube 47 by means of the pipe 49. Into the tube 47 we have inserted hydrocarbon-supplying pipes 50, and near the top of the tube 48, at a point a slight distance above the level of the bottom of the mixing-chamber, is an open-ended overflow-pipe 51, its lower end communicating with the upper portion of a fuel-tank. The said pipe 50 communicates at its other end with the fuel-tank at its under portion. We have provided automatic means for pumping hydrocarbon from the tank 27 to the tube 47, as follows: Communicating with the pipe 50 is a small pump 52, having a spring-raised pump-rod 53 in the pump-cylinder, the upper end of which is engaged by an eccentric 54 on the crank-shaft 39, so that the pump is operated during the rotation of said crank-shaft. Connected with the pipe 50 on opposite sides of the pump are the one-way valves 55 and 56. These valves are of the ordinary construction and are arranged to prevent a flow of hydrocarbon from the pump backwardly through the valve 55 to the tank, and the valve 58 is intended to permit the flow of oil

from the pump to the tube 47 and to prevent its return. By means of the mechanism just described it is obvious that a quantity of oil will be maintained at all times in the mixing-chamber at the level of the top of the overflow-pipe, and on account of the peculiar arrangement and construction of the overflow-pipe and tubes 47 and 48, connected by the pipe 49, the hydrocarbon in the mixing-chamber will not splash into the overflow-pipe on account of the irregular movements of the traction-engine.

In use the air is admitted through the cock 46 into the mixing-chamber, and this air passes over the body of hydrocarbon and thereby becomes mixed with the vapor arising from the hydrocarbon to such an extent as to carry a sufficient quantity of gas with it from the mixing-chamber. The outlet for the mixing-chamber is indicated by the numeral 57, and communication is established by means of said outlet between the mixing-chamber and the chamber 44. The numeral 58 indicates a valve-stem passed through the mixer and having an adjustable spring 59 thereon controlled by the winged nut 60 to normally hold the valve 61 on the outer end of the stem 58 in position to close the opening 57, and the gas in the mixer is only permitted to pass from the mixer to the chamber 44 when a vacuum of sufficient amount is formed in the chamber 44. Thereupon the valve 61 is opened against the pressure of the spring 59 and the contents of the mixer admitted to the chamber 44. This chamber 44 communicates with the interior of the engine through the opening 62, and in the partition 42 is an opening 63. A valve-stem 64, having a valve 65 thereon, passes through the opening 63, with the valve 65 normally within the chamber 44. The said valve-stem 64 is hinged at 66 beyond the end of the cylinder 41, and an extensile spring 67 on the projecting end of the valve-stem normally holds the valve 65 in its closed position, and on the end of the valve-stem opposite from the valve is a block 68. The chamber 43 is provided with an exhaust-opening 69.

From the foregoing description it is obvious that the valve 65 is normally held closed by the pressure of the spring 67 unless greater pressure is applied to the block 68, and, furthermore, when the valve 65 is held closed it is obvious that the engine cannot work, because its exhaust-opening is closed. The valve 61 is opened only by suction on the interior of chamber 44, and obviously there can be no suction in this chamber unless the engine can exhaust. Therefore the operation of the engine is entirely controlled by valve 65.

We have provided means whereby the valve 65 is opened automatically during each third cycle of movement of the engine-piston as follows: Keyed to the shaft 39 is a grooved wheel having a round concentric part 70 and an oval eccentric part 71. Formed in the peripheries of the parts 70 and 71 is a groove

72, continuous throughout the peripheries of the parts 70 and 71 and passing completely around said parts three times. A pivoted rod has one end inserted in said groove, as will hereinafter appear, and this rod is moved away from the shaft 39 once during each third rotation of the parts 70 and 71—that is to say, when the rod is traversing the groove in the part 71 it is moved outwardly from the shaft during part of this revolution, and when the rod is traversing the groove in the part 70 it does not move outwardly.

The reference-numeral 73 indicates a bracket fixed to a part of the engine-frame and having a slot 74 in its outer end. Slidingly mounted in this slot 74 is a block 75, through which a rod 76 passes and is capable of sliding longitudinally. The one end of the rod 76 is inserted in the groove 72, and on its other end is a block 77 to normally engage the block 68, which block is slidingly supported on the bracket 78. The rod 76 is normally held to its limit in a direction toward the part 71 by means of the spring 79. Obviously during the rotation of the wheel 70 and 71 the rod 76 will follow the groove 72, and the block 75 will slide in the groove 74, and the block 77 will slide longitudinally in the bracket 78, and the rod 76 will be moved outwardly from the wheel 70 and 71 once during each third revolution of said wheel, and, as before stated, the block 77 is normally in engagement with the block 68, and hence the valve 65 will be opened once during each third revolution of the wheels 70 and 71.

We have provided an automatic governor arranged to control the operations of the valve 65 in such manner that when the shaft reaches a certain predetermined speed the governor will operate to move the block 68 of the rod 64 out of the path of travel of the block 77 as follows: The numeral 80 indicates a grooved wheel slidingly but non-rotatably mounted upon the shaft 39. Adjacent to the grooved wheel 80 is a fly-wheel 81, keyed to the shaft 39, and an extensile spring 82 is mounted on shaft 39 between the wheels 80 and 81. Connected with the spokes of the wheel 81 are the bell-crank levers 83, each having one end in the groove of the wheel 80 and each having a ball 84 at its other end, the parts being so arranged that as the speed of rotation of the wheel 81 increases the balls are thrown outwardly by centrifugal force, and the grooved wheel 80 is moved against the pressure of the spring 82 toward the wheel 81, and as the speed of rotation diminishes the balls 84 are drawn inwardly against action of centrifugal force by the resiliency of spring 82. The numeral 85 indicates a bracket fixed to the engine-frame, and 86 indicates a lever fulcrumed to said bracket and having one end resting in the groove of the wheel 80 and its other end connected with the block 68.

We have provided means whereby the engine may be stopped by manipulation of the

lever as follows: The numeral 87 indicates a bracket fixed to the machine-frame and having a lever 88 fulcrumed in its outer end. This lever normally stands with its upper end inclined upwardly and toward the rear end of the machine, and a rod 89 connects the upper end of the machine with the block 68, the parts being so arranged that when the upper end of the lever 88 moves forwardly the rod 89 will force block 68 in a direction away from the lever 88. Fulcrumed to a suitable support is a lever 90, which lever is connected with lever 88 by means of the rod 91, so that the said lever 88 may be conveniently moved by the operator.

We have also provided means for locking the lever 90 in position as follows: The numeral 92 indicates a sector adjacent to the lever, and 93 indicates a pawl mounted in lever 90 to engage the sector. Under ordinary conditions we do not place the pawl 93 in engagement with the sector, but permit the lever 90 to move to and fro with the lever 86, which is actuated by the ball-governor; but obviously this lever 90 may be locked in position, and thereby the governor will be also locked in position and the operation of the engine stopped. In practical use with this part of the device the valve 65 is automatically opened by the wheels 70 and 71 and connected parts during each third cycle of the engine movement. When the speed of rotation of the shaft 39 becomes too great, the ball-governor automatically throws the block 68 out of the path of travel of the block 77, thus holding valve 65 closed, or the valve 65 may be manually held closed by a manipulation of lever 90.

In practical use and assuming that an explosion has just occurred the piston moves outwardly, and the pressure inside of chamber 44 keeps the valve 61 closed. When the piston returns, the exploded gas is forced through the opening 62 into chamber 44, and during this stroke the valve 65 is held open by the cam-wheel 71 and the exploded gas is discharged into the chamber 43 and through the exhaust-port 69. Upon the second outward stroke of the piston the valve 65 closes and a vacuum is formed in the chamber 44, which causes the valve 61 to open and admit the gas from the mixing chamber. Upon the return piston-stroke the valve 61 is closed and the gas compressed in the engine-cylinder and in the chamber 44. During the third outward stroke of the piston more gas is drawn into the engine-cylinder in the same way and all of the gas is thoroughly commingled, so that upon the final compression-stroke of the piston the gas is in condition for an effective explosion and is ignited in the ordinary manner.

Having thus described our invention, what we claim, and desire to secure by Letters Patent of the United States therefor, is—

1. The combination with a hydrocarbon-engine, of a cylinder communicating with the

interior of the engine and having inlet and discharge openings, a spring-actuated valve for controlling the inlet-opening to be opened by suction within the cylinder, a mixing-chamber communicating with the cylinder through the said inlet-opening, a valve 65 controlling the discharge-opening, a valve-stem 64 connected therewith, a block 68 on the end of the valve-stem, a spring 67 normally holding the valve in its closed position, a wheel comprising the round portions 70 and the elliptical portion 71 having a continuous groove 72 on their peripheries, a slotted bracket 73, a sliding block 75 mounted for movement on the slotted bracket, a rod 76 slidably mounted in the block 75 and having one end in the groove 72, a spring for normally holding the rod in the groove, a block 77 on the opposite end of the rod, and a bracket 78 for slidably supporting the block 77, said parts being so arranged that during each third revolution of the grooved wheel the valve 65 will be opened.

2. The combination with a hydrocarbon-engine, of a cylinder communicating with the interior of the engine and having inlet and discharge openings, a spring-actuated valve for controlling the inlet-opening to be opened by suction within the cylinder, a mixing-chamber communicating with the cylinder through the said inlet-opening, a valve 65 controlling the discharge-opening, a valve-stem 64 connected therewith, a hinge 66 in said valve-stem, a block 68 on the end of the valve-stem, a spring 67 normally holding the valve in its closed position, a wheel comprising the round portions 70 and the elliptical portion 71 having a continuous groove 72 on their peripheries, a slotted bracket, a rod 76 slidably mounted in the bracket and having one end in the groove 72, a spring for normally holding the rod in the groove, a block 77 on the opposite end of the rod, and a bracket 78 for slidably supporting the block 77, said parts being so arranged that during each third revolution of the grooved wheel the valve 65 will be opened, and a centrifugal ball-governor connected with the block 68 on the valve-stem 64 whereby the block 68 is moved laterally out of the path of travel of the block 77 when a certain predetermined speed has been attained.

3. The combination with a hydrocarbon-engine, of a cylinder communicating with the interior of the engine and having inlet and discharge openings, a spring-actuated valve for controlling the inlet-opening to be opened by suction within the cylinder, a mixing-chamber communicating with the cylinder through the said inlet-opening, a valve 65 controlling the discharge-opening, a valve-stem 64 connected therewith, a hinge 66 in said valve-stem, a block 68 on the end of the valve-stem, a spring 67 normally holding the valve in its closed position, a wheel comprising the round portions 70 and the elliptical portion 71 having a continuous groove 72 on

their peripheries, a slotted bracket, a rod 76  
 slidingly mounted in the bracket and having  
 one end in the groove 72, a spring for nor-  
 mally holding the rod in the groove, a block  
 5 77 on the opposite end of the rod, and a  
 bracket 78 for slidingly supporting the block  
 77, said parts being so arranged that during  
 each third revolution of the grooved wheel  
 the valve 65 will be opened, a fly-wheel 81 on  
 10 the same shaft to which the wheel 70 and 71  
 is fixed, levers pivoted to said wheel and hav-  
 ing weighted balls at one end to move radi-  
 ally as the speed of the wheel increases or di-  
 minishes, a grooved wheel slidingly but non-  
 15 rotatably mounted on the same shaft and hav-  
 ing the said lever inserted in its groove, a  
 spring for normally holding the grooved  
 wheel to one limit of its movement, and a  
 pivoted lever having one end in the groove  
 20 of said wheel and its other end connected with  
 the block 68 of the valve-stem 64.

4. The combination with a hydrocarbon-en-  
 gine, of a cylinder communicating with the  
 interior of the engine and having inlet and  
 25 discharge openings, a spring-actuated valve  
 for controlling the inlet-opening to be opened  
 by suction within the cylinder, a mixing-  
 chamber communicating with the cylinder  
 through the said inlet-opening, a valve 65  
 30 controlling the discharge-opening, a valve-  
 stem 64 connected therewith, a hinge 66 in

said valve-stem, a block 68 on the end of the  
 valve-stem, a spring 67 normally holding the  
 valve in its closed position, a wheel compris-  
 ing the round portions 70 and the elliptical  
 35 portion 71 having a continuous groove 72 on  
 their peripheries, a slotted bracket, a rod 76  
 slidingly mounted in the bracket and having  
 one end in the groove 72, a spring for normally  
 holding the rod in the groove, a block 77 on  
 40 the opposite end of the rod, and a bracket 78  
 for slidingly supporting the block 77, said  
 parts being so arranged that during each third  
 revolution of the grooved wheel the valve 65  
 will be opened, a fly-wheel 81 on the same  
 45 shaft to which the wheel 70 and 71 is fixed, le-  
 vers pivoted to said wheel and having weight-  
 ed balls at one end to move radially as the  
 speed of the wheel increases or diminishes, a  
 grooved wheel slidingly but non-rotatably  
 50 mounted on the same shaft and having the  
 said lever inserted in its groove, a spring for  
 normally holding the grooved wheel to one  
 limit of its movement, and a pivoted lever  
 having one end in the groove of said wheel  
 55 and its other end connected with the block  
 68 of the valve-stem 64.

FREDERICK A. KLOCKSIEM.

HENRY F. KLOCKSIEM.

Witnesses:

MONE KLOCKSIEM,

WILLIAM H. STIEGELMEYER.