

(19)



Europäisches Patentamt
European Patent Office
Office européen des brevets



(11)

EP 0 625 231 B1

(12)

EUROPEAN PATENT SPECIFICATION

(45) Date of publication and mention
of the grant of the patent:
20.10.1999 Bulletin 1999/42

(51) Int Cl.⁶: **E04B 1/74**
// E04B1/92, E04C2/20

(21) Application number: **93904434.3**

(86) International application number:
PCT/SE93/00090

(22) Date of filing: **05.02.1993**

(87) International publication number:
WO 93/16243 (19.08.1993 Gazette 1993/20)

(54) **A JOINT DEVICE**

FUGENVORRICHTUNG

DISPOSITIF D'UN JOINT

(84) Designated Contracting States:
DE FR GB SE

(74) Representative: **Bjerkén, Jarl Hakan**
Bjerkéns Patentbyrå KB
P.O.Box 1274
801 37 Gävle (SE)

(30) Priority: **07.02.1992 SE 9200361**

(43) Date of publication of application:
23.11.1994 Bulletin 1994/47

(56) References cited:
EP-A- 0 257 016 **DE-A- 2 159 042**
DE-A- 3 043 745 **FR-A- 2 345 560**
SE-A- 8 705 188 **SE-B- 431 356**
SE-B- 433 372 **US-A- 4 776 142**

(73) Proprietor: **WILJE, Oscar**
S-791 23 Falun (SE)

(72) Inventor: **WILJE, Oscar**
S-791 23 Falun (SE)

EP 0 625 231 B1

Note: Within nine months from the publication of the mention of the grant of the European patent, any person may give notice to the European Patent Office of opposition to the European patent granted. Notice of opposition shall be filed in a written reasoned statement. It shall not be deemed to have been filed until the opposition fee has been paid. (Art. 99(1) European Patent Convention).

Description

FIELD OF THE INVENTION AND PRIOR ART

[0001] The present invention relates to a joint device comprising two sheet-like building elements made for insulating purposes, wherein element portions of both elements extending along the joint border are designed to be brought into engagement with each other and to create a connection between said two elements at the joint by means of a male member comprising a rib extending along the longitudinal direction of the joint and a female member comprising a groove extending along the longitudinal direction of the joint, the convergence of the male member substantially corresponding to the divergence of the female member, wherein the male member is adapted to be freely introducible into the female member until it reaches an introduced position in which substantially the entire surfaces of the lateral wall portions thereof introduced into the female member bear against wall portions of the female member, the dimensions of the male and female members being so chosen with respect to each other that the end surfaces of the rib are located at a certain distance from the bottom of the groove in said introduced position.

[0002] Such building elements may be used for insulating a building or parts thereof against for instance moisture or radon and so as to reduce the heat exchange between the interior of the building and the surroundings. The present invention generally relates to all conceivable uses of building elements for insulating purposes and in particular those for protecting the foundation of a building against moisture and radon gas from the surrounding ground, for which reason the latter case will be discussed hereinafter in exemplifying but not limiting way.

[0003] When insulating the foundation of buildings it was conventional practice to lay insulating sheets loose close to each other in several layers before the foundation plate of the building was casted or moulded thereupon or close to each other in the mould for moulding basement walls or under the floor structure or on the basement wall of buildings already existing. The disadvantage of these procedures is that a joint between the adjacent building elements does not become completely tight, but the elements will slide slightly apart at least some locations. It is even sufficient with very small gaps, which may appear when elements are actually bearing against each other as a consequence of small irregularities in their bearing surfaces, for letting moisture and radon gas find a way through the insulation and reach the interior of the building with a risk of moisture damages on the floor covering or the wall covering and the formation of mould and radon daughters detrimental to the health. The latter are particularly "nasty", since the radioactive radiation emitted therefrom has turned out to be strongly likely to cause lung cancer.

[0004] SE-B-0 433 372 illustrates a joint device ac-

ording to the pre-characterising part of claim 1. Although this joint device comprises cooperating male and female members, a deficiency with this known joint device is that it is difficult to achieve excellent tightness. This is also due for the joint device disclosed in FR-A-2 345 560.

SUMMARY OF THE INVENTION

[0005] The object of the present invention is to provide a device of the type defined in the introduction, which to a great extent reduces the disadvantages mentioned above and the inconveniences appearing at the level of the joints between building elements of the type in question.

[0006] This object is according to the invention obtained by a device according to the appended claim 1. Thanks to the construction of the element portions of both elements a tight connection between the two adjacent building elements may be achieved at the joint, so that this joint does not constitute any place in which moisture, radon gas or the like may come through the insulation in an easier way than by choosing a way through the very elements.

[0007] The device according to the invention of course also results in advantages in heat insulation, since it is precluded that an increased flow of heat away takes place at the joint, and a heat insulation having such joints may be especially suitable in an internal supplementary insulating of a house built by blue light-concrete, since this material emits unacceptable amounts of radon gas.

[0008] At least the surfaces of both elements adapted to form the joint therebetween as well as the sheet plane surfaces located on one side of the elements are according to a preferred embodiment of the invention covered by aluminium foil for reflecting especially radon gas. A joint having an even better possibility to keep the harmful radon gas outside the building is obtained in this way.

[0009] According to a further embodiment, the building element having a sheet-like body is provided with one or more air channels extending therein between the sheet planes and therealong and means are provided for connecting the air channels to means for generating a negative air pressure therein so as to conduct substances, such as radon gas, entering into the element away therethrough and prevent them from passing through the element. By designing a building element for insulating purposes in this way especially radon gas, but also moisture and undesired substances which despite all manage to penetrate into the building element, may be sucked away before they reach the other side of the element and they are preferably emitted to the ambient atmosphere.

[0010] According to another embodiment, the building element having a body of insulating material is provided with small aluminium foil pieces distributed therein. It

has turned out that such a building element is very efficient in reflecting radon gas. This ability is not reduced with increasing age of the building element and such a building element may be easily handled without any risk of appearance of damages deteriorating this ability, since the aluminium foil pieces of crucial importance for this ability are embedded in the body of insulating material.

[0011] Further advantages and advantageous characteristics of the invention appear from the following description and the other dependent claims.

BRIEF DESCRIPTION OF THE DRAWINGS

[0012] With reference to the appended drawings, below follows a specific description of preferred embodiments of the invention cited as examples.

[0013] In the drawings:

Fig 1 is a perspective view of building elements designed to obtain a device in a joint in accordance with a preferred embodiment of the invention,

Fig 2 is a sideview of a device in a joint between two building elements according to a preferred embodiment of the invention with the elements in a not jointly interconnected position,

Fig 3 is a view corresponding to Fig 2 with the elements in a jointly interconnected position, and

Fig 4 and 5 are views corresponding to Fig 2 and 3, respectively, of two building elements jointly interconnected and having another construction according to the invention.

DETAILED DESCRIPTION OF PREFERRED EMBODIMENTS OF THE INVENTION

[0014] Some sheet-like building elements 1 for insulating purposes and having a device in a joint according to the present invention are shown in Fig 1. It appears that the definition sheet-like is to be interpreted in its broadest meaning, i.e. it does only state that it is a question of an element having two opposite surfaces being substantially parallel to each other, so called sheet plane surfaces. The elements consist preferably of moulded foamed plastic, which has a very low density and a good heat insulating capacity.

[0015] The building elements are made in one piece and have a rebat-like configuration 2 along the borders intended to be jointly connected to other similar building elements, said configuration having a rib 4 extending along said border and having its free upper end surfaces 3 directed substantially perpendicularly to the sheet planes and a groove 5 extending parallelly thereto and delimited by the rib on one side.

[0016] Reference is now also made to Fig 2 and 3.

The lateral walls 6 of the rib 4 converge in the direction towards the free end surfaces 3 thereof, and the lateral walls 7 of the groove 5 diverge from the bottom 8 of the groove by a degree of divergence substantially corresponding to the degree of convergence of the rib 4. Furthermore, the width of the bottom of the groove 5, the thickness of the rib as well as the height of the rib as seen from the bottom of the groove are so dimensioned, that a rib and a groove identically dimensioned of another building element may be brought into engagement therewith while introducing the respective rib into the respective groove until reaching a position in which substantially the entire surfaces of the lateral wall portions of the ribs introduced into the grooves bear against lateral wall portions of the respective groove. Furthermore, the height of these dimensions are so chosen that the end surfaces 3 of the rib 4 are located at a certain distance from the bottom of the groove 5 in said position. Since the building elements are made of foamed plastic, which may be slightly deformed, the respective rib may after reaching said position be pressed in a little bit further into the respective groove while deforming the ribs and adjacent element portions, so that a tightening wedge action is obtained in said joint by the fact that it stores potential energy pressing the surfaces of the ribs and the grooves bearing against each other tightly against each other. The sheet plane surfaces on either side of the joint are intended to be located in substantially the same plane after this further pressing inwardly.

[0017] Thus, the joining of the two elements 1, 1' takes place by moving the rebat-like configurations 2 thereof into engagement with each other by a relative movement thereof substantially perpendicularly to their sheet planes from the position according to Fig 2 to that according to Fig 3. Furthermore, the two elements 1, 1' shown in Fig 2 and 3 are covered by aluminium foil 9 on the sheet plane surfaces located on one side, said foil continuing over the rib and groove in question to the opposite sheet plane surfaces. Since the aluminium foil is comparatively sensitive and may easily be torn apart, it is preferably covered by a diffusion tight plastic paste so as to obtain a higher mechanical strength. The definition that the surfaces are covered by aluminium foil made in the claims is intended to comprise the case that this aluminium foil has a coating, so that the aluminium foil in the practice does not constitute the very surface layer of said surfaces. In this way it is obtained in the position according to Fig 3 that the two insulating elements in the region of the joint therebetween function as if they were one single continuous insulating element having one side covered by aluminium foil, while there is also aluminium foil absorbing and reflecting moisture, radon gas and the like which with a low probability will enter into said joint.

[0018] By arranging the two element 1, 1' to overlap each other by their rebat configurations in the direction perpendicular to the sheet plane of the elements, so that the joint line 10 between the elements on one side there-

of is displaced with respect to the joint line 11 on the other side, a higher protection against penetration of such undesired substances in the very joint is obtained.

[0019] It is shown in Fig 1 how the rebat-like configuration 2 is arranged on some of the sides of the insulating elements, which however only is made for the sake of simplicity, and it would in the practice be most advantageous to arrange the rebat-like configuration around the entire building elements, and it would then be possible to cut off that building element which will be located outermost in carrying out the insulating. The rebat configuration on the opposite sides of one and the same building element are then preferably directed with the ribs and the groove bottoms in the opposite directions with respect to each other, so that the insulation may be assembled by applying an element for instance on a wall surface, introducing a rib of an adjacent element into a groove of the first element, than introducing a rib of a third element into a groove of the second element and so on by relative movements of the elements with respect to each other substantially in the direction perpendicular to said wall. It is shown in Fig 1 how two building elements 1, 1' designed for a joint interconnection have a rib 4" and a groove 5" each also along an end border 31 extending substantially perpendicularly to the joint border. A material saving 32 substantially corresponding to the total width of the rib and the groove in the two dimensions of the sheet planes is carried out in the region in which the joint border and the end border meet in the one element 1, while the rib 4" and the groove 5" of the end border of the other element 1' continue to the joint border. It is in this way achieved that a relative displacement of the two elements 1, 1' along the joint border in the form of a displacement of said one element 1 towards said end border of the other element 1' may only take place until the joint rib 4 of the element 1 comes to bear by means the front surface 33 thereof against the end rib 4" of the other element 1'. This feature facilitates a process for assembling the elements. Typical dimensions of standardized such elements may be: width 600 mm, length 1200 mm and thickness 50 mm.

[0020] Building elements 26 according to a further embodiment of the invention are schematically illustrated in Fig 4 and 5, which in the case shown have a device in joints of the kind shown in Fig 1-3 and they are for the rest provided with one or more air channels 27 extending between the sheet planes and therealong, said channels being created by laying perforated plastic tubes 28 in the elements 26 when moulding them. It is possible to provide the elements with an amount of air channels in this way which preferably are interconnected on any place, for example by transversal channels extending between channels extending parallelly to each other. The air channels are so arranged that they in jointly interconnecting two building elements 26 will come into mutual alignment for communication therebetween. These air channels are intended to be connected to means indicated in Fig 5 by a fan symbol 29 for gen-

erating a negative air pressure in the channels, so that substances, such as moisture and radon gas, entering thereto will be sucked away from the insulation through the air channels and preferably be emitted to the ambient atmosphere. The negative air pressure may be created by fan means, but it is also possible that it is provided solely by connecting the air channels to the draught air channels of the building. As indicated in Fig 4 and 5, a coating of the building elements with aluminium foil 9 may also be carried out here so as to make these even more unwilling to let radon gas through, and it is also possible to improve this feature further by providing also these elements with aluminium foil pieces embedded in the insulating bodies in the way described above.

[0021] The invention is of course not in any way restricted to the preferred embodiments described above, but several possibilities to modifications thereof would be apparent to a man skilled in the art without departing from the scope of the appended claims.

[0022] It would for instance be possible to produce the building elements of any other material than indicated above and construct the engaging means in another way as long as the described function is maintained.

[0023] It is also conceivable to provide the building element with more than one rib and groove at one and the same border, so that for instance a series of thin ribs and narrow grooves being substantially mutually parallel could be arranged along a border for engaging into corresponding means of an adjacent element.

[0024] It would also be possible to alternately arrange ribs and grooves along a border of the element and extending substantially perpendicularly to the sheet plane surfaces, so that the free end surfaces of the ribs and the bottom of the grooves are directed substantially parallelly to the sheet plane surfaces. The elements could then be intended to be brought into engagement with each other by a relative movement thereof substantially perpendicularly to their sheet planes by the fact that the ribs converge and the grooves diverge in substantially corresponding degree in the direction substantially perpendicular to the sheet plane surfaces and accordingly in the longitudinal directions thereof. The short sides of the ribs are here also to be considered as the free ends thereof.

Claims

1. A joint device comprising two sheet-like building elements (1, 1') made for insulating purposes, wherein element portions (2) of both elements extending along the joint border are designed to be brought into engagement with each other and to create a connection between said two elements at the joint by means of male member comprising a rib (4) extending along the longitudinal direction of the joint and a female member comprising a groove (5) ex-

tending along the longitudinal direction of the joint, the convergence of the male member (4) substantially corresponding to the divergence of the female member (5), wherein the male member is adapted to be freely introducible into the female member until it reaches an introduced position in which substantially the entire surfaces of the lateral wall portions (6, 7) thereof introduced into the female member bear against wall portions (7) of the female member, the dimensions of the male (4) and female (5) members being so chosen with respect to each other that the end surfaces of the rib are located at a certain distance from the bottom of the groove in said introduced position, **characterized** in that the respective rib is adapted to be pressed a small distance further into the respective groove, starting from said introduced position, while deforming the rib and adjacent element portions so that a tightening wedge action is obtained, the sheet surfaces on either side of the joint being arranged to be located in substantially the same plane after this further inward pressing, and in that the male and female members of the element portions are designed to be brought into engagement with each other by a relative movement thereof substantially perpendicular to the sheet planes of both building elements (1, 1').

2. A device according to claim 1, **characterized** in that both element portions (2) have a male as well as a female member in the form of a rib (4) and a groove (5) having a lateral wall in common.
3. A device according to claim 2, **characterized** in that both elements (1, 1') have a rib (4") and a groove (5") each also along at least one end border (31) extending substantially perpendicularly to the joint border, and that a material saving (32) corresponding to substantially the total width of the rib and the groove in the two sheet plane dimensions is made in the region in which the joint border and the end border meet in one element (1), while the rib (4") and the groove (5") of the end border of the other element (1') continue to the joint border, so that a relative movement of the elements along the joint in the form of a displacement of said one element (1) towards said end border of the other element (1') is restricted by the fact that the joint rib (4) of said one element (1) comes to bear against the end rib (4") of the other element (1').
4. A device according to any of the preceding claims, **characterized** in that both element portions (2) are arranged to overlap each other in the direction perpendicular to the sheet plane of the elements in the engagement state, so that the joint line (10) between the elements on one side thereof is displaced

with respect to the joint line (11) on the other side.

5. A device according to any of the preceding claims, **characterized** in that at least the surfaces (6, 7) of the two elements (1, 1') which are adapted to form a joint therebetween as well as the sheet plane surfaces located on one side of the elements are covered by aluminium foil (9) for reflecting especially radon gas.
6. A device according to any preceding claim, **characterized** in that the building elements comprise a body of insulating material having small aluminium foil pieces (25) in particular arranged to reflect radon gas embedded and distributed therein.
7. A device according to any preceding claim, **characterized** in that the building elements comprise a sheet-like body having one or more air channels (27) extending therein between the sheet planes and therealong and adapted to be connected to means (29) for generating a negative air pressure therein so as to conduct away, through these air channels, substances, such as radon gas, entering into the element (26) and prevent the substances from passing through the element.
8. A device according to claim 7, **characterized** in that the body of the building elements is made of hard foamed plastic having perforated tubes (28) moulded in therein and arranged to form said air channels (27).
9. A device according to claim 7 or 8, **characterized** in that said air channels (27) of a first building element are adapted to be brought into alignment with and be connected to such air channels in adjacent second building elements for creation of a system of air channels having a negative pressure in an insulating arrangement, comprising said building elements.

Patentansprüche

1. Fugenvorrichtung, umfassend zwei plattenförmige Bauelemente (1, 1') für Isolierzwecke, bei der Elementabschnitte (2) von beiden Elementen, welche sich entlang der Fugengrenze erstrecken, derart konstruiert sind, daß sie in Eingriff miteinander gebracht werden können und daß eine Verbindung zwischen den beiden Elementen an der Fuge mittels eines vorstehenden Baugliedes, welches eine Rippe (4) umfaßt, die sich in Längsrichtung der Fuge erstreckt, und eines hohlen Baugliedes, welches eine Nut (5) umfaßt, die sich in Längsrichtung der Fuge erstreckt, geschaffen werden kann, wobei die Konvergenz des vorstehenden Baugliedes (4) im

- wesentlichen der Divergenz des hohlen Baugliedes (5) entspricht, wobei das vorstehende Bauglied zum freien Einführen in das hohle Bauglied ausgebildet ist, bis es eine eingeführte Position erreicht, bei der im wesentlichen die gesamten Flächen seiner seitlichen Wandbereiche (6,7), die in das hohle Bauglied eingeführt sind, einen Druck gegen Wandbereiche (7) des hohlen Baugliedes ausüben, wobei die Dimensionen des vorstehenden (4) und des hohlen (5) Baugliedes relativ zueinander so gewählt sind, daß in dieser eingeführten Position die Endflächen der Rippe in einem bestimmten Abstand vom Boden der Nut angeordnet sind, dadurch gekennzeichnet, daß die betreffende Rippe so ausgebildet ist, daß sie, ausgehend von der genannten eingeführten Position, noch eine kleine Strecke weiter in die jeweilige Nut hineingepreßt werden kann, wobei die Rippe und die angrenzenden Elementabschnitte verformt werden, so daß eine abdichtende Keilwirkung erzielt wird, wobei die Plattenoberflächen an jeder Seite der Fuge so angeordnet sind, daß sie sich nach dem oben beschriebenen Hineinpressen im wesentlichen in der selben Ebene befinden, und daß die hervorstehenden und hohlen Bauglieder der Elementabschnitte so ausgebildet sind, daß sie miteinander durch eine Bewegung relativ zueinander im wesentlichen senkrecht zu den Plattenebenen beider Bauelemente (1, 1') in Eingriff gebracht werden.
2. Vorrichtung nach Anspruch 1, dadurch gekennzeichnet, daß beide Elementabschnitte (2) sowohl ein hervorstehendes als auch ein hohles Bauglied aufweisen, und zwar in Form einer Rippe (4) und einer Nut (5), die eine Seitenwand gemeinsam haben.
3. Vorrichtung nach Anspruch 2, dadurch gekennzeichnet, daß beide Elemente (1, 1') ebenfalls sowohl eine Rippe (4'') als auch eine Nut (5'') aufweisen, und zwar entlang wenigstens einer Endgrenze (31), die sich im wesentlichen senkrecht zur Fugengrenze erstreckt, und daß eine Materialaussparung (32), die in den beiden Dimensionen der Plattenebenen im wesentlichen der gesamten Breite der Rippe und der Nut entspricht, in dem Bereich ausgebildet ist, in dem die Fugengrenze und die Endgrenze in einem Element (1) zusammentreffen, während sich die Rippe (4'') und die Nut (5'') der Endgrenze des anderen Elementes (1') bis zu der Fugengrenze fortsetzen, so daß eine relative Bewegung der Elemente entlang der Fuge in Form einer Verschiebung des einen Elementes (1) in Richtung auf die Endgrenze des anderen Elementes (1') dadurch begrenzt wird, daß die Fugenrippe (4) des einen Elementes (1) schließlich gegen die Endrippe (4'') des anderen Elementes (1') anstößt.
4. Vorrichtung nach einem der vorhergehenden Ansprüche, dadurch gekennzeichnet, daß beide Elementabschnitte (2) so angeordnet sind, daß sie sich im Eingriffszustand in der zur Plattenebene der Elemente senkrechten Richtung überlappen, so daß die Fugenlinie (10) zwischen den Elementen auf einer Seite gegenüber der Fugenlinie (11) auf der anderen Seite versetzt ist.
5. Vorrichtung nach einem der vorhergehenden Ansprüche, dadurch gekennzeichnet, daß wenigstens die Oberflächen (6, 7) der beiden Elemente (1, 1'), die zur Bildung einer Fuge zwischen ihnen ausgebildet sind, wie auch die Flächen der Plattenebene, die sich auf einer Seite der Elemente befindet, mit Aluminiumfolie (9) zur Reflexion insbesondere von Radongas bedeckt sind.
6. Vorrichtung nach einem der vorhergehenden Ansprüche, dadurch gekennzeichnet, daß die Bauelemente einen Körper aus Isoliermaterial umfassen, der mit darin eingebetteten und verteilten kleinen Stückchen aus Aluminiumfolie (25) versehen ist, die insbesondere zur Reflexion von Radongas vorgesehen sind.
7. Vorrichtung nach einem der vorhergehenden Ansprüche, dadurch gekennzeichnet, daß die Bauelemente einen plattenartigen Körper umfassen, der einen oder mehrere Luftkanäle (27) aufweist, welche sich in dem Körper zwischen den Plattenebenen und entlang dieser Ebenen erstrecken und die zur Verbindung mit Mitteln (29) zur Erzeugung eines Luftunterdrucks in den Kanälen ausgebildet sind, um über diese Kanäle Substanzen, wie z.B. Radongas, die in das Element (26) eindringen, abzuleiten und zu verhindern, daß diese Substanzen durch das Element hindurchdringen.
8. Vorrichtung nach Anspruch 7, dadurch gekennzeichnet, daß der Körper der Bauelemente aus Hartschaumstoff besteht, der mit perforierten Röhren (28) versehen ist, welche darin eingeformt und so angeordnet sind, daß sie die Luftkanäle (27) bilden.
9. Vorrichtung nach Anspruch 7 oder 8, dadurch gekennzeichnet, daß die Luftkanäle (27) eines ersten Bauelementes so ausgebildet sind, daß sie mit Luftkanälen in angrenzenden, zweiten Bauelementen bündig ausgerichtet und mit diesen verbunden werden können, um in einer die Bauelemente umfassenden Isolieranordnung ein System von Luftkanälen mit Unterdruck zu schaffen.

Revendications

1. Dispositif de joint comprenant deux éléments de construction en forme de plaques (1, 1'), destinés à constituer des éléments d'isolation, dans lequel des parties (2) des deux éléments s'étendant le long du bord de jonction sont conçues pour être engagées l'une dans l'autre et pour créer une connexion entre ces deux éléments au niveau du joint, à l'aide d'un élément mâle comprenant une saillie (4) s'étendant le long du joint et un élément femelle comprenant une rainure (5) s'étendant le long du joint ; la proéminence de l'élément mâle (4) correspondant en grande partie au renforcement de l'élément femelle (5), étant entendu que l'élément mâle est adapté pour être librement introduit dans l'élément femelle jusqu'à obtention d'une position d'introduction dans laquelle presque toutes les surfaces des parties de la paroi latérale (6, 7) étant introduites dans l'élément femelle sont appuyées contre les parties de la paroi (7) de l'élément femelle ; les dimensions de l'élément mâle (4) et de l'élément femelle (5) sont choisies les unes par rapport aux autres de manière à ce que les surfaces du bord de la saillie soient situées à une certaine distance du bas de la rainure dans ladite position d'introduction ;
caractérisé en ce que la saillie est adaptée pour être enfoncée davantage dans la rainure correspondante, en partant de ladite position d'introduction, en déformant la saillie et les parties d'éléments adjacentes pour obtenir une action de blocage étanche, les surfaces des plaques des deux côtés du joint étant disposées de manière à être situées en grande partie dans un même plan après cette pression supplémentaire vers l'intérieur, **et en ce que** les éléments mâles et femelles des parties d'éléments sont conçus pour être engagés l'un dans l'autre par un mouvement relatif, perpendiculaire dans une large mesure aux plans des plaques des deux éléments de construction (1, 1').
2. Un dispositif conformément à la revendication 1, **caractérisé en ce que** les deux parties d'élément (2) disposent d'un élément mâle et d'un élément femelle sous forme d'une saillie (4) et d'une rainure (5) qui disposent d'une paroi latérale commune.
3. Un dispositif conformément à la revendication 2, **caractérisé en ce que** les deux éléments (1, 1') disposent d'une saillie (4") et d'une rainure (5"), chacune le long d'un bord d'extrémité au moins (31), s'étendant en grande partie dans un plan perpendiculaire au bord de jonction, **et en ce qu'un** espace matériel (32), correspondant substantiellement à la largeur totale de la saillie et de la rainure dans les dimensions planes des deux plaques, est ménagé dans la région où le bord de jonction et le bord de bout se rejoignent en un même élément (1) alors que la saillie (4") et la rainure (5") du bord extrême de l'autre élément (1') se poursuivent jusqu'au bord de jonction, de manière à ce qu'un mouvement relatif des éléments le long du joint, sous forme de déplacement de cet élément (1) en direction dudit bord extrême de l'autre élément (1'), soit restreint par le fait que la saillie de jonction (4) dudit élément (1) s'appuie contre la saillie de bout (4") de l'autre élément (1').
4. Un dispositif conformément à l'une des précédentes revendications
caractérisé en ce que les deux parties d'élément (2) sont disposées de manière à se chevaucher dans un sens perpendiculaire au plan de la plaque formée par l'engagement des éléments, pour que la ligne commune (10) entre les éléments sur l'un de leurs côtés soit décalée par rapport à la ligne commune (11) de l'autre côté.
5. Un dispositif conformément à l'une des précédentes revendications
caractérisé en ce qu'au moins les surfaces (6, 7) des deux éléments (1, 1') qui sont adaptés pour constituer un joint entre eux, ainsi que les surfaces planes de la plaque, situées sur un côté des éléments, sont couvertes d'une feuille d'aluminium (9) pour refléter notamment le radon.
6. Un dispositif conformément à l'une des précédentes revendications
caractérisé en ce que les éléments de construction comprennent un corps de matériau isolant comprenant de petites feuilles en aluminium (25) disposées notamment pour refléter le radon inclus et diffusé à l'intérieur.
7. Un dispositif conformément à l'une des précédentes revendications
caractérisé en ce que les éléments de construction comprennent un corps en forme de plaque, disposant d'un ou de plusieurs trous d'air (27) s'étendant à l'intérieur entre les plans des plaques et le long de celles-ci, adaptés pour être connectés à des moyens (29) permettant de générer une pression atmosphérique négative à l'intérieur et ce, afin d'évacuer au travers de ces trous d'air des substances, telles que le radon, pénétrant dans l'élément (26) et d'empêcher que les substances ne traversent l'élément.
8. Un dispositif conformément à la revendication 7
caractérisé en ce que le corps des éléments de construction est constitué par des mousses de plastique durcies dotées de tubes perforés (28) qui y sont moulés et disposés de manière à constituer les dits trous d'air (27).

9. Un dispositif conformément à la revendication 7 ou 8,

caractérisé en ce que lesdits trous d'air (27) du premier élément de construction sont adaptés pour être alignés et connectés aux trous d'air des deuxièmes éléments de construction adjacents, de manière à créer un système de trous d'air à pression négative dans un agencement isolant comprenant lesdits éléments de construction.

5

10

15

20

25

30

35

40

45

50

55

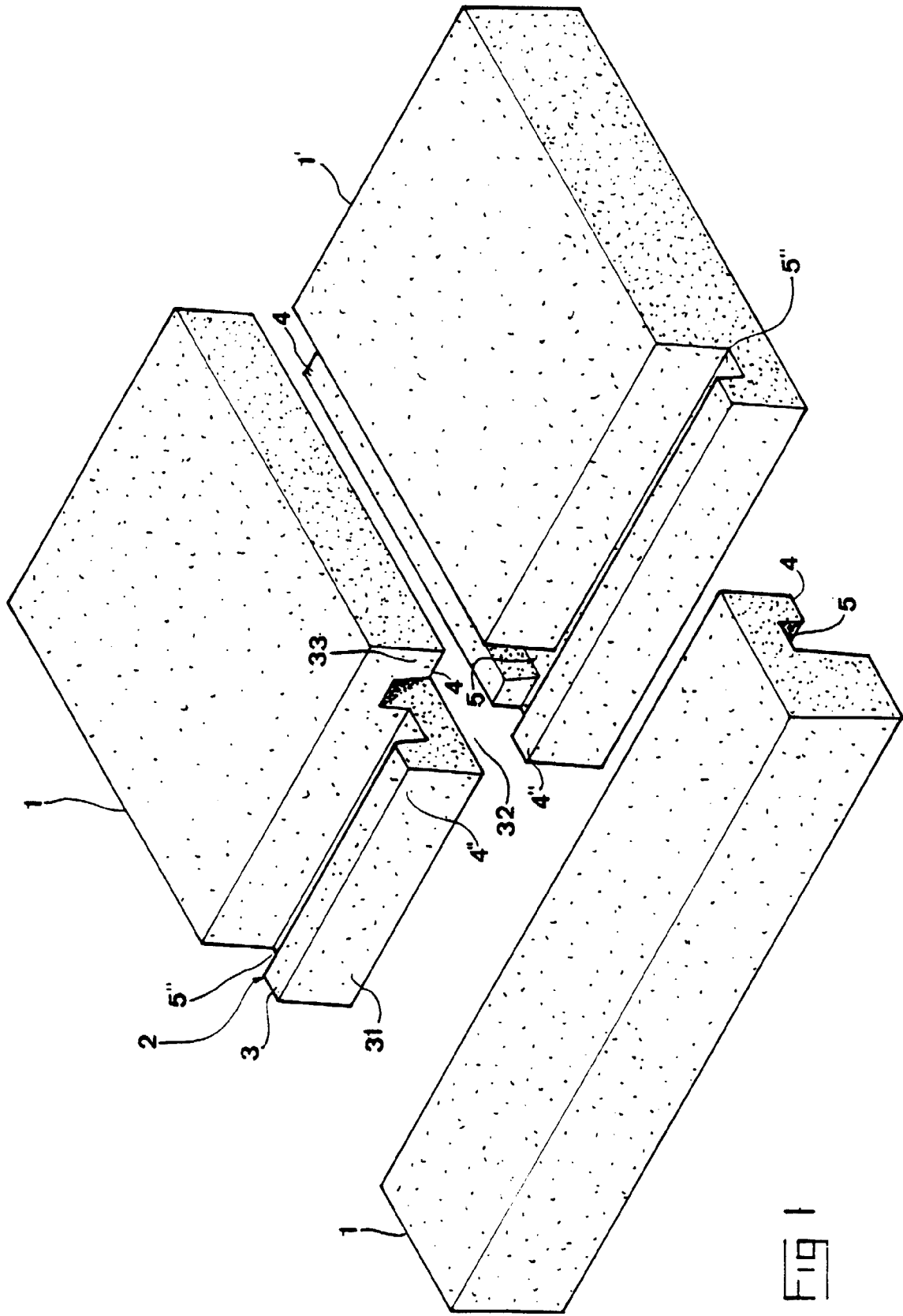

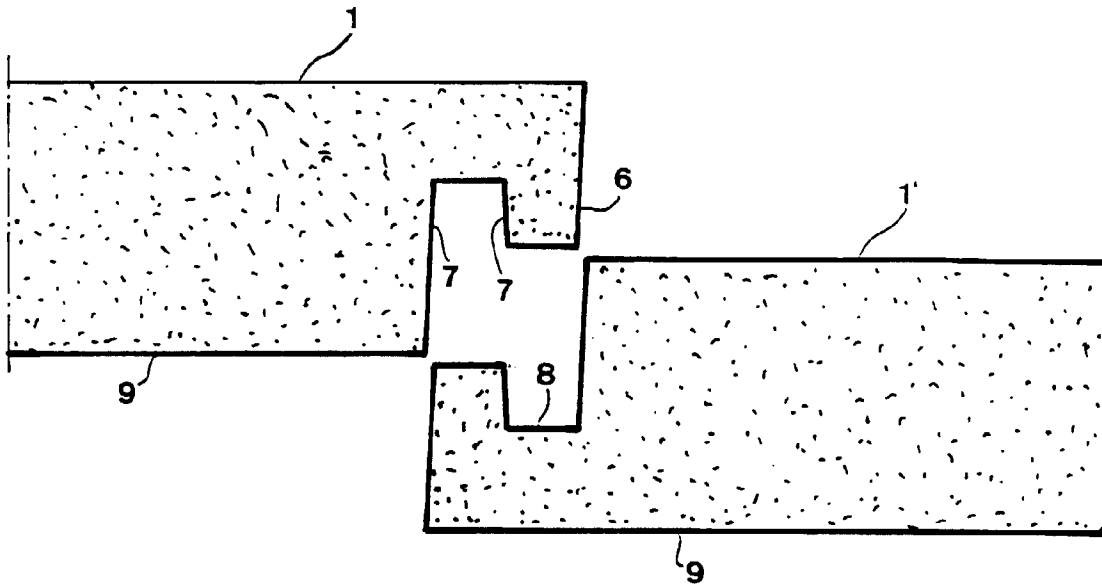

Fig 2

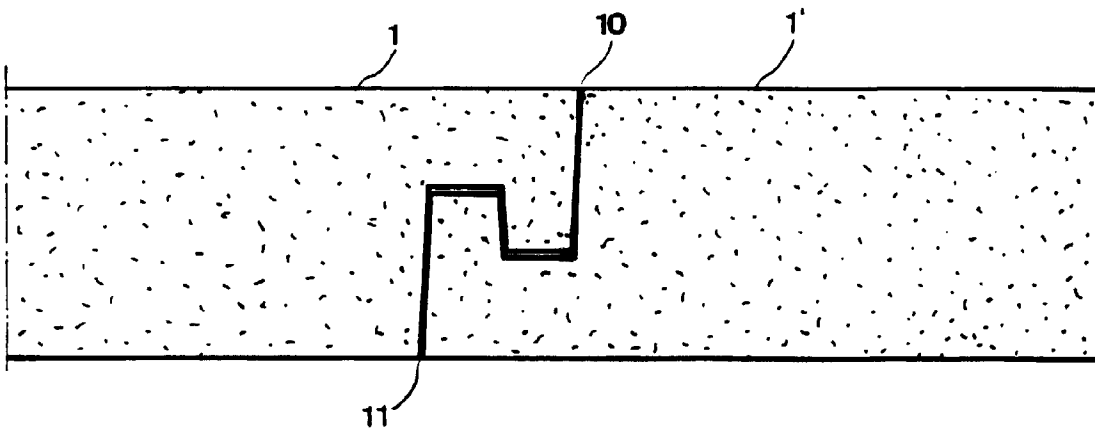

Fig 3

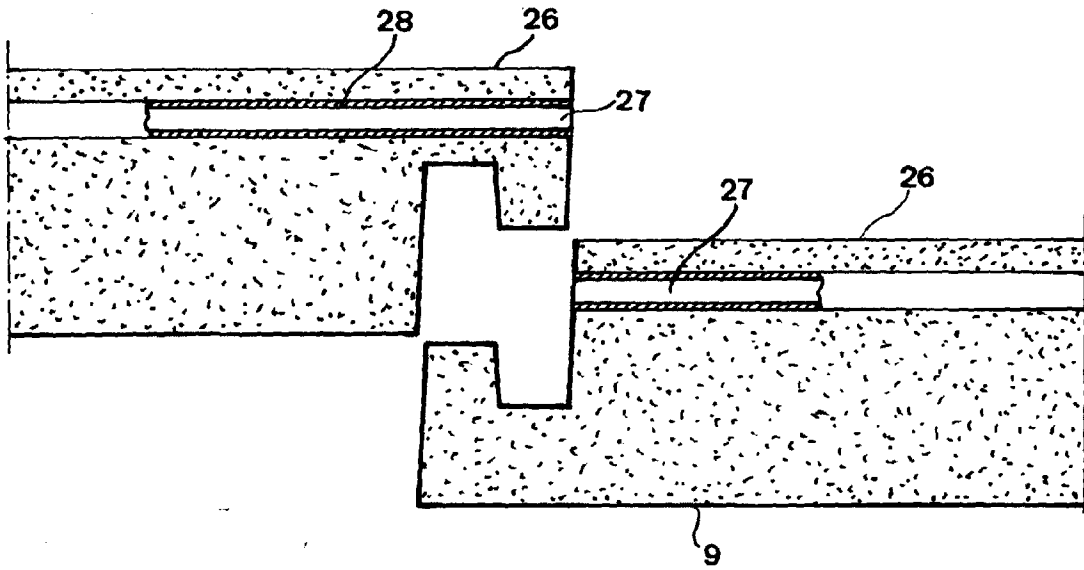

Fig 4

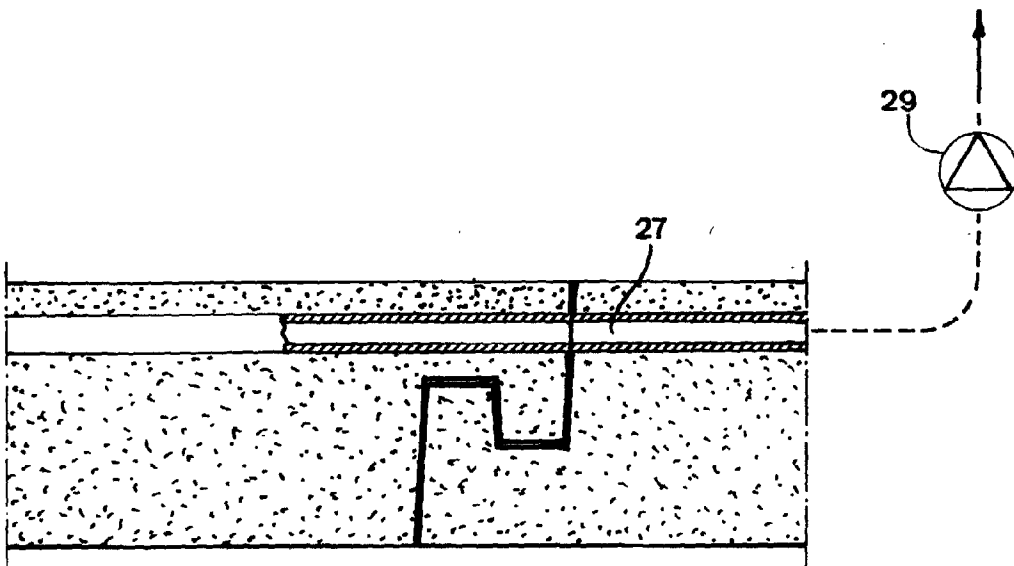

Fig 5