

996,778.

R. E. LIPPINCOTT.
CHANGEABLE ILLUMINATED SIGN.
APPLICATION FILED JULY 16, 1909.

Patented July 4, 1911.

4 SHEETS—SHEET 1.

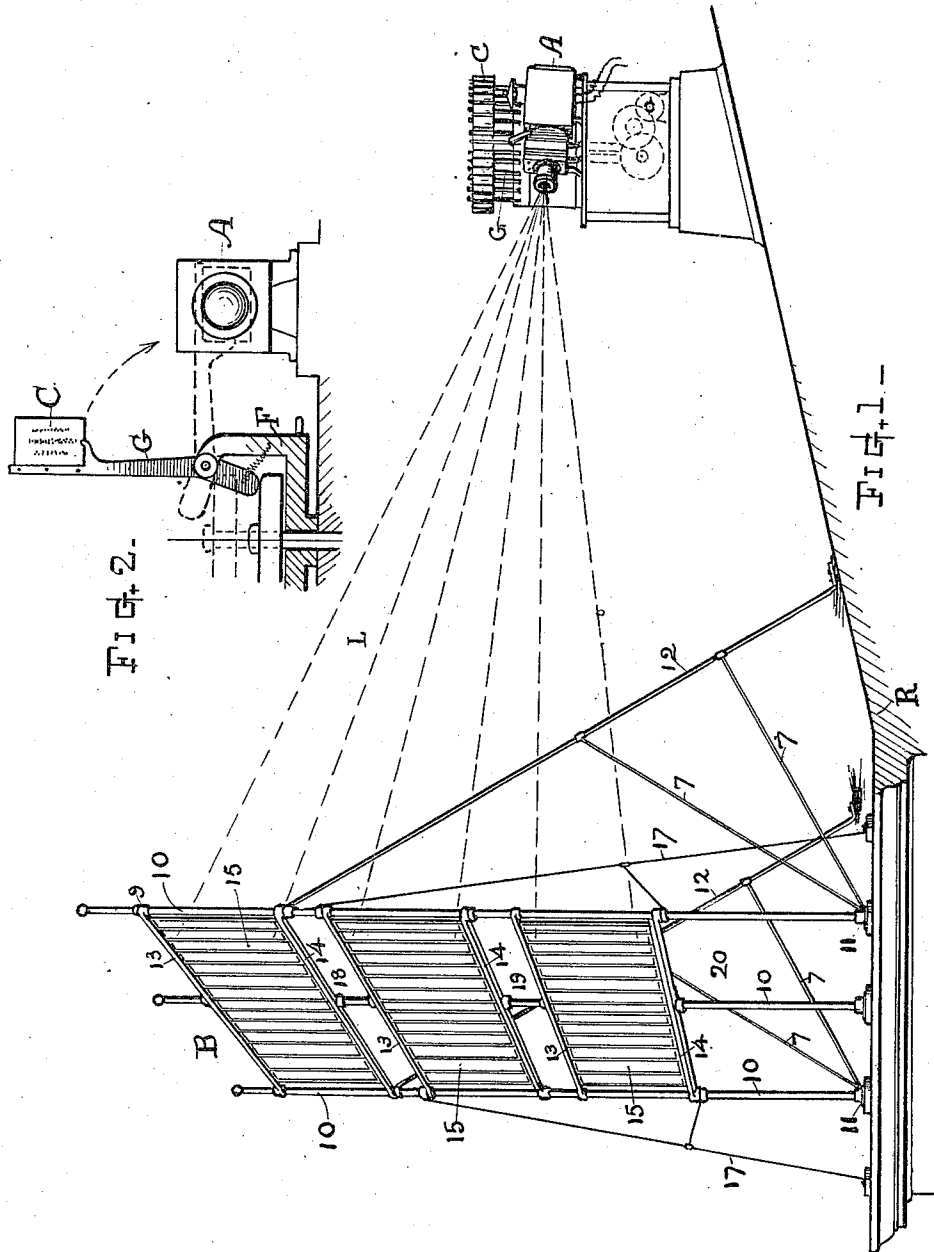

Witnesses—
Ralph Arey
Ella P. Blenus

Inventor—
Robert E. Lippincott
By Chas. H. Burleigh
Attorney

R. E. LIPPINCOTT.
 CHANGEABLE ILLUMINATED SIGN.
 APPLICATION FILED JULY 16, 1909.

996,778.

Patented July 4, 1911.

4 SHEETS—SHEET 2.

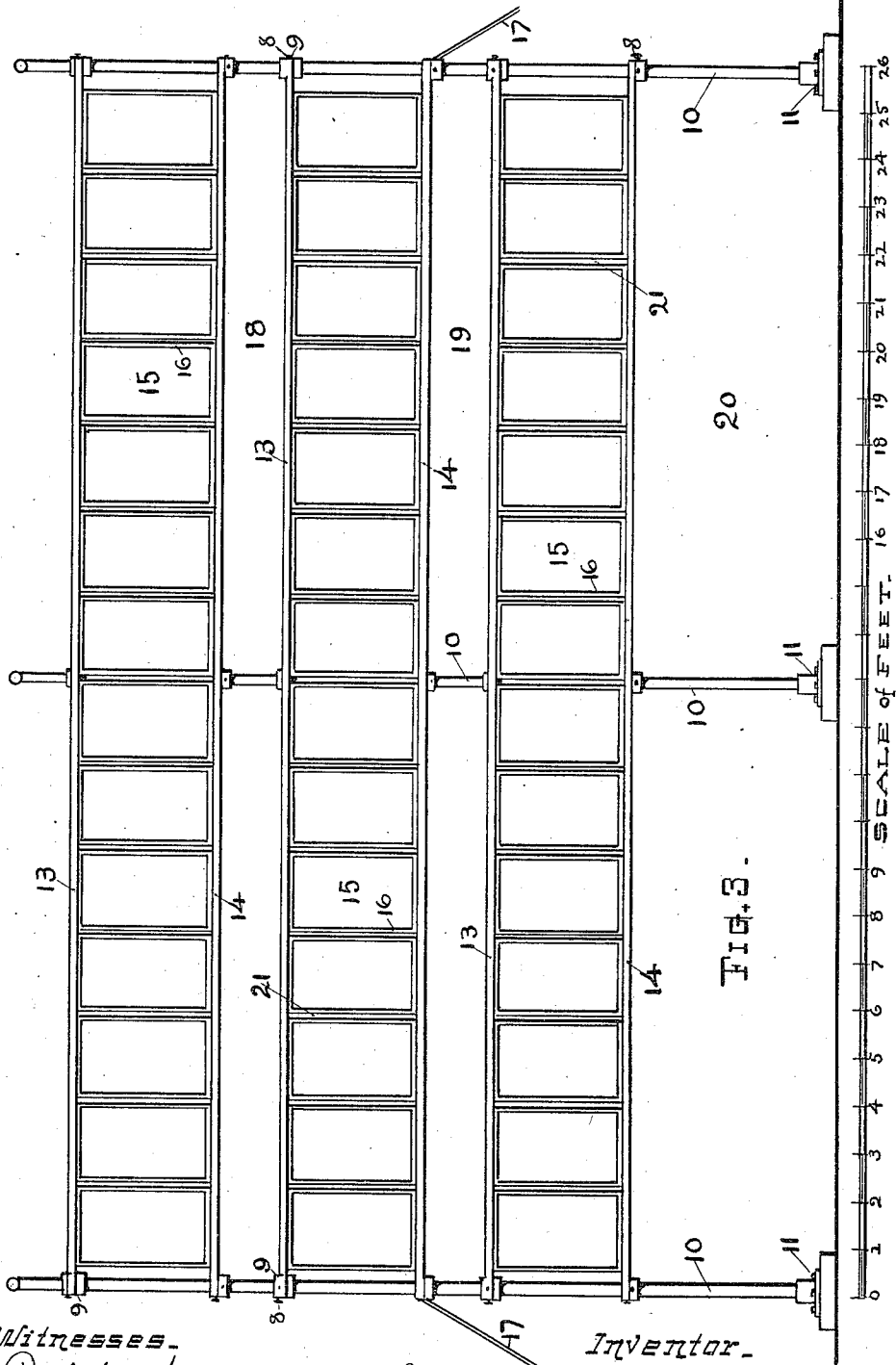

FIG. 3.

Witnesses.

Ralph Spry.
Ella P. Blenus

Inventor.

Robert E. Lippincott,
By Chas. H. Burlingame
Attorney.

996,778.

R. E. LIPPINCOTT.
CHANGEABLE ILLUMINATED SIGN.
APPLICATION FILED JULY 16, 1909.

Patented July 4, 1911.

4 SHEETS-SHEET 3.

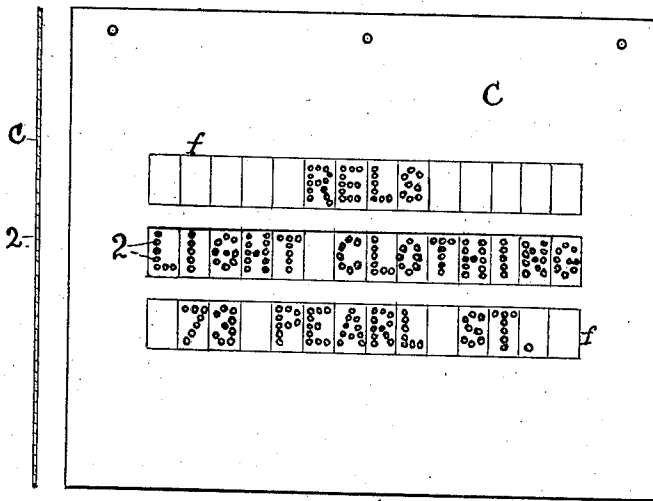

FIG. 4.

SCALE OF 0 1 2 3 4 INCHES.

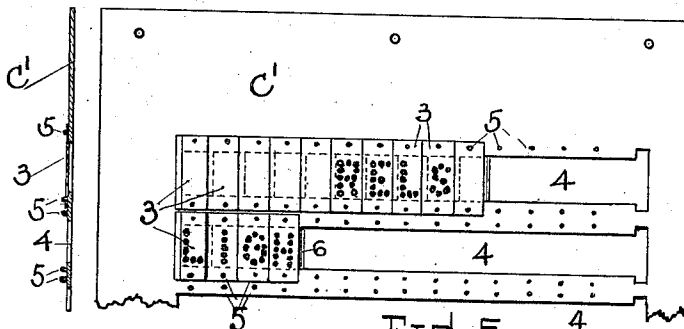

FIG. 5.

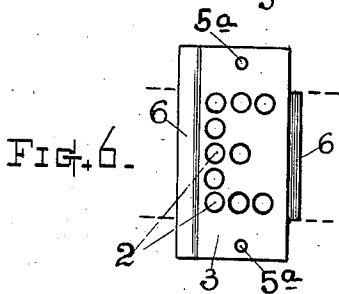

FIG. 6.

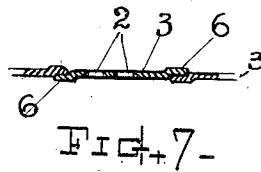

FIG. 7.

WITNESSES.
Ralph Arey.
Ella P. Blumer

INVENTOR.
Robert E. Lippincott.
By Chas. H. Burlingame
Attorney.

R. E. LIPPINCOTT.
 CHANGEABLE ILLUMINATED SIGN.
 APPLICATION FILED JULY 16, 1909.

996,778.

Patented July 4, 1911.

4 SHEETS—SHEET 4.

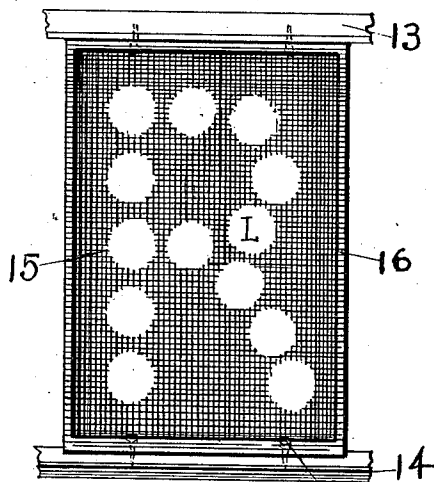

FIG. 8.

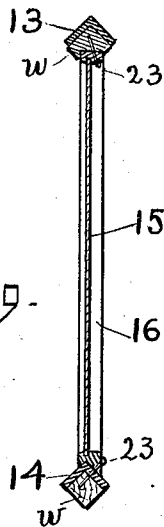

FIG. 9.

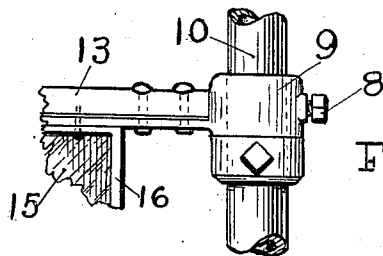

FIG. 10.

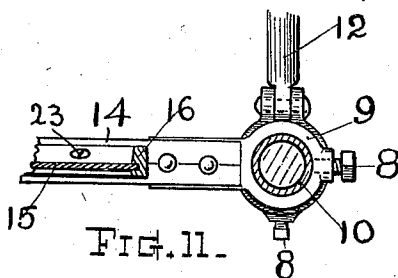

FIG. 11.

Witnesses.

Ralph Arrey.
 Ella P. Plenus.

Inventor.

Robert E. Lippincott
 By Chas. H. Burleigh
 Attorney.

UNITED STATES PATENT OFFICE.

ROBERT E. LIPPINCOTT, OF WORCESTER, MASSACHUSETTS, ASSIGNOR TO CHARLES H. BURLEIGH, OF WORCESTER, MASSACHUSETTS.

CHANGEABLE ILLUMINATED SIGN.

996,778.

Specification of Letters Patent.

Patented July 4, 1911.

Application filed July 16, 1909. Serial No. 508,047.

To all whom it may concern:

Be it known that I, ROBERT E. LIPPINCOTT, a citizen of the United States, residing at Worcester, in the county of Worcester and State of Massachusetts, have invented a new and useful Changeable Illuminated Sign, of which the following is a specification, reference being made therein to the accompanying drawings.

10 The prime object of my present invention is to provide a novel changeable illuminated advertising sign, adapted for erection upon the roof of a building, or in other exposed position, and adapted for showing a series of successively changing exhibits displayed in the manner substantially as set forth.

Another object is to provide a screen or exhibitory-field for the purpose stated, consisting of a plurality of individual translucent or semi-transparent panels or tablets, each adapted for the display thereon, by projected light, of a single letter, numeral, symbol or character; said panels or tablets being assembled in series, and preferably in rows with an open space between the rows.

Another object is to provide a changeable illuminated sign, comprising a system of individual translucent panels or tablets grouped and assembled in a predetermined order, and supported to form an extended screen or exhibitory-field, a light producing and intensifying means, and a sign-plate of a thin opaque material having letters, numerals, symbols or characters formed therein by perforations through the plate, the respective letters, numerals, symbols or characters being respectively arranged to conform to the order of arrangement of the individual translucent panels of the exhibitory-field, and for directing beams of light in the predetermined order of the panels.

The minor objects, structural organization and mode of operation of a mechanism embodying my invention will be understood from the following detailed description; the particular subject matter claimed being definitely set forth in the summary.

In the drawings, Figure 1 is a perspective view illustrating my invention as adapted for a roof display sign. Fig. 2 is a fragmentary view illustrating the manner of bringing the sign plates into the influence of the lighting means. Fig. 3 is a front elevation of my panel-sectioned exhibitory-

field or composite screen, as erected for use. Fig. 4 represents a front view (and section) of a sign-plate constructed in accordance with my invention. Fig. 5 illustrates, by front view and section, a modified form of sign-plate, having interchangeable individual letters, symbols or characters adapted to facilitate the "setting up" of different words or matter upon the same plate. Fig. 6 is an enlarged front view of one of the perforated letters or characters. Fig. 7 represents a horizontal cross section of the same. Fig. 8 is a separate front view of one of the translucent panels illustrating the characteristics of the illumination. Fig. 9 is a vertical section of one of the display panels and the girts supporting the same. Fig. 10 is a fragmentary elevation, and Fig. 11 a plan view showing in detail a means for joining the ends of the cross-girts to the upright standards.

As a feature of my invention I provide a composite or sectional exhibitory-field or screen for the changeable illuminations, which consists of a substantially upright structure comprising a row, or plurality of rows, of individually arranged tablets, panes or panels of translucent or semi-transparent material, disposed with ample space below and between the rows; each panel separately attached and individually adapted for the display thereon of a single letter, numeral, symbol or character by its interception of beams of light directed thereon, and changeable as the controlling means is shifted.

Referring to the drawings, A denotes a light-projecting instrument or magic-lantern apparatus; B the large standing exhibitory-field or screen practicable for erection upon the roof R of a building, or in other slightly situation, and upon which sign characters, corresponding with those delineated or prepared upon small peculiarly formed plates C, are luminously displayed and changed in the manner hereinafter set forth.

In carrying out my invention in practice I employ a projecting or optical lantern, including a source of intense light, such as a flaming-arc lamp, and lenses for concentrating, magnifying and directing the light upon the slides or exhibit plates which are preferably of the peculiar construction

hereinafter described. The plate C can in some instances be fed into the lantern by hand; but I prefer to use an automatic projection apparatus, similar in nature to that described in my prior application for Letters Patent Serial No. 373217 filed May 18, 1907, in which apparatus a series of plates C are carried upon a rotary supporter F by a series of arms G that are caused to swing the respective plates successively into and from alinement with the focal rays of the lantern, in a manner somewhat as indicated in Fig. 2; each succeeding plate being brought into display position and there remaining for a predetermined time, then automatically retracted and the next plate in its order thrown into display position.

As shown in Figs. 1 and 3 of the drawings, the structure of the screen B comprises the upright main standards 10, which are preferably made of metal tubing and each provided with a suitable attaching base or foot-piece 11. Upon these standards are one or more sets of horizontal girts 13 and 14, disposed upper and lower in pairs, and firmly attached to the uprights at their junctions, preferably by collars 9 and screws 8, or equivalent adjustable attaching means, (see Figs. 10 and 11) that will facilitate proper assemblage of the parts, and rigid fixation when assembled.

The girts or horizontal members 13 and 14 are best formed of angle-iron bars sufficiently strong to give the desired stiffness, and reinforced with a wood strip *w* when so desired. Between the respective pairs of girts 13 and 14 I arrange a row or series of individual panes, panels or tablets 15 of semi-transparent material, such as translucent glass, or ground, frosted, or sand-blast faced glass; or an equivalent material that will intercept light in a degree to show illumination, as indicated at L in Fig. 8. Each panel has a suitable border frame 16 for its independent support. The series of individually framed translucent panels are disposed adjacent to each other in rows, or in predetermined order, and each panel is independently firmly secured at its upper and lower ends to the horizontal girts 13 and 14 by screws 23 (see Figs. 8 and 9) or other efficient fastening devices. Colored glass can be used in the panels, if desired.

The upright standards 10 are braced by inclined bars 12, brace-stays 7, and end guys 17, substantially as shown in Fig. 1, so as to maintain the series of panels 15 in an approximately even field, or at a common plane and unwavering position.

As illustrated, the apparatus is arranged for three-line signs or advertisements, it being provided with three separate rows of panels; but a greater or less number of rows can be employed if in any instance desired.

The several rows of exhibit-panels are

arranged with open spaces 18 and 19 between the rows, and space 20 beneath the lower row. Narrow spaces 21 may also be left between the adjacent sides of the panels, or their frames can be close together as preferred. These spaces between and beneath the panels afford passage for the air and relieve, in a great measure, the enormous wind pressure that might otherwise be exerted upon the large area of the screen in a gale or storm. The spaces also afford facility for reaching the opposite surfaces of the glass or exhibit panels 15 when a ladder is placed against one side of the structure, in case it is desired to clean, remove, or repair the panels.

The wording or matter to be shown upon the sign is prepared upon small plates that are inserted in the projection instrument. Said plates are best formed of thin metal, or suitable opaque material, and have the letters, numerals, symbols or characters formed therein by small perforations 2, punched or drilled through the metal or plate, as illustrated in Figs. 4, 5 and 6, or in equivalent manner, so that the form of the letter or character will be indicated by points of light passing through the perforations in a series of beams or rays, while the opaque portions of the plate obstruct the passage of light over all parts where not desired.

The individual letters or characters are laid out upon the plate in predetermined relative positions, and to proportionally conform to the predetermined location of the individual panels 15 in the exhibitory-field, so that the light L from the respective letters or characters of the plate C is thrown in divergent rays or beams to the respectively corresponding individual panels 15, there showing as illuminated characters upon the translucent panels in the several rows in a manner similar to that indicated in Fig. 8.

The check lines *f* on Fig. 5 indicate the relative arrangement in respect to the exhibitory field; but such lines are not essentially upon the plates in practice.

Opaque plates having perforated or transparent letters or characters, and made of other material than metal, may in some instances be employed.

In Fig. 5 I have shown the sign plate formed in a single piece; while in Fig. 6 I have illustrated a construction of my improved plate as made to facilitate the changing of the sign or wording thereon. In this the respective letters or characters are formed in individual sections, or separate small pieces 3, which are adapted to be "set up" or arranged within a main plate or frame C' having suitable openings 4 therein corresponding to the rows or lines to be employed.

The individual perforated letter sections 3 are best provided with side flanges 6 that overlap to prevent light passing between the sections; and the frame is furnished with points or lugs 5 that engage recesses 5^a in the letter sections, or vice versa, to indicate the proper relative position for the respective letters or figures, and to retain the same temporarily in place. With this construction the wording can be set up and distributed at will, accordingly as it is desired to change the same, without the necessity of making entire new plates for each change of the reading matter.

15 A series of plates C or C¹, of the character described, are severally secured upon the carrier arm G of the automatic projection apparatus, and brought into the focal rays in their respective successive order, changing the illumination of the sign automatically and as frequently as may be desired; in accordance with the tripping of the automatic mechanism, which latter having been made the subject of my prior application, need not be herein more fully explained.

I claim—

1. A changeable illuminated sign apparatus, comprising a light-projecting instrument, a series of thin metal plates therefor, having the letters, symbols or characters formed therein by perforations through the plate, an exhibitory-field composed of a series of panels of ground, sand-blasted or translucent glass, said panels disposed for the individual display of separate letters or characters, and means for automatically shifting said plates into and from the light-projecting instrument.

2. An illuminated sign comprising, in combination, a source of light, means for concentrating, directing and intensifying the light therefrom, a thin opaque plate having letters, figures or symbols formed therein by series of small perforations through the plate, and a display screen composed of a series of translucent panes or panels, upon which the respective letters or symbols are thrown in beams of light emanating from the source and directed through the respective perforations in said opaque plate.

3. An illuminated-sign apparatus, comprising a light-projecting instrument, a plate therefor having a plurality of adjacently arranged letters, symbols or character-elements disposed in a predetermined order of spacing, and individually outlined therein by groups of small perforations; and an exhibitory field composed of a series of individual translucent panels severally disposed in a predetermined order to correspond with that of the character-elements of the plate, and whereon the several letters, symbols or character-elements are simultaneously displayed, each in its respective

panel and composed of a series of spots of light, substantially as set forth.

4. A changeable illuminated sign, comprising an outstanding exhibitory-field composed of a series of individual semi-transparent panels arranged in predetermined order, a projection instrument arranged for throwing light thereon, and a set of interchangeable variously worded opaque plates having therein rows of perforations representing the letters, symbols or characters, the same being severally disposed upon the respective plates in corresponding coacting relation to the individual panels of said exhibitory-field, and means for successively presenting said plates for display.

5. A changeable illuminated sign apparatus, comprising a standing frame having a plurality of pairs of cross-bars or girts, a plurality of rows of independent adjacently-arranged semi-transparent tablets or panels supported thereon, with open spaces between the respective rows, whereby access can be had to the several panels, means for adjustably securing the cross-bars to the standing members of the frame, means for individually securing the panels to their supports, a series of letter-plates each having letters, symbols or characters arranged thereon in a relative order to correspond to the arrangement of the panels upon the frame, a single letter to a single panel, a light-projecting instrument, a source of light therefor, carrier devices for the series of letter-plates, and means for automatically operating the carrier devices for successively bringing said letter-plates into the illumination field.

6. An exhibitory-field or screen for illuminated signs for advertising purposes; consisting of a supporting frame having semi-opaque or translucent panels arranged thereon in a predetermined order for the individual exhibit upon the respective panel of a separate letter, figure or character, by light thrown thereon, in combination with a small letter-plate having the letters, figures or characters disposed thereon in order similar to that of the said translucent panels, and means for throwing light in divergent rays or beams through said letter-plate to the corresponding panels of the exhibitory-field.

7. In an illuminated sign, the combination of a small letter-plate, consisting of a thin opaque body having rows of perforated letters or characters therein, an exhibitory-field including a plurality of separated rows of semi-transparent material, and means for projecting beams of light through said perforated letters to the individually corresponding rows in the exhibitory-field.

8. An exhibitory-field or screen for illuminated roof-signs of the character described, composed of the upright standards, suitable attaching feet or pedal-blocks therefor,

upper and under transverse rails or girts carried upon said standards, a system of stays or braces for maintaining the uprightness of the standards, and a series of individually framed translucent panes or panels each inclosed by an independent border frame, said border frames having their upper and lower ends secured to and supported by the respective upper and under rails; the individual panels being independently assembled upon their supporting members.

9. In an illuminated sign of the class described, an exhibition screen comprising a supporting frame consisting of upright standards, suitable bracing therefor, a plurality of sets of transverse girts, and a series or row of individual panels of translucent or semi-transparent glass, supported upon each set of girts, said panels independently secured upon the supporting girts, and

having open space between the several rows of panels, for the purpose set forth.

10. In a changeable illuminated sign mechanism, a sign-plate comprising a main body-plate having spaces therein, and a series of separate individual letter-section plates formed of thin opaque material and having the individual letter or character formed by perforations therein; said separate sections adapted to be variously assembled in the spaces within said main body-plate, and means for locating the adjustment of, and securing said section plates at their proper positions upon the main body-plate.

Witness my hand this 14th day of July, 1909.

ROBERT E. LIPPINCOTT.

Witnesses:

A. G. DAVIS,

CHAS. H. BURLEIGH.

Copies of this patent may be obtained for five cents each, by addressing the "Commissioner of Patents, Washington, D. C."