

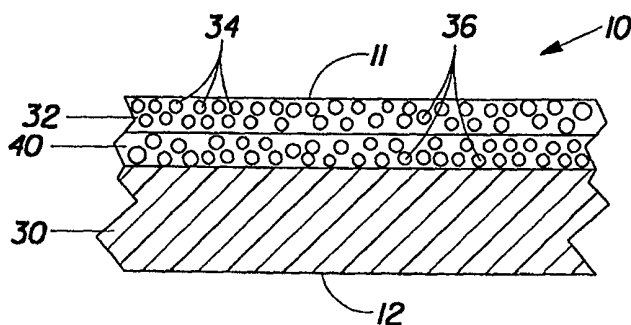

INTERNATIONAL APPLICATION PUBLISHED UNDER THE PATENT COOPERATION TREATY (PCT)

<p>(51) International Patent Classification ⁷ : A47G 19/03, B32B 27/18</p>	A1	<p>(11) International Publication Number: WO 00/27256</p> <p>(43) International Publication Date: 18 May 2000 (18.05.00)</p>
<p>(21) International Application Number: PCT/US99/25934</p> <p>(22) International Filing Date: 3 November 1999 (03.11.99)</p> <p>(30) Priority Data: 09/188,609 9 November 1998 (09.11.98) US</p> <p>(71) Applicant: THE PROCTER & GAMBLE COMPANY [US/US]; One Procter & Gamble Plaza, Cincinnati, OH 45202 (US).</p> <p>(72) Inventor: TOUSSANT, John, William; 8169 Shadybrook Drive, West Chester, OH 45069 (US).</p> <p>(74) Agents: REED, T., David et al.; The Procter & Gamble Company, 5299 Spring Grove Avenue, Cincinnati, OH 45217-1087 (US).</p>	<p>(81) Designated States: AE, AL, AM, AT, AT (Utility model), AU, AZ, BA, BB, BG, BR, BY, CA, CH, CN, CR, CU, CZ, CZ (Utility model), DE, DE (Utility model), DK, DK (Utility model), DM, EE, EE (Utility model), ES, FI, FI (Utility model), GB, GD, GE, GH, GM, HR, HU, ID, IL, IN, IS, JP, KE, KG, KP, KR, KZ, LC, LK, LR, LS, LT, LU, LV, MA, MD, MG, MK, MN, MW, MX, NO, NZ, PL, PT, RO, RU, SD, SE, SG, SI, SK, SK (Utility model), SL, TJ, TM, TR, TT, UA, UG, UZ, VN, YU, ZA, ZW, ARIPO patent (GH, GM, KE, LS, MW, SD, SL, SZ, TZ, UG, ZW), Eurasian patent (AM, AZ, BY, KG, KZ, MD, RU, TJ, TM), European patent (AT, BE, CH, CY, DE, DK, ES, FI, FR, GB, GR, IE, IT, LU, MC, NL, PT, SE), OAPI patent (BF, BJ, CF, CG, CI, CM, GA, GN, GW, ML, MR, NE, SN, TD, TG).</p> <p>Published <i>With international search report. Before the expiration of the time limit for amending the claims and to be republished in the event of the receipt of amendments.</i></p>	

(54) Title: FOOD CONTAINER HAVING EXTERNAL FACING WITH LIMITED BINDER MATERIALS



(57) Abstract

A food container (10) having a first user-facing surface (11) and an opposed second surface (12). At least one cut resistant facing (32) is juxtaposed with and preferably coincident with the first surface (11). The facing (32) comprises particulate material (34). The facing (36) is free of clay, or, alternatively, free of resin. The particulate material (34) preferably comprises particles having a particle size of at least 5 microns and a Mohs hardness of at least 3.

FOR THE PURPOSES OF INFORMATION ONLY

Codes used to identify States party to the PCT on the front pages of pamphlets publishing international applications under the PCT.

AL	Albania	ES	Spain	LS	Lesotho	SI	Slovenia
AM	Armenia	FI	Finland	LT	Lithuania	SK	Slovakia
AT	Austria	FR	France	LU	Luxembourg	SN	Senegal
AU	Australia	GA	Gabon	LV	Latvia	SZ	Swaziland
AZ	Azerbaijan	GB	United Kingdom	MC	Monaco	TD	Chad
BA	Bosnia and Herzegovina	GE	Georgia	MD	Republic of Moldova	TG	Togo
BB	Barbados	GH	Ghana	MG	Madagascar	TJ	Tajikistan
BE	Belgium	GN	Guinea	MK	The former Yugoslav Republic of Macedonia	TM	Turkmenistan
BF	Burkina Faso	GR	Greece			TR	Turkey
BG	Bulgaria	HU	Hungary	ML	Mali	TT	Trinidad and Tobago
BJ	Benin	IE	Ireland	MN	Mongolia	UA	Ukraine
BR	Brazil	IL	Israel	MR	Mauritania	UG	Uganda
BY	Belarus	IS	Iceland	MW	Malawi	US	United States of America
CA	Canada	IT	Italy	MX	Mexico	UZ	Uzbekistan
CF	Central African Republic	JP	Japan	NE	Niger	VN	Viet Nam
CG	Congo	KE	Kenya	NL	Netherlands	YU	Yugoslavia
CH	Switzerland	KG	Kyrgyzstan	NO	Norway	ZW	Zimbabwe
CI	Côte d'Ivoire	KP	Democratic People's Republic of Korea	NZ	New Zealand		
CM	Cameroon	KR	Republic of Korea	PL	Poland		
CN	China	KZ	Kazakstan	PT	Portugal		
CU	Cuba	LC	Saint Lucia	RO	Romania		
CZ	Czech Republic	LI	Liechtenstein	RU	Russian Federation		
DE	Germany	LK	Sri Lanka	SD	Sudan		
DK	Denmark	LR	Liberia	SE	Sweden		
EE	Estonia			SG	Singapore		

food containers, the prior art attempts do not provide food containers of sufficient strength. This lack of strength leads to spillage of food when the food container becomes overloaded, or, alternatively, unduly constrains the amount of foods which can be placed on the food container at a given time.

5 There have been several attempts in the art to improve the rigidity of such food containers. For example, food containers having a bottom wall, a side wall disposed radially outwardly of and circumjacent the bottom wall, and a rim disposed radially outwardly of and circumjacent the side wall are known in the art. Food containers with densified regions in the side wall have been attempted
10 in the art. Likewise, containers having densified circumferentially spaced regions extending radially through annular portions of the rim are known. Such attempts in the art are alleged to provide resistance to bending throughout the entire structure. Illustrative of such attempts are U.S. Pat. nos. 4,606,496 issued Aug. 19, 1986 to Marx et al. and 4,609,140 issued Sept. 2, 1986 to Van Handel et al.

15 Food containers according to the prior art have been coated to improve resistance to penetration by liquids, such as grease, etc. Coatings have also been used to attempt to provide cut resistance in the finished product, gloss, ink receptivity, etc. An example of such attempts is U.S. 5,776,619 issued July 7, 1998 to Shanton. Shanton teaches a coated paper board having two coatings, a
20 base coat and a top coat. Each coating consists of a polymer latex and a particulate pigment. The top coat has a blend of about 90 parts kaolin clay, having approximately 80% of the particles less than two microns in size. Furthermore, U.S. 5,709,913 issued Jan. 20, 1998 to Andersen et al. discloses, in Example 112, inorganically filled paper plates which are allegedly more rigid
25 than conventional paper plates.

 Another attempt in the art is illustrated by U.S. 5,635,279 issued June 3, 1997 to Ma et al. Ma et al. discloses paperboard having a polymer matrix/wax/pigment mixture applied as an aqueous formation and suited for corrugated box constructions. The coating consists of pigments, including
30 natural and synthetic silicates, bentonite, clay, etc. U.S. 5,494,716 issued Feb. 27, 1996 to Seung et al. discloses a food tray having an aqueous coating with a styrene/acrylic latex and other agents. U.S. 5,334,449 issued Aug. 2, 1994 to

Bergmann discloses a paper having a prime coat and a mixture of kaolin, calcium carbonate, casien and butadiene-styrene latex. U.S. 5,100,472 issued Mar. 31, 1992 to Fugitt et al. discloses a paper coating containing dionized clay or calcium carbonate.

5 Similar attempts have been made in nonanalogous art to utilize particulates for abrasion resistance. For example, U.S. 5,558,906 issued Sept. 24, 1996 to Albrinck et al. discloses a decorative laminate having an abrasion resistant material including alumina particles having particle sizes of about 25 microns and at about 3 microns in a 2-1 ratio.

10 Additionally, mineral pigments such as titanium dioxide, and water and soluble particulate fillers such as kaolin clay have been used as opacifying agents in nonanalogous arts, such as tissue. Examples include commonly assigned U.S. 4,952,278 issued Aug. 28, 1990 to Gregory et al.; U.S. 5,611,890 issued Mar. 18, 1997 to Vinson et al.; and 5,672,249 issued Sept. 30, 1997 to
15 Vinson et al., the disclosures of which are incorporated herein by reference. Additionally, fillers and cationic starch have been taught in nonanalogous arts such as the production of news print as found in U.S. 5,670,021 issued Sept. 23, 1997 to Owens.

Accordingly, this invention provides a food container having a cut resistance
20 surface which is simpler in execution and consumer preferred over the surfaces provided by the attempts in the prior art. Particularly, this invention provides a food container having a cut resistance surface which not only improves resistance to inadvertent cutting and to penetration by liquid such as grease, but also provides a preferred tactile feel, when using common eating utensils such as
25 silverware.

SUMMARY OF THE INVENTION

This invention comprises a food container. The food container has a first user-facing surface and a second surface opposed to the first surface. The food
30 container has a cut-resistant particle containing external facing juxtaposed with, and preferably coincident, the first surface. The external facing has particulate material and a second binder material disposed therein. The particulate material

has a Mohs hardness of at least 3 and preferably at least 7. If desired, an intermediate facing may be disposed between the external facing and the substrate. At least one of the intermediate facing and external facing are free of clay, free of resin, or free of both. The particulate material has a particle size of
5 at least 5 microns, and preferably at least 10 microns.

BRIEF DESCRIPTION OF THE DRAWINGS

Fig. 1 is a perspective view of a food container according to the present invention.

10 Fig. 2 is a schematic fragmentary sectional view taken along lines 2-2 of Fig. 1.

Fig. 3 is a schematic fragmentary sectional view similar to that of Fig. 2 and showing a food container having an intermediate facing.

DETAILED DESCRIPTION OF THE INVENTION

15 Referring to Figs 1-2, the food container 10 according to the present invention may comprise a plate, bowl, tray, clam shell, cutting board or any other configuration known in the art.

20 Typically the food container 10 according to the present invention has a concave first surface 11 and a convex second surface 12. The concave first surface 11 of the food container 10 is that side which typically faces the user while in use. The convex side of the food container 10 typically faces away from the user in use and may rest upon a horizontal surface such as a table.

25 The food container 10 thus comprises a first user-facing surface and a second surface 12 opposed to the first surface 11. The food container 10 further has a cut-resistant external facing 32 juxtaposed with, and preferably coincident, the first surface 11. The cut-resistant external facing 32 comprises particulate material 34 disposed in a single stratum. Particulate material 34 of the cut-resistant external facing 32 is disposed on and carried by a substrate 30.

30 The food container 10 comprises a central region 14 and a circumjacent periphery 16. The central region 14 and periphery 16 are preferably disposed in two different planes, although a flat food container 10 is contemplated as a less

preferred embodiment. A flat food container 10, may, for example, have utility as a food tray or cutting board.

The central region 14 defines the XY plane of the food container 10. The Z-direction of the food container 10 lies perpendicular to the XY plane. The food container 10 has a transition region 20 from the central region 14 to the periphery 16. The periphery 16 may be spaced apart in the Z-direction from the central region 14, or the food container 10 may be flat, as described above. In normal use, the periphery 16 is raised relative to the central region 14. The central region 14 of the food container 10 defines a first portion of the food container 10. Likewise, the periphery 16 of the food container 10 defines a second portion of the food container 10.

Thus, the food container 10 is preferably multi-planar. By multi-planar, it is meant that the different portions of the food container 10 lie in different planes. An example of the multi-planarity of the food container 10 of the present invention is illustrated by the central region 14 and periphery 16 of the food container 10. The central region 14 and periphery 16 of the food container 10 are spaced apart in the Z-direction, thus rendering the food container 10 multi-planar.

It may be necessary to accommodate the accumulation of material which occurs when the food container 10 is formed. Pleats or gathers are often used for this purpose, as is known in the art. Pleats and gathers, particularly accumulation pleats having a radial orientation, are contemplated.

It is not necessary that either the central region 14 or the periphery 16 be parallel to the XY plane or generally planar. For example, bowls having a generally concave shaped bottom will be suitable for use with the present invention. The Z-direction distance from the bottom surface of the central region 14 (taken while the food container 10 is in its normal in use and generally horizontal position) to the top surface of the periphery 16 as referred to as the Z-direction depth 19 of the food container 10. If there are different depths at different portions of the food container 10, the Z-direction depth is taken as that greatest Z-direction distance.

The boundary and shape of the periphery 16 are defined by the edge 18 of the food container 10. It is to be recognized that the dimensions and relative proportions of the periphery 16 and central region 14 of the food container 10 will vary according to the exact size and intended use of the food container 10. While
5 a round food container 10 is contemplated, one of ordinary skill will recognize that any suitable shape and depth of food container 10 may be selected for use with the present invention and the invention is not so limited. Other suitable shapes include squares, rectangles, ovals, various polygons, etc.

The substrate 30 of the food container 10 may be comprised of at least two
10 plies, a first ply and a second ply. The second ply may be smaller than the first ply, so that at least part of the food container 10 is free from the second ply. The second ply and the first ply may be concentric. It is to be recognized that an alternative embodiment (not shown) of the food container 10 may comprise three or more plies.

In a particularly preferred embodiment, the food container 10 comprises a
15 single ply of a rigid material, particularly a material which provides for carrying the cut-resistant external facing 32 in juxtaposition and preferably coincident with the user-facing surface of the food container 10. Suitable rigid materials include foam, plastic and various other synthetic materials. The food container 10 is
20 preferably made of cellulose and may be made of kraft, solid bleached sulfite (SBS), or layers of various paper fibers including recycled cellulose. The food container 10 may be molded from a pulp slurry or pressed from a blank between mating platens. Both methods of manufacture are well known in the art.

The external facing 32 provides resistance to penetration of hot greasy
25 foods into the substrate 30 of the food container 10. Also, the external facing 32 provides a tactile sensation which is not unpleasant when the user touches the first surface 11 of the food container 10, or cuts food thereon with an eating utensil such as a knife.

One of ordinary skill will recognize that a particulate material 34 is
30 particularly preferred for the external facing 32. A material having discrete and separate particles allows the facing to be hard and cut resistant without being brittle. This combination allows the food container 10 to be handled, shipped,

etc., during normal transportation and use - without breaking, spalling, delamination or chipping of the external facing 32 surface.

It is important that the first surface 11 of the food container 10 be hard yet flexible - rather than hard and brittle. This arrangement further allows the first surface 11 of the food container 10 to be cut-resistant. As used herein, a surface is considered to be "cut-resistant" if the surface allows the user to exert normal pressures while eating cooked and other prepared foods without ordinarily penetrating through the substrate 30 of the food container 10. It is further important that the first surface 11 provides the proper tactile sensation directly to the fingertips and as transmitted through various eating utensils.

It is preferred that the particulate material 34 comprising the external facing 32 have a Mohs hardness of at least 3, preferably at least 7, and even approaching or greater than 9. A Mohs hardness between 6.5 and 7.5 has been found suitable for use with the food container 10 of the claimed invention. The Mohs hardness scale (measured on a 1 to 10 talc to diamond scale) of the particulate materials 34 of the external facing 32 are well documented in reference handbooks such as pages 4-132 to 4-139, 12-93 to 12-97, and 12-205 to 12-206 of The Handbook of Chemistry and Physics, 78th Edition, 1997-1998 incorporated herein by reference. Of course, the hardness of the particulate material 34 comprising the external facing 32 is determined prior to incorporating the particulate material 34 into or disposing the particulate material 34 on the substrate 30 of the food container 10.

By providing a particulate material 34 of the aforementioned hardness, a food container 10 having the proper and preferred tactile sensation is attainable. Such a hardness allows the user to cut foods on the food container 10 with a sharp knife, without experiencing the unpleasant occurrence when the knife cuts through the food container 10, allowing gravy, au jus, etc., to leak through the food container 10.

Furthermore, it has been unexpectedly found that the particulate material 34 has a preferred particle size. The preferred particle size is necessary to impart the tactile sensation of toughness without being unpleasant to the touch.

The, user will not be afraid to cut food disposed on such a food container 10 with a sharp knife or other eating utensil.

The particulate material 34 comprising external the facing 32 has a particle size of at least 5 microns, and preferably 10 microns. The particulate material 34 may range in size from 20 to 200 microns, and possibly range from 50 to 200 microns. Particle size is measured using an L3P Sonic Sifter Separator, ATM available from VWR Scientific Products Corp., catalog number 57353-035.

The particulate material 34 comprising the external facing 32 may be a mixture of or several mixtures of mineral and other types of particulates known in the art and commercially available. For example, various particulates comprising alumina, silica, carbonate, oxides, carbides, nitrides, bromides, hard metals, hard alloys, hard elements. If carbides are selected, suitable carbides include tantalum carbide, tungsten carbide, zirconium carbide, beryllium carbide or silicone carbide (carborundum). If a boride is selected, suitable borides include aluminum boride, tantalum boride, zirconium boride, and titanium boride. Boron may also be used. If a nitride is selected, suitable nitrides include aluminum nitride, zirconium nitride and titanium nitride. Metals, including hard metal alloys, such as iron, steel and chromium may be used for the particulate material 34. Ceramics, such as stoneware and particularly porcelain type ceramic particulate materials 34 have been found suitable. More particularly, aluminum oxide (corundum), silicone dioxide (quartz), calcium carbonate, potassium aluminum silicate and feldspar are suitable. Silicone dioxide, calcium carbonate, and aluminum oxide are available from the J.T. Baker Company, a division of Mallinckroft Baker, Inc., of Phillipsburg, NJ, under catalog numbers JT3405, JT1301, and JT0536, respectively.

The particulate material 34 may further comprise clay. A kaolin clay has been found particularly well suited. Suitable kaolin clay is available from the J.T. Baker Company of Phillipsburg, NJ under catalog number JT2242.

A suitable mixture for the external facing 32 has been found to be 80% kaolin clay and 20% aluminum oxide. Another suitable mixture has been found to be 80% kaolin clay and 20% calcium carbonate. All percentages described herein are weight percentages, unless otherwise specified.

The particulate material 34, including any optional clay, may be added to a water-based resin to form a coating. An acrylic resin is particularly preferred. A suitable coating may have 50 to 90% resin with 10 to 50% particulate material 34 mixed therein.

5 A suitable add-on level for the particulate material 34 comprising the external facing 32 of first surface 11 of the food container 10 is from about 0.5 to 100 grams per square meter, and preferably from about 1 to 50 grams per square meter. A round food container 10 having a finished diameter of about 22.9 centimeters and 0.1 to 2 grams of particulate material 34 comprising the
10 external facing 32 has been found suitable.

It is desired that the particulate material 34, including any resin or other carrier used therewith, be applied to the substrate 30 of the food container 10 as a single stratum. The single stratum provides the benefits over the dual strata teachings of the prior art of more precise control of the add-on levels, a single
15 application operation, and is accommodated by a commercial drying operation. In contrast, the dual strata teachings of the prior art require double the inventory of raw materials and double the machinery to apply the particulate material 34 to the substrate 30.

The coating, which ultimately comprises the external facing 32, may be
20 applied to the substrate 30 of the food container 10 after it is formed. The coating comprising the particulate material 34 may be applied by blade coating, printing, or spraying as are known in the art. If blade coating is used, the hardness of the blade must be at least as hard as the particulate material 34. Preferably, an air knife coating process is used to apply the particulate mixture to
25 the substrate 30. Preferably, the substrate 30 of the food container 10 is not dipped into the coating - so that the second surface 12 of the food container 10 remains uncoated.

One of ordinary skill will recognize that many variations are feasible. For example, the particulate material 34 may be applied in a gradient. The gradient
30 preferably has a greater add-on level near the center of the food container 10 where more cutting typically occurs in use. Less of the particulate material 34 may be applied to the exposed sides and periphery 16 of the food, which typically

function to hold the food within the periphery 16 of food container 10. This allows for conservation of the particulate material 34 as well as concentrating the particulate material 34 in the area which typically receives the greatest wear in use. Such an arrangement provides a Z-direction gradient, with concentration
5 increasing as the center of the food container 10 is approached and decreasing as the edge of the food container 10 is approached.

Alternatively, the particulate material 34 may vary in an XY pattern between regions of the first surface 11 having the particulate material 34 and regions free of the particulate material 34. The particulate material 34 may, for example, be
10 applied in a checkerboard pattern or in stripes. Suitable patterns of stripes include concentric rings, radial lines (either straight or spiral), parallel lines, etc. This arrangement provided the benefit that the food container 10 is flexible in the regions not having the particulate material 34 and yet hard in the regions having the particulate material 34. Thus a food container 10 which has a cut resistant
15 external facing 32 will still result.

Optionally, the external facing 32 may be provided with at least one overcoat (not shown). The overcoat serves to protect the particulate material 34 and the external facing 32 from becoming dislodged from the substrate of the food container 10. Additionally, the overcoat defines and provides a relatively
20 smoother first surface 11. Preferably, the overcoat does not provide a first surface 11 which is too smooth, otherwise the proper tactile sensation may not result.

The overcoat(s) may comprise an acrylic resin. Preferably, the acrylic resin is relatively transparent or translucent, so that an aesthetically pleasing first
25 surface 11 will result. The overcoat may be applied by printing, spraying, dipping, blade coating, air knife coating, etc. as known in the art.

One of ordinary skill will recognize that the external facing 32 may comprise one stratum or plural strata. The external facing 32 will, at most, have only a single binder material 36 - without regard to the number of strata. Binder
30 materials 36 include clay, resin, and other particulate matter which may or may not have a Mohs hardness greater than 3, but serve to bind the particulate material 34 into a matrix comprising the external facing 32. Thus, the external

facing 32 will be free of clay, free of resin or free of both while still containing the particulate material 34.

If multiple strata are used for the external facing 32, one stratum may be free of resin while the other stratum may be free of clay. One stratum may be free of both resin and clay.

Of course, one of ordinary skill will recognize that at the interface between the strata, there may be some slight intermingling of the clay and the resin binder materials. Likewise, such intermingling may occur between the external facing 32 and the substrate 30 of the food container 10. However, such intermingling does not prevent either stratum of the external facing 32 from consisting essentially of a particulate material 34 and a single binder material 36. Intermingling at the interface may occur due to migration of the various binder materials 36 between the plural strata of the external facing 32.

The external facing 32 is disposed on the substrate 30. The condition of being "disposed on" includes configurations where the external facing 32 resides directly upon the substrate 30 as well as configurations where the external facing 32 is connected to the substrate 30 through an intermediate member, such as an intermediate facing 40. The intermediate facing 40 may have the same composition as the external facing 32.

Referring to Fig. 3, preferably, however, the intermediate facing 40 and the external facing 32 have different compositions. This allows one to tailor the intermediate facing 40 and external facing 32 to the particular desired properties. For example, one of the external facing 32 and intermediate facing 40 may be free of resin. The other of the external facing 32 and intermediate facing 40 may be free of clay. One of the external facing 32 and intermediate facing 40 may be free of both resin and clay. The other may contain clay or resin.

Alternatively, the external facing 32 may contain only a single binder material 36 while the intermediate facing 40 contains both (or a single) binder material 36. All such variations are contemplated and within the scope of the claimed invention.

WHAT IS CLAIMED IS:

1. A food container, said food container comprising a first user facing surface and a second surface opposed thereto, said food container having an external facing juxtaposed with said first surface, characterized in that said external facing consists essentially of a particulate material and a single binder material.
2. A food container according to Claim 1 wherein said binder material comprises resin.
3. A food container according to Claim 1 wherein said binder material comprises clay.
4. A food container according to Claims 1, 2, 3, and 4 further comprising a substrate, and further comprising an intermediate facing disposed on said substrate, said intermediate facing being between said substrate and said external facing, said intermediate facing comprising a particulate material.
5. A food container according to Claim 4 wherein said intermediate facing further comprises clay or resin.
6. A food container, said food container having a first user facing surface and a second surface opposed thereto, said food container comprising a substrate having an intermediate facing disposed thereon, said food container further comprising an external facing disposed on said intermediate facing and defining said first surface, each of said intermediate facing and said external facing comprising particulate material, characterized in that one of said intermediate facing and said external facing is free of clay or resin.

7. A food container according to Claims 1, 2, 3, 4, 5, and 6 wherein said particulate material has a Mohs hardness of at least about 3.
8. A food container according to Claims 1, 2, 3, 4, 5, 6, and 7 wherein said particulate material has a particle size of at least 5 microns.
9. A food container according to Claims 1, 2, 3, 4, 5, 6, 7, and 8 further comprising an overcoat.

1/1

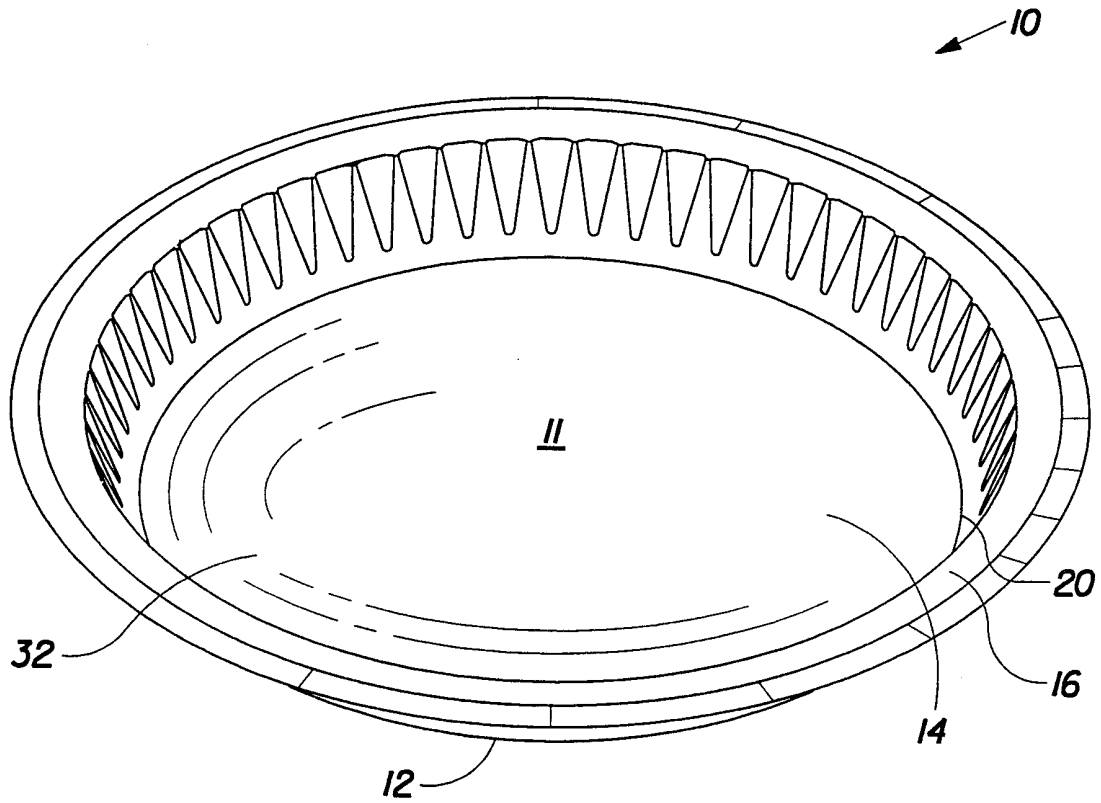

FIG. 1

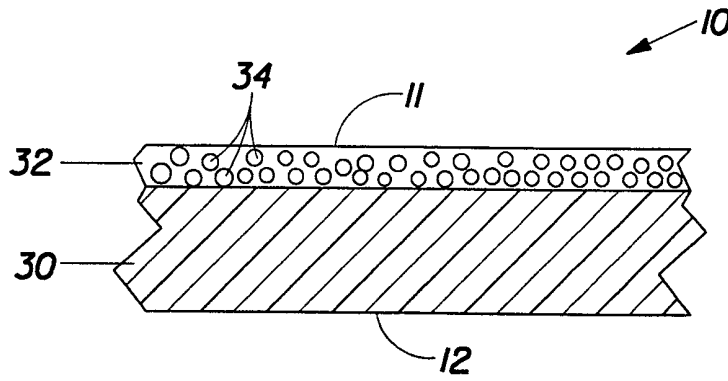

FIG. 2

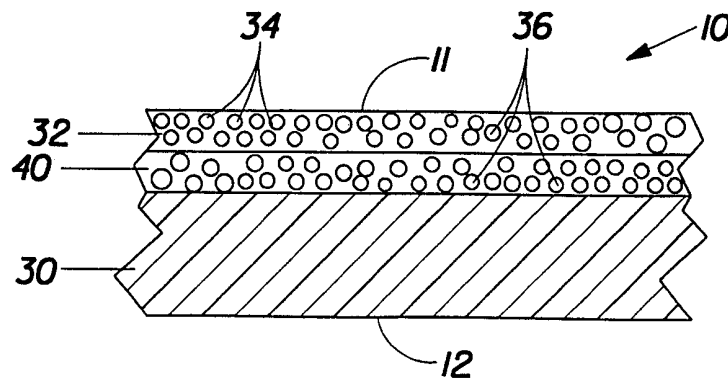

FIG. 3

INTERNATIONAL SEARCH REPORT

Inter. Appl. Application No
PCT/US 99/25934

A. CLASSIFICATION OF SUBJECT MATTER
IPC 7 A47G19/03 B32B27/18

According to International Patent Classification (IPC) or to both national classification and IPC

B. FIELDS SEARCHED

Minimum documentation searched (classification system followed by classification symbols)
IPC 7 A47G B32B A47J B65D

Documentation searched other than minimum documentation to the extent that such documents are included in the fields searched

Electronic data base consulted during the international search (name of data base and, where practical, search terms used)

C. DOCUMENTS CONSIDERED TO BE RELEVANT

Category *	Citation of document, with indication, where appropriate, of the relevant passages	Relevant to claim No.
X	EP 0 345 053 A (DU PONT) 6 December 1989 (1989-12-06)	1,2,6-9
A	page 3, line 5 -page 4, line 43	4,5
A	US 5 300 747 A (SIMON FREDERICK E) 5 April 1994 (1994-04-05)	
A	US 5 562 872 A (WATANABE TADAO) 8 October 1996 (1996-10-08)	
A	US 4 623 565 A (HUYBRECHTS JOZEF T ET AL) 18 November 1986 (1986-11-18)	

Further documents are listed in the continuation of box C.

Patent family members are listed in annex.

* Special categories of cited documents :

- "A" document defining the general state of the art which is not considered to be of particular relevance
- "E" earlier document but published on or after the international filing date
- "L" document which may throw doubts on priority claim(s) or which is cited to establish the publication date of another citation or other special reason (as specified)
- "O" document referring to an oral disclosure, use, exhibition or other means
- "P" document published prior to the international filing date but later than the priority date claimed

- "T" later document published after the international filing date or priority date and not in conflict with the application but cited to understand the principle or theory underlying the invention
- "X" document of particular relevance; the claimed invention cannot be considered novel or cannot be considered to involve an inventive step when the document is taken alone
- "Y" document of particular relevance; the claimed invention cannot be considered to involve an inventive step when the document is combined with one or more other such documents, such combination being obvious to a person skilled in the art.
- "&" document member of the same patent family

Date of the actual completion of the international search

24 February 2000

Date of mailing of the international search report

15/03/2000

Name and mailing address of the ISA

European Patent Office, P.B. 5818 Patentlaan 2
NL - 2280 HV Rijswijk
Tel. (+31-70) 340-2040, Tx. 31 651 epo nl,
Fax: (+31-70) 340-3016

Authorized officer

Vistisen, L

INTERNATIONAL SEARCH REPORT

information on patent family members

Inter. Patent Application No

PCT/US 99/25934

Patent document cited in search report	Publication date	Patent family member(s)	Publication date
EP 0345053 A	06-12-1989	US 4873137 A	10-10-1989
		AU 616762 B	07-11-1991
		AU 3589789 A	07-12-1989
		CA 1305038 A	14-07-1992
		DE 68917993 D	13-10-1994
		DE 68917993 T	16-02-1995
		JP 1859269 C	27-07-1994
		JP 2025330 A	26-01-1990
		JP 5077511 B	26-10-1993
		MX 166940 B	15-02-1993
		NZ 229367 A	26-02-1991
		US 5300747 A	05-04-1994
US 5562872 A	08-10-1996	JP 2107039 C	06-11-1996
		JP 6237870 A	30-08-1994
		JP 8000096 B	10-01-1996
		US 5433424 A	18-07-1995
US 4623565 A	18-11-1986	EP 0205986 A	30-12-1986
		JP 61288815 A	19-12-1986
		ZA 8509807 A	17-09-1986