

No. 626,687.

Patented June 13, 1899.

J. S. GOLDBERG.

AUTOMATIC MACHINE FOR FEEDING, INSERTING, AND SETTING LACE FASTENERS.

(Application filed Feb. 10, 1898.)

(No Model.)

5 Sheets—Sheet 1.

Fig. 1.

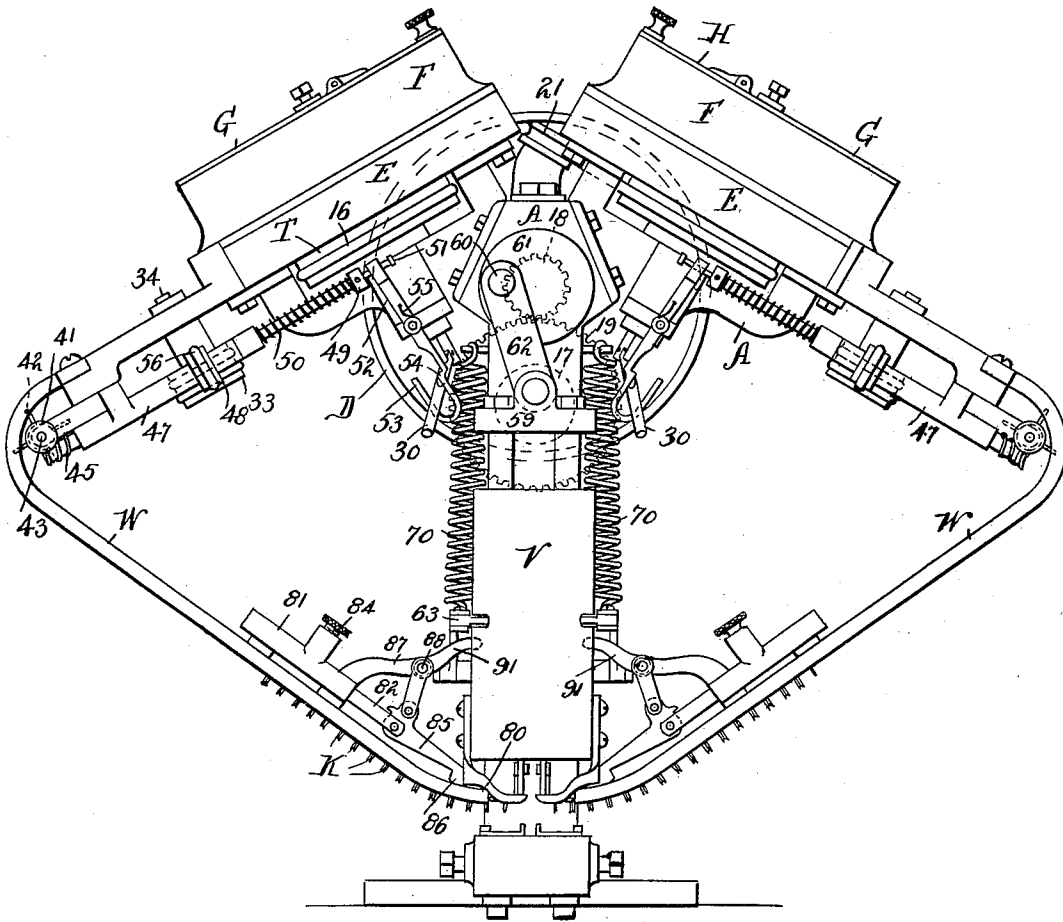

Witnesses
Wm. M. Rhein
Wm. J. Gunning

Inventor
John S. Goldberg
by Brown & Darby
attys.

No. 626,687.

Patented June 13, 1899.

J. S. GOLDBERG.

AUTOMATIC MACHINE FOR FEEDING, INSERTING, AND SETTING LACE FASTENERS.

(Application filed Feb. 10, 1898.)

(No Model.)

5 Sheets—Sheet 2.

Fig. 2.

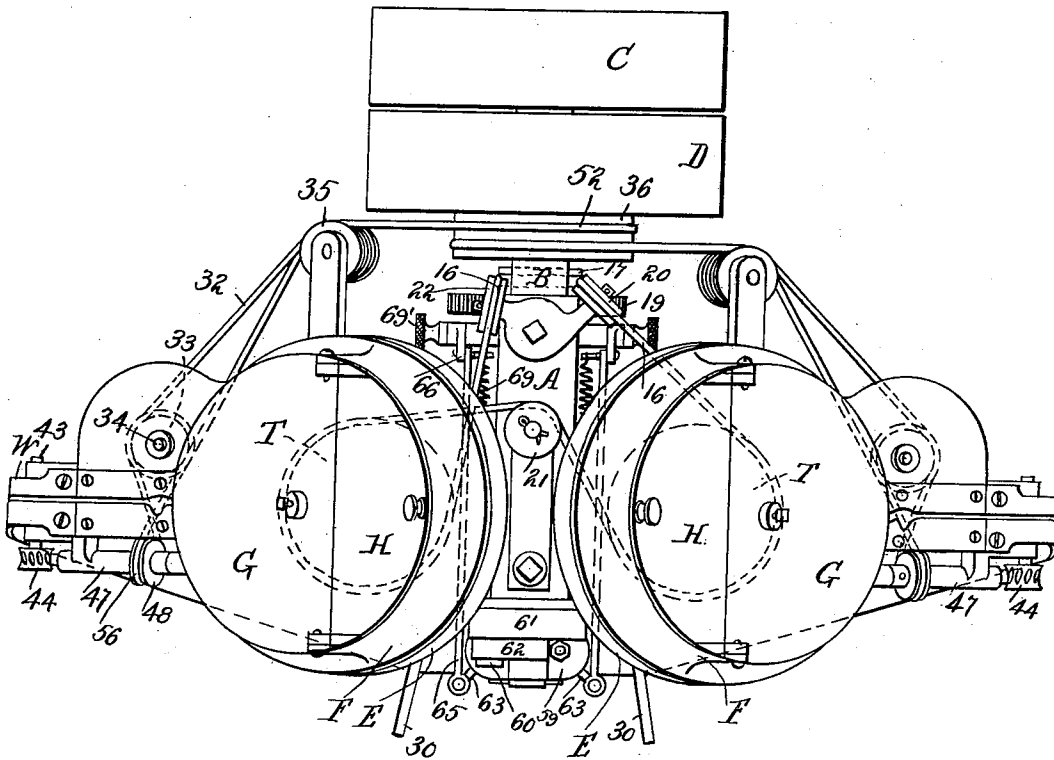

Witnesses.

Wm. M. Rheem.
Wm. J. Hamming

Inventor
John S. Goldberg
by Brown & Darby
Attys

No. 626,687.

Patented June 13, 1899.

J. S. GOLDBERG.

AUTOMATIC MACHINE FOR FEEDING, INSERTING, AND SETTING LACE FASTENERS.

(Application filed Feb. 10, 1898.)

(No Model.)

5 Sheets—Sheet 3.

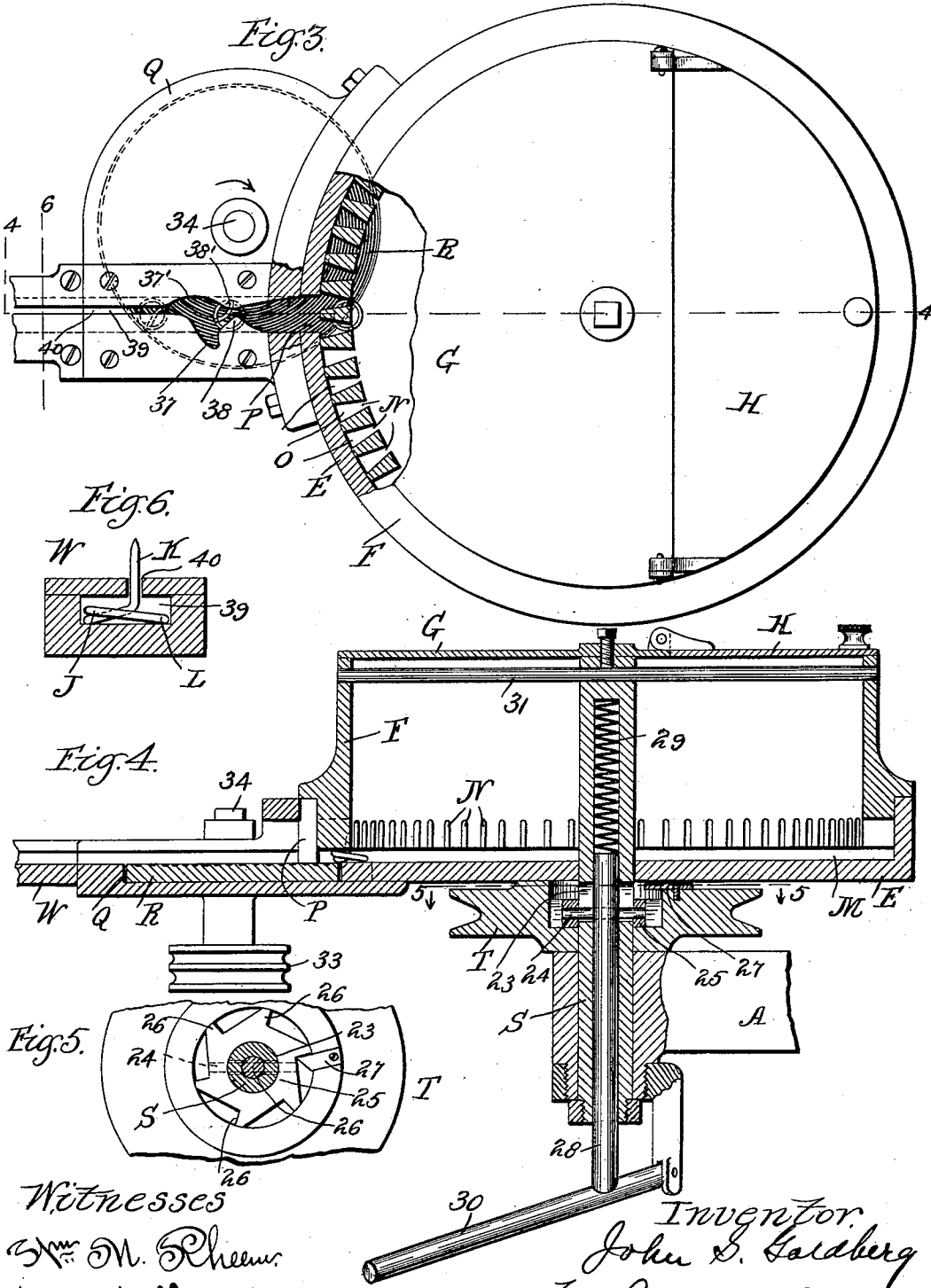

Witnesses
 Wm. M. Scheuer
 Wm. J. Fleming

Inventor
 John S. Goldberg
 by Prosser & Darby
 Attys

No. 626,687.

Patented June 13, 1899.

J. S. GOLDBERG.

AUTOMATIC MACHINE FOR FEEDING, INSERTING, AND SETTING LACE FASTENERS.

(Application filed Feb. 10, 1898.)

(No Model.)

5 Sheets—Sheet 5.

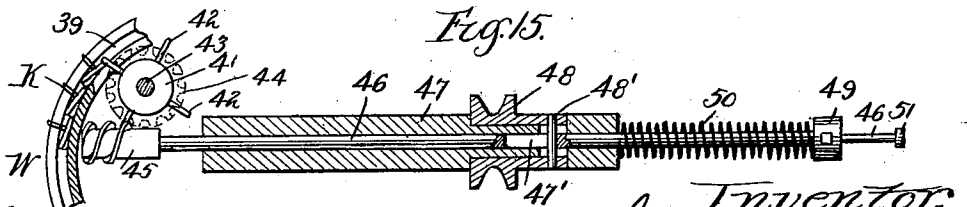
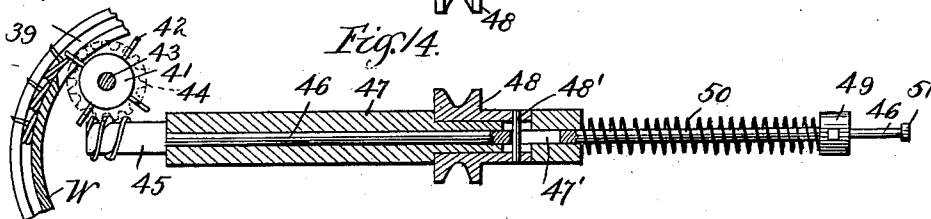
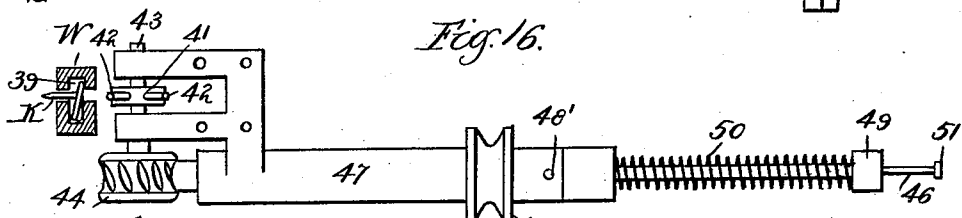
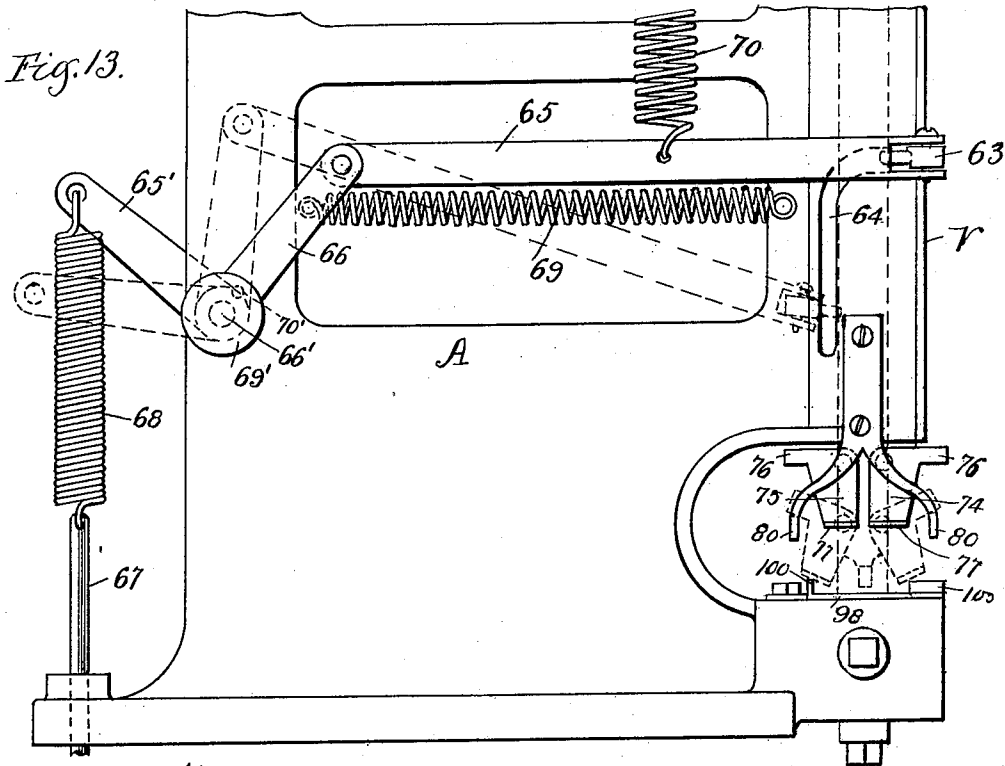

Witnesses.
 Wm. M. Rheem.
 Wm. F. Hanning

Inventor,
 John S. Goldberg
 by Brown & Parry
 Attys

UNITED STATES PATENT OFFICE.

JOHN S. GOLDBERG, OF CHICAGO, ILLINOIS, ASSIGNOR TO THE TITAN
FASTENER COMPANY, OF SAME PLACE.

AUTOMATIC MACHINE FOR FEEDING, INSERTING, AND SETTING LACE-FASTENERS.

SPECIFICATION forming part of Letters Patent No. 626,687, dated June 13, 1899.

Application filed February 10, 1898. Serial No. 669,870. (No model.)

To all whom it may concern:

Be it known that I, JOHN S. GOLDBERG, a citizen of the United States, residing at Chicago, in the county of Cook and State of Illinois, have invented a new and useful Automatic Machine for Feeding, Inserting, and Setting Lace-Fasteners, of which the following is a specification.

This invention relates to automatic machines for feeding, inserting, and setting lace-fasteners.

The object of the invention is to provide a machine of simple construction and efficient in operation for automatically distributing, feeding, inserting, and setting lace-fasteners, and it is particularly designed for use in feeding, inserting, and setting fasteners of the type, form, and construction set forth in Patent No. 586,818, granted July 20, 1897, to E. D. Heinemann.

The invention consists, substantially, in the construction, combination, location, and relative arrangement of parts, all as will be more fully hereinafter set forth, as shown in the accompanying drawings, and finally specifically pointed out in the appended claims.

Referring to the accompanying drawings and to the various views and reference-signs appearing thereon, Figure 1 is a view in front elevation of a machine embodying the principles of my invention. Fig. 2 is a plan view of the same. Fig. 3 is a broken detail view in plan, parts broken out and parts in section, showing the construction and arrangement of means for delivering the fasteners into the feed chute or raceway from the feed-hopper. Fig. 4 is a vertical central sectional view of the same on the line 4 4, Fig. 3. Fig. 5 is a sectional view on the line 5 5, Fig. 4, looking in the direction of the arrow and showing the arrangement of a clutch by which the feed-hopper is thrown into and out of action. Fig. 6 is a view in transverse section of the feed chute or raceway on the line 6 6, Fig. 3. Fig. 7 is a broken detail view, in vertical section, showing the construction and arrangement of fastener-setting mechanism and the means for positively delivering the fasteners from the end of the chute or raceway and upon a temporary support in line with the setting-plungers. Fig. 8 is a plan view of the same,

part being in transverse horizontal section on the line 8 8, Fig. 7, looking in the direction of the arrows. Fig. 9 is a detached detail broken view of the setting-plunger, the engaging and cooperating parts of which are shown detached and separated. Fig. 10 is a detached detail view in plan of the temporary support for the fasteners in line with the setting-plunger, the supporting-bar therefor being in transverse section on the line 10 10, Fig. 11, looking in the direction of the arrows. Fig. 11 is a detached detail view in elevation of the same, looking from the right side of Fig. 10. Fig. 12 is a view in vertical central section showing the anvil arranged to cooperate with and in cooperative relation with respect to the setting-plungers shown in Fig. 7. Fig. 13 is a broken view in side elevation of the lower end of the machine-frame and plunger-casing and showing the arrangement of fastener-retaining means and the means for throwing the plunger parts into and out of operative relation with respect to each other. Fig. 14 is a detached detail broken view in central longitudinal section showing the means for automatically arresting the operation of the distributing-hopper, showing the parts in one limit of their movement. Fig. 15 is a similar view showing the parts in the opposite limit of their movement. Fig. 16 is a plan view of the same, the feed-chute or raceway being in transverse section.

The same part is designated by the same reference-sign wherever it occurs throughout the several views.

In a companion application executed jointly by myself and E. D. Heinemann, Serial No. 670,597, filed February 16, 1898, is shown and described an automatic machine for inserting and setting lace-fasteners and wherein certain features, combinations, and arrangements of elements constituting our joint invention are claimed and wherein, although claim is made only to certain features and combinations as our joint invention, the entire machine is described specifically and in detail in order to enable a complete understanding of the construction, arrangement, and cooperative relation of the apparatus. In the present application the same construction in all its

details is shown in the drawings, but only such parts and combinations of elements as form the subject of my sole invention will be claimed herein.

5 In the drawings reference-sign A designates a suitable framework of a construction and arrangement adapting it to support the several parts of the apparatus. In the framework is suitably journaled to rotate a main
10 driving-shaft B, upon which may be mounted suitable driving-gears—such, for instance, as fast and loose pulleys C D—adapted to receive rotation from any suitable or convenient source and through which motion is im-
15 parted to the various operative parts of the apparatus.

In the particular form of apparatus shown, to which, however, I do not desire to be limited or restricted, provision is made for feeding both “right” and “left” fasteners—that is, fasteners that are to be applied on the right-hand side of the shoe and also on the left-hand side of the shoe. Therefore the arrangement of apparatus is duplicated on opposite sides
25 of the machine. In the following description, however, I will refer only to the construction and arrangement on one side of the machine, it being understood that in a double-acting or duplicated machine the parts hereinafter
30 to be described are the same on both sides.

I will first describe the feed-hopper and its accessory parts and the means for operating the same, particular reference being had to Figs. 3, 4, and 5.

35 Suitably mounted or formed on frame is a plate E, having an upturned circularly-arranged flange. Suitably arranged to rest upon this upturned flange is a cylindrical casing F, forming what I shall term a “hopper,” into
40 which the fasteners are dumped promiscuously, it being understood, of course, that only right fasteners are dumped into the hopper on one side of the machine and only left fasteners are dumped into the hopper on the
45 other side of the machine. Preferably the hopper F and its supporting flanged plate E are arranged upon an incline, as clearly shown in Figs. 1 and 2, whereby the fasteners dumped into the hopper gravitate to the lower portion
50 of the hopper. If desired, the top of the hopper may be covered by a cap or plate G, a portion H of which may be hinged to provide ready access to the hopper, through which the fasteners may be introduced thereto.

55 While a machine constructed in accordance with my invention is adapted for use in distributing, feeding, inserting, and setting many forms of fasteners or other articles, it is, as above set forth, particularly designed for use in feeding, inserting, and setting the form of fastener shown in the patent to Heinemann
60 referred to. This form of fastener comprises a coiled body portion formed of one or more complete coils or convolutions and a superposed partial coil or convolution, such body portion
65 terminating in ends K, projecting at substantially right angles to the plane of the coils

of the body portion, as more particularly described in the patent referred to. It will be seen, however, that the plane containing the two ends K of the fastener does not intersect the plane of the body portion or coils of the fastener diametrically, but the plane containing said projecting ends cuts the plane containing the coils of the body portion to one side of the geometric center thereof, thus leaving a portion J (see Fig. 6) of the body somewhat greater than a semicircle and a portion L somewhat less than a semicircle, and in the particular form of fastener shown in said patent the portion L of the body contains only one strand of the coil, while the portion J of the body includes the superposed partial coil, as well as a portion of the complete coil of such body. With this form and construction of fastener clearly in mind I will now proceed to describe the specific construction of hopper and cooperating means accessory thereto, which are particularly adapted to the feeding and delivering of fasteners of the particular type referred to, it being understood, however, that my invention is not limited to the feeding and distributing of fasteners of this particular type or construction, as the principles of the invention may be equally well adapted for use in feeding and distributing fasteners of other constructions.

Referring to Figs. 3 and 4, it will be seen that the cylindrical casing F, forming part of the hopper, is so supported upon the upturned circular flange of plate E as to leave a clear space M between the lower edge of said casing and the top surface of said plate. This space is just sufficient to receive the body portion or coils of the fastener when resting flatwise upon the upper surface of plate E, with the ends K thereof projecting upwardly therefrom. In other words, the distance between the lower edge of casing F and the top surface of plate E corresponds substantially to the axial thickness of the body portion of the fastener. In the lower edge of cylindrical casing F are suitably cut or otherwise formed a series of slots or passages N, each of which being of an area permitting the passage therethrough of only one leg or end K of a fastener, said slots or passages being of a depth measuring from the lower edge of casing F, corresponding to the length of the legs or ends K of the fastener, and said slots or passages are spaced a distance apart corresponding to the distance between the two legs or ends of the fastener. From this construction and arrangement it will be seen that when the body of a fastener rests flatwise upon the upper surface of plate E and one leg or end of the fastener engages or enters one of the series of slots or passages N the other leg or end of the fastener will enter the next adjacent slot or passage N, thereby permitting the fastener to pass from the hopper, the body thereof passing through the space M and the legs thereof passing either successively through the same slot N or else one leg pass-

ing through one slot N and the other leg passing through the next slot or passage N. Preferably the lower edge of the casing F is of a thickness corresponding to the diametrical dimension of a fastener, whereby only one fastener at a time may be held with both its legs in the same slot N or with one of its legs in one slot and the other in the next adjacent slot; but such fastener will be retained in this position without danger of being displaced therefrom by the other fasteners contained in the hopper until the particular slots or passages in which the fastener legs or ends are received are brought into register with the receiving mouth or passage of the raceway, presently to be more fully described. When this position is attained, the fastener passes from the hopper, thus making room for another fastener to enter. Preferably and in order to facilitate the ready and easy passage of the fasteners from the hopper the slots or passages N radiate from the center of the hopper and preferably increase in area from the inner surface of said casing outwardly toward the outer surface thereof, as clearly indicated at O, Fig. 3. By this construction a hopper is produced from which the fasteners may pass readily and easily and without danger of choking or forming an obstruction. The upturned circular flange of support E is provided with an opening or passage (indicated at P, Figs. 3 and 4) arranged at a point opposite the lowest part of the hopper when held in its inclined position, whereby when the slots or passages N are brought into register therewith the fasteners may readily pass through and from the hopper. A chute or raceway suitably constructed and slotted, as will presently be more specifically described, is arranged with the mouth thereof communicating or registering with the opening or passage P, as clearly shown in Figs. 3 and 4. Suitably supported upon plate E, adjacent to the lower edge of the hopper, is a chamber Q, in which is mounted a disk R, having a roughened or grooved upper surface. The disk R is arranged with its upper surface flush or in the same plane with the upper surface of plate E and also of the bottom of the feed-chute or raceway and is arranged to project partially within the lower edge of the hopper and also partially within to form part of the feed-chute or raceway. By imparting movement to this disk R the passage of the fasteners from the hopper and the starting of the same down the feed-chute or raceway are facilitated and rendered more certain and positive.

As above explained, the hopper is arranged upon an incline, whereby the fasteners contained therein may gravitate toward the lower part thereof, whereby the legs thereof may enter the slots or passages N and the bodies thereof may enter the space M. In order to still further insure a lodgment of the fasteners in such slots or passages and open space, said hopper F may be made movable. This movement may be either a rocking movement

or a rotation. In the particular form shown, to which, however, I do not desire to be limited, said hopper or casing F is rotated. Many specifically-different arrangements of mechanism for rotating the hopper may be devised, and while, therefore, I have shown and will now describe a specific construction and arrangement of mechanism for accomplishing this purpose I do not desire to be limited or restricted thereto.

Suitably journaled in an arm or other suitable part of framework A is a shaft S, Fig. 4, upon which is mounted to revolve loosely a pulley T. This pulley may receive rotation through any suitable arrangement of gearing from the main drive-shaft—as, for instance, through a belt 16, arranged to pass around and to be driven by a pulley 17, mounted on a counter-shaft rotated from main shaft B by means of the intermeshing gears 18 19. In the particular arrangement shown belt 16 passes from pulley 17 over a guide-pulley 20, thence in an open bight around the driving-pulley of the hopper on one side of the machine, thence around a guide 21 and in a crossed bight around pulley T, and thence over a guide 22 to pulley 17. By this arrangement the hoppers on opposite sides of the machine are rotated in opposite directions. In order that the operation of the hoppers may be controlled, provision is made for throwing the hopper into or out of action at will, and to this end the arrangement is such that normally the hopper is out of action. This result is secured by mounting pulley T upon shaft S to revolve loosely thereon, and a clutch or other suitable engaging arrangement is provided for coupling said pulley and shaft to rotate together. I have shown a specific form of clutch wherein a pin 24, having its projecting ends secured in a clutch-sleeve 25, (see Figs. 4 and 5,) is arranged to pass transversely through an opening (indicated at 23) through shaft S. This opening or slot 23 is somewhat elongated in the direction of length of said shaft, whereby the clutch sleeve or collar 25 and the pin 24 carried thereby may have a range of play or movement lengthwise of said shaft. This clutch-sleeve 25 is provided with a series of seats or teeth forming shoulders 26. (See Fig. 5.) Suitably secured to pulley T is a plate 27, arranged to engage a shoulder or tooth 26 of the clutch-sleeve 25 when said sleeve is moved into proper position therefor, thereby locking pulley T and shaft S to rotate together. The engagement or disengagement of sleeve 25 with detent or plate 27 may be effected in many different ways. In the particular form shown, to which, however, my invention is not limited, a rod 28 is arranged to extend longitudinally through the bore of shaft S, said shaft being hollow, and pin 24 of the clutch-collar 25 is arranged to pass transversely through an opening or passage in said rod 28. A spring 29 is arranged to normally maintain rod 28 in position to hold clutch-sleeve 25 out of engage-

ment with plate or detent 27. Rod 28 may be projected endwise against the action of spring 29 and in a direction to cause plate 27 to engage behind a shoulder or tooth 26 of the clutch-collar in any suitable manner, as by means of a handle or lever 30, pivotally secured to the framework and adapted to engage said rod.

By providing the clutch-collar 25 with a number of teeth or shoulders 26 it will be seen that by projecting rod 28 endwise to carry said collar into position for plate or detent 27 to engage a shoulder or tooth thereon such engagement is effected at once and without material loss of time, as such clutch-collar is required to rotate in any event only through a short arc in order to bring the detent or plate 27 into alinement with the engaging surface of a tooth of the clutch-collar. Hopper F is secured to rotate with shaft S in any suitable manner—as, for instance, by means of a rod 31, passing transversely through said shaft and connected at the ends thereof with said hopper.

From the foregoing description it will be seen that the hopper is normally out of rotative or movable action; but by suitably manipulating lever 30 pulley T is clutched to effect a rotation of shaft S, thereby rotating the hopper.

While I have shown and described a specific construction of hopper whereby the fasteners are enabled to pass therefrom, specific claim to such specific construction of hopper is not made herein, as the specific construction of the hopper is the joint invention of myself and E. D. Heinemann and forms the subject-matter of specific claims in the companion application above referred to. However, the specific construction and arrangement of means for rotating said hopper which I have just described are of my sole invention and will be specifically claimed herein.

I have indicated in the foregoing description that disk R, which is arranged to form a portion of the bottom of the chute or raceway and also flush with the top surface of plate E and arranged to project slightly within the hopper at its lower point, is movable in order to insure and facilitate the passage of the fasteners from the hopper into the chute or raceway. This movement may be either a rocking movement or (and preferably) a rotation, which may be secured in any suitable manner—as, for instance, by means of a belt 32, passing around a pulley 33 on shaft 34, upon which said disk is mounted. This belt passes around a guide-pulley 35 and over a driving-pulley 36 on main shaft D. By this construction it will be seen that a continuous rotation is imparted to disk R, and since said disk forms a part of the bottom of the upper end of the chute or raceway and also projects slightly into the hopper, with its top surface flush or contained in the same plane with the bottom of the hopper, and also forms the bottom of the passage P, it will be readily

seen that the fasteners are insured a passage and delivery from the hopper to the raceway whenever the slots or passages N containing the legs thereof are brought over said disk R and into register with passage P through the upturned flange of plate E. The arrow in Fig. 3 indicates the direction of rotation of disk R.

It sometimes happens that a fastener passes from the hopper with the wrong leg thereof in advance—that is to say, it is necessary to present the fasteners in absolutely uniform position to the action of the setting mechanism—and since the legs of a fastener are contained in a plane which intersects the body of the fastener to one side of the diameter thereof it is necessary in order to secure the desired uniformity of feed and delivery of the fasteners that they be always delivered into the feed-chute or raceway so that the plane containing the legs of each fastener will be on the same side of the parallel plane containing the diameter of the body of said fastener. Therefore it is necessary to provide means whereby in the event a fastener passes from the hopper with the wrong leg in advance—that is, with the plane containing the legs of the fastener on the left-hand side, as viewed in Fig. 6, of the parallel plane containing the diameter of the body of the fastener—it may be turned around side for side, so that it may pass down the chute or raceway uniformly. To accomplish this result, the slot or opening at the upper end of the chute or raceway is provided with a projecting lip 38 (see Fig. 3) in one wall thereof and a corresponding or cooperating projection 38' in the opposite wall thereof, the two projections 38 38' forming a contraction in the area of the opening of such slot to a point just enabling a leg of a fastener to pass singly therebetween. Immediately below the projecting lip 38 is a notch or recess 37 in the wall of such slot, which notch or recess, together with a corresponding and cooperating depression 37' in the opposed wall or edge of the slot, forms an enlargement in the slot in the feed-chute or raceway of an area adapting a fastener to be turned axially therein. The disk R forms a movable bottom for the feed-chute at these points. The operation is as follows: In case a fastener is delivered into the upper end of the raceway with the proper leg foremost the fastener will be swept or carried down the raceway by the accelerating feed-disk R until the narrow channel between projecting lips 38 38' is reached. These projecting lips are so relatively arranged with respect to the underlying chamber of the raceway, which receives the body of the fastener, that if the fastener is in its proper position the legs thereof will readily and successively pass through such contracted channel between said lips and will pass on in this same position through the enlargement in said passage formed by the notches or depressions 37 37' and deliver into chamber 39 of the feed-chute or raceway,

a slot 40 of which is in alinement with the contracted opening between lips 38 38', and through which slot 40 the legs of the fastener project. If, however, the wrong leg of a fastener is foremost when the fastener reaches the contracted portion of slot 40 between lips 38 38', it will slightly tilt to permit the foremost leg to pass through such contracted passage, and the lip 38 will form a detent for the rear leg thereof, whereupon gravity or the movement of plate R will cause the foremost leg after it passes through the contracted opening to tilt or swing in the opposite direction around said lip and into the seat or depression 37, thereby permitting the rear or hindmost leg to pass through the contracted passage and to swing around into position to be the foremost or leading leg, thereby enabling the fastener to proceed properly and in the proper manner down the chute or raceway. It will be seen that since the fastener passes from the hopper directly into the feed-chute, if started in the proper manner in the first instance, the particular arrangement just described operates only when the fastener passes from the hopper in an improper position.

The feed-chute or raceway is most clearly shown in dotted lines in Fig. 3 and in transverse section in Fig. 6 and comprises a chamber 39 of a depth and width corresponding to the size of the body portion of a fastener and having a slot 40, through which the legs of the fastener project. In order to accommodate the particular form of fastener shown, the slot 40 is arranged somewhat to one side of the central line of chamber 39, so that the larger portion J of the body of the fastener lies on one side and the smaller portion L on the other side. In other words, and as clearly indicated in dotted lines in Fig. 3, that portion of chamber 39 which receives the portion J of the fastener and which lies on one side of slot 40 is of greater area than the other side of the chamber 39 which receives the portion L of the body of the fastener. Therefore unless the fastener is delivered in a proper manner to the raceway it cannot enter or be fed down the chute or raceway. It will also be seen that the fastener is delivered from the hopper with the ends K thereof projecting upwardly. In order that these ends may be inverted when presented to the action of the setting-dies, the raceway (indicated generally at W) is reversely bent or curved upon itself, as clearly shown in Fig. 1; but specific claim thereto is not made herein, as the subject-matter thereof is covered specifically in the claims of the joint application above referred to.

From the foregoing description it will be seen that the fasteners are delivered into the raceway in single column. However, it sometimes occurs that the fasteners are delivered to the raceway more rapidly than they are delivered from the lower or delivery end of the raceway. In such event the raceway becomes filled with fasteners and a choke is liable to

occur. In order to prevent and avoid this objection, it is desirable to provide means for automatically arresting the feeding of the fasteners when the raceway becomes filled. Many specifically different arrangements may be devised for accomplishing this purpose and still fall within the spirit and scope of my invention. I do not desire, therefore, to be limited or restricted to the exact details of construction and arrangement now to be described. In the form shown, particular reference being had to Figs. 1, 2, 14, 15, and 16, a wheel 41, having projecting pins 42, is mounted to rotate in such relative position and relation as to permit the pins 42 to project through an opening in raceway W and into chamber 39 of said raceway, so that said pins engage the column of fasteners in case the raceway becomes filled, whereby rotation of said wheel 41 is arrested. Upon shaft 43, carrying said wheel, is mounted a peculiarly-shaped spiral gear 44, having grooves cut in the periphery thereof and extending somewhat spirally with respect to the axis of rotation of said gear. Arranged to mesh with this gear 44 is a worm 45, mounted on a longitudinally-movable shaft 46, suitably journaled in a fixed sleeve 47 to rotate therein, but capable of longitudinal movement therethrough. A pulley 48 is suitably coupled to rotate with shaft 46, but permitting said shaft to move longitudinally through said pulley. This is accomplished by means of a pin 48', having its ends secured to a flange formed with pulley 48 and arranged to project transversely through a slot 47' in shaft 46, said slot being elongated in the direction of length of said shaft. From this construction it will be seen that shaft 46 is always coupled to pulley 48 and rotates therewith, but slot 47' enables said shaft 46 to be moved endwise relative to said pulley. Upon shaft or rod 46 is mounted a collar 49, and a spring 50 is interposed between said collar and the end of sleeve or casing 47, the normal action of said spring being to maintain shaft 46 in one limit of its longitudinal movement. Pivotaly mounted upon a fixed part of the framework is a lever 52, (see Fig. 1,) through the upper end of which shaft 46 is arranged to project, the collar 49 being arranged on one side of said lever 52 and a head 51 on the end of shaft 46 being on the other side of said lever. The lower end of said lever is formed into a hook 53, forming a retaining-guide for lever 30. Formed on lever 52 is a hook or shoulder 54, operating as a retainer for lever 30 when said lever is rocked into position to establish engagement between driving-pulley T and hopper F, a slight spring 55 serving to hold said shoulder 54 in position to engage lever 30. Continuous rotation is imparted to shaft 46 by means of a belt 56, driven from pulley 33 and passing over pulley 48. The operation of this part of the apparatus is as follows: Rotation is imparted to the main drive-shaft. The attendant then rocks lever 30 into posi-

tion to be engaged by shoulder 54 of lever 52. This causes pulley T to be clutched with shaft S, and hence sets in rotation hopper F. The fasteners are thus delivered singly into raceway W. By reason of the intermeshing of worm 45 and gear 44 pin-wheel 41 is rotated, the ends of the pins 42 describing a path which projects into the raceway. In case the feed-chute or raceway W becomes filled with fasteners to a point where a pin 42 on wheel 41 engages the top of the column thereof, the rotation of said wheel, and hence also of its supporting-shaft and spiral gear 44, is arrested. Thereupon said gear 44 operates as a stationary screw-block with respect to worm 45, which is continuously rotating, and hence said worm 45, and also shaft 46, is drawn longitudinally until the teeth or slots which form the engagement between gear 44 and worm 45 are cleared by worm 45, as indicated in Fig. 15. This longitudinal movement of shaft 46 is against the action of spring 50, the action of which normally tends to return worm 45 into rotative engagement with the gear-slots of gear 44. The longitudinal movement of shaft 46, as above mentioned, causes the head 51 on the end thereof to engage lever 52 and rock the same against the action of its spring 55, and in a direction to carry shoulder 54, formed thereon, clear or out of engaging position with reference to lever 30, thereby releasing said lever and permitting the same to drop. Thereupon spring 29 will cause rod 28 to be returned to its normal position, such movement being endwise and in a direction to cause clutch-sleeve 25 to become disengaged from plate or tooth 27, thereby arresting the rotation of the feed-hopper, and hence arresting the further feed of the fasteners. This relation of the parts is maintained until pin-wheel 41 is again permitted to rotate—that is, until the fasteners are delivered in sufficient numbers from the lower end of the raceway to cause the top of the column to descend sufficiently for the ends of the pins 42 to be cleared, thereby releasing said pin-wheel and permitting the same to rotate freely. Thereupon spring 50 operates to return shaft 46 to its initial position, with worm 45 intermeshing with gear 44, as shown in Fig. 14. This movement, however, does not result in starting up the hopper, and therefore a feeding of the fasteners from the hopper will not be resumed. Such resumption can only be accomplished by the attendant again rocking lever 30, thereby causing pulley T to be clutched to shaft S, and when said lever 30 is rocked into position to be retained by shoulder 54 the delivery of the fasteners from the hopper is resumed. Moreover, the tendency of spring 50 to return shaft 46 to the position thereof indicated in Fig. 14 is opposed by shoulder 49 bearing against the side of lever 52, and it is only when lever 30 is raised into position to be engaged by shoulder 54 that the force of said spring is exerted

to accomplish the endwise movement of shaft 46, as described.

I will now describe a specific construction and arrangement of fastener delivering, setting, and clenching mechanism, to which, however, I do not desire to be limited. In the form shown, V designates a casing in which the plungers are arranged to operate. As shown in Fig. 7 and in detail in Fig. 9, the plunger is formed in two separate parts 57 58, the part 58 forming the setting-plunger proper and the part 57 forming the operating part of the plunger. Each of these parts of the plunger is bifurcated or forked in the end thereof, the bifurcation or fork being formed by removing a longitudinal segment from diametrically opposite sides thereof, as clearly shown in Figs. 8 and 9. The fork of one portion of the plunger is arranged to normally straddle and work in the fork of the other section of the plunger. The section 57 of the plunger is connected to a plunger-head 59, suitably reciprocated from a crank-pin 60 on a disk 61, mounted on and rotating with main shaft B through a connecting-link 62. (See Fig. 1.) Thus continuous reciprocation is imparted to the portion 57 of the plunger. The normal position of the upper end of part 58 of the plunger is such that the reciprocating part 57 works freely thereon; but at the upper limit of each reciprocation the lower end of said upper part 57 clears the upper end of the lower part 58. An arm 63 is connected to the lower part 58 of the plunger, said arm projecting through a slot or opening 64 in casing V. To said arm is pivotally connected the free end of a rod 65, said rod being pivotally connected at its other end to a crank-arm 66, loosely sleeved upon a short shaft, (indicated in dotted lines at 66', Fig. 13.) Rigidly mounted upon to rock with said shaft 66 is a second crank-arm 65', to the end of which is yieldingly connected a rod 67 through spring 68. By suitably projecting rod 67 endwise, as by means of a foot-treadle, (not shown,) shaft 66' is rocked, and by suitably clutching crank-arm 66 to rock with said shaft bar 65 is drawn endwise, thus rotating the lower section 58 of the plunger. Of course this rotation of said lower part of the plunger is not permitted, although an endwise tension is imposed on rod 67 until the lower end of the upper section 57 of the plunger is freed from engagement with the upper end of the lower portion 58 of said plunger. Therefore it is not necessary that rod 67 be projected endwise only when such disengagement takes place, for it is obvious that an endwise tension imposed upon rod 67 by the operator will be taken up in spring 68; but such tension will not be operative to effect a rocking of portion 58 of the plunger until it is disengaged from portion 57; but the moment such disengagement takes place a partial axial rotation of portion 58 of the plunger is accomplished. A spring 69, connected

at one end to the frame and at the other end to crank 67, serves to normally maintain portion 58 of the plunger in position for the portion 57 to straddle and reciprocate telescopically thereon. When, however, the lower section 58 of the plunger is partially rotated, as above explained, the ends of the solid segments of the bifurcation or fork of section 57 of the plunger are brought into alinement with the ends of the solid portions or segments of the fork of section 58 of the plunger. Thereafter the downward reciprocation of the portion 57 of the plunger pushes the portion 58 of the plunger downwardly before it. The groove 64 in the casing and through which arm 63 projects is so shaped, as shown in Fig. 13, as to permit the downward movement of the portion 58, but prevents relative rotation of said portion during such downward movement after it has once been rotated into position to cause the abutment above referred to. In other words, said slot 64 is similar to a bayonet-joint, one end thereof being turned or bent away from the main portion to permit the axial rotation of the portion 58, but preventing endwise movement thereof, the other portion of the slot permitting endwise movement of said section of the plunger, but preventing rotation thereof. A spring 70, connected at one end to bar 65, serves to normally elevate or return plunger 58 to its upper limit, and said spring 70, in conjunction with spring 69, serves to return said portion 58 to its initial or normal position to be straddled by the forks or bifurcations in the end of the upper section 57 of the plunger, thereby permitting said upper section of the plunger to slide freely thereon.

The downward movement of the plunger above described serves to insert a fastener, which has previously been placed in position in line therewith, in the material to which the fastener is to be applied and, in conjunction with the anvil or die, to clench the ends of the fastener on the under side of such article. I have described the crank-arm 66 as loosely sleeved upon shaft 66', but may be clutched to rock therewith. This clutching may be effected in many different ways. I have shown a simple arrangement for accomplishing this purpose, to which, however, I do not desire to be limited, and wherein said crank-arm 66 is provided with a perforation in the sleeve thereof, into which a pin (indicated in dotted lines at 70') may be arranged to project, said pin being carried by a piece 69', connected to rotate with shaft 66', but yieldingly mounted, so as to be moved in a direction to disengage pin 70' from engagement with the sleeve or hub of crank-arm 66. In an apparatus embodying the duplicated arrangement, as above described, on opposite sides of the machine this arrangement of coupling the crank-arms 66 or uncoupling the same is desirable and important, for the reason that thereby the plunger on either side of the machine may be readily and easily thrown out of action

when desired or both may be coupled to operate in unison when required.

I will now describe the holder for the fastener and upon which the fastener is delivered from the raceway and is held and retained in line with the plunger; but I make no claim herein to the specific construction of such holding and retaining means, as the same is claimed specifically in the joint application referred to.

Referring to Figs. 7, 8, 10, 11, and 13, reference-sign 72 designates a bar or rod mounted to slide in a seat formed in head V. A spring 73, arranged to rest at one end upon a pin 71, fixed in head V, bears at the other end against the upper end or wall of a slot 71', formed in said rod or bar 72 and normally but yieldingly maintains said bar in elevated position. Upon the lower end of said bar are pivotally mounted plates 74 75, each provided with a wing or projection 76 and also with an angularly-projecting plate 77. The plates 74 75 are held slightly separated from each other by means of a projection 78 on the lower end of arm 72, said projection entering the space between the angularly-projecting portions or plates 77, as shown in Fig. 11. The spring 79 normally operates to press the angular projections 77 toward each other. The space between the angular projections 77 is just sufficient to receive therein the legs of a fastener, the body portion of the fastener resting upon the upper surface of said plates or projections. These angular plates or projections 77 are arranged in position to support a fastener in alinement with the plunger 58, the projection 78 also serving as a stop, against which the coil of the body portion of the fastener rests. When the plunger is operated endwise, as above explained, the lower end thereof first engages the upper surface of the body of the fastener. The continued projection or endwise movement of section 58 of the plunger carries downwardly with it the arm or bar 72 against the action of spring 73. In the path of downward movement of plates 74 75 are arranged fixed arms or fingers 80 in position to engage the projecting wings 76 of said plates 74 75, thereby rocking said plates about their pivots against the action of spring 79, thus causing the angular projections 77 to separate, and hence releasing the fastener and permitting it to pass between such angular projections. The parts are so relatively arranged, however, that this separation does not occur until the ends of the fastener have been inserted in the material sufficiently to obtain a firm hold thereon.

It is important that upon each downward reciprocation or movement of the plunger 58 a fastener be certainly and positively deposited or delivered upon the supporting angular projections 77 in order that the machine may not miss setting a fastener upon each downward action of plunger-section 58. In order to accomplish this result, I have shown and will now describe a specific construction and

arrangement; but I do not desire to be limited or restricted to the exact details shown and described, as many variations therefrom may readily suggest themselves to persons skilled in the art and still fall within the spirit and scope of the invention. In the form shown I provide adjacent to the lower or delivery end of the raceway W a guide 81, in which slides a bar 82, the sliding movement thereof being suitably resisted, as, for instance, by means of a spring 83, the tension of which may be regulated by set-nut 84. Rod 82 is pivotally connected at its lower end to the angle of an angle-lever 85, which is provided at its free end with a foot 86, serrated or roughened on its under surface and arranged to project through a slot or opening in raceway W in position to engage the top surface of the fasteners. In a fixed bracket 87 is journaled a rock-shaft 88, upon one end of which is mounted an arm 89, loosely pivoted to one of the arms of crank-lever 85, as by means of a slot-and-pin connection, (indicated at 90, Fig. 7.) Upon the other end of rock shaft or pin 88 is mounted an arm 91, arranged to project into the path of movement a convenient reciprocating or movable part of the apparatus which moves with the plunger-section 58—such, for instance, as arm 65. (See Figs. 7 and 8.) The rocking of rock-shaft or pin 88, is opposed by means of a spring 92. The operation of this part of the apparatus is as follows: Upon each downward reciprocation of portion 58 of the plunger arm 65 engages arm 91 and rocks the same, and with it rock-shaft 88 and arm 89, in the direction indicated by the arrow, Fig. 7, and against the action of spring 92. This movement of arm 89 through its pivotal and loose connection with the angle-arm 85 first rocks the said angle-arm about its pivotal connection with bar 82, which rocking movement is continued until lug or heel projection 93, formed on said angle-arm, engages said bar 82 as a stop. This rocking movement of angle-arm 85 raises foot 86 out of engagement with the fastener. After a lug or projection 93 has engaged bar 82, whereby angle-arm 85 can no longer rock about its pivotal connection with bar 82, the continued rocking movement of bar 89 projects bar 82 endwise into casing 81, carrying with it angle-arm 85, with the foot 86 thereof still elevated. This operation takes place during the action of the plunger-section 58 in effecting an insertion of the fastener previously deposited upon the retaining plates or flanges 77. When plunger 58 is again elevated or returned to its upper limit of movement, bar 65 releases arm 91, whereupon spring 92 returns shaft 88 and arm 89 to their normal and initial positions. The first result of such return movement is to cause angle-arm 85 to rock about its pivotal connection with bar 82 and into position for the foot 86 thereof to engage upon the top surface of the next fastener. Thereafter the continued swinging movement of arm 89 causes bar 82 to be withdrawn endwise from

casing 81, carrying in advance thereof the angle-arm 85, thereby positively pushing the fastener engaged by the under roughened surface of foot 86 and delivering the same positively from the lower end of the raceway and upon the retaining plates or flanges 77 and into position in alinement with plunger 58. The foot 86 serves thereafter to hold the fastener in this position and against the projection 78, as above explained, as a stop until the plunger again begins its descent, and thereupon the foot 86 is first raised out of engagement with the fastener and then withdrawn, as above explained, and without disturbing the position occupied by the fastener.

In line with the plunger-section 58 and arranged to cooperate therewith is a setting-die or anvil 94, (see Fig. 12,) suitably and adjustably mounted in a fixed block 95, forming part of the framework. The die or anvil 94 may be vertically adjusted by means of screw 97 and held in adjusted position by set-screw 96. A plate 98, having a central opening, as at 99, through which the top surface of die or anvil 94 is arranged to pass, is supported on the bed plate or block 95 and is provided with upturned flanges 100, arranged, preferably, in right-angular relation with respect to each other, thereby forming retaining flanges or guides for the article to which the fasteners are to be applied. By this construction it will be seen that uniformity in attaching fasteners to articles is secured—that is, the article is held thereby in uniform relation to the setting-plunger when in position to receive a fastener.

From the foregoing description it will be seen that I provide an exceedingly simple and efficient apparatus for automatically feeding, inserting, and setting lace-fasteners, the operation of which will be readily understood from the foregoing description, taken in connection with the accompanying drawings.

Having now set forth the object and nature of my invention and an apparatus embodying the same and having described the construction, function, and mode of operation thereof, what I claim as new and useful and of my own invention, and desire to secure by Letters Patent, is—

1. In an automatic machine for feeding and inserting lace-fasteners, a main drive-shaft, a feed-hopper comprising a stationary base-plate and a cylindrical casing rotarily supported thereon, an auxiliary shaft, said casing connected to rotate with said auxiliary shaft, a pulley loosely mounted upon to rotate with said auxiliary shaft, gearing for continuously rotating said pulley from the main drive-shaft, and a movable clutch for engaging and disengaging said pulley and auxiliary shaft, as and for the purpose set forth.

2. In an automatic machine for feeding and inserting lace-fasteners, a main drive-shaft, an auxiliary shaft, a feed-hopper comprising a stationary base-plate and a cylindrical casing, said casing mounted upon to rotate with

said auxiliary shaft, a pulley loosely mounted to revolve upon said auxiliary shaft, gearing for continuously driving said pulley from the main shaft, a tooth or plate carried by said pulley, and a clutch-collar mounted upon to rotate with said auxiliary shaft and capable of movement thereon to engage said tooth, whereby said pulley is clutched to rotate with said shaft, as and for the purpose set forth.

3. In an automatic machine for feeding and inserting lace-fasteners, a main drive-shaft, a feed-hopper, a hollow auxiliary shaft, said hopper mounted upon to rotate with said auxiliary shaft, said hollow shaft being normally inactive, a pulley loosely mounted to rotate freely upon said hollow shaft, gearing for continuously driving said pulley from the main shaft, a rod mounted longitudinally in said hollow shaft and adapted to be projected endwise, and a clutch actuated by the movements of said rod for effecting an engagement between said pulley and hollow shaft, as and for the purpose set forth.

4. In an automatic machine for feeding and inserting lace-fasteners, a main drive-shaft, a feed-hopper, a hollow auxiliary shaft, said hopper mounted upon to rotate with said auxiliary shaft, a rod longitudinally mounted in the bore of said hollow shaft and capable of longitudinal movement therein, means for yieldingly maintaining said rod in one limit of its movement, a clutch-collar connected to move with said rod and having a plurality of teeth or shoulders, a drive-pulley loosely mounted to rotate freely upon said hollow auxiliary shaft, a plate carried by said pulley, adapted to engage with a tooth or shoulder of said collar when the latter is moved, whereby said pulley is clutched to drive said shaft, and means for continuously rotating said pulley from the main drive-shaft, as and for the purpose set forth.

5. In an automatic machine for inserting and setting lace-fasteners, a main drive-shaft, a feed-hopper, a hollow auxiliary shaft, said hopper mounted upon to rotate with said auxiliary shaft, a pulley loosely mounted to rotate freely upon said auxiliary shaft, said auxiliary shaft provided with an elongated transverse perforation, a clutch-sleeve having a pin arranged to pass through such perforation and provided with a plurality of teeth or shoulders, a detent or plate carried by said pulley, a rod mounted in said hollow shaft, said clutch-collar pin also passing through said rod, said rod when projected adapted to move said clutch-collar into position for said plate or detent to engage a tooth or shoulder on such clutch-collar, and means for continuously rotating said pulley from the main drive-shaft, as and for the purpose set forth.

6. In an automatic machine for feeding and inserting lace-fasteners, a feed-hopper, a raceway communicating therewith and a disk arranged to project slightly within said hopper and forming a portion of the bottom of said

raceway, and means for moving said disk, as and for the purpose set forth.

7. In an automatic machine for feeding and inserting lace-fasteners, a hopper, a raceway communicating therewith, a disk having a roughened upper surface and arranged to project slightly within said hopper flush with the top surface of the bottom thereof, said disk forming a portion of the bottom of said raceway, and means for rotating said disk, as and for the purpose set forth.

8. In an automatic machine for feeding and inserting lace-fasteners, a rotating feed-hopper having passages in the lower edge thereof, a raceway communicating with said hopper and adapted to receive the fasteners from said hopper through said passages, in combination with a disk having its edge arranged to project slightly within the hopper and flush with the bottom thereof, said disk forming a portion of the bottom of said raceway at the point of communication between said hopper and raceway, and means for rotating said disk, as and for the purpose set forth.

9. In an automatic machine for feeding and inserting lace-fasteners, a raceway comprising a chamber adapted to receive the body of the fastener, and a slot through which the ends of the fastener project, said slot provided in the edge thereof with a projecting lip, whereby the slot is contracted, and an enlarged lateral recess or notch adjacent to said lip and on the same side of the slot, whereby when a fastener enters said raceway in improper relation the rear leg thereof engages said lip to cause the front leg to enter said lateral notch or recess, thus axially rotating the fastener into proper position and permitting the rear leg of the fastener to be disengaged from said lip, as and for the purpose set forth.

10. In an automatic machine for feeding and inserting lace-fasteners, a raceway comprising a chamber and a slot to respectively receive the body and legs of the fastener, said slot being arranged slightly to one side of the central line of said chamber, said slot provided with a contracted portion, and a notch forming an enlargement whereby fasteners delivered to said raceway in wrong position are reversed or turned around into proper position, as and for the purpose set forth.

11. In an automatic machine for inserting and setting lace-fasteners, a hopper, a raceway communicating therewith, said raceway comprising a chamber adapted to receive the body of the fastener, and a slot through which the legs of the fastener are arranged to project, and projecting lips formed in the wall of said slot to contract the passage therebetween, said slot being formed straight in the line of said contracted passage, and a notch or recess arranged in the edge of said slot and forming an enlargement in said slot intermediate and adjacent to said contracted portion whereby fasteners entering the raceway in

improper position are automatically reversed or rotated into proper relation and said straight portion, as and for the purpose set forth.

5 12. In an automatic machine for feeding and inserting lace-fasteners, the combination with a hopper, a raceway communicating therewith and comprising a chamber and a slot respectively adapted to receive the body
10 and the legs of the fastener, said slot being contracted at one portion in the length thereof and enlarged at a point adjacent to said contracted portion, in combination with a disk arranged to form the bottom of said raceway
15 at such contracted and enlarged portions of the slot, and means for rotating said disk, as and for the purpose set forth.

13. In an automatic machine for feeding and inserting lace-fasteners, a feed-hopper, a
20 raceway communicating therewith, manually-actuated means for throwing said hopper into gear whereby the same is rotated, and means actuated by the filling up of said raceway for automatically arresting the rotation of said
25 hopper, as and for the purpose set forth.

14. In an automatic machine for inserting and setting lace-fasteners, a feed-hopper, gearing for rotating said hopper, said gearing being normally out of clutch with said hopper,
30 manually-actuated means for clutching said gearing to said hopper for actuating the same, and means for automatically arresting said gearing as and for the purpose set forth.

15. In an automatic machine for feeding and inserting lace-fasteners, a feed-hopper, a
35 raceway communicating therewith, gearing for actuating said hopper, said gearing being normally out of clutch with respect to said hopper, manually-actuated means for clutching
40 said gearing to said hopper, and automatic means arranged to operate when said raceway becomes filled with fasteners for unclutching said gearing from said hopper, as and for the purpose set forth.

16. In an automatic machine for feeding and inserting lace-fasteners, a feed-hopper, a
45 raceway communicating therewith, gearing for actuating said hopper, and means arranged to operate when said raceway becomes filled for automatically arresting the action of
50 said hopper, as and for the purpose set forth.

17. In an automatic machine for feeding and inserting lace-fasteners, a hopper, a raceway, means for delivering the fasteners from
55 said hopper to said raceway, and means arranged to operate only when said raceway becomes filled for automatically arresting the delivery of said fasteners from the hopper to said raceway, as and for the purpose set forth.

18. In a machine for automatically feeding and inserting lace-fasteners, a raceway, means
60 for delivering the fasteners to such raceway, a shaft, means for rotating said shaft, a spiral gear mounted on said shaft, a worm-block in which said spiral gear engages, said shaft being
65 longitudinally movable, and means for

arresting the rotation of said worm-block when the raceway becomes filled whereby said shaft is moved longitudinally, in combination with means actuated by the longitudinal
70 movement of said shaft for arresting the delivery of said fasteners to said raceway, as and for the purpose set forth.

19. In a machine for automatically feeding and inserting lace-fasteners, a feed-hopper,
75 means for actuating the same, a raceway communicating therewith, a wheel having pins arranged to project into said raceway, a worm-block mounted to rotate with said pin-wheel, a longitudinally-movable shaft having
80 a spiral gear arranged to mesh with said worm-block, means for rotating said shaft, and means actuated by the longitudinal movement of said shaft for arresting the action of said hopper, as and for the purpose set forth. 85

20. In an automatic machine for feeding and inserting lace-fasteners, a feed-hopper, means for actuating the same, a raceway communicating with said hopper, a wheel having
90 pins arranged to project into said hopper, a worm-block connected to rotate with said wheel, a shaft having a spiral gear thereon arranged to mesh with said worm-block, said shaft being longitudinally movable, means for rotating said shaft, a spring normally operating to maintain said shaft in one limit of
95 its movement, and means actuated by the longitudinal movement of said shaft in a direction opposed to the action of said spring for arresting the action of said hopper, as and for
100 the purpose set forth.

21. In an automatic machine for inserting and setting lace-fasteners, a feed-hopper, gearing for actuating said hopper, said gearing being normally out of clutch with said hopper,
105 manually-actuated means for clutching said gearing to said hopper, a retaining device for said actuating means, a raceway communicating with said hopper, and means actuated by the filling up of said raceway for moving
110 said retaining device out of engagement with said retaining means whereby said hopper is automatically unclutched, as and for the purpose set forth.

22. In an automatic machine for feeding
115 and inserting lace-fasteners, a feed-hopper, gearing for rotating the same, said gearing being normally unclutched from said hopper, a lever for effecting a clutching of said gearing to said hopper, a retaining-hook for said
120 lever, a raceway communicating with said hopper, and means actuated by the filling up of said raceway for automatically rocking said hook out of position to retain said lever, as and for the purpose set forth. 125

23. In an automatic machine for inserting and setting lace-fasteners, a plunger made in sections, said sections being bifurcated or
130 forked in the adjacent ends thereof, said bifurcations or forks normally arranged to straddle each other, one of said sections being normally held against endwise movement

means for reciprocating the other of said sections, and means for axially rotating one of said sections, as and for the purpose set forth.

24. In an automatic machine for inserting and setting lace-fasteners, a setting-plunger comprising two portions bifurcated or forked on the adjacent ends thereof, said forked ends normally arranged to straddle and telescope upon each other, one of said sections being normally held against endwise movement, means for reciprocating the other of said sections and means for partially rotating said normally-immovable section, whereby upon the reciprocation of one of said sections the ends of the forks thereof engage the ends of the forks of the other portion to project the same in advance thereof, as and for the purpose set forth.

25. In an automatic machine for inserting and setting lace-fasteners, a head or casing, a plunger mounted therein and comprising an upper and a lower portion disconnected from each other, said portions being forked in the ends thereof, said forks normally arranged to straddle each other, means for reciprocating said upper portion, said casing provided with a slot, an arm connected to said lower portion and projecting through said slot, a bar connected to said arm for partially rotating said lower section, means for moving said bar, and springs normally acting to retain said bar in normal position, as and for the purpose set forth.

26. In an automatic machine for inserting and setting lace-fasteners, a casing, a plunger mounted therein and comprising an upper and a lower portion, means for reciprocating said upper portion, said portions being forked on their adjacent ends, said forks normally arranged to straddle each other, said casing provided with a slot having a vertical straight portion and a horizontal curved portion, an arm connected to the lower portion of said plunger and projecting through and moving in said slot, and means connected to said arm for partially rotating said lower portion whereby it is engaged on the ends of the forked arms thereof by the ends of the forked arms of the upper portion of the plunger, whereby the lower portion of the plunger is projected endwise, said slot forming a guide to hold the same against rotation during such endwise projection, as and for the purpose set forth.

27. In an automatic machine for inserting and setting lace-fasteners, a slotted casing, a plunger mounted to operate therein and comprising an upper and a lower section, said sections being bifurcated or forked on the adjacent ends thereof, said bifurcations or forks normally straddling each other, means for reciprocating the upper section of said plunger, an arm connected to the lower section of the plunger and projecting through the slot in said casing, a rock-shaft, means for rocking the same, a crank-arm arranged to be connected to said shaft, and connections between

said crank-arm and the arm of said plunger-section whereby when said shaft is rocked said plunger-section is partially rotated, as and for the purpose set forth.

28. In an automatic machine for inserting and setting lace-fasteners, a casing, a pair of setting-plungers mounted to operate in said casing, a common drive mechanism for both plungers and means whereby either of said plungers may be made inoperative during the operation of the other of said plungers, in combination with means for delivering the fasteners separately to each of said plungers, and means whereby when either of said plungers is arrested the delivery of fasteners to such arrested plunger is also arrested, as and for the purpose set forth.

29. In an automatic machine for inserting and setting lace-fasteners, a casing, plungers mounted therein, means for reciprocating said plungers, a rock-shaft, crank-arms loosely sleeved thereon, means for rocking said shaft, connections between said crank-arms and said plungers for throwing the same into or out of operative relation, and independent means for coupling said crank-arms to said rock-shaft whereby said plungers may be coupled to operate in unison or any one of which may be thrown out of action during the action of the other, as and for the purpose set forth.

30. In an automatic machine for inserting and setting lace-fasteners, a plunger comprising an upper and a lower section, means for reciprocating said upper section, the adjacent ends of said sections being bifurcated or forked and normally arranged to straddle each other and said lower section normally held immovable, whereby said upper section telescopes or reciprocates upon said lower section, means for yieldingly imparting a rotative tension to said lower section whereby when the lower end of said upper section clears the upper end of said lower section said lower section is permitted a partial rotation to cause the ends of the forked arms thereof to be engaged by the ends of the forked arms of the upper section whereby said lower section is projected endwise, and means normally acting to return said lower section to its normal position, as and for the purpose set forth.

31. In an automatic machine for feeding and inserting lace-fasteners, a setting-plunger and a raceway and means for reciprocating said plunger, a feed-foot movably mounted upon the raceway at the delivery end thereof, a rock-shaft loosely connected to said feed-foot for raising, lowering and projecting the same, a crank-arm mounted on said shaft, said arm arranged to project into the path of the movable part of said plunger, whereby said feed-foot is actuated, as and for the purpose set forth.

32. In an automatic machine for feeding and inserting lace-fasteners, a setting-plunger, means arranged in the line of action thereof for receiving the fasteners, a race-

way, a guide mounted adjacent to the delivery end of said raceway, a rod mounted to slide in said guide, an angle-arm pivotally connected to said rod, said angle-arm provided with a foot arranged to engage the fasteners singly and deliver the same from said raceway, and means for rocking said angle-arm about its pivot, whereby said foot is raised from or lowered upon the fasteners, and means for reciprocating said bar whereby the fasteners are positively delivered from said raceway and into the line of action of said plunger, as and for the purpose set forth.

33. In an automatic machine for inserting and setting lace-fasteners, a plunger, means for actuating the same, a raceway, and means for delivering the fasteners positively from the end of said raceway into the line of action of said plunger comprising a sliding bar mounted upon said raceway adjacent to the delivery end thereof, an angle-arm pivotally mounted upon said bar and having a foot arranged to engage the fasteners singly, and means actuated by the downward reciprocation of said plunger for rocking said angle-arm about its pivot and for moving the bar endwise, as and for the purpose set forth.

34. In an automatic machine for inserting and setting lace-fasteners, a plunger, means for actuating the same, a raceway, a sliding bar an angle-arm pivotally mounted at the

angle thereof upon said bar and having a foot arranged to engage the fasteners, a rock-shaft having a crank-arm thereon loosely connected to one of the arms of said angle-bar, and means actuated by the downward movement of the plunger for rocking said shaft and projecting said bar, as and for the purpose set forth.

35. In an automatic machine for inserting and setting lace-fasteners, a plunger, means for actuating the same, a raceway, a longitudinally-movable bar mounted adjacent to the delivery end of said raceway, an angle-bar pivotally connected at the angle thereof to the end of said sliding bar, said angle-bar provided with a foot at its free end, a rock-shaft having a crank-arm loosely connected to the other arm of said angle-bar, a lug formed on said angle-bar and arranged to engage said sliding bar to form a stop therefor, and means arranged to be engaged upon a downward reciprocation of the plunger for rocking said shaft, as and for the purpose set forth.

In witness whereof I have hereunto set my hand, this 29th day of January, 1898, in the presence of the subscribing witnesses.

JOHN S. GOLDBERG.

Witnesses:

E. D. HEINEMANN,
S. E. DARBY.