

(19) World Intellectual Property Organization  
International Bureau



(43) International Publication Date  
22 June 2006 (22.06.2006)

PCT

(10) International Publication Number  
**WO 2006/064500 A2**

(51) International Patent Classification:  
**G02B 6/06** (2006.01)

(21) International Application Number:  
PCT/IL2005/001344

(22) International Filing Date:  
14 December 2005 (14.12.2005)

(25) Filing Language: English

(26) Publication Language: English

(30) Priority Data:  
60/635,510 14 December 2004 (14.12.2004) US

(71) Applicant (for all designated States except US): **OMS DISPLAYS LTD.** [IL/IL]; 2.3 High-Tech Village, Givat Ram Campus, P.O. Box 39158, 91391 Jerusalem (IL).

(72) Inventor; and

(75) Inventor/Applicant (for US only): **SHANI, Yosi** [IL/IL]; 747 Nachal Kishon, 71908 Maccabim (IL).

(74) Agent: **G.E. EHRLICH (1995) LTD.**; 11 Menachem Begin Street, 52 521 Ramat Gan (IL).

(81) Designated States (unless otherwise indicated, for every kind of national protection available): AE, AG, AL, AM, AT, AU, AZ, BA, BB, BG, BR, BW, BY, BZ, CA, CH, CN, CO, CR, CU, CZ, DE, DK, DM, DZ, EC, EE, EG, ES, FI, GB, GD, GE, GH, GM, HR, HU, ID, IL, IN, IS, JP, KE, KG, KM, KN, KP, KR, KZ, LC, LK, LR, LS, LT, LU, LV, LY, MA, MD, MG, MK, MN, MW, MX, MZ, NA, NG, NI, NO, NZ, OM, PG, PH, PL, PT, RO, RU, SC, SD, SE, SG, SK, SL, SM, SY, TJ, TM, TN, TR, TT, TZ, UA, UG, US, UZ, VC, VN, YU, ZA, ZM, ZW.

(84) Designated States (unless otherwise indicated, for every kind of regional protection available): ARIPO (BW, GH, GM, KE, LS, MW, MZ, NA, SD, SL, SZ, TZ, UG, ZM, ZW), Eurasian (AM, AZ, BY, KG, KZ, MD, RU, TJ, TM), European (AT, BE, BG, CH, CY, CZ, DE, DK, EE, ES, FI, FR, GB, GR, HU, IE, IS, IT, LT, LU, LV, MC, NL, PL, PT, RO, SE, SI, SK, TR), OAPI (BF, BJ, CF, CG, CI, CM, GA, GN, GQ, GW, ML, MR, NE, SN, TD, TG).

**Published:**

— without international search report and to be republished upon receipt of that report

For two-letter codes and other abbreviations, refer to the "Guidance Notes on Codes and Abbreviations" appearing at the beginning of each regular issue of the PCT Gazette.

(54) Title: DEVICE AND METHOD FOR OPTICAL RESIZING

(57) Abstract: An optical resizing device is disclosed. The device comprises a plurality of layers forming a substrate having a first facet and a second facet. Each layer of the plurality of layers having an arrangement of waveguides formed and/or embedded in the layer. In one embodiment, the layers are arranged in a partially overlapping optical arrangement such that each layer has an optically exposed region at the second facet. In another embodiment, the device comprises two optical resizing elements, each configured to provide optical expansion or contraction in one dimension, such that light propagating the device experiences two-dimensional optical resizing.



WO 2006/064500 A2

## DEVICE AND METHOD FOR OPTICAL RESIZING

FIELD AND BACKGROUND OF THE INVENTION

The present invention relates to optics and, more particularly, to a device and  
5 method for optical resizing.

Miniaturization of electronic devices has always been a continuing objective in  
the field of electronics. Electronic devices are often equipped with some form of  
display, which is visible to a user. As these devices reduce in size, their display size is  
reduced too. However, beyond some size the electronic device's display cannot be  
10 viewed with a naked eye and its image should be magnified.

An electronic display may provide a real image, the size of which is  
determined by the physical size of the display device, or a virtual image, the size of  
which may extend the dimensions of the display device.

Magnification of images produced by small size image display systems can be  
15 performed by projecting the image on a larger screen or via passive optical  
magnification element providing the user with a magnified virtual image. A virtual  
image is defined as an image, which cannot be projected onto a viewing surface, since  
no light ray connects the image and an observer.

It is appreciated, however, that the above magnification techniques are far from  
20 being optimal. Projected real images suffer from bulkiness since in projection the  
expansion of image is achieved by light propagation perpendicularly to the display.  
Devices producing virtual images have a limited field-of-view and are oftentimes also  
bulky.

In another magnification technique the image is not projected but rather guided  
25 through a bundle of optical fibers extending from a small facet to a large facet. The  
small facet is oftentimes referred to as "the object plane" whereas the larger facet is  
oftentimes referred to as "the image plane".

Referring now to the drawings, Figures 1-2 are schematic illustrations of  
several prior art techniques for manufacturing fiber base guided magnifiers.

30 Figures 1a shows an optical image transporting device based on the teachings  
of U.S. Patent No. 2,825,260. The magnification from the small facet to the large  
facet is achieved by increasing the separation between the fibers in the bundle. Figure  
1b illustrates a modification to this method, disclosed in U.S. Patent Nos. 2,992,587

and 3,853,658. In this technique, the fibers are up-tapered towards the large facet. These techniques, however, were not producible, due to the technological limitations associated with separation and up-tapering of optical fibers.

An attempt to overcome the up-tapering problem is disclosed in U.S. Patent No. 3,909,109, where an additional layer is added at the large facet. The thickness of the layer is selected such as to allow free propagation through the layer until the far field beams of the fibers overlap. This technique, however, suffers from a major limitation, because the Gaussian shape of the far field line makes it difficult to determine the optimal thickness of the additional layer.

Figure 1c shows another improvement of the device of Figure 1a which improvement is based on the teachings of U.S. Patent Nos. 3,043,910 and 4,208,096. In this improvement, the fiber separation is performed only in one dimension whereby the separation in the other (substantially orthogonal) dimension is done via by a terrace or slanted cut. In this configuration the fibers, after being separated in one direction, are redirected towards a large facet where they are terrace or slanted cut in order to be separated in the substantially orthogonal direction. A major limitation of this solution is the manufacturing difficulty.

Figures 2a-b show another technique for producing a fiber optic magnification element, according to the teachings of U.S. Patent Nos. 3,402,000 and 6,326,939. With reference to Figure 2a, a one-dimensional magnification element includes cylindrically shaped optical fibers which are cut in a manner such that a circular cross section is formed on one side and an elliptic cross section is formed on the other side. The circular cross section is perpendicular to the longitudinal axis of the cylinder, and therefore has the same diameter as the cylinder. The elliptic cross section is slanted with respect to the longitudinal axis, hence has a small axis which equals the diameter of the cylinder and a large axis which is larger than the diameter of the cylinder. When light is transmitted through the fibers from the circular side to the elliptic side, a one dimension magnification is established in the direction of the large axis of the elliptic cross section.

With reference to Figure 2b, two such one-dimensional magnification elements are connected via a redirecting layer such that the output of one element is used as the input of the other element. A second redirecting layer is used for coupling the light out of the second magnification element. To achieve proper optical coupling between

the first and second elements, the cross section of the fibers on the input side of the second element must have the same elliptic cross section of the fibers on the output side of the first element.

However, the elliptic input cross section of the second element's fibers cannot be obtained by slanted cut because the input cross section of the fibers must be perpendicular to their longitudinal axis. On the other hand, a fiber bundle with elliptically shaped fibers does not exist. Therefore, in order not to lose resolution at the second magnification, the number of fibers in the second element should be larger than the number of fibers in the first element, by a factor which equals the one dimensional magnification ratio of the first element. Additional drawbacks of this technique are the need for redirecting layers and the presence of non-guided light which can diminish the display aspect ratio.

U.S. Patent Nos. 5,511,141 and 5,600,751 disclose a reading magnifier formed by a bundle of juxtaposed longitudinally tapered optical fibers. The magnifier is commercially available under the trade name TaperMag™ from Taper Vision Co. Ltd., USA [E. Peli, W.P. Siegmund "Fiber-optic reading magnifiers for the visually impaired," *J Opt Soc Am A* 12(10): 2274-2285, 1995]. The TaperMag™, however, is bulky (thickness of about 5 cm for only ×2 magnification up to a 2 inches screen) because its thickness must be comparable to the size of facet diameter.

U.S. Patent No. 6,480,345 to Kawashima *et al.* discloses a magnifier which utilizes high-refractive-index regions extending from the small facet to the large facet. In simulations performed by Kawashima *et al.* it was found that a 30 inches magnifier can have a thickness of less than 4 cm and perform ten times enlargement. The manufacturing process of Kawashima's magnifier is, however, rather complicated. For example, one embodiment of Kawashima *et al.* involves the alignment of dozens of laminated thin plates produced by masks with increasing core dimensions. Another embodiment of Kawashima *et al.* involves three dimensions fiber handling. Although Kawashima *et al.* also teach simpler manufacturing processes, these are limited to magnification ratio of 2 or less.

There is thus a widely recognized need for, and it would be highly advantageous to have a device and method for optical resizing, devoid of the above limitations.

SUMMARY OF THE INVENTION

The background art does not teach the use of embedded waveguides to provide optical resizing. The present embodiments exploit the technology of embedded waveguides to provide optical resizing in one or two dimension.

5 Thus, according one aspect of the present invention there is provided an optical resizing device. The device comprises: a first optical resizing element having a plurality of waveguides designed and constructed to provide optical resizing in a first dimension; and a second optical resizing element, having a plurality of waveguides designed and constructed to provide optical resizing in a second dimension. The  
10 second optical resizing element is coupled to the first optical resizing element such that light exiting the first optical resizing element enters the second optical resizing element, hence being resized in both the first and the second dimensions. The waveguides of at least one of the first and second optical resizing elements are at least partially tapered.

15 According to further features in preferred embodiments of the invention described below, the plurality of waveguides of at least one of the first optical resizing element and the second optical resizing element are formed and/or embedded in a substrate in a longitudinally expanding arrangement such as to provide the optical resizing.

20 According to still further features in the described preferred embodiments the longitudinally expanding arrangement comprises layers of waveguides, each layer being arranged such that the waveguides extend from a first region of the layer to a second region of the layer thereby defining a circumferential boundary within the layer, wherein the length characterizing the circumferential boundary is smaller at the  
25 first region than at the second region, such as to provide the optical resizing.

According to another aspect of the present invention there is provided an optical resizing element. The optical resizing element comprises a plurality of layers forming a substrate having a first facet and a second facet being larger than the first facet. Each layer has an arrangement of substantially parallel waveguides formed  
30 and/or embedded in the layer and extending from a first region of the layer to a second region of the layer. In this aspect, the layers are arranged in a partially overlapping optical arrangement whereby the second region of each layer is optically exposed at the second facet such as to provide optical resizing in one dimension.

According to still another aspect of the present invention there is provided an optical resizing element. The optical resizing element comprises a substrate formed of at least one layer, each layer has an arrangement of waveguides formed and/or embedded in the layer and extending from a first region of the layer to a second region of the layer thereby defining a circumferential boundary within the layer. The length characterizing the circumferential boundary is smaller at the first region than at the second region, such as to provide optical resizing in one dimension.

According to further features in preferred embodiments of the invention described below, the first region and the second region are located at opposite sides of the layer.

According to still further features in the described preferred embodiments the first region and the second region are located at adjacent sides of the layer.

According to still further features in the described preferred embodiments first region and the second region are located at the same side of the layer.

According to still further features in the described preferred embodiments the first region and the second region are substantially parallel.

According to still further features in the described preferred embodiments the first region and the second region are substantially orthogonal.

According to still further features in the described preferred embodiments the first region and the second region are substantially collinear.

According to still further features in the described preferred embodiments at least one of the optical resizing elements comprises a slanted layer for providing the optical resizing.

According to still further features in the described preferred embodiments at least one of the optical resizing elements comprises a terrace for providing the optical resizing.

According to still further features in the described preferred embodiments at least one of the optical resizing elements is designed and constructed such that the light enters the optical resizing element while propagating in a first direction and exit the optical resizing element while propagating in the same direction.

According to still further features in the described preferred embodiments at least one of the optical resizing elements is designed and constructed such that the light enters the optical resizing element while propagating in a first direction and exit

the optical resizing element while propagating in a second direction being different from the first direction.

According to still further features in the described preferred embodiments the second facet is substantially parallel to the first facet.

5 According to still further features in the described preferred embodiments the second facet is substantially orthogonal to the first facet.

According to still further features in the described preferred embodiments the second facet is tilted with respect to the first facet.

10 According to still further features in the described preferred embodiments the second facet and the first facet are substantially coplanar.

According to still further features in the described preferred embodiments one optical resizing element is constructed and designed to receive light from a plurality of sources and transmitting the light into another optical resizing element.

15 According to still further features in the described preferred embodiments the device further comprises at least one additional optical resizing element which receives light from at least one additional light source and transmits the light into the second optical resizing element.

According to still further features in the described preferred embodiments the additional light source(s) comprises a monochrome light source.

20 According to still further features in the described preferred embodiments the optical resizing element being designed and constructed to emit light to a plurality of directions. The light can be originated from different sources, in which case each direction is attributed to a different source. The light can also be originated from a single source or another optical resizing element, in which case the same light is being  
25 emitted to a plurality of directions. For example, a single image can be formed on two different facets of the device.

30 According to still further features in the described preferred embodiments the device further comprises at least one additional optical resizing element positioned at one of the at least two different directions and configured to receive light from the first optical resizing element.

According to still further features in the described preferred embodiments at least one of the optical resizing elements comprises a plurality of partial optical

resizing elements whereby each partial optical resizing element is designed and constructed to provide partial optical resizing in a respective dimension.

According to still further features in the described preferred embodiments the device or optical resizing element further comprises a diffusive layer attached to or etched in the second facet.

According to still further features in the described preferred embodiments the device or optical resizing element further comprises an expanding structure.

According to still further features in the described preferred embodiments the expanding structure comprises a holographic optical element.

According to still further features in the described preferred embodiments the expanding structure comprises a stack of layers alternately patterned with high refractive index regions and low refractive index regions.

According to still further features in the described preferred embodiments the expanding structure comprises a stack of layers patterned with grooves.

According to still further features in the described preferred embodiments the expanding structure comprises a stack of layers of tapered waveguides.

According to still further features in the described preferred embodiments the expanding structure comprises mirrors. According to still further features in the described preferred embodiments the mirrors comprise total internal reflection mirrors.

According to still further features in the described preferred embodiments the mirrors are coated by high reflection coat.

According to still further features in the described preferred embodiments the expanding structure comprises Bragg reflectors.

According to still further features in the described preferred embodiments at least one optical resizing element is designed and constructed to polarize light.

According to an additional aspect of the present invention there is provided an optical resizing device. The device comprises a plurality of layers forming a substrate having a first facet and a second facet, the plurality of layers being arranged in a partially overlapping optical arrangement. Each layer has an arrangement of waveguides formed and/or embedded in the layer and extending from a first region of the layer to a second region of the layer thereby defining a circumferential boundary within the layer. The length characterizing the circumferential boundary is smaller at

the first region than at the second region, and the second region is optically exposed at the second facet.

According to further features in preferred embodiments of the invention described below, the first facet is defined by ends of overlapping regions of the plurality of layers.

According to still further features in the described preferred embodiments each layer is partially exposed at the first facet.

According to still further features in the described preferred embodiments at least a few layers comprise mirrors for redirecting light propagating within the plurality of waveguides out of the layer. According to still further features in the described preferred embodiments at least a portion of the mirrors are total internal reflection mirrors. According to still further features in the described preferred embodiments at least a portion of the mirrors are etched mirrors. According to still further features in the described preferred embodiments at least a portion of the mirrors are coated by a high reflective coat.

According to still further features in the described preferred embodiments at least a portion of the mirrors comprise planar facet.

According to still further features in the described preferred embodiments at least a portion of the mirrors comprise non-planar facet.

According to still further features in the described preferred embodiments at least a few layers comprise Bragg reflectors for redirecting light propagating within the plurality of waveguides out of the layer.

According to still further features in the described preferred embodiments at least a few layers comprise holographic optical elements for redirecting light propagating within the plurality of waveguides out of the layer.

According to still further features in the described preferred embodiments the device is characterized by a field-of-view selected sufficiently small so as to substantially preserve brightness of light being resized by the device.

According to yet an additional aspect of the present invention there is provided a method of manufacturing an optical resizing element. The method comprises: (a) forming on a substrate a plurality of waveguides in an expanding arrangement extending from a first region of the substrate to a second region of the substrate, thereby providing a layer of waveguides; (b) repeating the step (a) a plurality of times,

thereby providing a plurality of layers; and (c) stacking the plurality of layers so as to form a first facet, defined by ends of the plurality of layers, and a second facet, defined by an exposed surface of one of the plurality of layers; thereby manufacturing the optical resizing element.

5           According to still further features in the described preferred embodiments the method further comprises: (d) forming on a substrate a plurality of substantially parallel waveguides extending from a first region of the substrate to a second region of the substrate, thereby providing a layer of waveguides; (e) repeating the step (d) a plurality of times, thereby providing a plurality of layers; (f) stacking the plurality of  
10 layers in a partially overlapping optical arrangement whereby the second region of each layer is optically exposed, so as to form a first facet and a second facet, the second facet being defined by optically exposed portion of the plurality of layers; thereby manufacturing a second optical resizing element; and (g) optically coupling the optical resizing element to the second optical resizing element so as to allow  
15 propagation of light from the optical resizing element to the second optical resizing element, wherein the light is resized in a first dimension within the optical resizing element and in a second dimension within the second optical resizing element.

          According to still an additional aspect of the present invention there is provided a method of manufacturing a plurality of optical resizing elements. The  
20 method comprises: (a) forming on a substrate a plurality of waveguides extending from a first region of the substrate to a second region of the substrate, thereby providing a layer of waveguides; (b) repeating the step (a) a plurality of times, thereby providing a plurality of layers; (c) stacking the plurality of layers so as to provide a stack; and (d) performing at least one cut to the stack so as to provide a plurality of  
25 optical resizing elements.

          According to a further aspect of the present invention there is provided a method of manufacturing an optical resizing element. The method comprises: (a) forming on a substrate a plurality of parallel waveguides extending from a first region of the substrate to a second region of the substrate, thereby providing a layer of  
30 waveguides; (b) repeating the step (a) a plurality of times, thereby providing a plurality of layers; and (c) stacking the plurality of layers in a partially overlapping optical arrangement whereby the second region of each layer is optically exposed, so as to form a first facet and a second facet, the second facet being defined by optically

exposed portion of the plurality of layers; thereby manufacturing the optical resizing element.

According to still further features in the described preferred embodiments the method further comprises: (d) repeating the steps (b)-(c) so as to form a second optical  
5 resizing element; and (e) optically coupling the optical resizing element to the second optical resizing element so as to allow propagation of light from the optical resizing element to the second optical resizing element, wherein the light is resized in a first dimension within the optical resizing element and in a second dimension within the second optical resizing element.

10 According to yet a further aspect of the present invention there is provided a method of manufacturing an optical resizing device. The method comprises: (a) forming on a substrate a plurality of waveguides extending from a first region of the substrate to a second region of the substrate thereby defining a circumferential boundary within the substrate, wherein the length characterizing the circumferential  
15 boundary is smaller at the first region than at the second region; (b) repeating the step (a) a plurality of times, thereby providing a plurality of layers; and (c) stacking the plurality of layers in a partially overlapping optical arrangement whereby the second region of each layer is optically exposed, so as to form a first facet and a second facet, the second facet being defined by optically exposed portion of the plurality of layers,  
20 thereby manufacturing the optical resizing device.

According to still further features in the described preferred embodiments the method further comprises positioning mirrors for redirecting light propagating within the plurality of waveguides out of the substrate.

25 According to still further features in the described preferred embodiments the method further comprises cutting the layers, subsequently to the step of stacking the layers, so as to form at least one of the first facet and the second facet.

According to still further features in the described preferred embodiments the method the cutting is performed such that at least one facet is slanted.

30 According to still further features in the described preferred embodiments the method further comprises cutting the plurality of layers, prior to the step of stacking the layers, so as to form, for each layer, a layer end exposing a plurality of waveguides ends.

According to still further features in the described preferred embodiments the method further comprises depositing a polarizer on at least a portion of the layers, prior to the step of stacking the layers.

5 According to still further features in the described preferred embodiments the method further comprises coupling at least one facet to a coupler. According to still further features in the described preferred embodiments the coupler comprises a microlens array.

10 According to still further features in the described preferred embodiments the method further comprises etching at least one facet so as to form a microlens array on the facet.

According to still further features in the described preferred embodiments at least a few of the waveguides are tapered or partially tapered.

According to still further features in the described preferred embodiments the tapering is characterized by a smooth profile.

15 According to still further features in the described preferred embodiments the tapering is characterized by a substantially stepped profile.

According to still further features in the described preferred embodiments the plurality of layers are partially exposed at the second facet.

20 According to still further features in the described preferred embodiments at least a few of the plurality of waveguides form a planar light circuit.

According to still further features in the described preferred embodiments at least a few of the plurality of waveguides form an optical fibers array.

According to still further features in the described preferred embodiments at least a few of the plurality of waveguides are single mode waveguides.

25 According to still further features in the described preferred embodiments the waveguides are multimode waveguides.

According to still further features in the described preferred embodiments the optical resizing device or element further comprises light absorbers introduced between cores of the waveguides.

30 According to still further features in the described preferred embodiments at least a few waveguides comprise a core and a cladding the core having a higher refractive index than the cladding.

According to still further features in the described preferred embodiments at least a few waveguides comprise photonic bandgap material.

According to still further features in the described preferred embodiments the optical resizing device or element further comprises a microlens array for coupling the  
5 light into the optical resizing device or optical resizing element.

According to still further features in the described preferred embodiments the optical resizing device or element further comprises at least one fiber bundle for coupling the light into the optical resizing device or element.

According to still further features in the described preferred embodiments the  
10 optical resizing device or element are flexible.

According to still further features in the described preferred embodiments the optical resizing device or element are foldable.

According to still further features in the described preferred embodiments the optical resizing device or element serves as a component in a display system.

According to still further features in the described preferred embodiments the  
15 optical resizing device or element serves as a component in a autostereoscopic display system.

According to still a further aspect of the present invention there is provided a method of resizing a spot of light, comprising, transmitting the light through the  
20 optical resizing device of any of the preceding aspects or features.

According to still further features in the described preferred embodiments the method further comprising distorting the spot of light such as to provide a brightness gradient thereacross thereby compensating non homogenous optical losses.

According to still further features in the described preferred embodiments the  
25 method wherein the light constitutes an image.

According to still further features in the described preferred embodiments the method further comprising distorting the image such as to provide a brightness gradient thereacross thereby compensating non homogenous optical losses.

The present invention successfully addresses the shortcomings of the presently  
30 known configurations by providing an optical resizing element, optical resizing device and method enjoying properties far exceeding the prior art.

Unless otherwise defined, all technical and scientific terms used herein have the same meaning as commonly understood by one of ordinary skill in the art to which

this invention belongs. Although methods and materials similar or equivalent to those described herein can be used in the practice or testing of the present invention, suitable methods and materials are described below. In case of conflict, the patent specification, including definitions, will control. In addition, the materials, methods, and examples are illustrative only and not intended to be limiting.

#### BRIEF DESCRIPTION OF THE DRAWINGS

The invention is herein described, by way of example only, with reference to the accompanying drawings. With specific reference now to the drawings in detail, it is stressed that the particulars shown are by way of example and for purposes of illustrative discussion of the preferred embodiments of the present invention only, and are presented in the cause of providing what is believed to be the most useful and readily understood description of the principles and conceptual aspects of the invention. In this regard, no attempt is made to show structural details of the invention in more detail than is necessary for a fundamental understanding of the invention, the description taken with the drawings making apparent to those skilled in the art how the several forms of the invention may be embodied in practice.

In the drawings:

FIGs. 1a-2b are schematic illustrations of prior art techniques for manufacturing fiber based guided magnifiers.

FIGs. 3a-c are schematic illustrations of a longitudinally expanding arrangement of waveguides (Figure 3a), a partially tapered waveguide (Figure 3b) and a longitudinally expanding arrangement of partially tapered waveguides (Figures 3c), according to various exemplary embodiments of the present invention.

FIG. 3d is a schematic illustration of the embodiment of Figure 3c with more than one layer.

FIGs. 4a-i are schematic illustrations of an optical resizing element, in various exemplary embodiments of the invention.

FIG. 5 is a schematic illustration of an optical resizing device having two optical resizing elements, in various exemplary embodiments of the invention.

FIG. 6a is a schematic illustration of a small facet of a receiving optical resizing element, in various exemplary embodiments of the invention.

FIG. 6b is a three-dimensional illustration of the waveguides of the element of Figure 6a, in various exemplary embodiments of the invention.

FIG. 7a is a three-dimensional schematic illustration of the device in the embodiment in which the entry and exit facets of each optical resizing element are substantially orthogonal to each other.

FIG. 7b is a three-dimensional schematic illustration of the device on Figure 7a, in a preferred embodiment in which two pairs of optical resizing elements are employed.

FIG. 8 is a schematic illustration of the device in a preferred embodiment in which the facets of one optical resizing element are substantially parallel and the facets of the other optical resizing element are substantially orthogonal.

FIG. 9 is a schematic illustration of device in a preferred embodiment in which the facets of the optical resizing elements are substantially coplanar.

FIGs. 10a-b are schematic illustrations of a photomask layout for manufacturing an arrangement of waveguides, according to various exemplary embodiments of the present invention.

FIGs. 11a-b are schematic illustrations of process for manufacturing waveguides which are tapered both vertically and laterally.

FIGs. 12a-f are schematic illustrations of an optical resizing device in preferred embodiments in which a plurality of light sources are employed;

FIGs. 13a-c are schematic illustrations of the device in preferred embodiments in which there is more than one optical output from the device.

FIGs. 14a-b are schematic illustrations of the device in preferred embodiments in which the device comprises one or more additional optical elements.

FIG. 15 is a schematic illustration of a layer of the optical resizing element in a preferred embodiment in which the layer comprises a polarizer.

FIGs. 16a-b are schematic illustrations of the coupling between the device and a light source, in the preferred embodiment in which the light source is an image source.

FIG. 17 is a schematic illustration of a preferred embodiment in which an input image is focused on device using a lens.

FIGs. 18a-b are schematic illustrations of the coupling between the device and a light source, in the preferred embodiment one or more fiber bundles are employed.

FIG. 19 is a schematic illustration of one layer of the optical resizing element in a preferred embodiment in which the waveguides are tilted with respect to the layer's end.

5 FIGs. 20-22f are schematic illustration of an optical resizing device, in preferred embodiments in which the device is manufactured according to the principle of partially overlapping optical arrangement.

FIGs. 23a-b are schematic illustrations of a side view (Figure 23a) and a top view (Figure 23b) of a portion of a facet of device similar to the device of Figures 20-22 in a preferred embodiment in which the facet has a two-dimensional stepped shape.

10 FIGs. 23c-d are schematic illustrations of mirror shapes, according to various exemplary embodiments of the present invention.

FIGs. 24a-e are schematic illustrations of a side view of an optical resizing element with a two-dimensional stepped or slanted profile, according to various exemplary embodiments of the present invention.

15 FIG. 25 is a schematic illustration of a foldable optical resizing device, according to a preferred embodiment of the present invention.

FIGs. 26a-b is a schematic illustration of configurations in which light is coupled out from the device via an arrangement of transmitting elements, according to various exemplary embodiments of the present invention.

20 FIGs. 27a-b are schematic illustrations of process for manufacturing slanted optical resizing element, in various exemplary embodiments of the invention.

FIGs. 27c-h are schematic illustrations of an expanding structure, according to various exemplary embodiments of the present invention.

25 FIGs. 28a-c are schematic illustrations of a top view (Figures 28a-b) and a side view (Figure 28c) of layers of a device similar to the device of Figure 20-22 in a preferred embodiment in which the layers are low-weight layers.

FIGs. 29a-e are schematic illustrations of a preferred folding technique for manufacturing a device similar to the device of Figure 20-22, according to various exemplary embodiments of the present invention.

30 FIGs. 30a-b are schematic illustrations of a simultaneous process for manufacturing a plurality of optical resizing elements, in various exemplary embodiments of the invention.

FIG. 31 is a schematic illustration of a device similar to the device of Figure 20-22 in a preferred embodiment in which the device receives light from a plurality of sources.

FIGs. 32a-b are schematic illustrations of a top view (Figure 32a) and a cross sectional view (Figure 32b) of a device similar to the device of Figure 20-22 in a preferred embodiment in which the device receives optical input in the form of a plurality of monochromatic light sources.

FIGs. 33a-c are schematic illustration of techniques for coupling light out of the layers of a device similar to the device of Figure 20-22, according to various exemplary embodiments of the present invention.

FIGs. 34a-35c are schematic illustrations of a device similar to the device of Figure 20-22 in a preferred embodiment in which the device is used to provide an autostereoscopic image.

FIG. 36 is a schematic illustration of different optical regions in the field-of-view of a device similar to the device of Figures 34a-35c.

FIGs. 37a-b are schematic illustrations of one layer (Figure 37a) and the resulting field-of-view (Figure 37b) in the preferred embodiment in which a plurality of autostereoscopic images are provided.

FIG. 38 is a schematic illustration of the optical resizing device in a preferred embodiment in which the input image has a non uniform brightness so as to compensate differential waveguide losses.

FIG. 39a is a schematic illustration of a layer of the optical resizing element in a preferred embodiment in which the layer comprises light absorbers.

FIG. 39b is a schematic illustration of waveguides with variable cross-sections, according to a preferred embodiment of the present invention.

FIG. 40 is a schematic illustration a procedure for improving the brightness of the output light, in various exemplary embodiments of the invention.

FIG. 41 is a schematic illustration of a procedure for modifying the field-of-view of the device, in various exemplary embodiments of the invention.

30

#### DESCRIPTION OF THE PREFERRED EMBODIMENTS

The present embodiments comprise method, optical element and device which can be used for optical resizing. Specifically, but not exclusively, the present

invention can be used to provide optical resizing in various applications such as display systems and the like.

The term "optical resizing" as used herein refers to the expansion or contraction of an optical wavefront, which can be, for example, a planar light spot. In other words, optical resizing refers to the change (expansion or contraction) in the area occupied by the optical wavefront. For example, when light constitutes an image therein, the optical resizing refers to the magnification or reduction of the image, which can be effected by separation changes or size changes of picture elements (*e.g.*, pixels) of the image. The size of the area occupied by the optical wavefront is interchangeably referred to herein as the transverse area of a light beam.

The principles and operation of a device and method according to the present invention may be better understood with reference to the drawings and accompanying descriptions.

Before explaining at least one embodiment of the invention in detail, it is to be understood that the invention is not limited in its application to the details of construction and the arrangement of the components set forth in the following description or illustrated in the drawings. The invention is capable of other embodiments or of being practiced or carried out in various ways. Also, it is to be understood that the phraseology and terminology employed herein is for the purpose of description and should not be regarded as limiting.

The present embodiments exploit the technology of embedded waveguides to provide optical resizing. The embedded waveguides can be of any type known in the art, such as waveguides of Planar Light Circuits (PLC) or other arrays. Additionally, the waveguides can be single mode or multimode waveguides. The cross-section of the waveguides can be generally round, generally rectangular, or of any other geometrical figure.

Preferably, but not obligatorily, the embedded waveguides are arranged in one or more layers so as to allow their manufacturing in a layerwise fashion. However, this need not necessarily be the case, since, for some applications, the optical resizing can be achieved by an optical resizing element made of a bulk material as further detailed hereinunder.

In the embodiments in which the embedded waveguides are arranged in layers, the light can enter or exit the layers either through their surface or through their end as

further detailed hereinunder. The optical resizing of the present embodiment can be achieved by longitudinally expanding arrangements of waveguides of any type and shape. More specifically, the longitudinally expanding arrangements can comprise tapered waveguides, partially tapered waveguides, non-tapered waveguides or any combination thereof.

Referring now to the drawings, Figures 3a-c illustrate a longitudinally expanding arrangement of non-tapered waveguides (Figure 3a), a partially tapered waveguide (Figure 3b) and a longitudinally expanding arrangement of partially tapered waveguides, (Figures 3c), according to various exemplary embodiments of the present invention. Figure 3d exemplifies the embodiment of Figure 3c with more than one layer.

Before providing a further detailed description of the present embodiments, attention will be given to the advantages and potential applications offered thereby. The use of embedded waveguides allows the fabrication of planar routing and tapering elements. Additionally, when the PLC technology is employed, each or some of the waveguides can comprise several sections interconnected via mirror corners. Such design can be used to reduce or eliminate waveguide bends hence to reduce the thickness of the final product.

An additional advantage of the present embodiments is that the PLC technology allows the fabrication of waveguides with rectangular core cross section, thereby increasing the filling factor and reducing coupling losses.

The use of embedded waveguides allows the fabrication of flexible elements which can be easily assembled. For example, an optical device can be assembled with partially overlapping flexible layers, whereby instead or in addition to the bending of the individual waveguides, an entire layer can be bended. Additionally, a layerwise production process facilitates the manufacturing of foldable optical devices, whereby different layers are only partially attached thereamongst.

With reference to Figure 4a-b, according to one aspect of the present invention there is provided an optical resizing element generally referred to herein as element **10**. Element **10** comprises a substrate **12** formed of one or more layers **14**. Each layer of element **10** has an arrangement of waveguides formed and/or embedded therein. According to a preferred embodiment of the present invention the arrangement of waveguide in each layer is a longitudinally expanding arrangement. Figure 4b is a

schematic illustration of a layer **14** of element **10**. Layer **14** preferably comprises a plurality of waveguides **16** extending from a first region **18** to a second region **20** of layer **14** thereby defining a circumferential boundary **22** within layer **14**. Boundary **22** is illustrated as a dash line in Figure 4b.

5 As shown in Figure 4b, first **18** and second **20** regions are substantially parallel and located at opposite sides of layer **14**. However, this need not necessarily be the case, since, for some applications, it may not be necessary for the regions to be parallel to each other. Thus, regions **18** and **20** can have any geometrical relation therebetween. For example, as further exemplified hereinunder (see, *e.g.*, Figure 4e-f),  
10 regions **18** and **20** can be located at adjacent sides of layer **14** (*e.g.*, in substantially orthogonal relation) or at the same side of layer **14** (*e.g.*, in substantially collinear relation or substantially parallel offset relation).

As used herein, "substantially parallel" refers to a relative orientation of less than  $20^\circ$ , more preferably less than  $10^\circ$ , most preferably less than  $5^\circ$ , say about  $0^\circ$ .

15 The term "parallel", as used herein is to be understood as substantially parallel.

As used herein, "substantially orthogonal" refers to a relative orientation of from about  $70^\circ$  to about  $110^\circ$ , more preferably from about  $80^\circ$  to about  $100^\circ$ , most preferably from about  $85^\circ$  to about  $95^\circ$ , say about  $90^\circ$ .

As used herein, "substantially collinear" refers to a relative orientation of less  
20 than  $20^\circ$ , more preferably less than  $10^\circ$ , most preferably less than  $5^\circ$ , say about  $0^\circ$ . In addition, as used herein, "substantially parallel offset" refer to a case where the facets are substantially parallel but are also substantially offset by less than 50mm, more preferably less than 1mm, most preferably less than 0.1mm, say about 0.01mm.

Furthermore, although the waveguides are shown to have a substantial linear  
25 shapes, this need not necessarily be the case, since, for some applications, it may be desired to have non-linear (*i.e.*, curved) shapes. Additionally, the waveguides can be formed of non continuous sections interconnected by corner mirrors as further detailed hereinunder.

In any event, the length characterizing boundary **22** is smaller at first region **18**  
30 than at second region **20**. One of ordinary skill in the art will appreciate that such arrangement provides optical resizing in one dimension defined by regions **18** and **20** of the layer. For example, when a light beam enters layer **14** from first region **18**, propagate through waveguides **16** and exits from second region **20** its transverse area

is expanded in a direction substantially parallel to regions **18** and **20**. Conversely, when the light beam enters layer **14** from second region **20** and exits from first region **18** its transverse area is reduced in the direction parallel to regions **18** and **20**.

Figures 4c-d are schematic illustrations of facets of element **10** in a preferred embodiment in which the layers are stacked such that the smaller regions of the layers form a small facet **24** and the larger regions of the layers form a large facet **26**.

The waveguides, as stated, can be tapered such that the resizing is achieved due to both the longitudinally expanding arrangement and the tapering of the individual waveguides. Figure 4e is a schematic illustration of a preferred embodiment in which tapered waveguides are employed in a configuration in which first region **18** is substantially orthogonal to second region **20**. Still, the length characterizing boundary **22** is smaller at first region **18** than at second region **20**, so as to ensure the optical resizing. Figure 4f is a schematic illustration of a preferred embodiment in which tapered waveguides are employed in a configuration in which first region **18** is collinear with second region **20**.

Depending on the construction of regions **18** and **20** of the layers of element **10**, small facet **24** and large facet **26** can have any geometrical relations therebetween. Figures 4g-i schematically illustrate several geometrical relations between facets **24** and **26**, according to various exemplary embodiments of the present invention. Thus, when regions **18** and **20** of the layers are parallel and located at opposite sides of the layers (see, *e.g.*, Figure 4b), small facet **24** is parallel and opposite to large facet **26** (Figure 4g); when regions **18** and **20** of aligned at an angle with respect to each other (for example, substantially orthogonal, see, *e.g.*, Figure 4e), facets **24** and **26** are also aligned at the same angle (Figure 4h); and when regions **18** and **20** are located at the same side of the layer (for example, substantially collinear, see, *e.g.*, Figure 4f), facets **24** and **26** are coplanar (Figure 4i). It is to be understood, that the more detailed reference to the geometrical relations shown in Figures 4g-i is not intended to limit the scope of the present embodiments to any specific angle between facets **24** and **26**. The present embodiments thus contemplate any value for the angle between facets **24** and **26**.

Waveguides suitable for the present embodiments can have a core of high refractive index and cladding of lower refractive index, or they can comprise photonic bandgap materials. Thus, layers of waveguides suitable for the present embodiments

can be manufactured, for example, by etching grooves in layers of a low refractive index material serving as the waveguide cladding, and depositing a high refractive index material serving as the waveguide core, into the grooves. The waveguide core can be subsequently coated by an additional layer of low refractive index serving as a top cladding layer.

Photonic bandgap material waveguides can be manufactured by forming (*e.g.*, etching) optical periodic structures on a substrate of dielectric material, leaving stripes serving as the core waveguide, with no periodic structure. The optical periodic structures are characterized by spatially periodic variations in the refractive index with cycles in the sub-micrometer to micrometer range, which define a wavelength band in which no propagation of light occurs (photonic bandgap). The optical periodic structures can then be coated by a cladding layer. The advantage of using photonic bandgap materials is that there is no radiation loss in the photonic bandgap, even in waveguides sections of high curvature.

Preferably, but not exclusively, the PLC polymer lithography technology is employed (see, *e.g.*, Eldada *et al.*, "Advances in polymer integrated optics," IEEE J. Selected Topics in QE, vol. 6, 54-68, 2000). Contemplated processes for fabricating the layers of waveguides include also, without limitation, the Photobreaking process [Gallo *et al.*, "High-density interconnects for 2-dimensional VCSEL arrays suitable for mass scale production," ITCOM 2001, paper 4532-47, 2001], the casting/molding process [Kopetz *et al.*, "Polysiloxane optical waveguide layer integrated in printed circuit board," Elec. Lett. Vol. 40, 668-669, 2004], and the soft lithography process [Huang *et al.*, "Bottom-up soft lithography fabrication of three-dimensional multilayer polymer integrated optical microdevices," Appl. Phys. Lett., vol 85, 3005-3007, 2004].

The waveguides of the present embodiments can also be arrays of optical fibers embedded in the layers by means of adhesive materials, preferably without external frame, as known in the art (to this end see, *e.g.*, U.S. Patent Nos. 5,381,506, 6,597,845 6,885,800).

The optical element of the present embodiments preferably comprises many layers of waveguides. Typically, the number of layers is of the order of a several hundreds (*e.g.*, about 500 layers) to several thousands of layers (*e.g.*, about 5000 layers). The layers can be stacked together by processing a polymer wafer layer after layer or by stacking together laminated layers. The layers can also be stacked using a

combination of these techniques. Once the wafer layers are stacked, the wafer is sawed to stripes and the required facets are polished. Alternatively, the stripes can be sawed before stacking. It will be appreciated that since the optical resizing element is wide and short, many such elements can be fabricated in a parallel process.

5           The present embodiments successfully provide an optical resizing device which provides optical resizing in two-dimensions, preferably two substantially orthogonal dimensions. In various exemplary embodiments of the invention two-dimensional optical resizing is achieved by assembling several optical resizing elements which are similar in their principles and operations (but not necessarily in  
10 size) to element **10**. In other exemplary embodiments of the invention, two-dimensional optical resizing is achieved by modification of element **10**. Following is a description of preferred embodiments in which several optical resizing elements are assembled. Description of the preferred embodiments in which the two-dimensional optical resizing is achieved by modification of element **10** is provided hereinafter.

15           Reference is now made to Figure 5 which is a schematic illustration of an optical resizing device **30**, according to various exemplary embodiments of the present invention. Device **30** preferably comprises a first optical resizing element **32** which provides optical resizing in a first dimension **36**, and a second optical resizing element **34**, which provides optical resizing in a second dimension **38**. Elements **32** and **34** can  
20 each independently operate similarly to element **10** above. Alternatively, one of elements **32** and **34** can be manufactured similarly to element **10** while the other can be manufactured by conventional techniques.

To provide optical resizing in both first **36** and second **38** dimensions, element **34** is coupled to element **32** such that light exiting element **32** enters element **34**.  
25 Thus, element **34** serves as a receiving element while element **32** serves as a transmitting element within device **30**. The coupling between elements **32** and **34** can be in any way known in the art, such as via direct contact, fiber bundle, or any other optical coupling arrangement. It is advantageous to manufacture the optical resizing elements such that the smaller facet of one element matches the larger facet of the  
30 other element. Being manufactured in such manner, one of the optical resizing elements is larger than the other. Specifically, when device **30** is used for expanding light beam (*i.e.*, the light beam's transverse area is larger at the output than at the input), the first element is smaller than the second element, and when device **30** is

used for the contracting light (*i.e.*, the light beam's transverse area is smaller at the output than at the input), the first element is larger than the second element.

For example, in the embodiment illustrated in Figure 5, elements **32** and **34** are manufactured such that light enters the small facet **40** of element **32**, expanded along dimension **36**, exits element **32** through facet **42** and enters element **34** through facet **44**, which preferably has the size as facet **42** of element **32**. The light then propagates within element **34**, expanded along dimension **38** and exit through large facet **46** expanded in both dimensions.

When both element **32** and **34** are manufactured similarly to element **10**, they can be processed using the same photomask layout (such as, for example, the photomasks shown in Figures 3a, 3c, 4e and 4f) but different layer thickness. Thus, for example, element **32** can be formed of thinner layers defining the large facet illustrated in Figure 4d above (see also the three-dimensional illustration of Figure 3d) while element **34** can be formed of thicker layers defining the small facet illustrated in Figure 6a. A three-dimensional illustration of the waveguides of element **34** according to the presently preferred embodiment of the invention is shown in Figure 6b.

Reference is now made to Figure 7a which is a three-dimensional schematic illustration of device **30** in the embodiment in which the entry and exit facets of each optical resizing element are substantially orthogonal to each other. Specifically, in element **32**, small facet **40** is substantially orthogonal to large facet **42**, and in element **34**, small facet **44** is substantially orthogonal to large facet **46**. Facet **42** and facet **44** are parallel and preferably in contact to allow optical coupling between element **32** and element **34**. It will be appreciated that when this embodiment is used to transmit an image the image exiting device **30** is a mirror image of the original image. The advantages of the embodiment shown in Figure 7a are that there are less waveguide bends **48** and there is no scattered light from the propagating beam toward the large facet.

The resizing technique of the present embodiment can be repeated. Specifically, device **30** can comprise two or more pairs of optical resizing elements whereby each pair functions according to the above description; namely, one element of the pair provides the optical resizing in one dimension and the other element of the pair provides the optical resizing in other dimension. This embodiment is particularly useful when high magnification or reduction is required or in order to avoid dealing

with high aspect ratio waveguides during the fabrication process. For example a 30 times magnification can be achieved with two pairs of optical resizing elements, whereby the first pair provides 3 times magnification (in two dimensions) and the second pair provides 10 times magnification (in two dimensions).

5 A representative example of the presently preferred embodiment of the invention is illustrated in Figure 7b, for the case in which two pairs of optical resizing elements **32**, **33**, **34** and **35** are employed. As shown in Figure 7b, element **33** expands a light beam **72** in one dimension (say, along the *x* direction) to provide expanded light beam **74**; element **35** expands light beam **74** in another dimension (say, along the *y* direction) to provide an expanded light beam **76**; further, elements **32** expands light beam **76** in one dimension (say, along the *x* direction) to provide expanded light beam **78**; and elements **34** expands light beam **78** in another dimension (say, along the *y* direction) to provide expanded light beam **80**. Original light beam **72** is therefore expanded twice along the *x* direction and twice along the *y* direction.

15 The waveguides of each layer of the optical resizing element of the present embodiments can be formed using a photomask which is similar to the photomask illustrated in Figure 4e, above. The waveguide bends **48** shown in Figures 7a-b can be replaced with the corner mirrors **50** (see Figure 4e) so as to further reduce the thickness of the optical resizing elements.

20 Reference is now made to Figure 8 which is a schematic illustration of device **30** in a preferred embodiment in which the facets of one optical resizing element are parallel and the facets of the other optical resizing element are substantially orthogonal. With specific reference to exemplified embodiment, in element **32** (the transmitting element in the present example), small facet **40** is parallel to large facet **42**, and in element **34** (the receiving element in the present example), small facet **44** is substantially orthogonal to large facet **46**. Facet **42** and facet **44** are parallel and preferably in contact to allow optical coupling between element **32** and element **34**. The advantage of this embodiment is that the length of the waveguides in element **32** is shorter (about half compared to the embodiment shown in Figure 7) thus reducing the overall optical loss of the device. Still, because the input/output facets of the larger element (element **34**) are substantially orthogonal, the device enjoys the  
30 aforementioned advantageous of reduced thickness and scattered light.

Reference is now made to Figure 9 which is a schematic illustration of device **30** in a preferred embodiment in which the facets of the optical resizing elements (facets **40**, **42**, **44** and **46**) are coplanar. The waveguides of each layer of the optical resizing element can be formed using a photomask which is similar to the photomask illustrated in Figure 4f, above, whereby regions **18** and **20** are collinear. Thus, a light beam **92** enters small facet **40** of element **32**, propagates with element **32**, experience a 180° change in direction and exit facet **42** expanded along first dimension **36**. The (expanded) light beam exiting facet **42** is designated in Figure 9 by numeral **94**. Expanded light beam **94** enters small facet **44** of element **34**, propagates with element **34**, experiences an additional expansion along dimension **38** and an additional 180° change in direction, and exit facet **46** expanded along both dimensions **36** and **38**. The light beam exiting facet **46** is designated by numeral **96**. The light passing through device **30** thus experiences two expansions, one in each dimension, and two propagation flips. To this effect, the light exits device **30** propagating along its original direction and being expanded in two dimensions.

It is to be understood that the more detailed reference in the above description to specific propagation directions of the exiting light beam is not intended to limit the scope of the present invention to any entry-exit angular relations. In various exemplary embodiments of the present invention the light exits device **30** at any predetermined angle with respect to its entry angle. Thus, the angle between the entry and exit propagation directions of the light can be 0°, 90°, 180° or any other angle. The entry-exit angular relation depends on the orientation of the waveguides relative to the facets of the optical resizing elements. For example, as further detailed hereinunder, the light may enter any of the optical resizing elements of device **30** at a right angle to the surface of the input facet and be emitted at a non-right angle from the output facet. As will be appreciated by one of ordinary skill in the art, for parallel or substantially orthogonal facets, such configuration corresponds to an entry-exit angle which is other than 0°, 90° or 180°.

Broadly speaking, as device **30** includes a small element and a large element, most or all the area of device **30** has the thickness of the larger element. As will be appreciated by one of ordinary skill in the art, the thickness of each optical resizing element can be rather small due to the expanding arrangement of the waveguides. This thickness can be further reduced by down-tapering the waveguides at

predetermined sections of each layer. Representative examples of the thickness of the optical resizing element of the present embodiments include, without limitation, a thickness of from about 0.1 mm to about 100 mm, more preferably, from about 1 mm to about 10 mm.

5           Reference is now made to Figures 10a-b, which are schematic illustrations of a photomask layout for manufacturing an arrangement of waveguides, according to various exemplary embodiments of the present invention. Figures 10a-b illustrate the preferred embodiments in which regions **18** and **20** are parallel and located at opposite sides of the layer. One of ordinary skills in the art, provided with the details described  
10       herein would know how to adjust the photomask layout of the present embodiment for other cases.

          As shown in Figure 10a, the waveguides are down-tapered and squeezed before they are up-tapered and expanded towards region **20**. The down-tapering is advantageous, firstly because it can further reduced the thickness of each optical  
15       resizing element, and secondly because it allows the separation between the parallel waveguides so as to reduce or eliminate crosstalk.

          In the embodiment in which regions **18** and **20** are parallel and located at opposite sides of the layer, the thickness of device **30** is mainly dictated by the waveguide separation  $S_y$ , see Figure 10b. The thickness can be approximated by the  
20       expression  $0.5 S_y(N_1 + N_2)$  where  $N_1 \times N_2$  is the number of waveguides (for example, when device **30** is used for resizing an image,  $N_1 \times N_2$  can be the number of pixels in the image).

          In the embodiment in which regions **18** and **20** are located at adjacent sides of the layer (*e.g.*, in substantially orthogonal relation, see Figure 4e above) the thickness  
25       of the optical resizing element is dictated by the input pixels array size. If waveguide bends **48** are employed (rather than corners mirrors **50**), then the bend radius should be added to the overall thickness of the element. However, as further detailed hereinunder, parasitic losses are preferably added to the shorter waveguides by reducing the bend radius. Thus, the thickness of device **30** can be dictated by the bend  
30       radius, irrespectively of the number of pixels/waveguides.

          In order to increase waveguide separation (for eliminating crosstalk) also along the vertical direction, the waveguides can be vertically tapered at the input and output facets. With the PLC technology, vertical tapering is a well known technology (see,

*e.g.*, T. Bakke, *et al.* "Polyeric optical spot-size transformer with vertical and lateral tapers," J. Light. Tech., vol 20, 1188-1197, 2002). A process of manufacturing waveguides which are tapered both vertically and laterally is illustrated in Figures 11a-b for a single waveguide (Figure 11a) and a stack of waveguides (Figure 11b).  
5 Other methods for producing vertical tapers are discussed by Moerman *et al.*, "A review on fabrication technologies for the monolithic integration of tapers with III-V semiconductor devices", IEEE J. Sel. Topics Quantum Electron. Vol 3, 1308-1320, 1997. Thus the waveguide separation at the facet is much smaller than at the entire device, allowing improved efficiency in light coupling to the waveguides (at the facet)  
10 and reduction or elimination of crosstalk between the waveguides in the device.

According to a preferred embodiment of the present invention device **30** receives light from a plurality of sources. There are several advantages for this embodiment. First, the use of more light sources can reduce the thickness of device **30**; thickness can be reduced since the number of parallel waveguide from the input  
15 facet to the output facet is reduced. The thickness reduction factor equals the number of input light sources employed. For example, for two light sources the thickness can be halved. Another advantage is that each individual light source can have lower resolution (fewer pixels) while preserving the desired brightness. An additional advantage is that the use of plurality of sources can facilitate production of three-  
20 dimensional images, as further detailed hereinunder.

Receiving light from multiplicity of sources can be achieved in more than one way. Hence, in one embodiment, exemplified in Figure 12a, two light rays **122** and **124** enter first optical resizing element **32** from two different light sources (not shown), but any number of light sources can be employed. Although in the  
25 exemplified illustration shown in Figure 12a, element **32** is manufactured in accordance with the embodiment in which regions **18** and **20** (not shown) are collinear, but this need not necessarily be the case because, as will be appreciated by one of ordinary skill in the art, several light beam can be inputted to element **32** also in  
30 other cases. Thus, according to the presently preferred embodiment of the invention element **32** comprises two input facets, designated **40a** and **40b**, and one output facet **42**. When more than two light sources are employed, the number of input facets of element **32** are preferably adjusted accordingly (*i.e.*, three input facets for three light sources, *etc.*).

Both light beams exit element **32** through facet **42** expanded in one dimension and enter element **34** through facet **44** where they are expanded in the other dimension as further detailed hereinabove.

In another embodiment, exemplified in Figure 12b-c, device **30** comprises two optical resizing elements, designated **32a** and **32b**, both serving as transmitting elements within device **30**, and one optical resizing element, designated **34** serving as receiving element within device **30**. Four light rays, **122a,b** and **124a,b**, enter elements **32a** and **32b** and conjointly exit element **34** as further detailed hereinabove. The illustration of Figure 12b is for the embodiment in which each of optical resizing elements **32a** and **32b** is manufactured in accordance with the embodiment in which regions **18** and **20** (not shown) are collinear, and the illustration of Figure 12c is for the embodiment in which each of optical resizing elements **32a** and **32b** is manufactured in accordance with the embodiment in which regions **18** and **20** are located on adjacent sides of the layer. All combinations between the above embodiments are also contemplated.

In an additional embodiment, exemplified in Figure 12d-f, device **30** receives optical input in the form of a plurality of monochromatic light sources and uses the optical input to produce a resized chromatic light beam. For example, a plurality of monochromatic images can be magnified and combined by device **30** to provide a magnified chromatic image.

In the representative example shown in Figure 12d, three monochromatic images (*e.g.*, a red image a green image and a blue image) are transmitted from three monochromatic image sources (not shown) to enter three optical resizing elements **32a**, **32b** and **32c**, respectively. Each of elements **32a**, **32b** and **32c** magnifies the respective monochromatic image in one dimension and transmits it to element **34**. Element **34** magnifies the monochromatic images and combines them in the other dimension to provide a magnified chromatic image.

To combine the monochromatic images to a chromatic image, element **34** is preferably manufactured from an alternating sequence of layers, whereby the waveguides of each layer are preferably optimized according to the average wavelength of one monochromatic image. Shown in Figure 12d are three types of layers, designated by numerals **37a**, **37b** and **37c**. Layers **37a**, **37b** and **37c** can be optimized, for example, to typical average wavelengths of red, green and blue

monochromatic images, respectively. The length of the waveguides is selected according to the position of elements **32a**, **32b** and **32c** relative to element **34**. Figure 12e is a schematic illustration of layers **37a**, **37b** and **37c** in the alternating sequence, for the case of red, green and blue images. This embodiment is advantageous because the use of wavelength specific waveguides reduces or eliminates possible dispersion. An additional advantage of this embodiment is that the image source can have less optical elements such as lenses and multiplexers. Thus, instead of being built at the input source with multiplexers and lenses, the image source is multiplexed at element **34**.

Elements **32a**, **32b** and **32c**, which, as stated receive and transmit monochromatic images, can all be manufactured using similar or identical photomasks, see, *e.g.*, the photomask illustrated in Figure 12f.

It is to be understood that the present embodiments are suitable for imagery optical data as well as non imagery optical data and the more detailed reference to imagery data is not to be interpreted as limiting the scope of the invention in any way. Thus, for example, the present embodiments can be used to provide a chromatic image or a chromatic back illumination for another display device, *e.g.*, LCD panel with a stripe matrix of red-green-blue (RGB) light from three filtered light source, LEDs or laser sources.

Reference is now made to Figure 13a-c which are schematic illustrations of device **30** in preferred embodiments in which there is more than one optical output from the device.

In one embodiment, schematically illustrated in Figure 13a, optical resizing element **32** transmits light to more than one direction. Shown in Figure 13a are three optical resizing element, **32** **34a** and **34b** whereby element **32** transmits light to both elements **34a** and **34b**. Thus, in the presently preferred embodiment of the invention element **32** serves as a transmitting element within device **30** and elements **34a** and **34b** both serve as receiving elements within device **30**. Specifically, a light beam **132** enters element **32** and being transmitted thereby in the form of two light beams **134a** and **134b**. It is to be understood that element **32** can transmit more than two (*e.g.*, three, four) light beams.

At least one, more preferably both light beams **134a** and **134b** are independently resized (*e.g.*, expanded) in one dimension with respect to light beam

**132**. For example, when beam **132** constitutes an image, beams **134a** and **134b** can be a three time magnification image and a two time magnification image of the original image, respectively. Alternatively, if desired one beam can be a magnification image of the original image and the other can be a reduction thereof. Elements **34a** and **34b** respectively receive light beam **134a** and **134b** from element **32** and resize them in the other dimension, preferably, by the same extent as the resizing performed by element **32** so as to preserve the aspect ratio. Device **30** thus provides two output light beams **136a** (produced by element **34a**) and **136b** (produced by element **34b**), each independently being resized in two dimensions relative to input light beam **132**.

In another embodiment, schematically illustrated in Figure 13b, optical resizing element **34** receives (expanded) light beam **134** from element **32** and transmits it to more than one direction. In the representative example of Figure 13b element **34** bifurcates the light and produces two light beam **136a** and **136b** propagating in two opposite directions.

The embodiments illustrated in Figures 13a-b can be combined, such that light beams **134a** and **134b** (see Figure 13a) are both transmitted to element **34** such that the two optical outputs (beams **136a** and **136b**) are produced by the same optical resizing element.

Additionally, element **34** can be optically fed by a plurality of optical resizing elements, each transmitting to element **34** a different light beam originated from a different light source. A representative example of this embodiment is schematically illustrated in Figure 13c, where there are two light sources (**138a** and **138b**) transmitting light beams **132a** and **132b** to two optical resizing elements **32a** and **32b** which respectively resize the beams in one dimension to produce light beams **134a** and **134b**. Element **34** receives light beams **134a** and **134b** from elements **32a** and **32b**, expands them in another dimension to produce light beams **136a** and **136b** and transmits them to two different directions (opposite directions in the present example).

With reference to Figures 14a-b, according to a preferred embodiment of the present invention device **30** comprises one or more additional optical elements **142** for performing various optical operations and/or to ease the manufacturing process. The additional optical element(s) can be formed of a plurality of waveguides in expanding or non-expanding arrangement, depending on the desired functionality thereof. In the representative example shown in Figure 14b, additional element **142** is an image

rotating element **144**. In use, light beam **146**, constituting an image therein, enters element **144** where the image is rotated by, say  $90^\circ$ , and exits element **144** as a rotated light beam **148**. Subsequently, light beam **148** enters elements **32** and **34** where it is being expanded, first in one dimension (light beam **150**) then in the other dimension (light beam **152**) as further detailed hereinabove. Image rotating element **144** is particularly useful in the embodiments in which the optical resizing elements are manufactured such that their small facet and large facet are substantially orthogonal to each other.

Figure 15 is a schematic illustration of a layer (*e.g.*, layer **14**) of the optical resizing element in a preferred embodiment in which the layer comprises a polarizer **154**. Polarizer **154** can be formed, for example, by depositing metal or alloy (*e.g.*, Cr, Au, Al, *etc.*) at gaps **156** between waveguides **16** so as to attenuate the transverse polarization mode. Preferably, the waveguides are made narrower at the region of the polarizer for efficiently stripping the transverse polarization modes. The use of optical resizing elements with polarizer **154** can allow the use of input light source which produces unpolarized light, or it may improve the state of polarization of polarized light beams.

The coupling between device **30** and the light source can be by direct contact, or, alternatively, via one or more additional optical elements, such as, but not limited to, an arrangement of microlenses or diffractive optical elements.

Reference is now made to Figures 16a-b which are schematic illustrations of the coupling between device **30** and a light source, in the preferred embodiment in which the light source is an image source. Shown in Figure 16a are several waveguides **16** of device **30**, an image source **160** and a coupler **162** for providing optical coupling between device **30** and image source **160**. In the present example, image source **160** is an LCD micro-display. Coupler **162** preferably comprises a microlens array **164** and a polarizer **166**. The use of microlens array **164** is advantageous because, typically, an LCD panel includes, on the output side, a polarizer and an LCD protective glass, and the microlens array provides better coupling efficiency. The microlens array can be manufactured using any way known in the art, for example, as disclosed in U.S. Patent No. 5,508,834 and U.S. Patent Application No. 20040100700.

With reference to Figure 16b, microlens array **164** can also be placed on the input optical element, such that each waveguide core is capped with one microlens, see, *e.g.*, core **161** and microlens **168** in Figure 16b. This can be done by etching the input facet of the optical resizing element with an etcher that etches the cladding **163** of waveguide **16** faster than core **161**.

Alternatively, when the LCD panel has a sufficiently thin polarizer and protective glass layers, the coupling can be carried out without the microlens array, *e.g.*, by direct contact. For example, when the overall thickness of the polarizer and protective glass is about 20  $\mu\text{m}$  or less, and the waveguides of the optical resizing element which couples to the LCD panel have a sufficiently small numerical aperture (say, about 0.25 or less). In such configuration the cross talks between neighbor pixels, which can blur the picture, can be minimized.

Figure 17 is a schematic illustration of a preferred embodiment in which an input image is focused on device **30** using a lens **176**. In this configuration a pre-magnification can be also obtained, thus relieving the required aspect ratio of the waveguides or eliminating the need for two stages magnifications as further detailed hereinunder. This configuration is particularly useful with reflecting liquid crystal micro-displays, such as, but not limited to, LCD on Silicon (LCOS) or other input panels, such as, but not limited to, Digital Light Processor (DLP). Shown in Figure 17 are a reflective liquid crystal micro-display **170**, an external light source **172** and device **30**. Light **174** from light source **172** is focused by a lens **175** on micro-display **170**, which reflects the light. The reflected light constitutes an image therein is focused by another lens **176** on device **30**.

A pre-magnification can be carried out also only in one dimension. Combining a distorted input (magnified in one dimension) with an optical resizing element can result in a compact thin device since in this case there is no need for two optical resizing elements in device **30**, and the pre-magnification element (which can be a lens) is thin.

Reference is now made to Figures 18a-b which are schematic illustrations of the coupling between device **30** and a light source, in the preferred embodiment in which the coupling is by a fiber bundle. According to the presently preferred embodiment of the invention one (Figure 18a) or more (Figure 18b) fiber bundles **180** guide the light directly to the receiving optical resizing element of device **30**. In the

embodiments in which device **30** is used to resize an image, the fiber bundle(s) are preferably composed of many fibers with small cores to enable transmission of high resolution images. Denoting the number of rows and the number of columns in the fiber bundle by  $X_1$  and  $X_2$ , respectively, the total number of fibers in the fibers is  $X_1 \times X_2$ . Representative examples for  $X_1$  and  $X_2$ , include, without limitation, from about 500 to about 2000. Preferably, but not obligatorily  $X_1 = X_2$ . The diameter of the core of the fibers is preferably less than 20  $\mu\text{m}$ , more preferably less than 15  $\mu\text{m}$ , say about 10  $\mu\text{m}$ .

When device **30** receives optical input from a plurality of light sources (see Figure 18b) each bundle transmits one optical channel. In the example shown in Figure 18b the input fiber bundle **180** is separated to four fiber bundles (**180a**, **180b**, **180c** and **180d**) which respectively feed four input facets (**182a**, **182b**, **182c** and **182d**) of device **30**.

Device **30** can also receive optical input in the form of one or more coherent light beams, *e.g.*, a laser beam. A color image can be created from a plurality (*e.g.*, three or more) of monochromatic laser devices, for example, red, green and blue laser devices which are scanned to form a picture. Such image can be projected on the input facet of device **30** which has a small cross-section. The advantages of using laser light are high brightness and the ability to calibrate the laser light spot intensity and location according to the transparency and location of the waveguides in device **30**. Preferred transparency optimization procedures in accordance with various exemplary embodiments of the present invention are provided hereinunder in the Examples section that follows.

As stated hereinabove, the light can emitted from device **30** at any predetermined angle with respect to the emitting facet. The predetermined angle can be about 90°, in which case the waveguides are formed in substantially orthogonal relation to the output facet, or any other angle in which case the waveguides are tilted with respect to the output facet.

Reference is now made to Figure 19 which is a schematic illustration of one layer of one optical resizing element of device **30** in a preferred embodiment in which waveguides **16** are tilted with respect to the layer's end. The resulting optical resizing element emits light **194** at an angle  $\theta$  (designated by numeral **190** in Figure 19) with respect to the output facet.

According to a preferred embodiment of the present invention device **30** is designed and constructed to provide three-dimensional images. The three-dimensional images can be obtained by generating two different images, of two different polarizations or two different colors. The user can then view the images using a binocular device having a different polarization or a different color for each eye, hence  
5 mimicking a three-dimensional perception of the image.

Alternatively, device **30** can function as an autostereoscopic display, whereby it is not necessary for the viewer to wear special viewing implement to keep the two images separated. The autostereoscopic is provided to the user in the form of two  
10 different images which are directed to the left and right eyes of the user. A representative example of an autostereoscopic display, according to various exemplary embodiments of the present invention is provided hereinunder (see Figures 34a-35c and the accompanying description).

Display devices are typically manufactured under a constraint of "pixel to pixel" alignment between optical coupled display panels. Specifically, for a display device to function properly, it is required to align the pixels of optical coupled panels with tolerance of microns or sub-micron. It is recognized that this requirement complicates the manufacturing process and oftentimes completely disable product manufacturability. In the present embodiments, there is no need for pixel to pixel  
15 alignment between the input picture image and element **32** or between element **32** and element **34**.

Furthermore, the numbers of pixels in the picture image can be different from the number of pixels in element **32** which in turn can be different from the number of pixels in element **34**. For doing so, without losing resolution, the number of pixels  
25 (waveguides) in the accepting element is preferably  $k$  times larger than the number of pixels (waveguide) in the transmitting element, where  $k$  is a number larger than 1, e.g., about 2 more preferably about 3. For more details, see U.S. Patent No. 6,326,939, the contents of which are hereby incorporated by reference. Thus, there is no need for a correlation between the input image pixels and the pixels of device **30**, and there is no  
30 need to align the waveguides of the two optical resizing elements.

With respect to misalignment between layer of the same optical element, misalignment of  $x$  microns between layers is translated to an effective misalignment (at the output) of  $x(M-1)$  for the case in which the small and large facet are opposite

and parallel,  $xM$  for the case in which the small and large facet are substantially orthogonal, and  $x(M+1)$  for the case in which the small and large facet are coplanar. Thus, for an output tolerance of about 0.2 mm and about ten times magnification, the layers can be stacked at the input waveguide region within about 20 microns accuracy.

5 The alignment requirements are only in one dimension. In the embodiments in which the small and large facets are parallel (opposite or coplanar), there are no alignment requirement in the transverse direction. On the other hand, in the embodiment in which the small and large facets are substantially orthogonal, the tolerance at the transverse direction, is about  $x$  microns.

10 Misalignments of  $x$  microns due to lack of planarization in the transmitting optical resizing element (*e.g.*, element **32**) are translated to a misalignment of  $xM$  microns (where  $M$  is the magnification of the receiving element) at the output. Rotation misalignment between the two optical resizing elements is preferably minimized so as to reduce image distortion.

15 Variations in the thickness and the width of the waveguides which lead to difference in the transparency of the waveguides can be added to the total loss budget of the waveguides. Preferably, some width and thickness variation can be introduced so as to suppress the Moiré fringe effects.

Reference is now made to Figure 20 which is a schematic illustration of an  
20 optical resizing device **200**, in accordance with various exemplary embodiments of the invention. Similarly to device **30** above, device **200** can provide two-dimensional optical resizing of light. Device comprises a plurality of layers **202** forming a substrate **204** having a first facet **206** and a second facet **208**. Layers **202** are arranged in a partially overlapping optical arrangement.

25 As used herein, "partially overlapping optical arrangement" of layers refers to an arrangement in which each layer includes at least one region which is optically exposed at the surface of the layer. An optically exposed region, as used herein, refers to a region capable of establishing optical communication with the environment. Thus, there is a substantially free optical path between the environment and each layer  
30 of device **200**, which optical path passes through the surfaces and the optically exposed regions of the layers. The optically exposed region can therefore emit light directed outwardly from the surface of the layer, without being substantially absorbed, reflected or scattered from adjacent layers.

The optically exposed regions can either emit light directed outwardly from or receive light directed inwardly to the surface of the layers, without being substantially absorbed, reflected or scattered from adjacent layers.

Figures 21a-b schematically illustrate a side view of two partially overlapping optical arrangements, according to various exemplary embodiments of the present invention. Shown in Figures 21a-b are layers **202** each having a surface **290** and an end **292**. Waveguides **16** are embedded in layers **202** and extending, in each layer, from a first region **293** to a second region **294** of the layer. Second regions **294** are optically exposed. Thus, irrespectively of the position of the layer within the stack, there is a substantially free optical path **296** passing through surface **290** and connecting the environment **298** with optically exposed region **294**. Thus, light **291** propagating within layers **202** (through waveguides **16**) is allowed to exit layer **202** through surface **290** and into environment **298**.

In the embodiment illustrated in Figure 21a, regions **294** are physically exposed to the environment, thus establishing optical path **296**. In the embodiment illustrated in Figure 21b there is an overlap between adjacent layers at regions **294**, such that optical path **296** passes through the layers. In this embodiment, layers **202** (or at least a portion of each layer) are manufactured from a material which enables transmission of visible light therethrough, so as to preserve optical path **296**.

The skilled artisan would appreciate that the light can be coupled out of the layers through surface **290** irrespectively whether the layers are terminated at the optically exposed regions (as exemplified in Figure 21a) or extend beyond them (Figure 21b). Preferred configurations for coupling the light out of the layers according to various exemplary embodiments of the present invention are provided hereinunder.

According to a preferred embodiment of the present invention facet **208** of device **200** is defined by the optically exposed regions of the layers. Facet **208** can be slanted or it can have a two-dimensional stepped shape (a terrace). Each layer has an expanding arrangement of waveguides defined by a circumferential boundary as further detailed hereinabove, see *e.g.*, circumferential boundary **22** in Figures 4b, 4e, 4f and 10a. Similarly to element **10** and device **30** above, a portion or all the waveguides **16** in each layer can be tapered or partially tapered, as desired. Additionally, the expanding arrangement of the waveguides **16** can be achieved by

waveguide bends and/or corner mirrors, whereby waveguide bends are favored from the standpoint of optical losses while corner mirrors are favored from the standpoint of device thickness, as further detailed hereinabove.

As will be appreciated by one ordinarily skilled in the art, the expanding  
5 arrangement of the waveguides in each layer of device **200** results in optical resizing in one dimension shown by arrow **210** in Figure 20, and the partially overlapping optical arrangement of the layers at facet **208** results in optical resizing in another dimension shown by arrow **212**.

As illustrated in the representative example of Figure 20, first facet **206** is  
10 defined by ends **216** of overlapping regions **218** of layers **202**. Figures 21c-d schematically illustrate one (Figure 21c) and several (Figure 21d) layers of device **200**, better showing end **216** of non exposed region **218**. The exposed regions of layers **202** which form facet **208** are designated in Figures 21c-d by numeral **220**.

In an alternative embodiment, illustrated in Figures 22a-c, layers **202** are  
15 partially exposed at both first **206** and second **208** facets. Specifically, facet **206** (Figures 22a-b) is defined by exposed regions **222** (Figure 22c) and facet **208** is defined by exposed regions **220**. The difference between the above embodiments is that when facet **206** is defined by ends of overlapping regions, the light exits device **200** at a perpendicular direction to its direction on entry, while when facet **206** is  
20 defined exposed regions, the light exits device **200** at a parallel (Figure 22b) or opposite (Figure 22a) direction to its direction on entry.

Reference is now made to Figure 22d which is a schematic illustration of  
device **200** in a preferred embodiment in which device **200** comprises two optical  
resizing elements **232** and **234**, where element **232** provides optical resizing in one  
25 dimension (designated by arrow **212**) and element **234** receives the partially resized light and resizes it the other dimension (arrow **210**). Preferably, but not obligatorily, element **232** is smaller in size than element **234**.

Elements **232** and **234** can be manufactured in separate manufacturing  
processes and be optically coupled thereafter, or more preferably, they can be  
30 integrated element in which case their optical coupling can be achieved during the manufacturing process. In the latter embodiment, each layer of device **200** has two portions **432** and **434** (not shown, see Figure 22e-f), portion **432** is designated for element **232** and portion **434** is designated to element **234**. This embodiment is better

illustrated in Figures 22e-f showing top view of one layer (Figure 22e) and several layers (Figure 22f) stacked one over the other in a partial overlapping optical arrangement. In the layer shown in Figure 22e, the waveguides extend from a first region **18** to a second region **20**, thereby forming a longitudinally expanding arrangement, as further detailed hereinabove. Also shown in Figure 22e are first **432** and second **434** portion which, as stated are designated for elements **232** and **234**, respectively. Once the layers are stacked, element **232** is formed from portions **432** and element **234** is formed from portions **434**.

In the embodiment in which manufactured in separate manufacturing processes, each of elements **232** and **234** can be independently manufactured layerwise or as a bulk, as further detailed hereinunder (see Figures 26-27h and accompanying description. According to a preferred embodiment of the present invention element **232** serves as the transmitting element within device **200** whereby light entering element **232** through facet **236** is transmitted by element **232** through facet **238** which is located at the interface between elements **232** and **234**. In this embodiment, element **234** serves as the receiving element within device **200** whereby the light transmitted by element **232** is received by element **234** through facet **240**, also located at the interface between the devices. After being resized in dimension **210** the light exits element **234** through facet **242**.

In the exemplified configuration shown in Figure 22d optical resizing element **234** is manufactured according to the principle of partially overlapping optical arrangement, as further detailed hereinabove, whereby the exposed portions of its layers form facet **242**. Similarly to facet **208** above, facet **242** can be slanted or it can have a terrace shape. Also illustrated in Figure 22d is an expanding structure **224** which according to a preferred embodiment of the present invention is optically coupled to facet **242**. Expanding structure **224** serves for expanding light rays passing therethrough, as further detailed hereinunder.

As will be appreciated by one of ordinary skill in the art, the expanding arrangement of the waveguides in element **232** results in optical resizing in dimension **212**, and the terrace or slanted shape of facet **242** of element **234** results in optical resizing in dimension **210**.

The cladding layers of device **200** can be made of an absorbing or non-absorbing material, as desired. The advantage of using absorbing material is that it

improves the contrast, and the advantage of using a transparent material is that it allows the manufacturing of a transparent display which does not block the scene behind it. Additionally, polarizers can be added between the waveguides cores, as further detailed hereinabove (see Figure 15).

5           The coupling of light out of the partially overlapping optical arrangement of the present invention can be achieved in more than one way. In one preferred embodiment, the light is coupled out of facet **208** using an arrangement of reflecting elements. In this embodiment, the light propagates through the waveguides substantially in parallel to the surface of the layer until it impinges on the reflecting  
10 elements which redirect the light outwards through the surface. In another embodiment, the light is coupled out of facet **208** using an arrangement of transmitting elements (typically waveguides). Also contemplated is a combination of reflecting and transmitting elements. The embodiment in which the light is coupled out via an arrangement of reflecting elements is described hereinbelow, and the embodiments in  
15 which the light is coupled out via an arrangement of transmitting elements or a combination of reflecting and transmitting elements are described hereinafter (see Figures 26-27h).

Reference is now made to Figures 23a-b, which are schematic illustrations of a side view (Figure 23a) and a top view (Figure 23b) of a portion of facet **208** of device  
20 **200** in a preferred embodiment in which facet **208** has a two-dimensional stepped shape (a terrace). Reference is also made to Figures 23c-d which are schematic illustrations of a mirror **282** placed in the layers of device **200**, according to the presently preferred embodiment of the invention.

As shown in Figures 23a-b, a few mirrors **282** (*e.g.*, total internal reflection  
25 mirrors) with different reflection coefficients are preferably placed in a reflection region **283** of each layer **202** of device **200**. Mirrors **282** collect light propagating in the layers and redirect it so as to couple the light out of facet **208**. The propagating light and redirected light are designated in Figures 23a-b by numerals **284** and **286**, respectively. Mirrors **282** are preferably wide, so as to optimize the collection and  
30 coupling of the light. The different reflection coefficients of mirrors **282** can be realized by providing mirrors of different heights.

Alternatively, mirrors **282** can be narrow, without variations of reflection coefficients such that light striking the mirrors is fully reflected. Preferably, mirrors

**282** are disposed substantially homogeneously across reflection region **283** to facilitate efficient collection of light **284**. Such configuration results in a substantially homogeneous reflection of light out of facet **208**. As shown in the top view of facet **208** (Figure 23b) redirected light **286** can be further expanded in two dimension upon striking the boundary between facet **284** and the external medium. Such expansion typically occurs when facet **284** is coated by a protective coat, such as, but not limited to, a glass or a polymer or when the light is coupled downside as illustrated in Fig. 33b. The redirected light before and after being expanded on the protective coat, is illustrated in Figure 23b by squares **286** and circles **288**, respectively.

Still alternatively, both methods can be combined, for example, by placing narrow partially reflecting mirrors across the terrace surface. The mirrors can be fabricated in polymer waveguides, *e.g.*, by molding or ablation process.

With reference to Figures 23c-d, mirrors **282** can have a planar (Figure 23c) or non-planar (Figure 23d) shape. Flat mirrors are preferred in applications in which a narrow or moderate field-of-view is required and can be obtained, for example, using a series of laser ablation pulses. Non-planar mirrors are preferred in applications in which the required field-of-view is wide, and can be obtained, for example, using fewer (*e.g.*, one) laser ablation pulse.

Reference is now made to Figures 24a-e which are schematic illustrations of a side view of optical resizing element **234**, according to various exemplary embodiments of the present invention. Layers **202** of element **234** serve for two purposes: (i) coupling the light out of element **234**, and (ii) facilitating the optical resizing (expansion, in the present example) in dimension **210**. The propagating light and the outgoing light are designated in Figures 24a-e by numerals **246** and **247**, respectively. Also shown in Figures 24a-e is the typical pixel size characterizing outgoing light **247**. The pixel size designated in Figures 24a-e by numeral **249**.

The coupling of light out of element **234** can be achieved in more than one way. In one embodiment, illustrated in Figures 24a-b, layers **202** comprises mirrors **248** positioned on the terminals the waveguide so as to redirect light rays **246** propagating therethrough. Mirrors **248** can be 45° mirrors - total internal reflection (TIR) mirrors, full or partially reflective mirrors and they can have a planar or non-planar shape, as further detailed hereinabove. Additionally, the mirrors can be coated with a high reflecting material. Figure 24a illustrates the preferred embodiment in

which 45° mirrors are used and Figure 24b illustrates the preferred embodiment in which TIR mirrors are used.

In another embodiment, illustrated in Figure 24c, grooves **250** are formed in layers **202** so as to force total internal reflection hence redirection of light out of the layers. In an alternative embodiment, illustrated in Figure 24d, element **234** comprises a Bragg reflector **261** which redirects the light rays out of light out of element **234**. In still another embodiment, element **234** comprises a holographic optical element **263**, designed and constructed the redirect the light rays out of light out of element **234**.

Element **234** can be manufactured as a part of element **232**, in which case the layers forming the elements are made of a single substrate, using, for example, a photomask of the type shown in Figure 21c above. More preferably, each layer can be processed using a different mask so as to reduce potential vertical coupling. Such manufacturing process also reduces the length of the waveguides, whereby a single diagonal path can be utilized (rather than two perpendicular paths). The layers can be fabricated to their exact length and then stacked to form facet **242**, or they can be first stacked to form the facet **242** and then polished or cut thereafter to form facet **236**.

Element **234** can also be manufactured as a separate unit, for example by stacking layers with substantially parallel waveguides one over the other, to form a partially overlapping optical arrangement in which facet **242** has a slanted or terrace shape.

According to a preferred embodiment of the present invention, the layers of device **200** are made of polymeric material, more preferably a flexible polymeric material, to facilitate flexibility of device **200**. Furthermore, the layers of device **200** can be attached to each other on one side (*e.g.*, the input side) while allowing their other sides (*e.g.*, the output side) to be detached. With such configuration, device **200** can be made foldable. A representative example of a foldable device is illustrated in Figure 25, showing device **200** in which layers **202** are attached on their input side **251** and allowed to be detached on their output side **255**. In the preferred embodiment in which device **200** is manufactured as two separate elements **232** and **234** which are coupled thereafter, it can be made foldable by fully attaching the layers of element **232** and partially attaching the layers of element **234**.

Reference is now made to Figures 26a-b which are simplified illustrations of a side view (Figure 26a) and an exploding diagram (Figure 26b) of the preferred

embodiment in which the light is coupled out via an arrangement of transmitting elements. With reference to Figure 26a, an optical resizing element **110** has a first **112** and a second facet **114**, where facet **114** is slanted at an angle  $\beta$  hence being larger than facet **112**. Element **110** has a plurality of waveguides **16** extending from facet **112** and bended towards facet **114**, thus providing optical resizing along direction **115**.

In the exemplified configuration shown in Figure 26a, waveguides **16** arrive at facet **114** at an angle  $\psi$ , conveniently defined relative to the normal **116** to the facet.  $\psi$  can have any value which allows the optical communication between element **110** and the environment and provide optical resizing. Generally, optical communication and optical resizing can be achieved whenever with the environment for any value of  $\psi$  which is lower than some angle  $\psi_c$ . Preferable,  $\psi$  is approximately zero, in which case waveguides **16** arrive to facet **114** approximately perpendicularly.

Bended waveguides can be manufactured, *e.g.*, according to the principles of element **10** above. For example, referring to the exploding diagram of Figure 26b, layers of trapezoidal or similar shape can be stacked one onto the other, such that their surfaces **117** substantially overlap, and their ends **119** form slanted facet **114**. Light thus propagates within the layers (through the waveguides) and exits the layer through end **119**.

Element **110** can be optically coupled to any of the above optical resizing elements such as to provide optical resizing in two dimensions. For example, element **110** can replace element **34** of device **30** or element **234** of device **200**.

Figures 27a-b, schematically illustrates another preferred manufacturing process of element **234**. In this embodiment, element **234** is processed by stacking alternating sheets of high index material and low index material to form a stack **231** before the formation of waveguides **233** therein. Subsequently, a slant cut is performed in stack **231** to form slanted facet **242**. Once facet **242** is prepared individual waveguides **233** are formed in stack **231** by etching grooves **235** therethrough. To avoid too deep etching, the process can be executed in batches of, say, tens or hundreds of layers, whereby the grooves are etched batch by batch. Thus the manufacturing process preferably includes four steps, in which in a first step batches of stacked layers are prepared, in a second step the batches are etched to form the grooves therein, in a third step the batches are stacked one onto the other, and in the fourth step the stack of batches is cut along a slanted line to form slanted facet **242**.

Grooves **235**, which separate between the waveguides of each layer, may be filled with a filling material whose refractive index is lower than the refractive index of the waveguides (the high index material). If desired, the difference between the refraction indices of the filling material and the waveguides is preferably large (*e.g.*, about 0.1 or more), so as to provide a wide field-of-view at the output of element **234**. The filling material preferably has enhanced light absorbing properties to reduce scattered light. Representative example of such material include, without limitation, is a black tone added to the low index polymer. Alternatively, grooves **235** can remain unprocessed in which case the waveguides are separated by air.

10 An additional manufacturing process for device **200** is provided hereinafter (see Figures 29a-e, below).

Reference is made to Figures 27c-h which are schematic illustrations of expanding structure **224**, according to various exemplary embodiments of the present invention.

15 As stated, structure **224** serves for expanding the light beam passing therethrough, in addition to the optical resizing provided by element **232** or as an alternative thereto. Thus, in the preferred embodiments in which structure **224** is employed, device **200** may or may not include optical resizing element **232**.

Referring to Figures 27c-e, in the preferred embodiment illustrated in Figure 20 27c, structure **224** comprises a stack of patterned layers; in the preferred embodiment illustrated in Figure 27d structure **224** comprises a bulk of guiding material patterned and grooved; and in the preferred embodiment illustrated in Figures 27e-f, structure **224** comprises a stack of layers of banded waveguide in expanding arrangement, similarly to the construction and operation of optical resizing element **10**. To reduce reflection at the interface between element **234** and structure **224**, an antireflection coat or an index matching material **254** can be added between facets **242** and structure **224**.

25 In the latter embodiment (Figures 27e-f), the shape and materials of element **234** and structure **224** are preferably selected such that guided light is bent towards the inner side **275** of facet **242** while scattered, non-guided light, continues to propagate in its original direction impinging on inner side **275** of facet **242** at an angle which is above the critical angle for total internal reflection. As will be appreciated by one

30

ordinarily skilled in the art, when non-guided light is not emitted from facet **242**, device **200** is less sensitive to contrast reduction due non-guided light.

Thus, according to the presently preferred embodiment of the invention the scattered light is not emitted from facet **242**. In another embodiment the waveguides of structure **224** have higher index of refraction compared to the waveguides of element **234**. In this way the aspect ratio (cladding layer width to thickness) at element **224** can be eased. Element **234**, shown in Fig 27f, is composed of layers of core material and layers of cladding material. Being deposited and not etched, cladding layers which can be substantially thinner than the core layers, can be fabricated. In the embodiment shown in Fig. 27e, structure **224** is composed of thick layers with wide core and relatively wide cladding barrier. As too narrow cladding barriers are difficult to be fabricated in a thick layer, it is preferred to increase the width of the waveguides (and barriers).

According to a preferred embodiment of the present invention the spatial and optical parameters of element **234** and structure **224** are selected so as to satisfy Snell's law. Specifically,  $N_1 \sin \theta_1 = N_2 \sin \theta_2$  and  $W_1/W_2 = \sin \phi_1/\sin \phi_2$ , where  $N_1$ ,  $N_2$  are the refraction indices of the waveguides of element **234** and structure **224**, respectively,  $W_1$ ,  $W_2$  are the thickness of the layers of element **234** and the width of layers of structure **224**, respectively,  $\phi_1$  is the slanting angle  $\phi_1$  of facet **242**,  $\phi_2$  is the banding angle of the waveguides of structure **224**,  $\theta_1 = 90^\circ - \phi_1$  and  $\theta_2 = 90^\circ - \phi_2$ . As a numerical example, for  $N_1 = 1.50$ ,  $\phi_1 = 5.7^\circ$ ,  $N_2 = 1.7$  a ratio between  $W_2$  and  $W_1$  is  $W_2/W_1 = 4.8$ .

When the waveguides of element **234** are separated by grooves (rather than formed in the individual layers, see Figures 27a-b and the accompanying description), structure **224** is preferably manufactured using the same technology. The advantage of this embodiment is that it can reduce optical losses at the interface between element **234** and structure **224**. Additionally, the use of the etching technology preserves a high index contrast. Thus, according to a preferred embodiment of the present invention structure **224** is fabricated and attached to stack **231** (see Figure 27a-b) before etching. Thereafter, stack **231** and structure **224** are etched to form the grooves. Within structure **224**, low spatial modes (perpendicular to the grooves) are guided between the cladding layers thereof and the high spatial modes are guided between the grooves.

In the embodiment illustrated in Figures 27g-h, structure **224** comprises a stack **256** of layers **258** with regions **252** of high refractive index and regions **253** of low refractive index. The regions can be cuboids or have any other geometrical shape. Light propagates through regions **252**, substantially perpendicular to layers **258**. The lower layer of structure **224** (designated layer **258a**) is an array of high index cuboids terminated by mirrors **260** (e.g., TIR mirrors) which are preferably, but not obligatorily curved for enhancing the beam divergence with structure **224**. Regions **252** of the other layers **258** of structure **224** are preferably larger than regions **252** of layer **258a** for reducing alignment tolerance requirements. When the mirrors are formed of or coated with metal, the space between element **234** and structure **224** is preferably filled with low refractive index filling material for reducing back reflections and beam divergence. Within the layer of structure **224**, the space between the regions **252** can be filled with absorbing black material to reduce scattered light and improve display contrast. Optical coupling between element **234** and structure **224** can also be effected by providing waveguides with slanted ends within element **234** (see Figure 27h).

Reference is now made to Figures 28a-c which are schematic illustrations of a top view (Figures 28a-b) and a side view (Figure 28c) of layers of device **200** in a preferred embodiment in which the layers are low-weight layers. Figure 28a is a top view of layer **202** of one optical resizing element (element **232**, element **234** or both elements **232** and **234** in the embodiment in which they have common layers). As shown in Figure 28a, waveguides **16** are only partially tapered at their end **262**, while along most of their length the cross section remains substantially unchanged. According to the presently preferred embodiment of the invention waveguides **16** are coated with a thin layer **264** of lower index cladding material (not shown, see Figure 28c) and the reminding space can be left substantially empty. Such configuration allows the reduction of weight of each layer hence also of device **200**. For construction purposes, supporting members **260** are preferably placed between waveguides **16**, so as to maintain the planar shape of each layer and prevent collapsing of layers. Supporting members **260** can be made of short section waveguides which are fabricated in parallel with the entire waveguides. Members **260** can have any geometrical shape (e.g., a cuboid).

Figure 28b is a top view of layer **258** of expanding structure **224**. In a similar way to layer **202**, the high refractive index regions **252** of structure **224** can be spaced apart so as to reduce the weight of each layer of structure **224**. Supporting members **260** can be placed between regions **252** to maintain the planar shape of each layer of structure **224** and prevent collapsing,

Figure 28c is a side view of layers **202** or **258**, showing members **260** positioned between adjacent light transmitting elements (waveguides **16** or high refractive index regions **252**). Also shown in Figure 28c is the preferred construction of each individual layers in which the light transmitting elements are formed on a bottom cladding layer **266** and coated by a top cladding layer **264**.

Another way to reduce the overall weight of device **200** is to minimize the empty areas on each layer by manufacturing layers in the shape of the circumferential boundary **22**, as shown in Figure 21c above.

Reference is now made to Figures 29a-e which are schematic illustrations of a preferred folding technique for manufacturing device **200**, according to various exemplary embodiments of the present invention. The folding technique is advantageous in applications in which it is preferred to manufacture rectangular layers, e.g., to facilitate mass production of the layers. The folding technique can be employed both for manufacturing any part of device **200**. Specifically, the folding technique can be employed for manufacturing elements which provide optical resizing in one dimension or two dimensions. In the representative examples illustrated in Figures 29a-e, the folding technique is employed for manufacturing optical element which provides optical resizing in two-dimensions, whereby the expanding arrangement of waveguides in each layer provides the optical resizing in the first dimension and the partially overlapping optical arrangement provides the optical resizing in the second dimension.

As stated hereinabove, the layers of device **200** are preferably formed of a flexible polymer. Additionally, the layers are preferably made sufficiently thin to allow their folding. Once a rectangular layer is formed it is being folded to form a predetermined angle of about  $90^\circ$  (with a radius of curvature allowed by the polymer waveguides so as not to increase the bend loss). The folded layer thus comprises an expanding arrangement of waveguides, whereby the input region is smaller than the output region. A representative example of a folded layer **270** with an input region

273 and an output region 271 is illustrated in Figure 29a, and selected steps of the manufacturing process are illustrated in Figures 29a-d.

Shown in Figure 29a-d are a folded layer 270 (Figure 29a) having input waveguides 280 and output waveguides 276, and an additional layer 272 (Figure 29b) which is added to folded layer 270, in a manner such that the output waveguides 274 of layer 272 are aligned to the output waveguides 276 of layer 270 (Figure 29c). Layer 272 is then folded (Figure 29d) such that the input waveguides 278 of layer 272 are aligned with the input waveguides 280 of layer 270. A top view of the resulting partially overlapping arrangement of layers is schematically illustrated in Figure 29e, showing exposed regions 220 and overlapping regions 218.

It is understood that the above fabrication process can also be carried out in a reverse order. In this embodiment, the input waveguides 280 of layer 270 are aligned first and the output waveguides 274 of layer 272 are aligned thereafter.

Figures 30a-b are schematic illustrations of a simultaneous process for manufacturing four optical resizing elements, in various exemplary embodiments of the invention. Figure 30a illustrates a top view of layers 300 which can be used to form four optical elements. Once layers 300 are prepared, they are stacked and cut along vertical path 306 to form two stacks 302 of layers (see Figure 30b). Subsequently stack 302 can be cut along a slanted path 304.

Reference is now made to Figure 31 which is a schematic illustration of device 200 in a preferred embodiment in which device 200 receives light from a plurality of sources. In the representative example illustrated in Figure 31, device 200 receives optical input from four light sources (not shown). Device 200 comprises two optical resizing elements, designated 132a and 132b, both serving as transmitting elements within device 200, and one optical resizing element, designated 134 serving as receiving element within device 200. Element 134 comprises a slanted or terrace facet 242 and is optically coupled to both elements 132a and 132b. The principles and operations of elements 132a and 132b are similar to the principles and operations of elements 32a and 32b above, *mutatis mutandis* the coupling to slanted element 134. Two light beams enter each one of elements 132a and 132b (beams 310a and 311a enter element 132a, beams 310b and 311b enter element 132b). The light beams are transmitted from elements 132a and 132b to element 134 and conjointly exit element 134, as expanded light beam 314.

Reference is now made to Figures 32a-b which are schematic illustration of a top view (Figure 32a) and a cross sectional view (Figure 32b) of device **200** in a preferred embodiment in which device **200** receives optical input in the form of a plurality (*e.g.*, two or more) of monochromatic light sources and uses the optical input to produce a resized chromatic light beam. Figure 32b is a cross sectional view along the cut **AA'** in Figure 32a. Device **200** can be used, for example, to provide a magnified chromatic image using a plurality of monochromatic images, as further detailed hereinabove.

In the representative example shown in Figures 32a-b, device **200** comprises a plurality of layers **320** in a partially overlapping optical arrangement forming three input facets **326a**, **326b** and **326c**, and one output facet **328** having a slanted or terrace shape, as further detailed hereinabove. Layers **320** can be manufactured using the folding technique or using any other of the aforementioned technique. It is to be understood that although Figures 32a-b describes the embodiment in which a single element (the waveguides stack) provides two-dimensional optical resizing, it is not intended to exclude the embodiment in which two optical elements are used, (*e.g.*, elements **132** and **134**, above).

Referring now to Figure 32a-b, three monochromatic optical inputs **322** (*e.g.*, an RGB input) are transmitted from three monochromatic image sources (not shown) to device **200**. Layers **320** of device **200** are preferably arranged in an alternating sequence, whereby the waveguides of each layer are optimized according to the average wavelength of one monochromatic input. Thus, for example, a first type of layers **320a** is optimized for red light, a second type of layers **320b** is optimized for green light, and a third type of layers **320c** is optimized for blue light. The layers are coupled to the different monochromatic light sources in accordance with their wavelength optimization. Each layer couples the light out of device **200** using mirrors **324** (*e.g.*, TIR mirrors) or using any other way as further detailed hereinabove. Mirrors can also be optimized to the average wavelength of the corresponding optical input.

As stated, the present embodiments are suitable for imagery optical data as well as non imagery optical data. Specifically, the present embodiments can be used to provide a chromatic image or a chromatic back illumination for another display device, as further detailed hereinabove.

The layers of device **200** are better shown in Figures 33a-c which schematically illustrate the coupling of light out of the layers. Shown in Figures 33a-c are layers **331**, arranged in a partially overlapping optical arrangement. Each layer end with a mirror **333**, preferably a TIR mirror, such that light **335** propagating within layers **331** is being redirected by mirrors **333** and coupled out of the layers.

Depending on the orientation of mirrors **333**, light **335** can exit through the free side **337** of the layer's reflection region **345** (see Figure 33a) or through a side **339** of reflection region **345** which is engaged by adjacent layers (see Figure 33b-c). The embodiment illustrated in Figure 33a is referred to herein as a forward light coupling and embodiment illustrated in Figure 33b is referred to herein as a backward light coupling. Backward light coupling is preferred in configurations in which the layers have substantial uniform thickness and the overall thickness of the layers at the emitting region of device **200** is small (typically, without limitation, lower than 10 mm, *e.g.*, about 2 mm). The advantage of the backward light coupling is in its simpler fabrication process and in its simple depositing of (high reflection) coating on the mirrors. The mirrors can be produced during or after the production of the waveguides, or they can be produced in a single step once several or all the layers are laminated.

According to a preferred embodiment of the present invention device **200** comprises a light transmissive plate **341** disposed in a slanted orientation over layers **331**. Additionally, the gap between layers **331** and plate **341** can be filled with an index matching material **343** such that light **335** is coupled out of device **200** substantially perpendicularly to plate **341**. Plate **341** is particularly useful in the backward light coupling embodiment in which roughness of the back surface can deteriorate the light out-coupling.

Devices **200** and **30** can also be used to provide three-dimensional images, by generating two different images, of two different polarizations or two different colors, as further detailed hereinabove. For two different polarizations device **200** can be constructed similarly to Figure 32, with two optical inputs at two different polarizations (instead of different colors). The user can then view the images using a binocular device having a different polarization for each eye.

In another embodiment, devices **200** and **30** can function as an autostereoscopic display. This can be done in more than one way, as further detailed hereinbelow with reference to Figures 34a-d and 35a-c.

Hence, in various exemplary embodiments of the invention device **200** is manufactured with two input facets, **330** and **332** each receives a different image, designed to be viewed by the left eye and the right eye of the user. An output facet **338** directs the optical information arriving to input **330** into the left eye and the optical information arriving to input **332** into the right eye.

Referring to Figures 34a-d, the layers of device **200** can be arranged such that the optical information arriving to input **330** is directed to the left eye and the optical information arriving to input **332** is directed to the right eye. This can be done by an appropriate orientation of the mirrors **334** of the different layers to focus the output beam to a single spot **336**, also known as the "sweet spot" of the autostereoscopic image (see Figure 34c). The user can then view a three-dimensional image by placing the left eye in the left part **344** of the sweet spot and the right eye in the right part **342** of the sweet spot. When device **200** is flexible, the focusing of the output beam to spot **336** can be achieved by bending output facet **338**, as shown in Figure 34d. The advantage of the latter embodiment is that the sweet spot position can be varied by varying the curvature of facet **338**.

Referring to Figures 35a-c, the layers of device **200** can be arranged such that the waveguides **16** have an appropriate orientation to focus the output beam to spot **336**. The advantage of this embodiment is that the beam orientation is governed by the waveguide orientation and not by the mirror facet angle. Fabrication of waveguides with controlled orientation is much simpler than fabrication of mirrors with controlled facet angle. In another preferred embodiment the waveguides orientation is the same but the mirror orientation is altered in order to reflect the beams to the desired direction.

Figure 36 schematically illustrates different optical regions in the field-of-view of device **200**, in the preferred embodiment in which devices **200** provides two optical outputs, a "left" output **346** and a "right" output **348**. As shown in Figure 36, the field-of-view generally includes four optical regions. A mixed view region **350** in which both outputs are combined to a two-dimensional image, a sweet spot region **336** in which both outputs are combined to a three-dimensional image, and two single side

regions **352** and **354** which are shadowed from one output hence contains only two-dimensional information of the other output: **348** or **346**, respectively. Regions **352** and **354** can be resized (reduced or enlarged) as desired by controlling the width of the output field.

5 Reference is now made to Figures 37a-b which are schematic illustrations of one layer (Figure 37a) and the resulting field-of-view (Figure 37b) in the preferred embodiment in which device **200** provides a plurality of autostereoscopic images. As shown, the end portion **360** of each waveguide **16** designated to emit light through the output facet splits into a plurality of waveguides (three waveguides **362a**, **362b** and  
10 **362c** in the present example), each being terminated by a separate mirror (in the present example mirrors **364a**, **364b** and **364c**). The waveguides are oriented to focus the respective portion of light onto different sweet spots (spots **366a**, **366b** and **366c** in the present example). As will be appreciated by one of ordinary skill in the art, the present embodiment can also be employed to provide a plurality of two-dimensional  
15 images, to a plurality of directions. For example, when device **200** is implemented in a display device, users observing the display from different directions can view different images.

Similarly to device **30** above, there are several ways to couple device **200** to a light source. The coupling can be done utilizing a coupler, *e.g.*, a microlens array with  
20 or without a polarizer, as further detailed hereinabove (see Figure 16a). Alternatively, device **200** can function without a coupler or using a microlens array which is placed or formed on the input optical element, as further detailed hereinabove (see Figure 16b). In another embodiment, an input image can be focused on device **200** using a lens or another focusing element as further detailed hereinabove and illustrated in  
25 Figure 17. In an additional embodiment, the coupling between device **200** and the light source is via one or more fiber bundles, as further detailed hereinabove (see Figures 18a-b). Device **200** can also receive optical input in the form of a laser beam which can be projected on the input facet of device **200**.

It is expected that during the life of this patent many relevant light transmitting  
30 devices will be developed and the scope of the term waveguide is intended to include all such new technologies *a priori*.

Additional objects, advantages and novel features of the present invention will become apparent to one ordinarily skilled in the art upon examination of the following examples, which are not intended to be limiting. Additionally, each of the various embodiments and aspects of the present invention as delineated hereinabove and as claimed in the claims section below finds experimental support in the following examples.

## EXAMPLES

Reference is now made to the following examples, which together with the above descriptions illustrate the invention in a non limiting fashion.

### EXAMPLE 1

#### *Optical Loss Optimization*

The transparency of device is affected by few loss mechanisms: (i) propagation loss within the device; (ii) bend and tapering loss within the device; (iii) coupling loss between the optical elements of the device; and (iv) reflection losses at the interfaces.

The lowest reported propagation loss for, polymer waveguides, was achieved with polymethylmethacrylate (PMMA) and deuterated polyfluoromethacrylate (d-PFMA) materials which do not contain the C-H absorption vibration bond. Values below 0.001 dB/cm for bulk at the visible region [L. Hornak, "Polymers for lightwave and integrated optics," Marcel Dekker, Inc, 1992]; 0.01 dB/cm for a multimode waveguide at a wavelength of  $\lambda=0.68 \mu\text{m}$  [Yoshimura *et al.*, "Low loss polymeric optical waveguides fabricated with Deuterated Polyfluoromethacrylate," J. Lightwave Tech, vol 16, 1030-1037, 1998] and 0.05 dB/cm for a single mode waveguide at  $\lambda=1.3 \mu\text{m}$  [Yeniary *et al.*, "Ultra-low-loss polymer waveguides," J. Lightwave Tech, vol 22, 154-158, 2004] have been reported. Thus, according to a preferred embodiment of the present invention the waveguides are polymeric waveguides, more preferably PMMA waveguides or d-PFMA waveguides.

The bend loss in various exemplary embodiments of the invention is due to interaction of light with corner mirror. A corner loss of 1.2 dB was reported for the 50x50  $\mu\text{m}$  multimode polymer waveguide with air-cladding mirror [J-S Kim and J-J Kim, "Stacked polymeric multimode waveguide arrays for two-dimensional optical interconnects," J. Lightwave Tech, vol 22, 840-844, 2004]. Lower losses, below 0.5

dB, are also achievable [Ahmad, "Ultracompact corner-mirrors and T-branches in silicon-on-insulator," IEEE Photon. Tech. Lett., vol. 14, 65-67, 2002]. When waveguides bend with radii of few mm are used instead of corner mirrors, the losses can be lower than 0.1 dB.

5           When the device is used for light expansion (*e.g.*, magnification of image) the tapering loss is negligible. For contraction uses, the typical tapering loss depends on the mode structure of the input beam and the taper length; for a fundamental input mode and a few mm long taper the loss can be below 0.1 dB. Thus, when the device is used for light expansion, the tapering can be stepped, while for contraction uses, a  
10   smooth tapering is preferred so as to minimize loss.

          The extent of coupling loss at the interface between the input light source and the device depends on the optical arrangement used to facilitate the coupling, the ratio of core to cladding in the waveguide and the ratio of width to gap of the pixels (in the extent that there is no focusing element like etched lenses at the facet). When the  
15   waveguides have rectangular cross sections, the filling factor is higher than the filling factor in case of waveguides with round cross section. The extent of coupling loss between the optical elements of the device can be negligibly low by a judicious selection of the numerical aperture of the waveguides. Specifically, according to a preferred embodiment of the present invention the numerical aperture of the receiving  
20   optical resizing element (*e.g.*, element **34**) is higher than or equals the numerical aperture of the emitting optical resizing element (*e.g.*, element **32**).

          Reflection between the input light source and device **30** can be negligibly low by placing index matching adhesive between device **30** and the optical arrangement which couples the light source to device **30**. The same applies for the reflection  
25   between the optical elements of the device. The reflection at the large facet of the second optical resizing element is given by  $(n-1)^2/(n+1)^2$  where  $n$  is the refractive index of the core. This facet can be coated with antireflection coating to further reduce the reflection.

          The device contrast ratio is only slightly affected by the propagation loss since  
30   the lost scattered light propagates substantially parallel to the large facet of device **30**. Nevertheless, light lost at the coupling between the interfaces and light scattered at the bends can reduce the contrast ratio, in particular in the embodiments in which regions **18** and **20** of the layers are parallel and located on opposite sides of the layer.

Optical losses due to waveguides non-homogenous propagation loss can be reduced or substantially eliminated (*e.g.*, reduced to less than 20 %, more preferably less than 10 %, say about 5 % or less of its former value) by illuminating the input image in a non homogenous way. For example, referring to Figure 38, the input image  
5 **380** can be distorted such that there is a brightness gradient **382** across the length and width of the image so as to compensate the differential waveguide losses.

Figure 39a is a schematic illustration of a layer (*e.g.*, layer **14**) of the optical resizing element in a preferred embodiment in which the layer comprises light absorbers **370** selected so as to improve the contrast ratio of the light propagating  
10 within waveguides **16**. Light absorbers **370** can be deposited across layer **14** or in small areas within layer **14**. The light absorbers can be black tone added to the cladding material. In the embodiments in which regions **18** and **20** are collinear or on adjacent sides of layer **14** the effect of reduced contrast ratio is less pronounced and the skilled artisan may prefer not to include light absorbers **370**. Yet, the use of light  
15 absorbers in these embodiments is also contemplated. An alternative way to improve contrast ratio is to use a slightly absorbing cladding layer between the waveguides. For example, a cladding layer with absorption coefficient of about 1 dB/cm can absorb all or most of the scattered light while adding less than 0.01 dB/cm to the waveguide loss.

20 When the propagation losses are not uniform the output light beam can have non uniform brightness. To avoid that effect, parasitic losses can be added to the shorter waveguides. This can be done, in more than one way. In one embodiment, the parasitic losses are added by reducing the waveguide width, in another embodiment the parasitic losses are added by reducing bend radius, and in an additional  
25 embodiment the parasitic losses are created by adding bends or parasitic intersected waveguides to the layers.

Alternatively, the coupling to the waveguides can be tailored by modifying the taper width (controlling the amount of light coupled to the waveguide) or the taper length (controlling the efficiency [transparency] of the taper).

30 In case where a homogenous panel is needed to be resized, the different loss of the waveguides can be compensated by assigning different cross sections to the waveguides. Figure 39b schematically illustrates an embodiment in which the longer waveguides of the layer have wider cross-sections such that more light is coupled to

the wider waveguides to overcome their higher loss (due to their longer length). In this example the waveguides are tapered towards the output panel, in order to obtain equal width there. Non tapered waveguides are also contemplated. The 90° waveguide bends can also be replaced with smooth bends.

5           The waveguides can have different length not only in the layer but also between the layers. The waveguides in the upper layer are shorter than the waveguides in the underneath layer. Equal transparency for waveguides in different layers can be achieved by assigning different waveguide width for each layer. Alternatively, the thickness of the (core) waveguides in a layer can be altered in order  
10 to compensate for the layers different waveguides' length. In this embodiment the waveguides in the upper layers are thinner than the waveguides in the lower layers.

## **EXAMPLE 2**

### ***Field-of-view Optimization***

15           According to a preferred embodiment of the present invention device **30** is designed and constructed to provide the resized light at a predetermined field-of-view. One way to achieve a predetermined field-of-view for device **30** is by a judicious selection of the waveguide parameters for the optical element from which device **30** outputs the light (e.g., element **34**). According to a preferred embodiment of the  
20 present invention the refractive indices and numerical aperture (*N.A.*) of the waveguides are selected so as to satisfy the formula:  $N.A. = \sin \alpha = \sqrt{(n_1^2 - n_2^2)}$ , where  $n_1$  and  $n_2$  are the refractive indices of the core and cladding, respectively, and  $\alpha$  is half the diffraction angle. For waveguide terminated with a linear tapering, the effective numerical aperture is  $N.A./M$  where  $M$  is the tapering magnification [Peli *et al.*, *supra*].  
25 Thus, the effective field-of-view can be selected by tailoring the tapering shape, i.e. using a non-linear taper shape. In particular, different field-of-views can be obtained for different directions.

Different field-of-views for different directions can also be achieved by selecting a first cladding material within the layers and a second, different, cladding  
30 material between layers such that the field-of-view in the longitudinal direction (parallel to the layers) differs from the field-of-view in the transverse direction (substantially orthogonal to the layers).

The field-of-view of device **30** can be enlarged by adding a diffusive screen at the output facet or by etching the output facet to make it diffusive. The diffusive screen can also be configured to compensate optical losses.

Additionally or alternatively, the field-of-view can be enlarged by increasing  
5 the difference  $\Delta n$  between the refraction indices of the core and cladding. A high  $\Delta n$  value can be chosen for the entire optical resizing element or, alternatively,  $\Delta n$  can be increased in a gradual manner towards the output facet. Gradually varying  $\Delta n$  can be achieved for example in a production process where the core is written by a direct writing UV lithography, where the core  $\Delta n$  relative to the cladding is a function of the  
10 UV exposure time. Preferably the increase in refraction index come together with a diffusion mechanism such as added scattering centers in the core material or scattering by added bends to the waveguides. These scattering mechanisms convert lower order modes to higher order modes therefore utilizing the capability of the higher  $\Delta n$  waveguide to hold higher order modes. It is the higher order modes which contribute  
15 to the large field of view patterns.

As will be appreciated by one ordinarily skilled in the art, the ability to adjust the field-of-view can significantly improve the brightness of the outputted light.

Reference is now made to Figure 40 which illustrates a procedure for improving the brightness of the output light. Broadly speaking the improvement  
20 involves an efficient collection of the light **390** from the light source **392** and an adjustment of the field of view of device **30** such that there is a minimal or no brightness loss. Specifically, according to the presently preferred embodiment of the invention the field-of-view is reduced by the same amount as the expected reduction in brightness, such all or most (say at least 90 %) of the optical energy of light **390** is  
25 carried by output light **394**. For example, suppose that a 5" screen is magnified to a 10" screen using an optical resizing device having 3dB insertion loss. In this case the expected reduction in brightness of device **30** is  $2 \times 2 \times 2 = 8$ . Suppose further that device **30** is coupled to light source **392** such that  $120^\circ$  of light **390** enters device **30**. To eliminate brightness reduction, the field-of-view of device **30** is selected to be  
30  $120/\sqrt{8} = 42^\circ$ . The present embodiment is particularly useful in situations in which it is desired to accompany the enlargement of screen size with a reduction of the field-of-view, for example, for purposes of keeping the privacy of the displayed image.

Reference is now made to Figure 41 which is a schematic illustration device **30** in a preferred embodiment in which waveguides **16** are tilted with respect to the layer's end (see, *e.g.*, Figure 19). The resulting optical resizing element emits light **394** at an angle  $\theta$  with respect to the output facet. As shown in Figure 41 the present embodiment results in a modification of the field-of-view of device **30**.

The adjustment of the field-of-view can also be employed at the interface between the optical resizing elements of device **30**, for increasing the spatial modes at the receiving element. The adjustment can be achieved by varying the relative orientation between the waveguides of different optical element and/or the value of  $\Delta n$ . For example, when the waveguides of the transmitting element (*e.g.*, element **32**) are not parallel to the waveguides of the receiving element (*e.g.*, element **34**), and  $\Delta n$  of the receiving element is higher than  $\Delta n$  of the transmitting element, the higher spatial modes exciting at the interface between the two elements successfully propagate within the receiving element. As a result, the field-of-view at the output facet of the device is increased. Increment of spatial modes can also be achieved within the optical resizing element (rather than on the interface between two such elements) by establishing slanted connection between two waveguides of the optical resizing element.

As used herein the term "about" refers to  $\pm 10\%$ .

It is appreciated that certain features of the invention, which are, for clarity, described in the context of separate embodiments, may also be provided in combination in a single embodiment. Conversely, various features of the invention, which are, for brevity, described in the context of a single embodiment, may also be provided separately or in any suitable subcombination.

Although the invention has been described in conjunction with specific embodiments thereof, it is evident that many alternatives, modifications and variations will be apparent to those skilled in the art. Accordingly, it is intended to embrace all such alternatives, modifications and variations that fall within the spirit and broad scope of the appended claims. All publications, patents and patent applications mentioned in this specification are herein incorporated in their entirety by reference into the specification, to the same extent as if each individual publication, patent or patent application was specifically and individually indicated to be incorporated herein

by reference. In addition, citation or identification of any reference in this application shall not be construed as an admission that such reference is available as prior art to the present invention.

## WHAT IS CLAIMED IS:

1. An optical resizing device, comprising:
  - a first optical resizing element having a plurality of waveguides designed and constructed to provide optical resizing in a first dimension; and
  - a second optical resizing element, having a plurality of waveguides designed and constructed to provide optical resizing in a second dimension, said second optical resizing element being coupled to said first optical resizing element such that light exiting said first optical resizing element enters said second optical resizing element, hence being resized in both said first and said second dimensions;wherein said plurality of waveguides of at least one of said first optical resizing element and said second optical resizing element are at least partially tapered.
  
2. The optical resizing device of claim 1, wherein said plurality of waveguides of at least one of said first optical resizing element and said second optical resizing element are formed and/or embedded in a substrate in a longitudinally expanding arrangement such as to provide said optical resizing.
  
3. An optical resizing device, comprising:
  - a first optical resizing element having a plurality of waveguides designed and constructed to provide optical resizing in a first dimension; and
  - a second optical resizing element, having a plurality of waveguides designed and constructed to provide optical resizing in a second dimension, said second optical resizing element being coupled to said first optical resizing element such that light exiting said first optical resizing element enters said second optical resizing element, hence being resized in both said first and said second dimensions;wherein said plurality of waveguides of at least one of said first optical resizing element and said second optical resizing element are formed and/or embedded in a substrate in a longitudinally expanding arrangement such as to provide said optical resizing.

4. The optical resizing device of claim 3, wherein said plurality of waveguides of at least one of said first optical resizing element and said second optical resizing element are at least partially tapered.

5. The device of claim 2 or 3, wherein said longitudinally expanding arrangement comprises layers of waveguides, each layer being arranged such that the waveguides extend from a first region of said layer to a second region of said layer thereby defining a circumferential boundary within said layer, wherein the length characterizing said circumferential boundary is smaller at said first region than at said second region, such as to provide said optical resizing.

6. An optical resizing element comprising a plurality of layers forming a substrate having a first facet and a second facet being larger than said first facet, each layer of said plurality of layers having an arrangement of substantially parallel waveguides formed and/or embedded in said layer and extending from a first region of said layer to a second region of said layer, said plurality of layers arranged in a partially overlapping optical arrangement whereby the second region of each layer is optically exposed at said second facet such as to provide optical resizing in one dimension.

7. An optical resizing element comprising a substrate formed of at least one layer, each layer of said at least one layer having an arrangement of waveguides formed and/or embedded in said layer and extending from a first region of said layer to a second region of said layer thereby defining a circumferential boundary within said layer, wherein the length characterizing said circumferential boundary is smaller at said first region than at said second region, such as to provide optical resizing in one dimension.

8. The optical resizing element of claim 6 or 7, wherein at least a few of said plurality of waveguides are at least partially tapered.

9. The device or optical resizing element of claim 5, 6 or 7, wherein said first region and said second region are located at opposite sides of said layer.

10. The device or optical resizing element of claim 9, wherein said first region and said second region are parallel.

11. The device or optical resizing element of claim 5 or 7, wherein said first region and said second region are located at adjacent sides of said layer.

12. The device or optical resizing element of claim 11, wherein said first region and said second region are substantially orthogonal.

13. The device or optical resizing element of claim 5 or 7, wherein said first region and said second region are located at the same side of said layer.

14. The device or optical resizing element of claim 13, wherein said first region and said second region are substantially collinear.

15. The device of claim 1 or 3, wherein at least one of said first optical resizing element and said second optical resizing element comprises a slanted layer for providing said optical resizing.

16. The device of claim 1 or 3, wherein at least one of said first optical resizing element and said second optical resizing element comprises a terrace for providing said optical resizing.

17. The device of claim 1 or 3, wherein at least one of said optical resizing element is designed and constructed such that said light enters said optical resizing element while propagating in a first direction and exit said optical resizing element while propagating in said first direction.

18. The device of claim 1 or 3, wherein at least one of said optical resizing element is designed and constructed such that said light enters said optical resizing element while propagating in a first direction and exit said optical resizing element while propagating in a second direction being different from said first direction.

19. The device of claim 1 or 3, wherein each of said first optical resizing element and said second optical resizing element independently comprises a first facet and a second facet being different in size than said first facet, whereby said plurality of waveguides extends from said first facet to said second facet.

20. The device of claim 19, wherein said second facet is substantially parallel to said first facet.

21. The device of claim 19, wherein said second facet is substantially orthogonal to said first facet.

22. The device of claim 19, wherein said second facet is tilted with respect to said first facet.

23. The device of claim 19, wherein said second facet and said first facet are substantially coplanar.

24. The device of claim 1 or 3, wherein said first optical resizing element is constructed and designed to receive light from a plurality of sources and transmitting said light into said second optical resizing element.

25. The optical resizing element of claim 6 or 7, being constructed and designed to receive light from a plurality of sources and transmitting said light into said second optical resizing element.

26. The device of claim 1 or 3, further comprising at least one additional optical resizing element constructed and designed to receive light from at least one additional light source and transmitting said light into said second optical resizing element.

27. The device of claim 26, wherein said at least one additional light source comprises a monochrome light source.

28. The device of claim 24 or 26, wherein said second optical resizing element is designed and constructed to emit light originated from different sources to different directions.

29. The device of claim 1 or 3, wherein said second optical resizing element is designed and constructed to emit light received from said first optical resizing element to a plurality of directions.

30. The optical resizing element of claim 6 or 7, being designed and constructed to emit light to a plurality of directions.

31. The device of claim 1 or 3, wherein said first optical resizing element is constructed and designed to receive light from a single source and emit said light to at least two different directions.

32. The optical resizing element of claim 6 or 7, being constructed and designed to receive light from a single source and emit said light to at least two different directions.

33. The device of claim 31, further comprising at least one additional optical resizing element positioned at one of said at least two different directions and configured to receive light from said first optical resizing element.

34. The device or optical resizing element of claim 1, 3, 6, 7 or 19, further comprising a diffusive layer attached to or etched in said second facet.

35. The device of claim 1, 3, 15 or 16, wherein at least one of said first optical resizing element and said second optical resizing element comprises an expanding structure.

36. The device of claim 35, wherein said expanding structure comprises a holographic optical element.

37. The device of claim 35, wherein said expanding structure comprises a stack of layers alternately patterned with high refractive index regions and low refractive index regions.

38. The device of claim 35, wherein said expanding structure comprises a stack of layers patterned with grooves.

39. The device of claim 35, wherein said expanding structure comprises a stack of layers of tapered waveguides.

40. The device of claim 35, wherein said expanding structure comprises mirrors.

41. The device of claim 40, wherein said mirrors comprise total internal reflection mirrors.

42. The device of claim 40, wherein said mirrors are coated by high reflection coat.

43. The device of claim 35, wherein said expanding structure comprises Bragg reflectors.

44. The device of claim 1 or 3, wherein at least one of said first optical resizing element and said second optical resizing element comprises a plurality of partial optical resizing elements whereby each partial optical resizing element is designed and constructed to provide partial optical resizing in a respective dimension.

45. The device of claim 1 or 3, wherein at least one of said first optical resizing element and said second optical resizing element is designed and constructed to polarize light.

46. The optical resizing element of claim 6 or 7, being designed and constructed to polarize light.

47. An optical resizing device, comprising:  
a plurality of layers forming a substrate having a first facet and a second facet, said plurality of layers being arranged in a partially overlapping optical arrangement;  
each layer of said plurality of layers having an arrangement of waveguides formed and/or embedded in said layer and extending from a first region of said layer to a second region of said layer thereby defining a circumferential boundary within said layer, wherein the length characterizing said circumferential boundary is smaller at said first region than at said second region, and wherein said second region is optically exposed at said second facet.
48. The device of claim 47, wherein said first facet is defined by ends of overlapping regions of said plurality of layers.
49. The device of claim 47, wherein each layer is partially exposed at said first facet.
50. The device of claim 47, wherein at least a few of said plurality of waveguides are at least partially tapered.
51. The device of claim 47, wherein at least a few layers of said plurality of layers comprise mirrors for redirecting light propagating within said plurality of waveguides out of said layer.
52. The device of claim 51, wherein at least a portion of said mirrors are total internal reflection mirrors.
53. The device of claim 51, wherein at least a portion of said mirrors are etched mirrors.
54. The device of claim 51, wherein at least a portion of said mirrors are coated by a high reflective coat.

55. The device of claim 51, wherein at least a portion of said mirrors comprise planar facet.

56. The device of claim 51, wherein at least a portion of said mirrors comprise non-planar facet.

57. The device of claim 47, wherein at least a few layers of said plurality of layers comprise Bragg reflectors for redirecting light propagating within said plurality of waveguides out of said layer.

58. The device of claim 47, wherein at least a few layers of said plurality of layers comprise holographic optical elements for redirecting light propagating within said plurality of waveguides out of said layer.

59. The device of claim 1, 3 or 47, being characterized by a field-of-view selected sufficiently small so as to substantially preserve brightness of light being resized by the device.

60. A method of manufacturing an optical resizing element, comprising:

(a) forming on a substrate a plurality of waveguides in an expanding arrangement extending from a first region of said substrate to a second region of said substrate, thereby providing a layer of waveguides;

(b) repeating said step (a) a plurality of times, thereby providing a plurality of layers; and

(c) stacking said plurality of layers so as to form a first facet, defined by ends of said plurality of layers, and a second facet, defined by an exposed surface of one of said plurality of layers;

thereby manufacturing the optical resizing element.

61. The method of claim 60, further comprising:

(d) forming on a substrate a plurality of substantially parallel waveguides extending from a first region of said substrate to a second region of said substrate, thereby providing a layer of waveguides;

(e) repeating said step (d) a plurality of times, thereby providing a plurality of layers;

(f) stacking said plurality of layers in a partially overlapping optical arrangement whereby the second region of each layer is optically exposed, so as to form a first facet and a second facet, said second facet being defined by optically exposed portion of said plurality of layers;

thereby manufacturing a second optical resizing element; and

(g) optically coupling said optical resizing element to said second optical resizing element so as to allow propagation of light from said optical resizing element to said second optical resizing element, wherein said light is resized in a first dimension within said optical resizing element and in a second dimension within said second optical resizing element.

62. A method of manufacturing a plurality of optical resizing elements, comprising:

(a) forming on a substrate a plurality of waveguides extending from a first region of said substrate to a second region of said substrate, thereby providing a layer of waveguides;

(b) repeating said step (a) a plurality of times, thereby providing a plurality of layers;

(c) stacking said plurality of layers so as to provide a stack; and

(d) performing at least one cut to said stack so as to provide a plurality of optical resizing elements.

63. A method of manufacturing an optical resizing element, comprising:

(a) forming on a substrate a plurality of parallel waveguides extending from a first region of said substrate to a second region of said substrate, thereby providing a layer of waveguides;

(b) repeating said step (a) a plurality of times, thereby providing a plurality of layers; and

(c) stacking said plurality of layers in a partially overlapping optical arrangement whereby the second region of each layer is optically exposed, so as to

form a first facet and a second facet, said second facet being defined by optically exposed portion of said plurality of layers;

thereby manufacturing the optical resizing element.

64. The method of claim 60 or 63, further comprising:

(d) repeating said steps (b)-(c) so as to form a second optical resizing element; and

(e) optically coupling said optical resizing element to said second optical resizing element so as to allow propagation of light from said optical resizing element to said second optical resizing element, wherein said light is resized in a first dimension within said optical resizing element and in a second dimension within said second optical resizing element.

65. A method of manufacturing an optical resizing device, comprising:

(a) forming on a substrate a plurality of waveguides extending from a first region of said substrate to a second region of said substrate thereby defining a circumferential boundary within said substrate, wherein the length characterizing said circumferential boundary is smaller at said first region than at said second region;

(b) repeating said step (a) a plurality of times, thereby providing a plurality of layers; and

(c) stacking said plurality of layers in a partially overlapping optical arrangement whereby the second region of each layer is optically exposed, so as to form a first facet and a second facet, said second facet being defined by optically exposed portion of said plurality of layers, thereby manufacturing the optical resizing device.

66. The method of claim 60, 62, 63 or 65, wherein said forming said plurality of waveguides comprises forming a plurality of tapered waveguides.

67. The method of claim 62, 63 or 65, further comprising positioning mirrors for redirecting light propagating within said plurality of waveguides out of said substrate.

68. The method of claim 60, 63 or 65, further comprising cutting said plurality of layers, subsequently to said step of stacking said plurality of layers, so as to form at least one of said first facet and said second facet.

69. The method of claim 68, wherein said cutting is performed such that at least one of said first facet and said second facet is slanted.

70. The method of claim 60, 63 or 65, further comprising cutting said plurality of layers, prior to said step of stacking said plurality of layers, so as to form, for each layer, a layer end exposing a plurality of waveguides ends.

71. The method of claim 60, 62, 63 or 65, further comprising depositing a polarizer on at least a portion of said layers, prior to said step of stacking said plurality of layers.

72. The method of claim 60, 63 or 65 further comprising coupling at least one of said first facet and said second facet to a coupler.

73. The method of claim 72, wherein said coupler comprises a microlens array.

74. The method of claim 60, 63 or 65 further comprising etching at least one of said first facet and said second facet so as to form a microlens array on said facet.

75. The optical resizing device, optical resizing element or method of claim 6, 47, 61, 63 or 65 wherein said plurality of layers are partially exposed at said second facet.

76. The optical resizing device, optical resizing element or method of claim 2, 3, 6, 7, 47, 60, 63 or 65 wherein at least a few of said plurality of waveguides form a planar light circuit.

77. The optical resizing device, optical resizing element or method of claim 2, 3, 6, 7, 47, 60, 63 or 65 wherein at least a few of said plurality of waveguides form an optical fibers array.

78. The optical resizing device, optical resizing element or method of claim 76, wherein at least a few of said plurality of waveguides are single mode waveguides.

79. The optical resizing device, optical resizing element or method of claim 76, wherein at least a few of said plurality of waveguides are multimode waveguides.

80. The optical resizing device or optical resizing element of claim 76, further comprising light absorbers introduced between cores of said waveguides.

81. The optical resizing device, optical resizing element or method of claim 2, 3, 6, 7, 47, 60, 63 or 65 wherein at least a few of said plurality of waveguides comprise a core and a cladding said core having a higher refractive index than said cladding.

82. The optical resizing device, optical resizing element or method of claim 2, 3, 6, 7, 47, 60, 63 or 65, wherein at least a few of said plurality of waveguides comprise photonic bandgap material.

83. The optical resizing device or optical resizing element of claim 2, 3, 6, 7 or 47, further comprising a microlens array for coupling the light into said optical resizing device or optical resizing element.

84. The optical resizing device or optical resizing element of claim 2, 3, 6, 7 or 47, further comprising at least one fiber bundle for coupling the light into said optical resizing device or optical resizing element.

85. The optical resizing device, optical resizing element or method of claim 1, 4, 8, 39, 50 or 66, wherein said tapering is characterized by a smooth profile.

86. The optical resizing device, optical resizing element or method of claim 1, 4, 8, 39, 50 or 66, wherein said tapering is characterized by a substantially stepped profile.

87. The optical resizing device or optical resizing element of claim 1, 3, 6, 7 or 47, being flexible.

88. The optical resizing device or optical resizing element of claim 1, 3, 6, 7 or 47, being foldable.

89. The optical resizing device or optical resizing element of claim 1, 3, 6, 7 or 47, serving as a component in a display system.

90. The optical resizing device or optical resizing element of claim 1, 3, 6, 7 or 47, serving as a component in a autostereoscopic display system.

91. A method of resizing a spot of light, comprising, transmitting the light through the optical resizing device of any of the preceding claims.

92. The method of claim 91, further comprising distorting the spot of light such as to provide a brightness gradient thereacross thereby compensating non homogenous optical losses.

93. The method of claim 91, wherein said light constitutes an image.

94. The method of claim 93, further comprising distorting said image such as to provide a brightness gradient thereacross thereby compensating non homogenous optical losses.

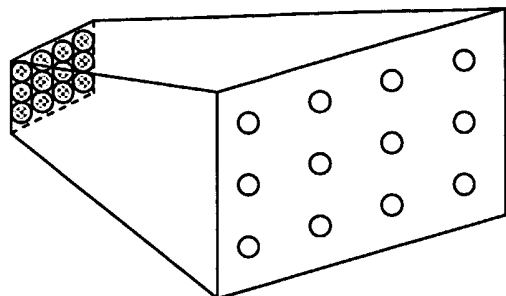

Fig. 1a (Prior Art)

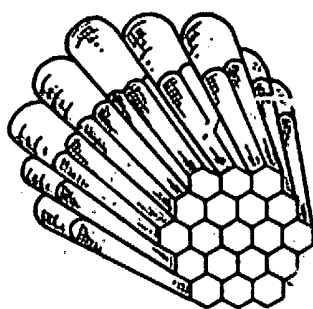

Fig. 1b (Prior Art)

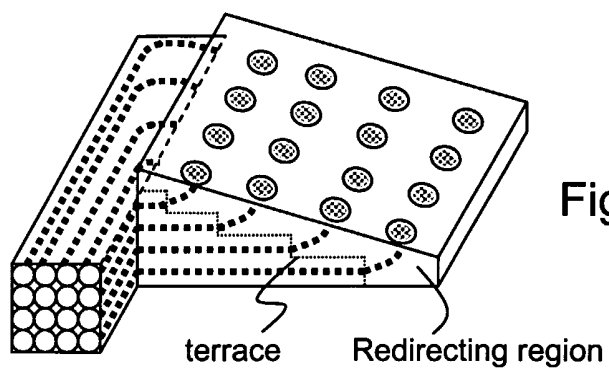

Fig. 1c (Prior Art)

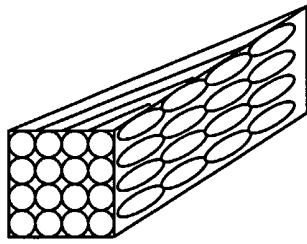

Fig. 2a (Prior Art)

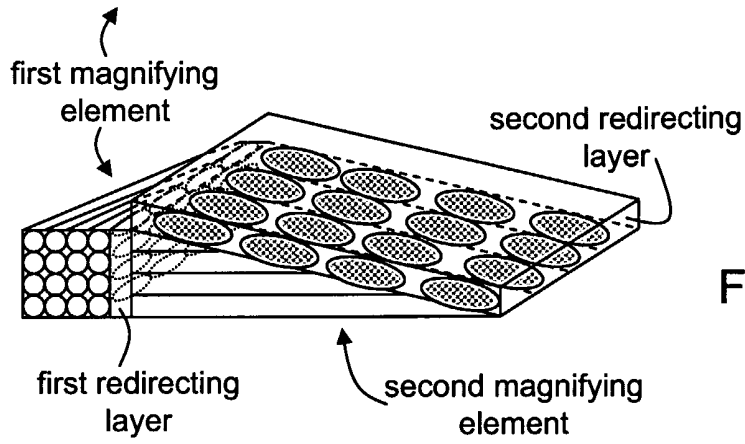

Fig. 2b (Prior Art)

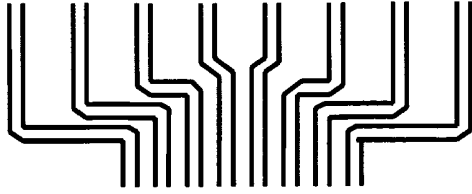

Fig. 3a

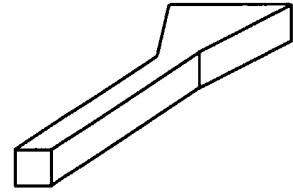

Fig. 3b

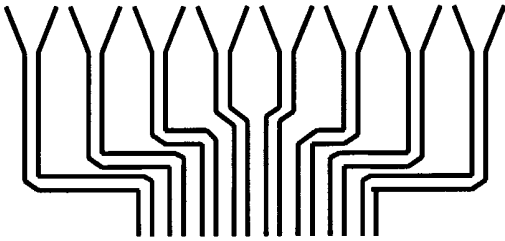

Fig. 3c

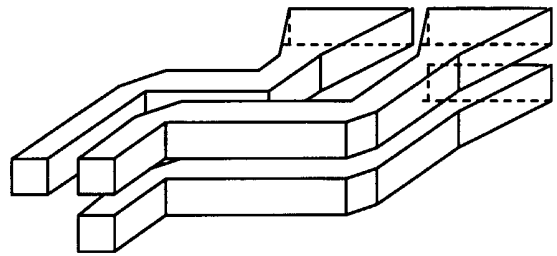

Fig. 3d

4/38

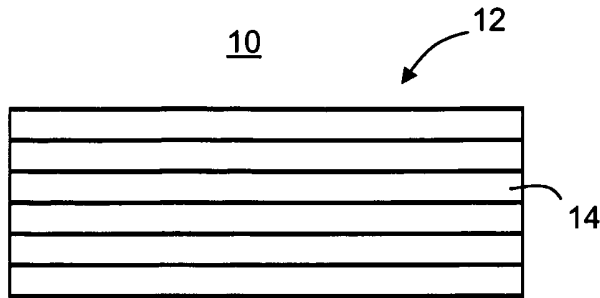

Fig. 4a

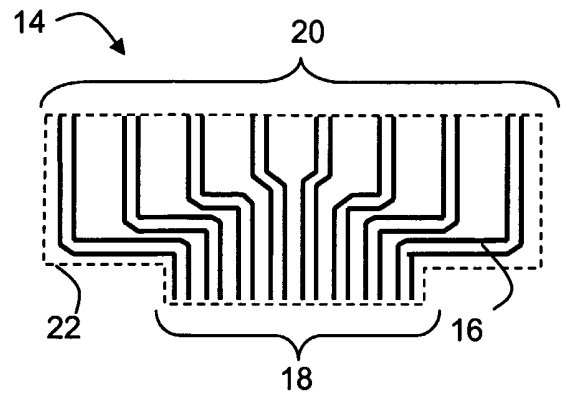
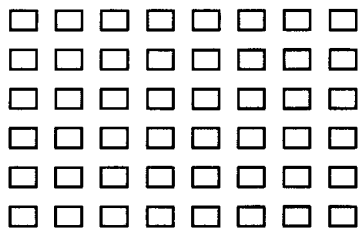
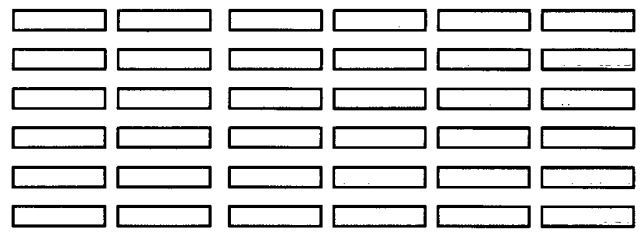

Fig. 4b



24

Fig. 4c



26

Fig. 4d

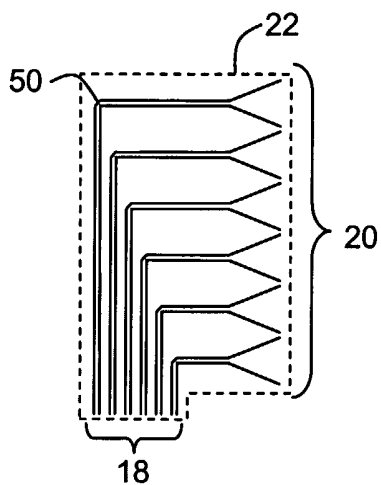

Fig. 4e

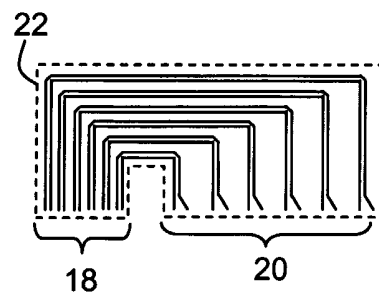

Fig. 4f

Fig. 4g

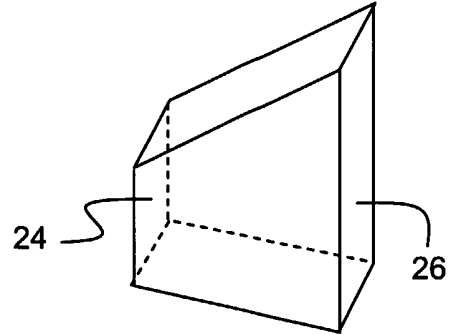

Fig. 4h

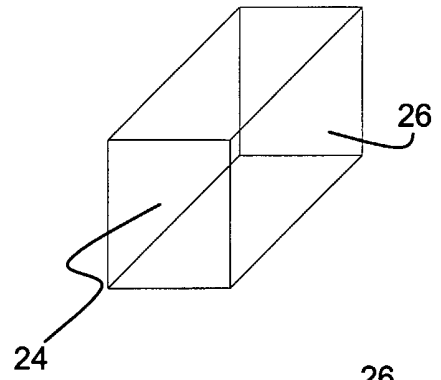

Fig. 4i

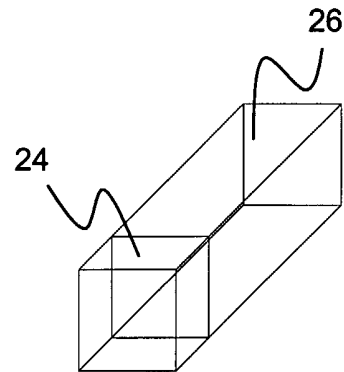

Fig. 5

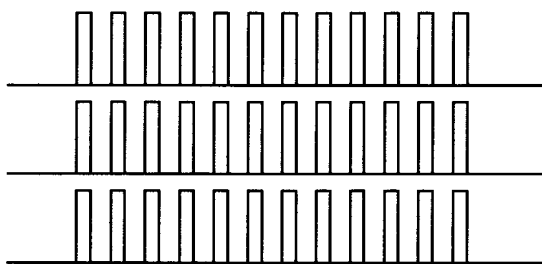
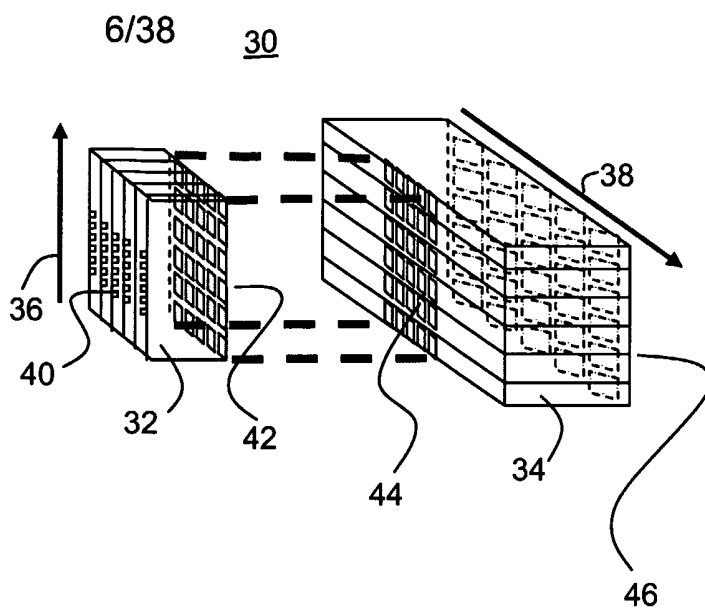

Fig. 6a

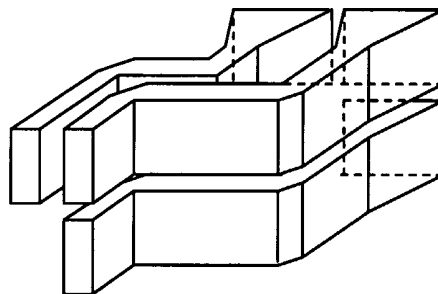

Fig. 6b

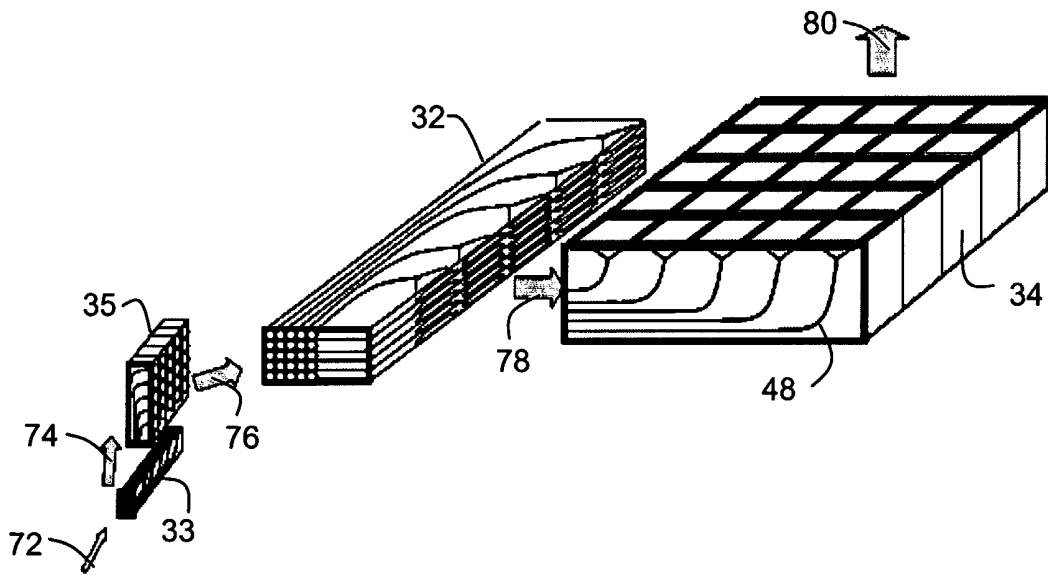
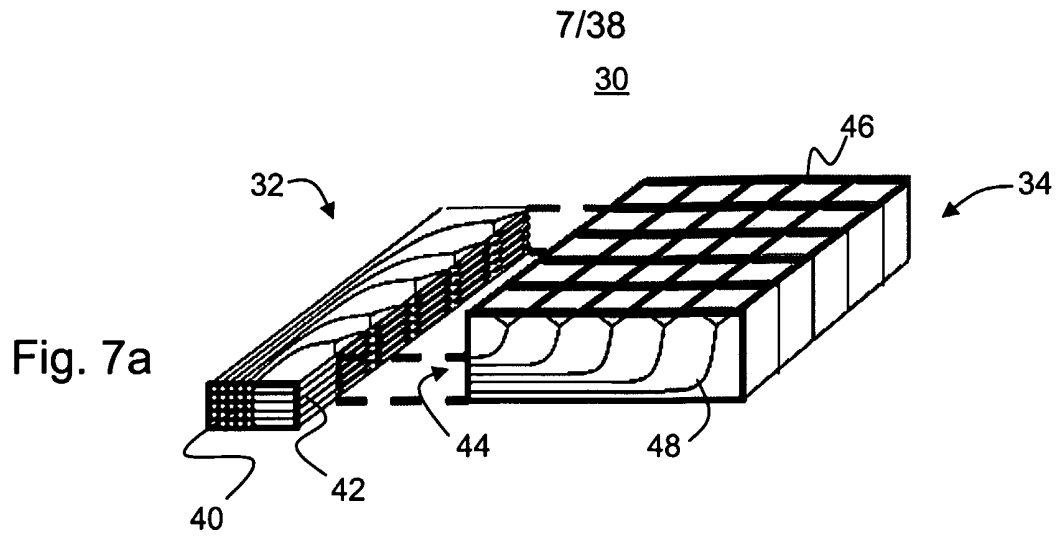

Fig. 7b

Fig. 8

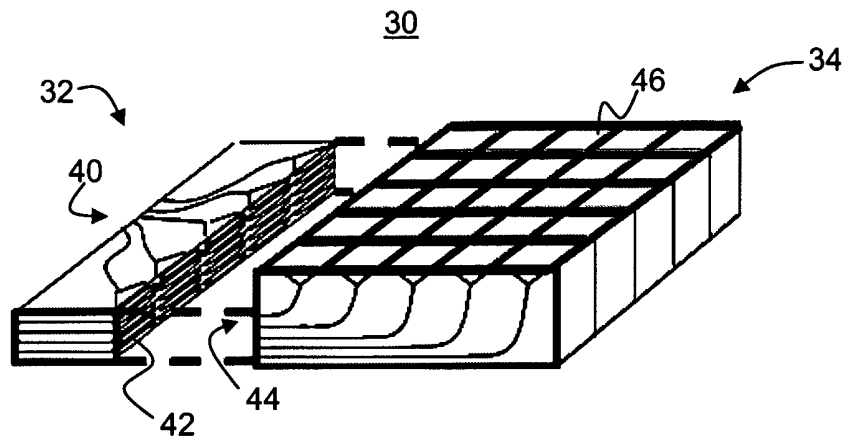
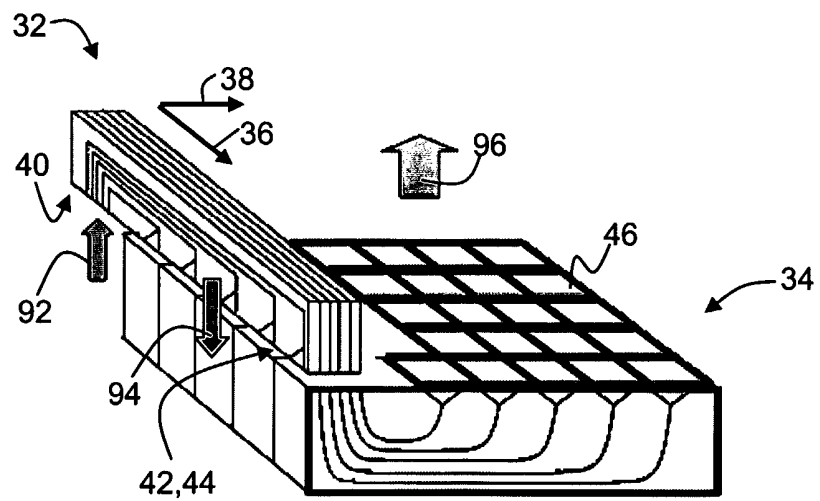

Fig. 9



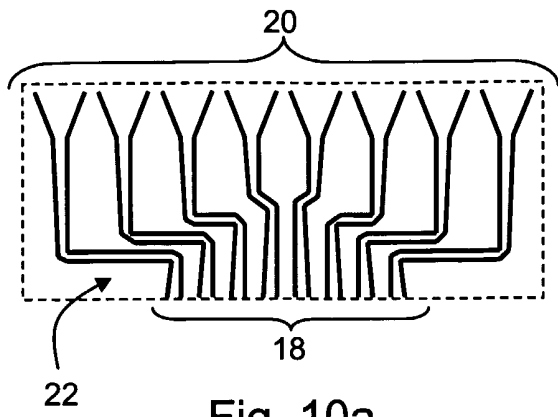

Fig. 10a

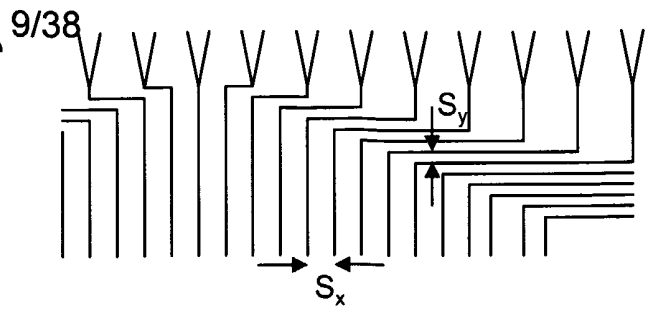

Fig. 10b

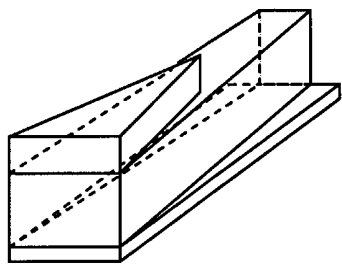

Fig. 11a

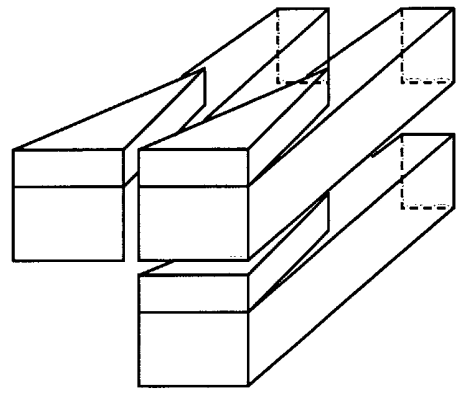

Fig. 11b

Fig. 12a

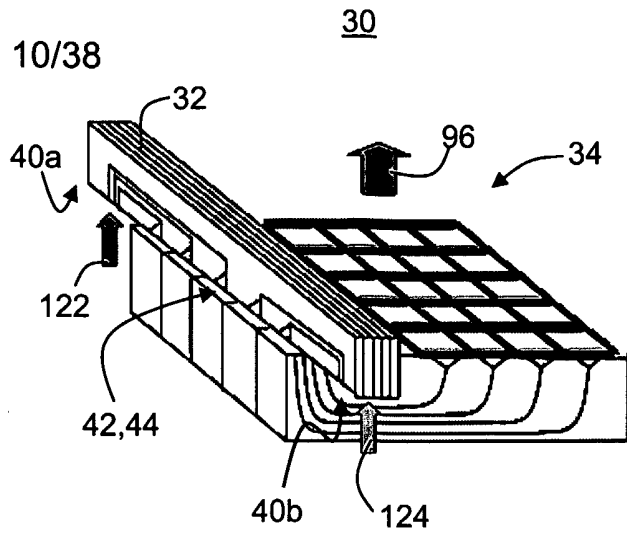

Fig. 12b

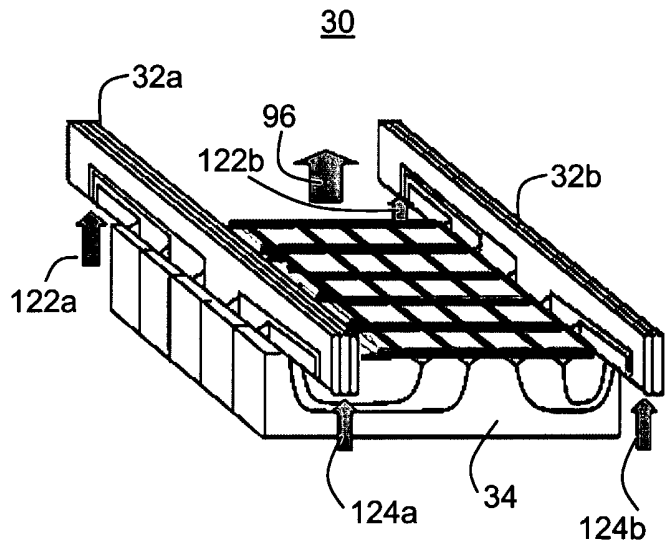
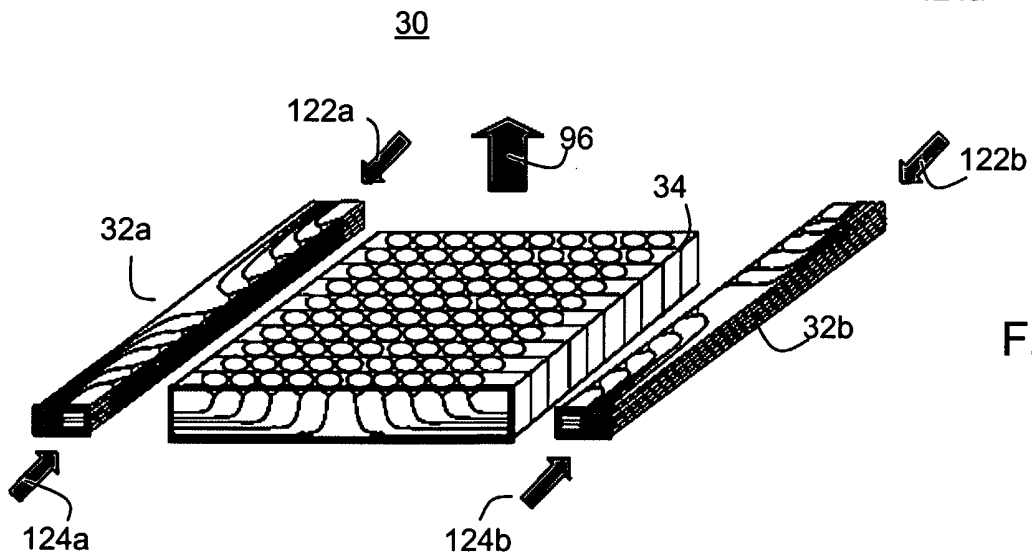

Fig. 12c



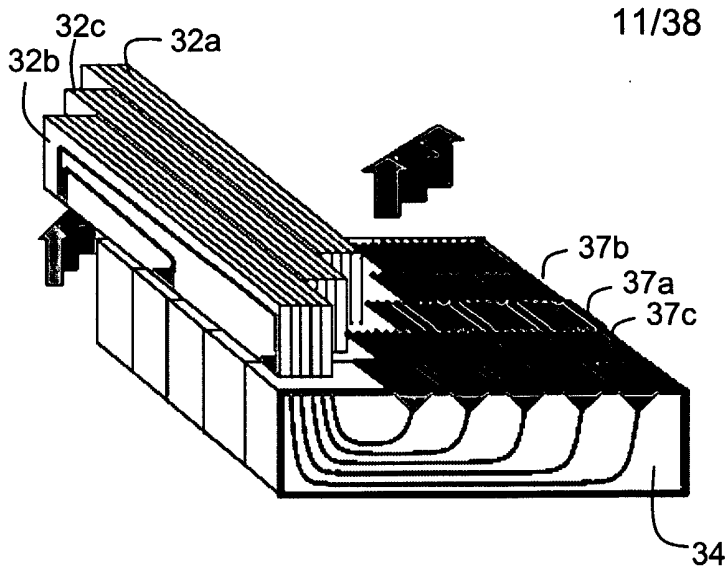

Fig. 12d

11/38

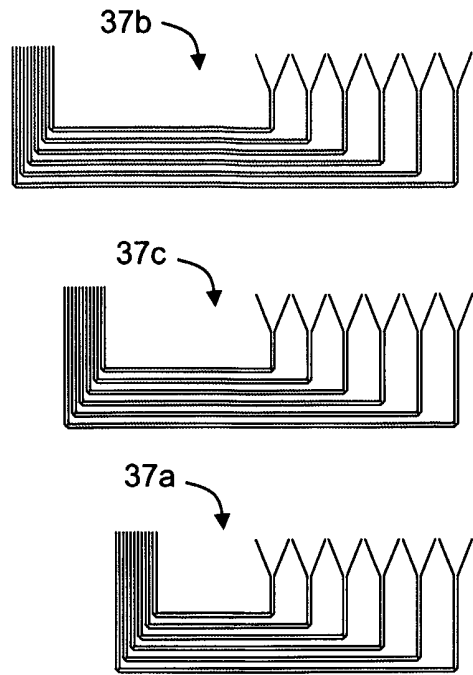

Fig. 12e

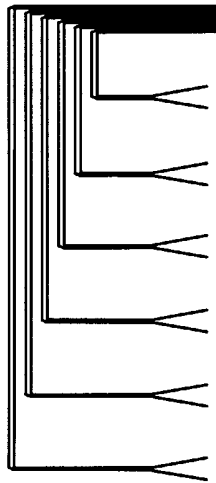

Fig. 12f

12/38<sub>30</sub>

Fig. 13a

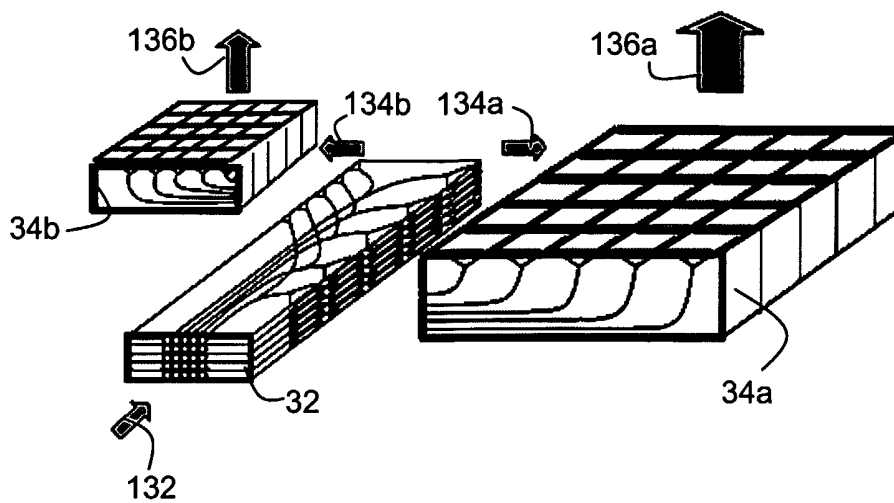

Fig. 13b

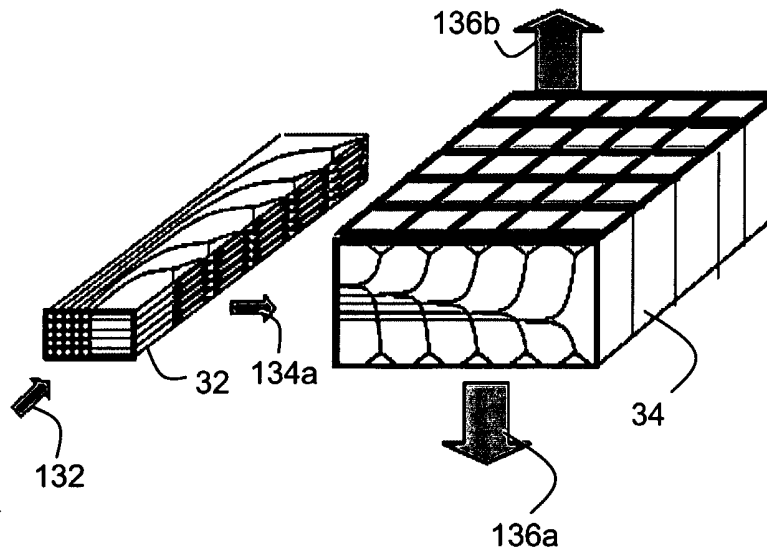
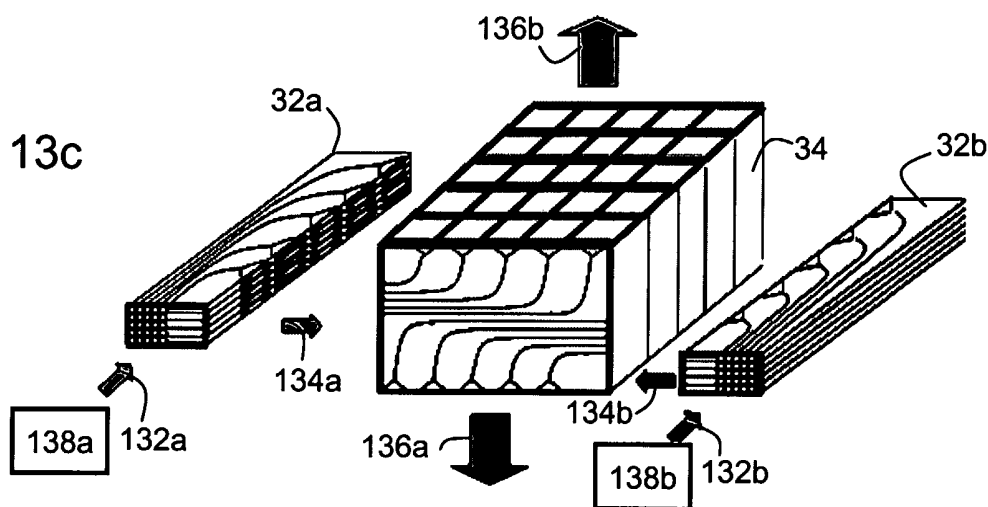

Fig. 13c



13/38

30

Fig. 14a

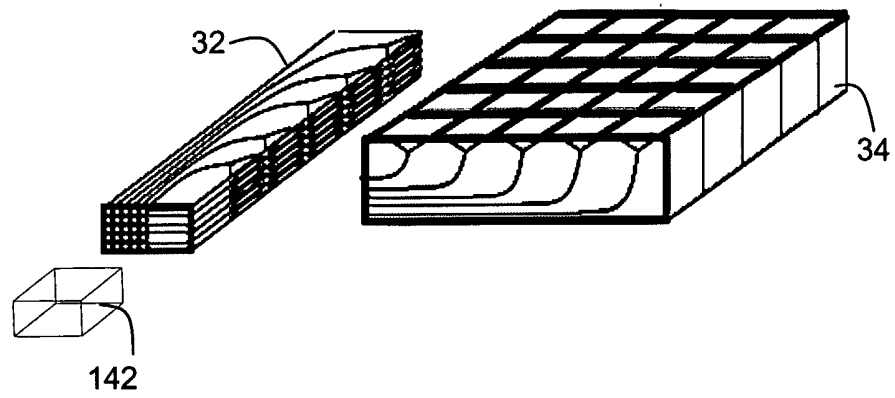

30

Fig. 14b

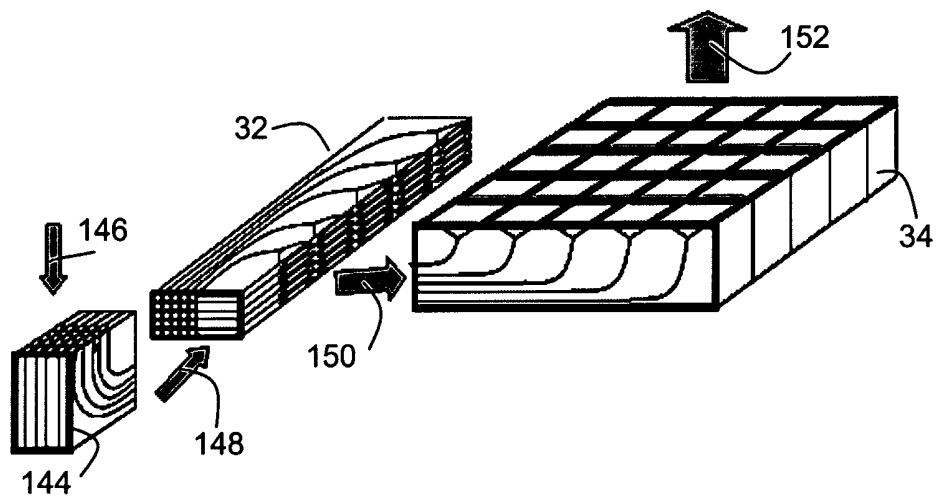

Fig. 15

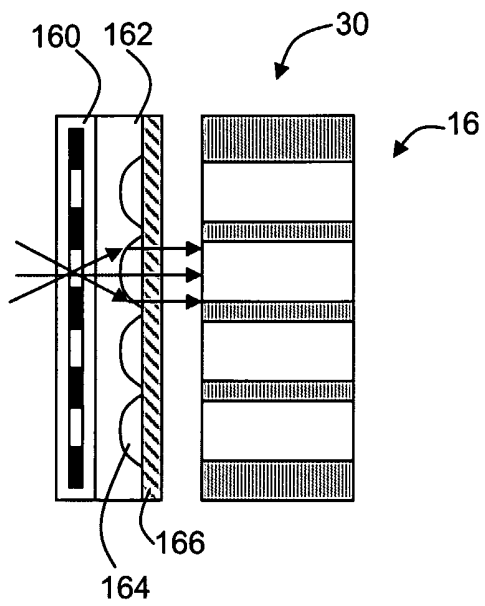
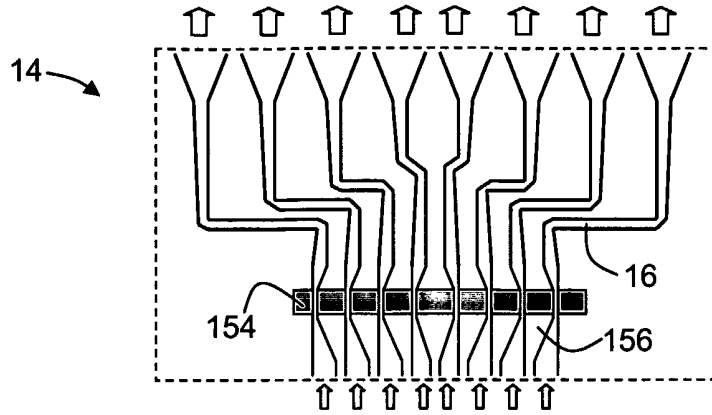

Fig. 16a

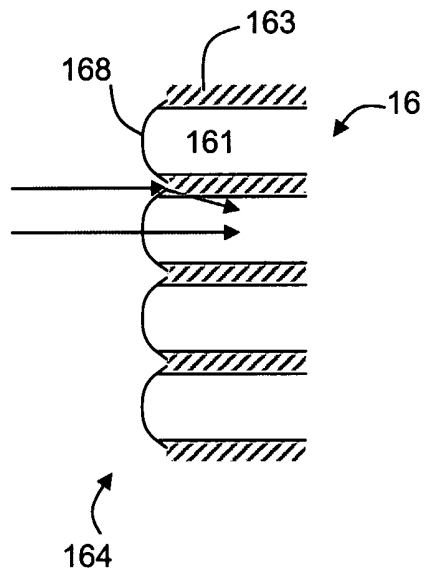

Fig. 16b

Fig. 17

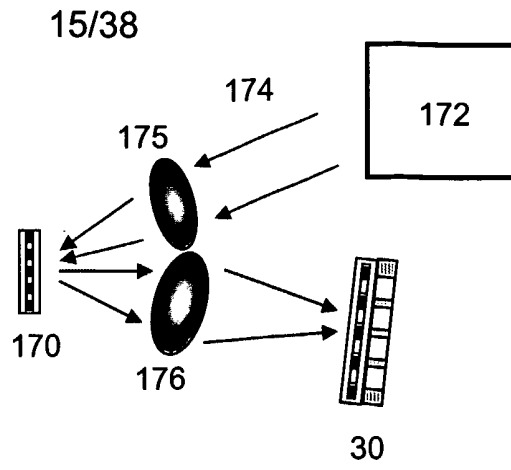

Fig. 18a

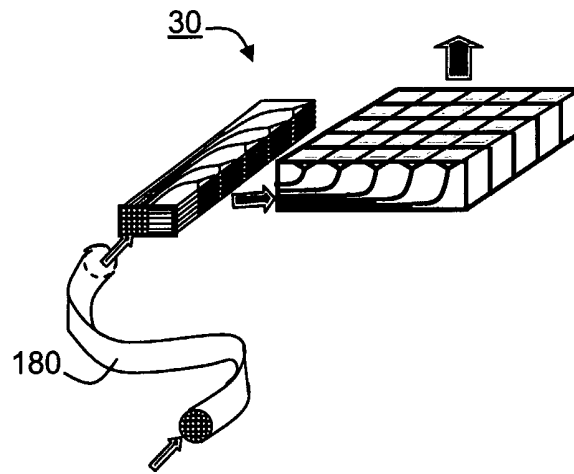
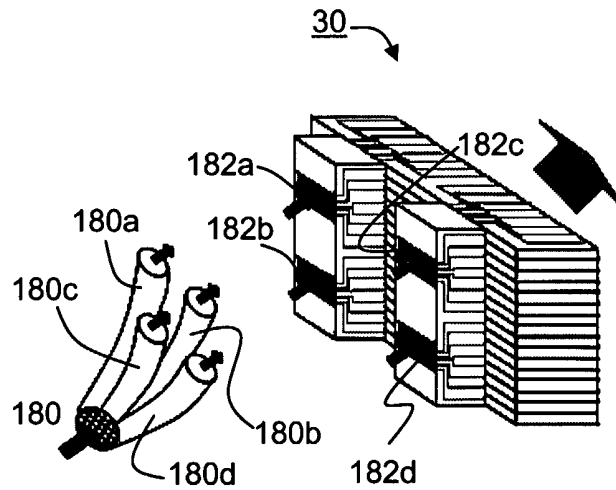

Fig. 18b



16/38

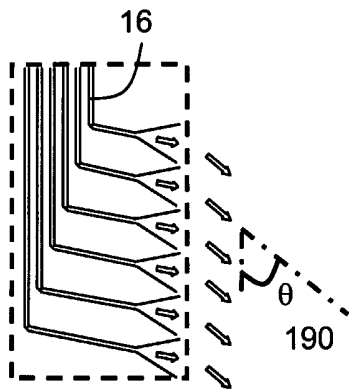

Fig. 19

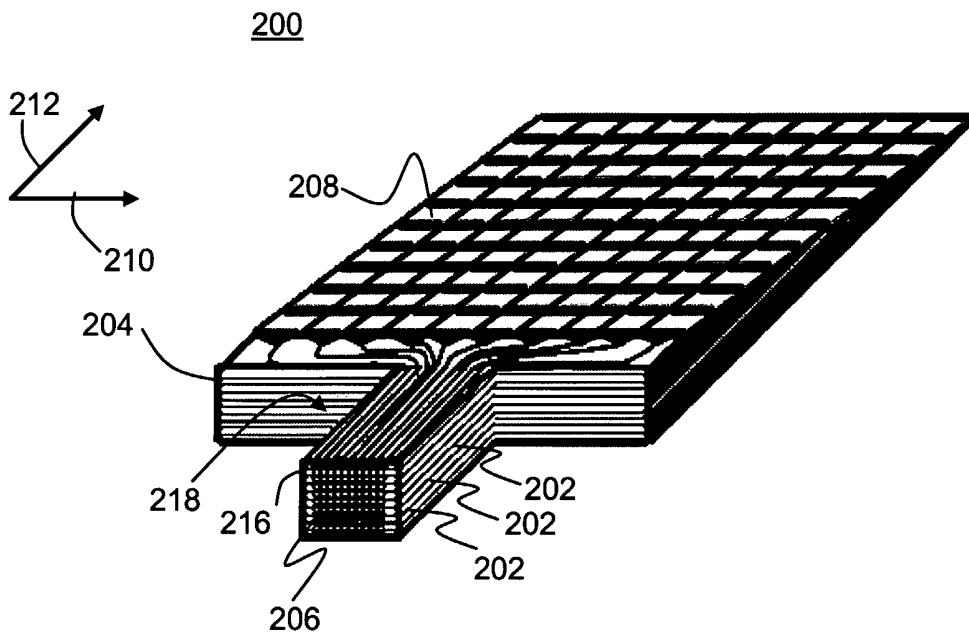

Fig. 20

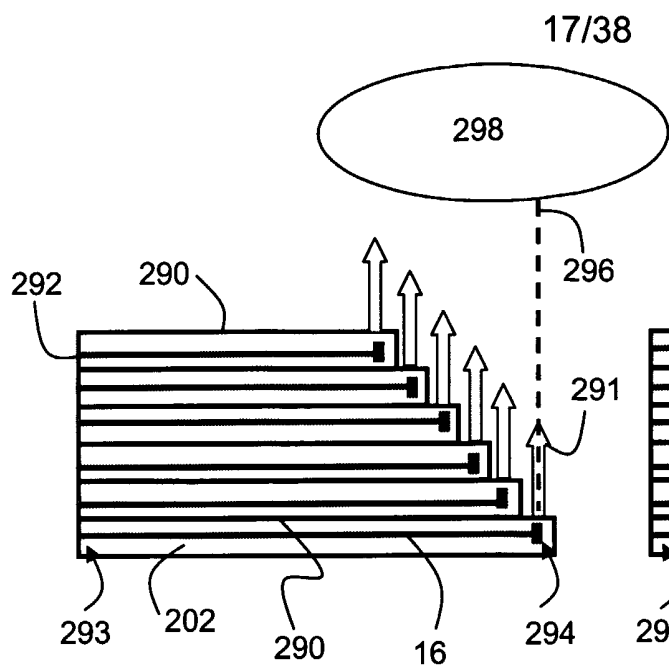

Fig. 21a

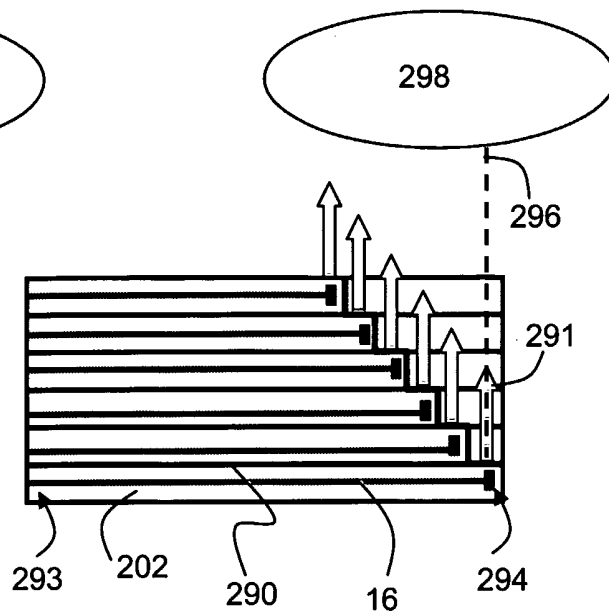

Fig. 21b

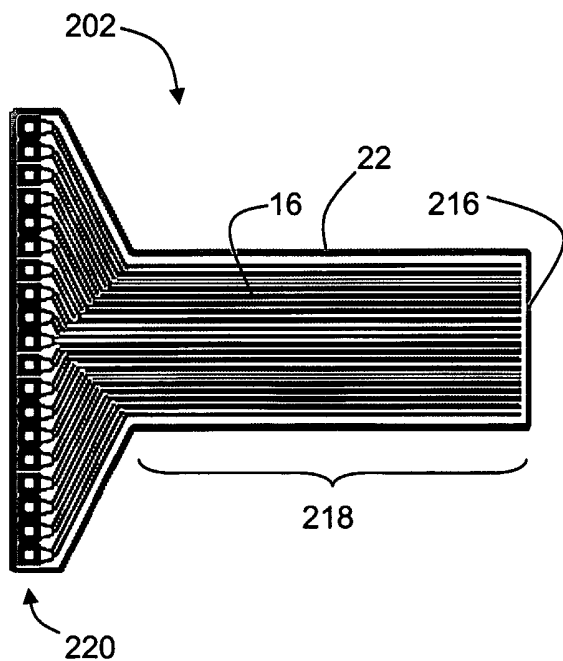

Fig. 21c

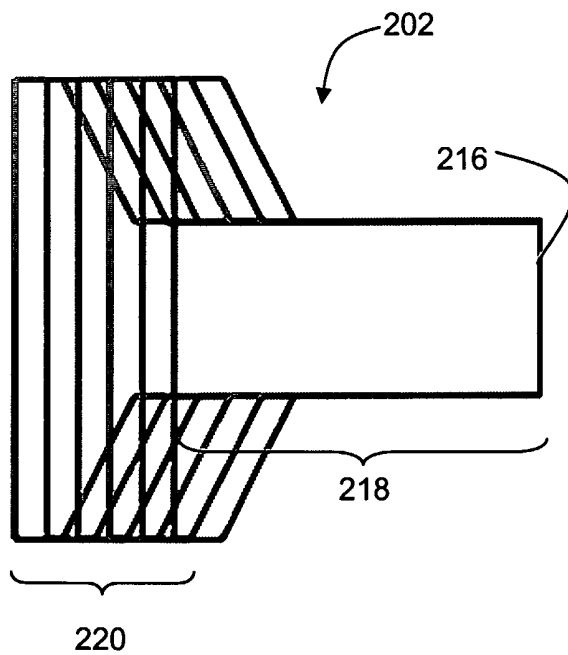

Fig. 21d

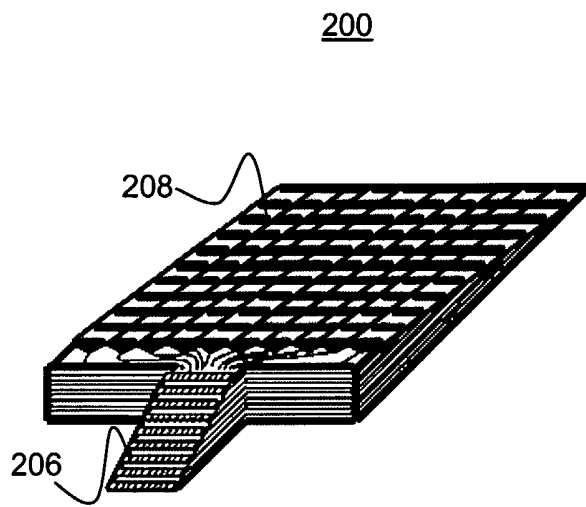

Fig. 22a

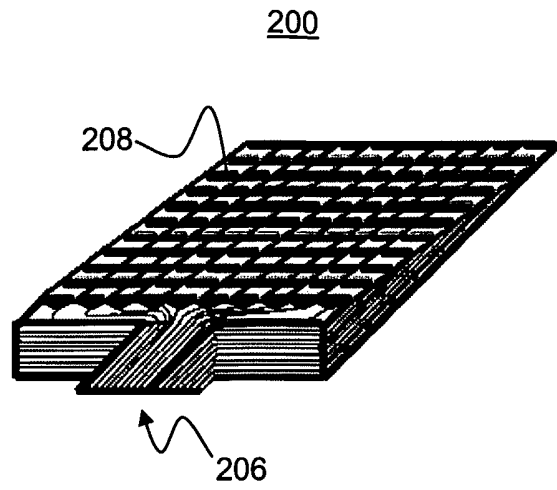

Fig. 22b

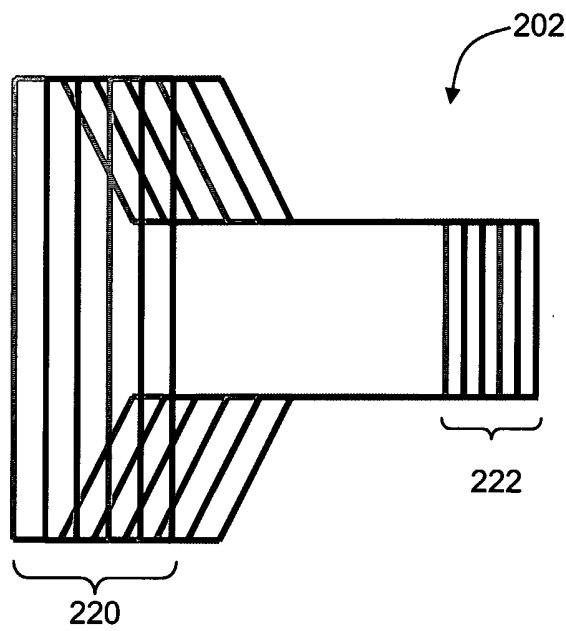

Fig. 22c

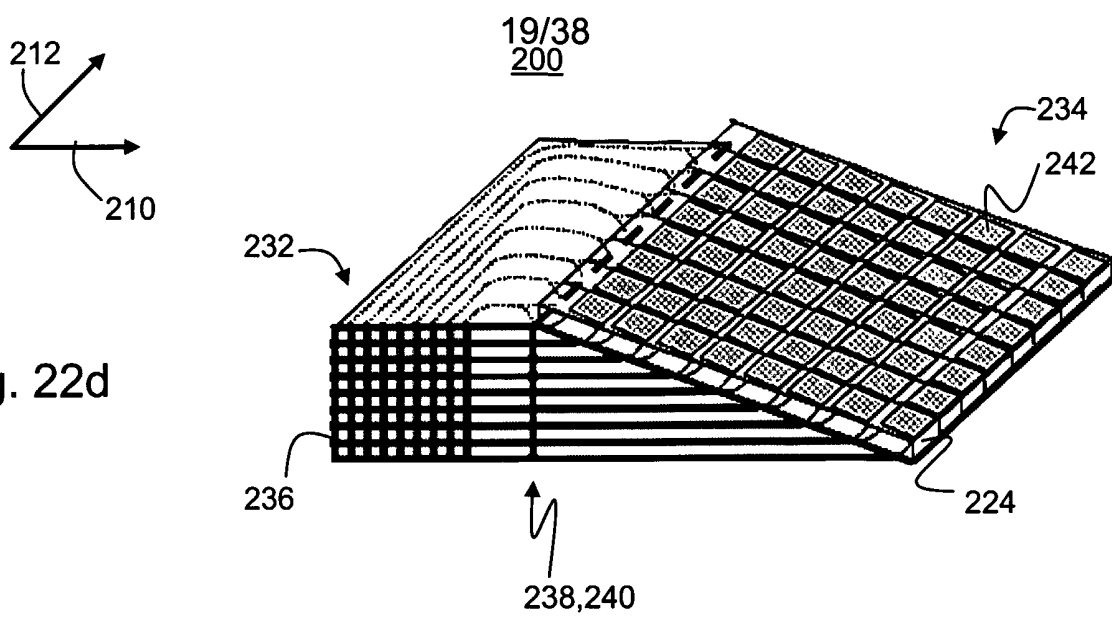

Fig. 22d

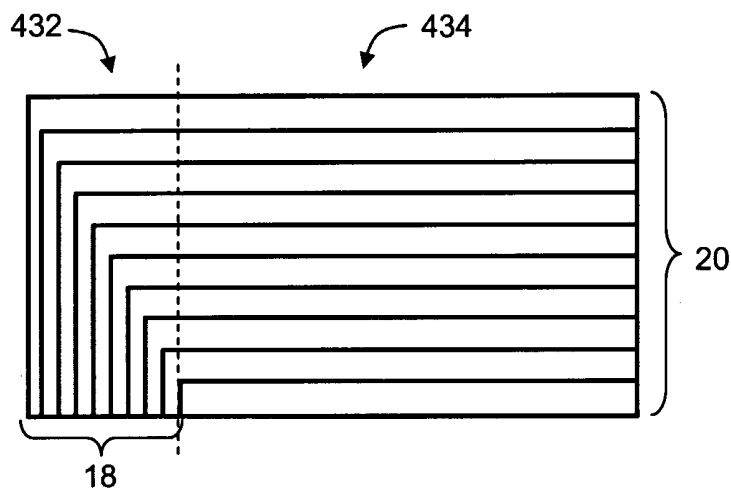

Fig. 22e

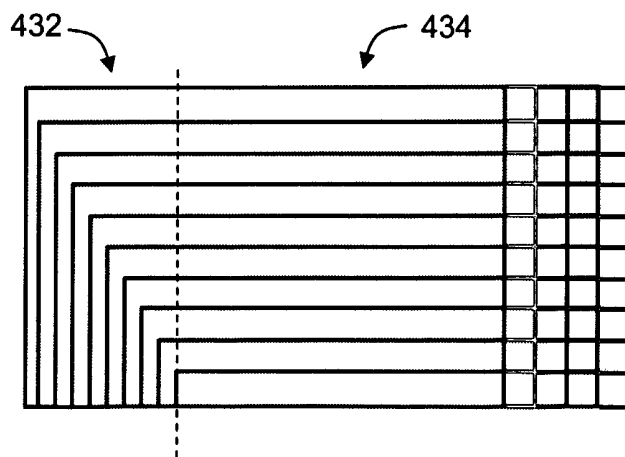

Fig. 22f

20/38

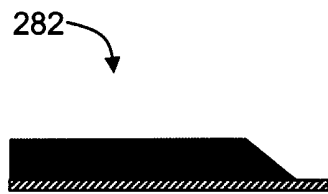
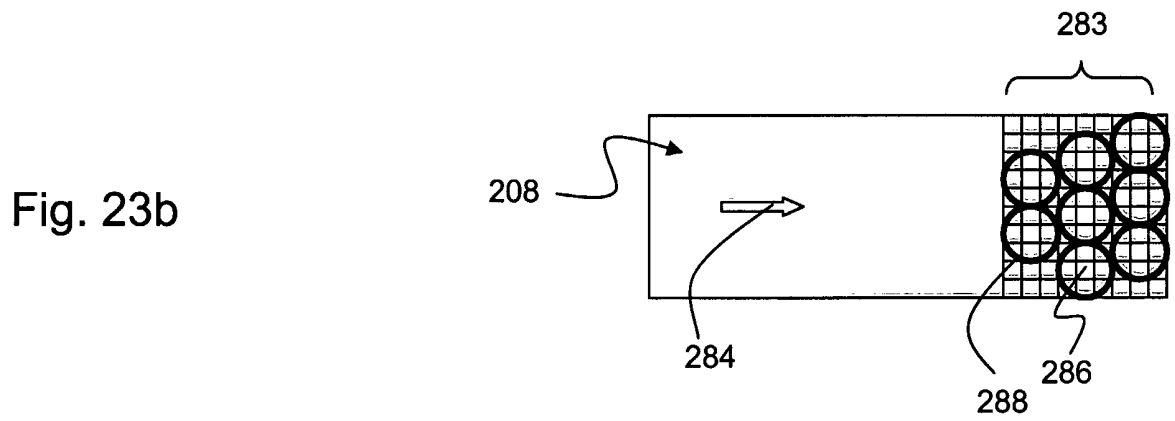
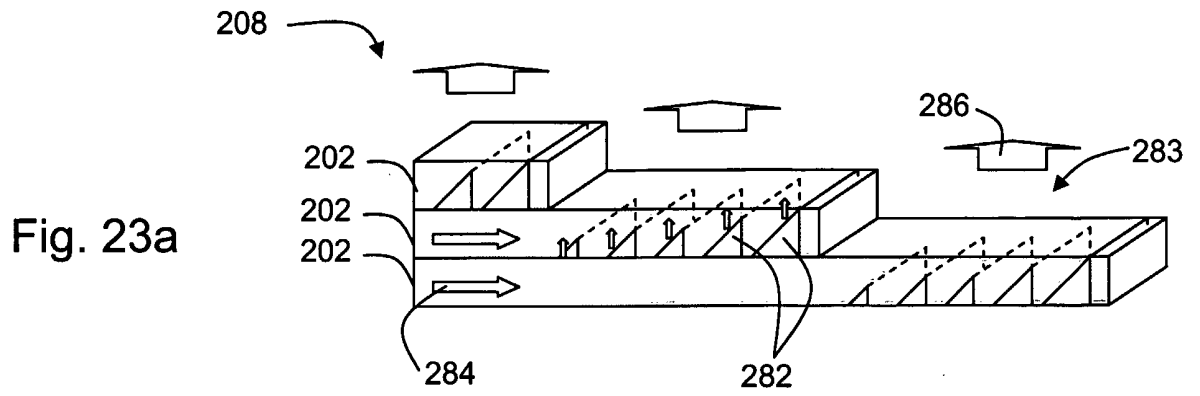

Fig. 23c

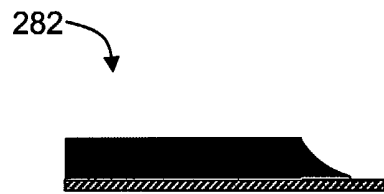

Fig. 23d

21/38

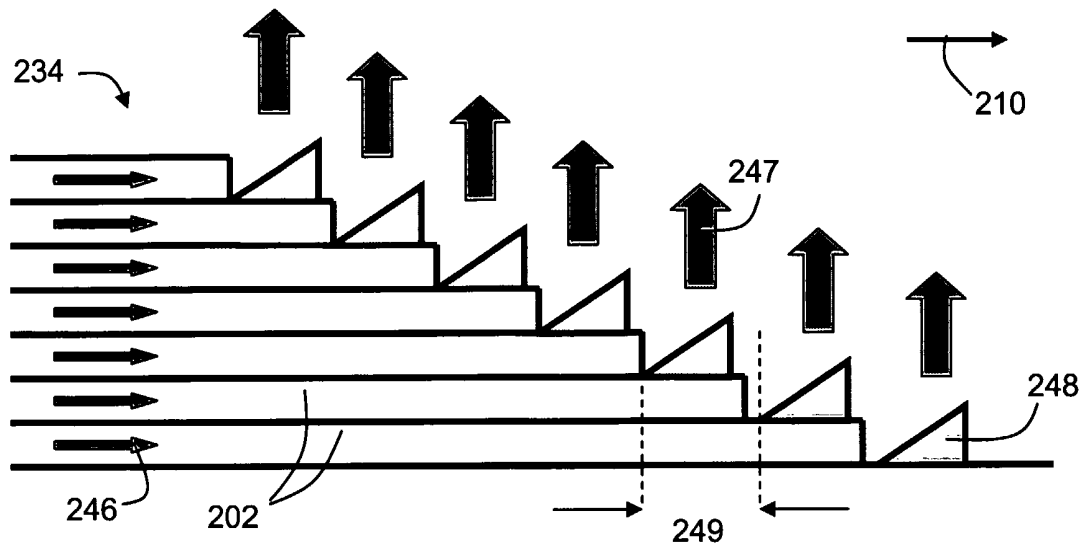

Fig. 24a

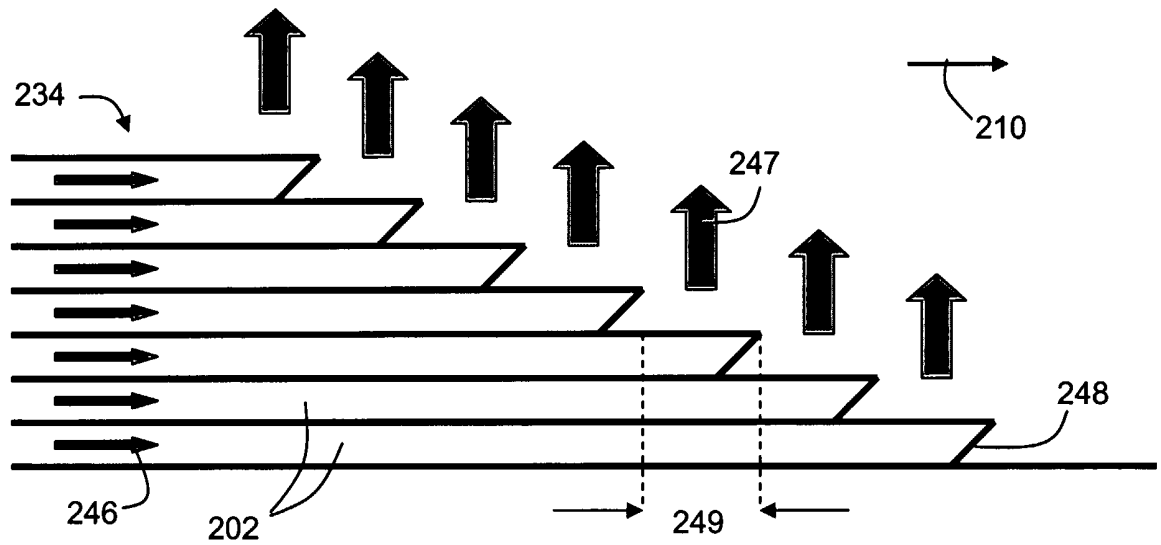

Fig. 24b

22/38

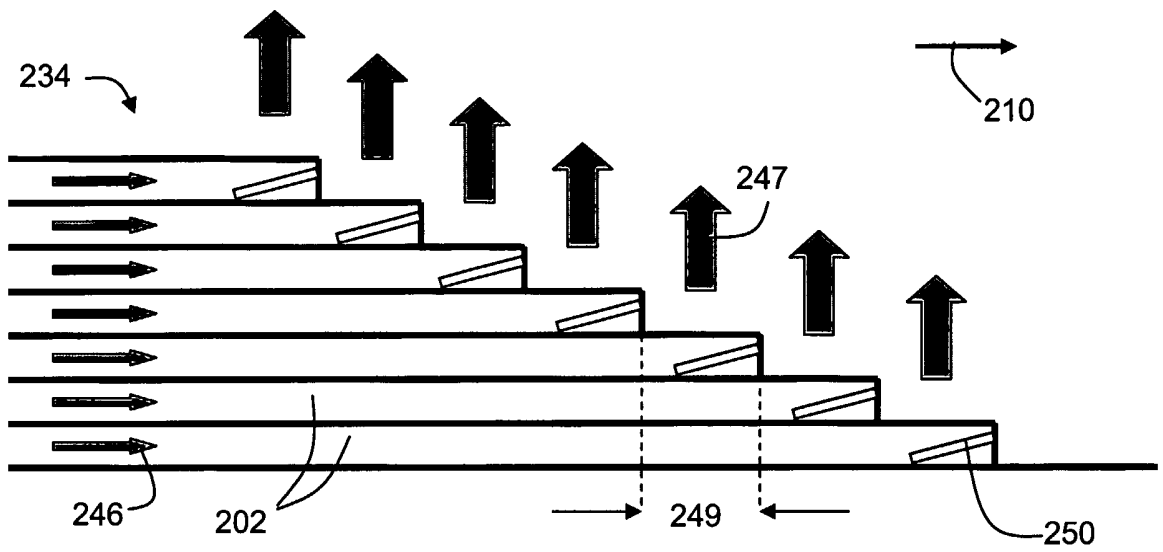

Fig. 24c

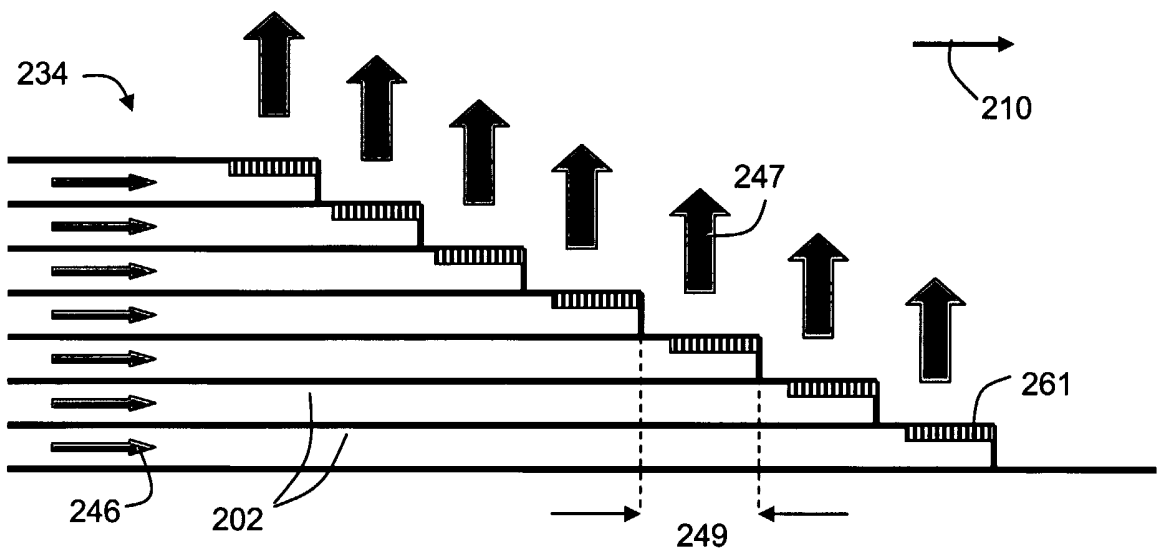

Fig. 24d

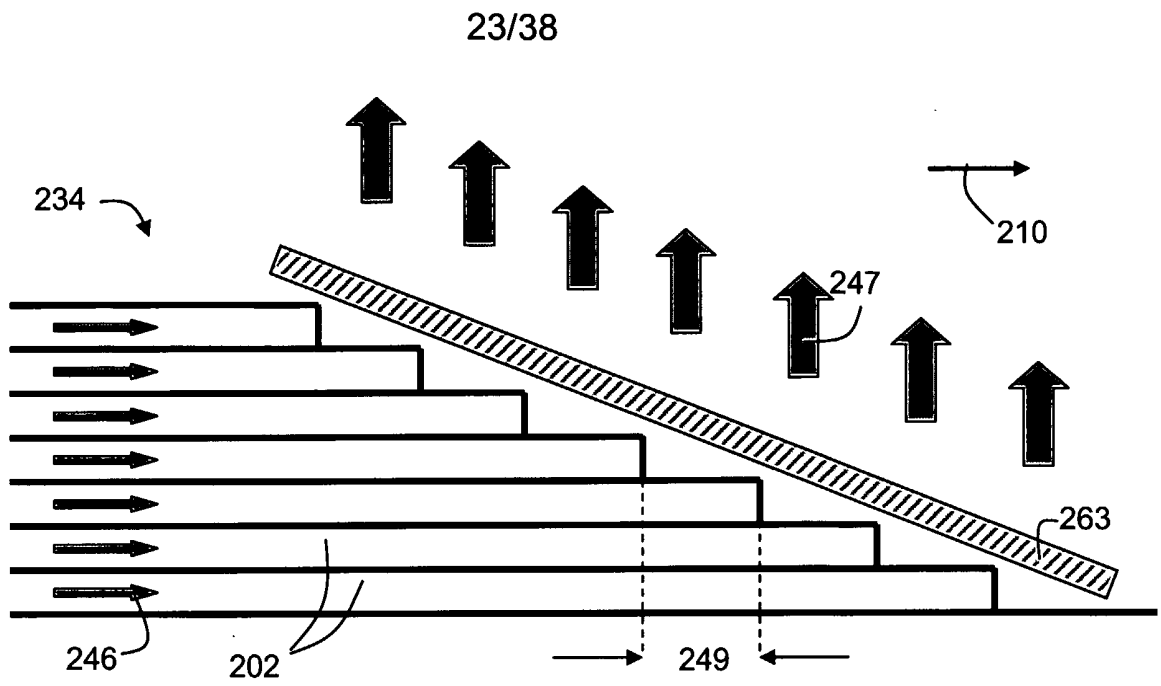

Fig. 24e

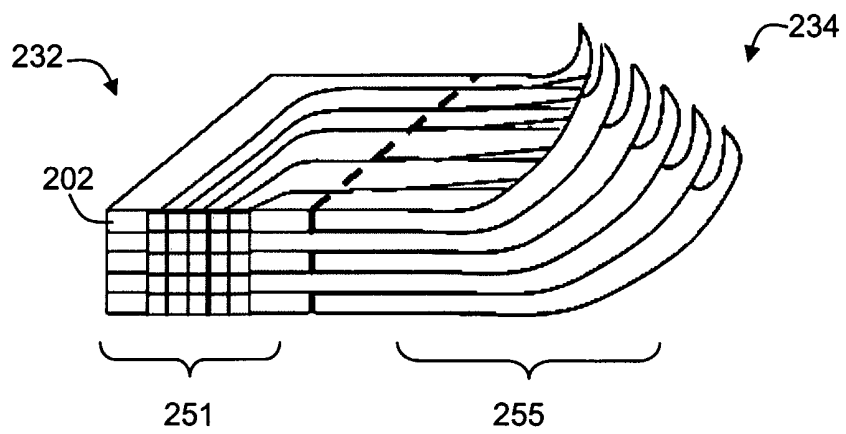
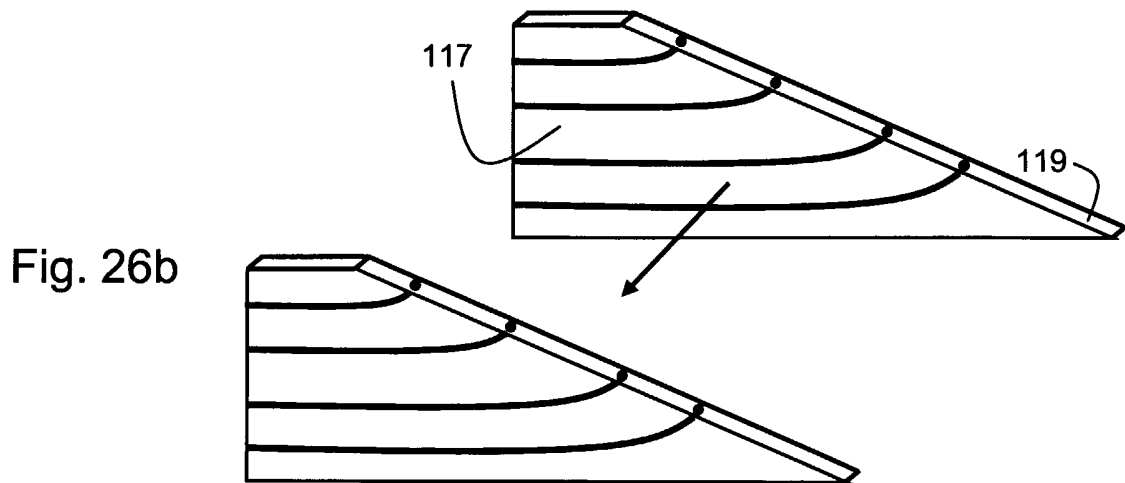
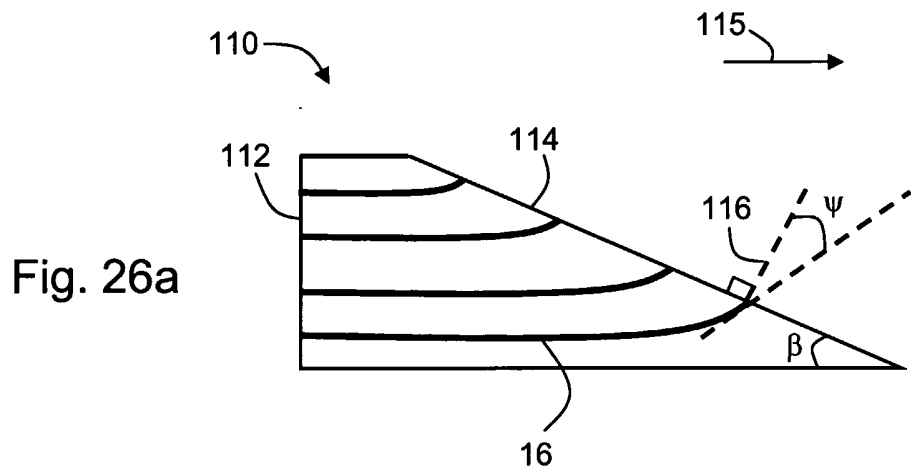

Fig. 25



25/38

Fig. 27a

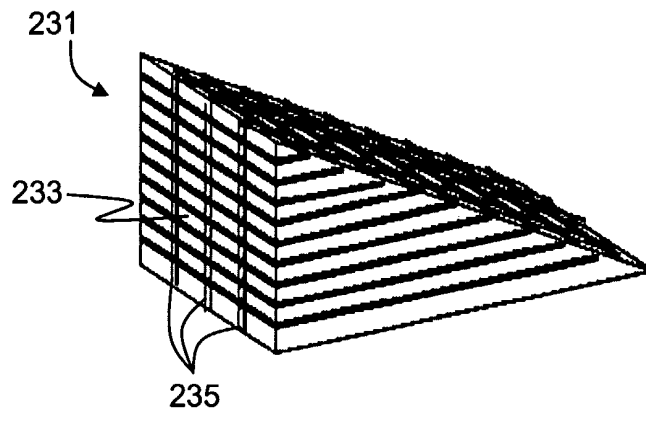
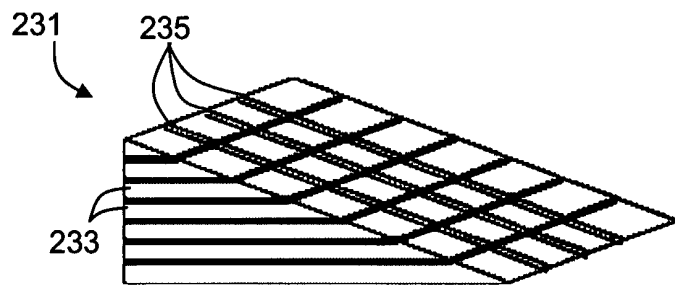

Fig. 27b



26/38

224

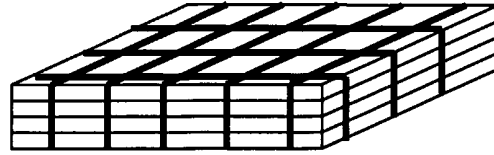

Fig. 27c

224

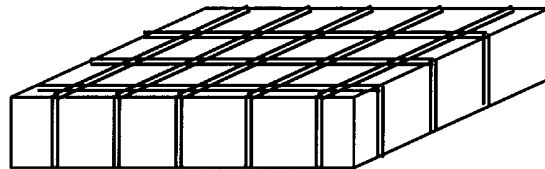

Fig. 27d

27/38

Fig. 27e

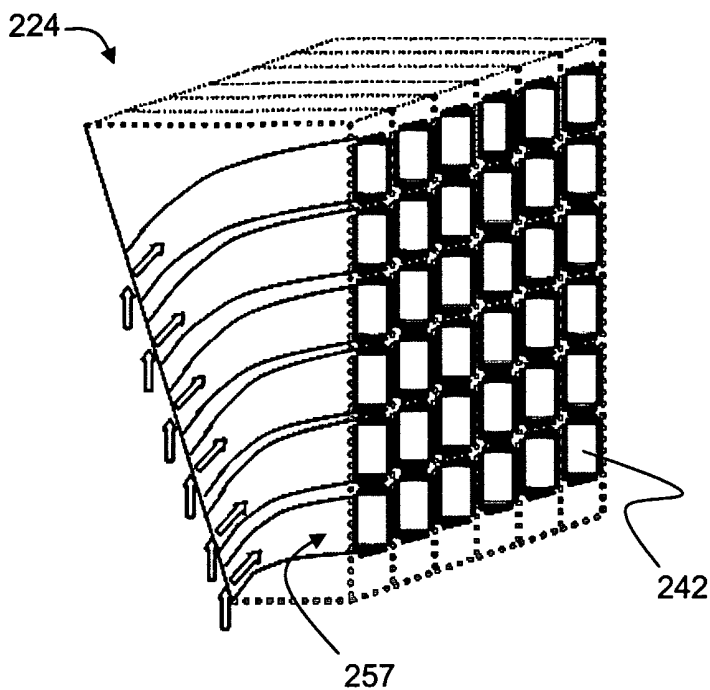
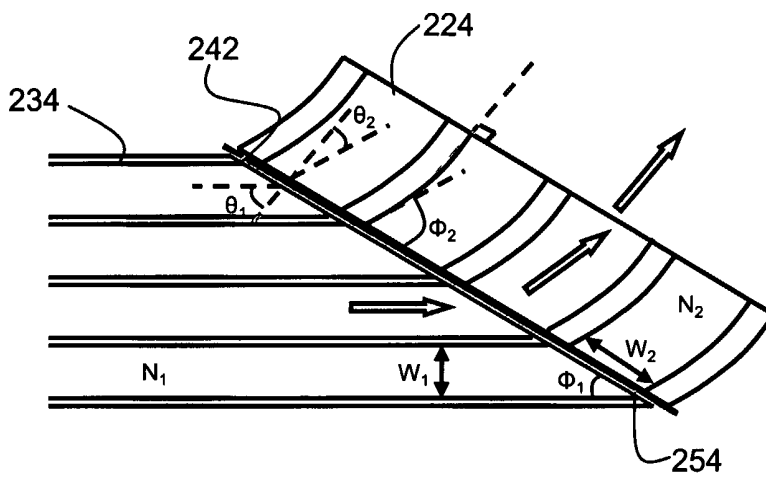

Fig. 27f



28/38

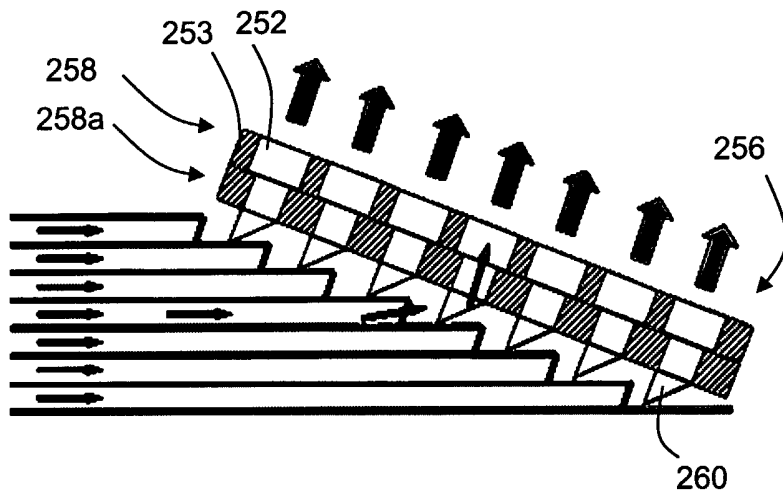

Fig. 27g

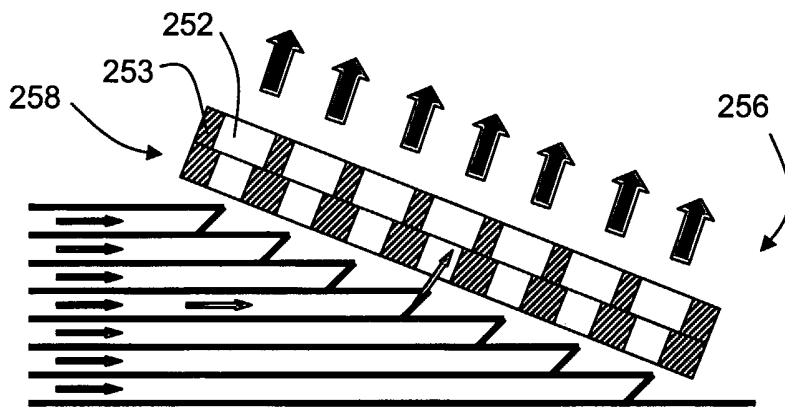

Fig. 27h

Fig. 28a

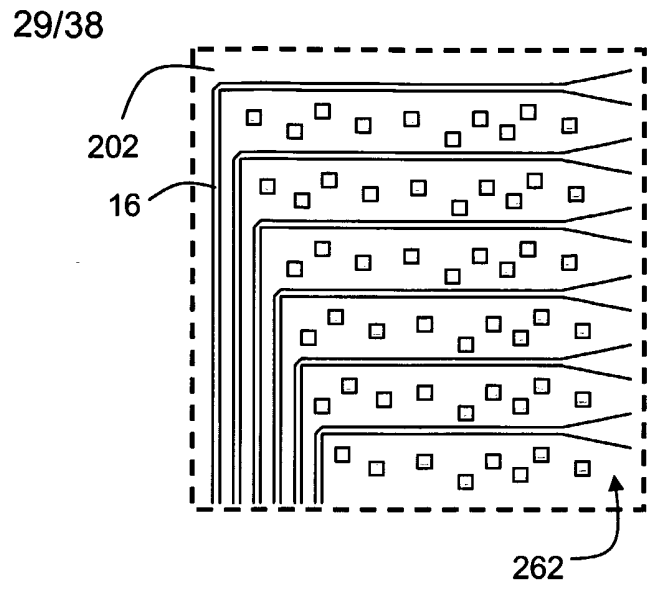

Fig. 28b

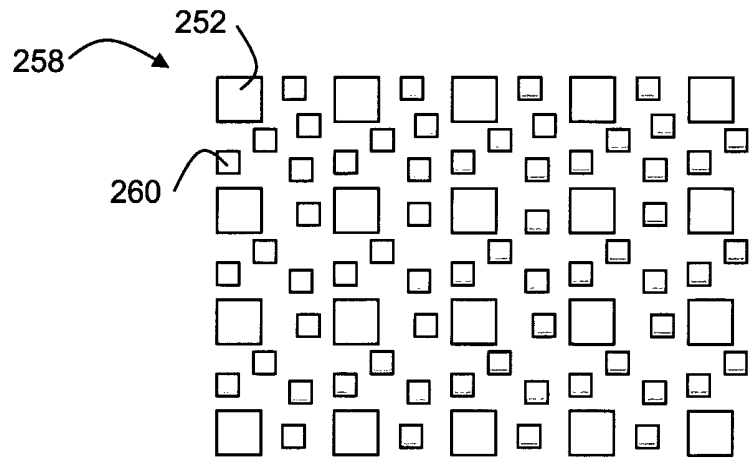
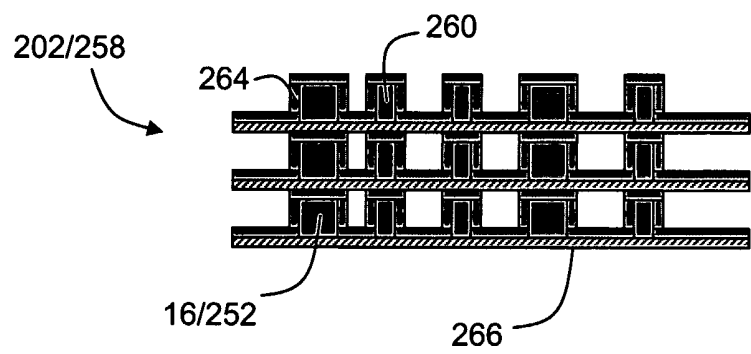

Fig. 28c



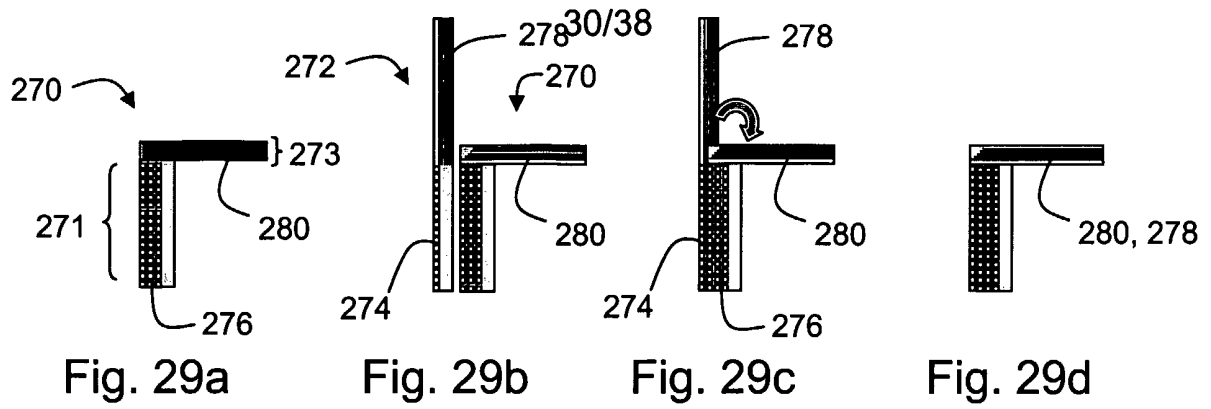
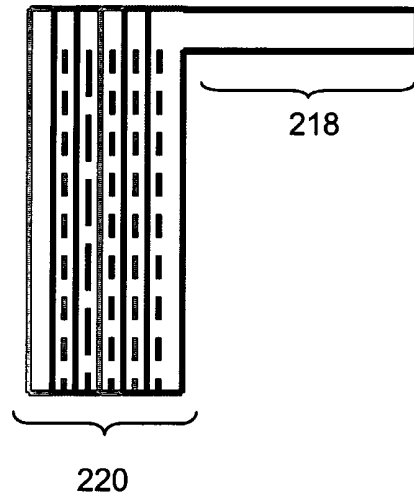

Fig. 29e



31/38

Fig. 30a

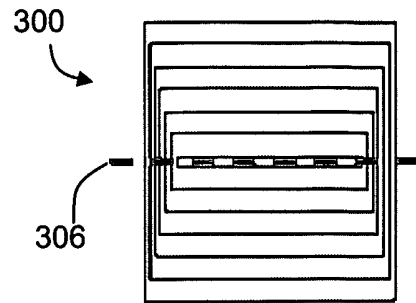
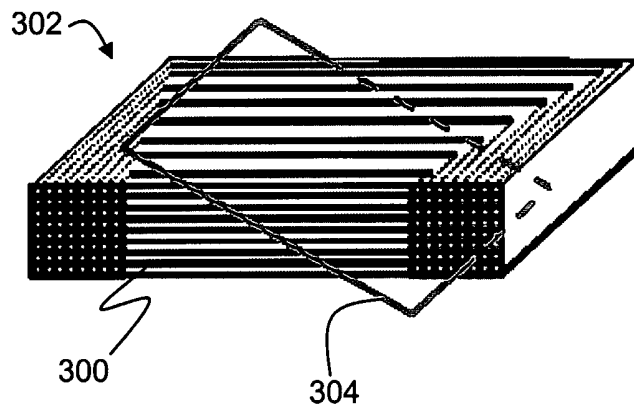

Fig. 30b



32/38

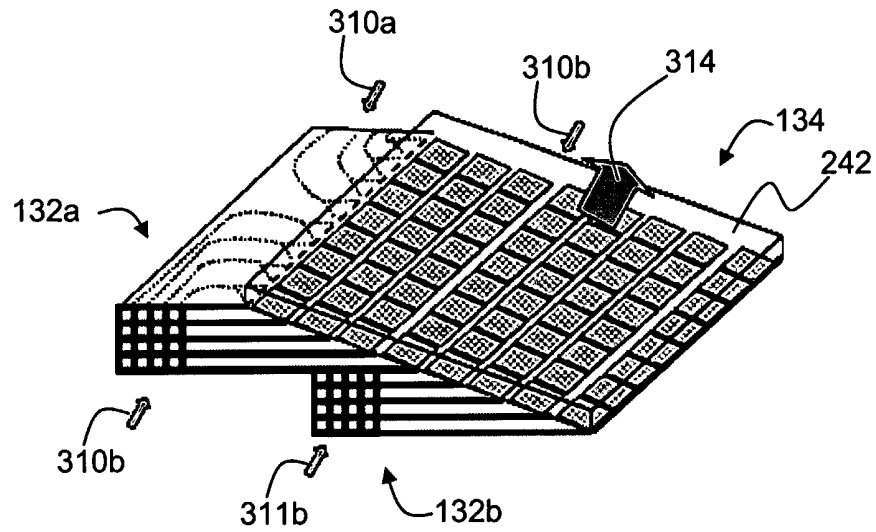

Fig. 31

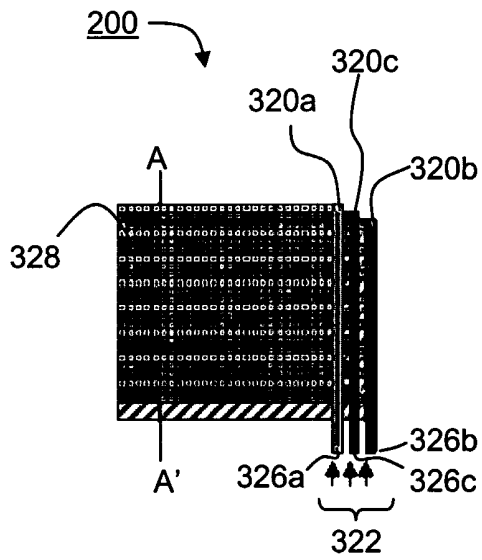

Fig. 32a

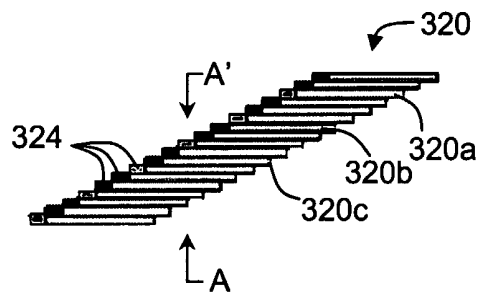

Fig. 32b

33/38

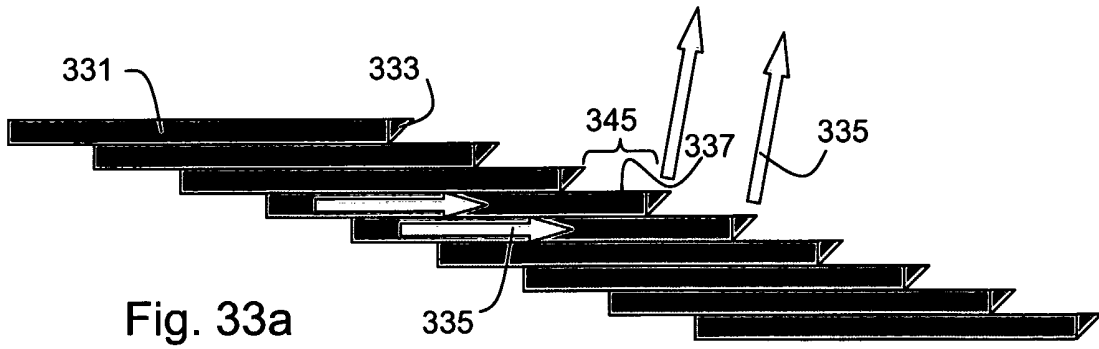

Fig. 33a

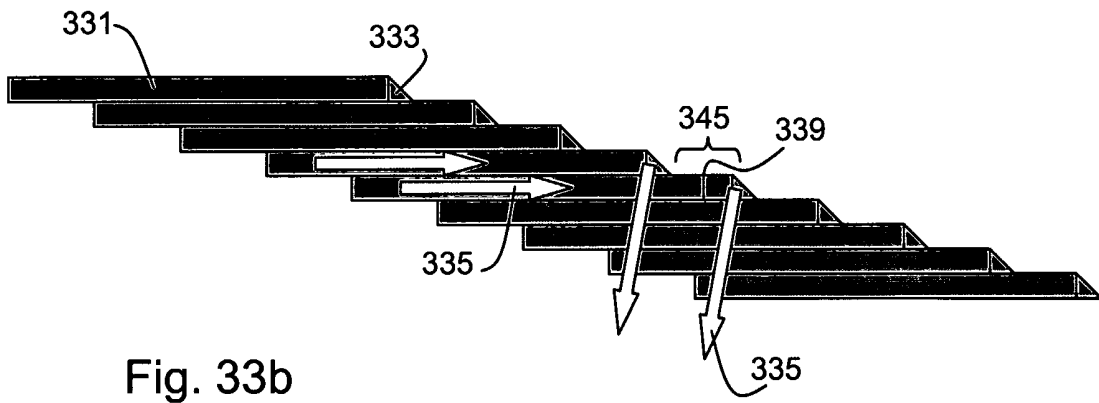

Fig. 33b

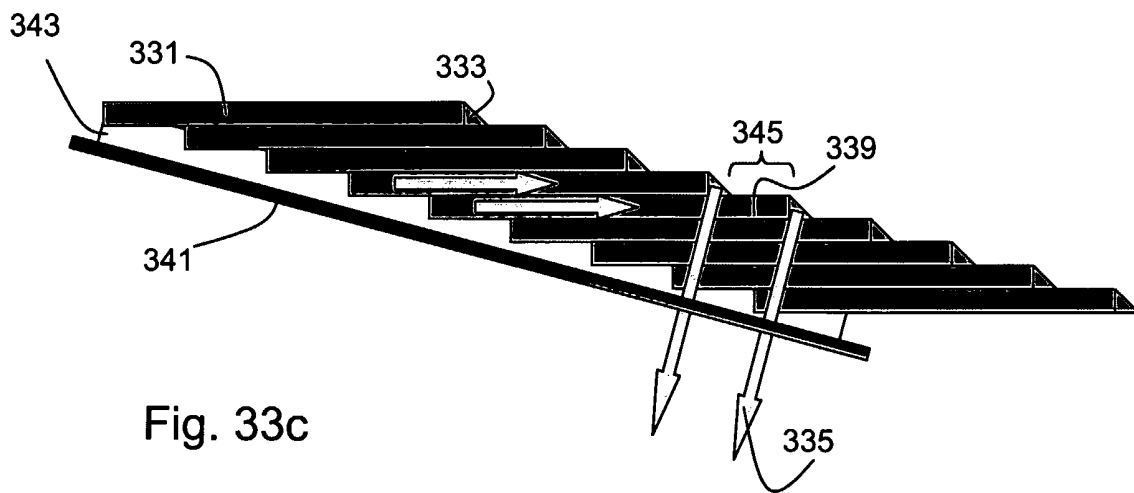

Fig. 33c

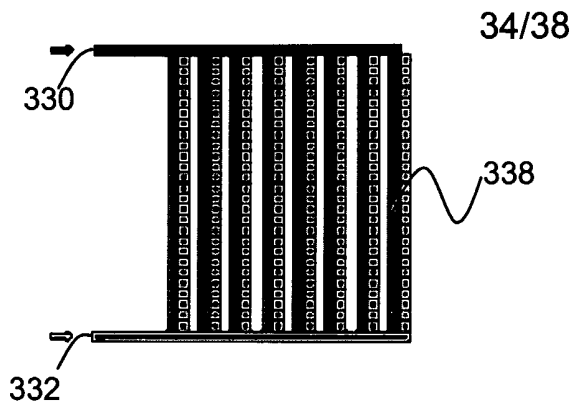

Fig. 34a

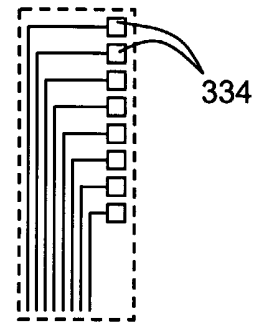

Fig. 34b

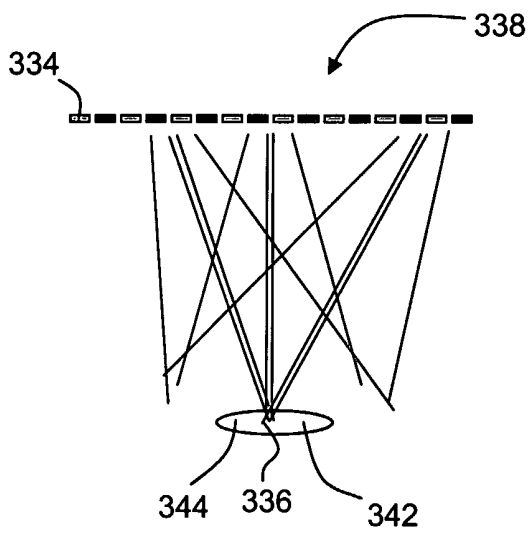

Fig. 34c

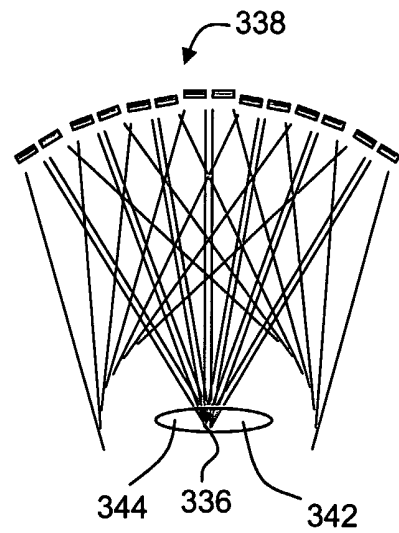

Fig. 34d

35/38

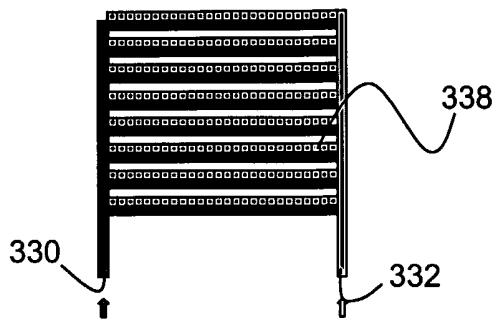

Fig. 35a

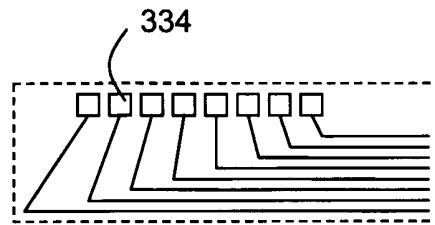

Fig. 35b

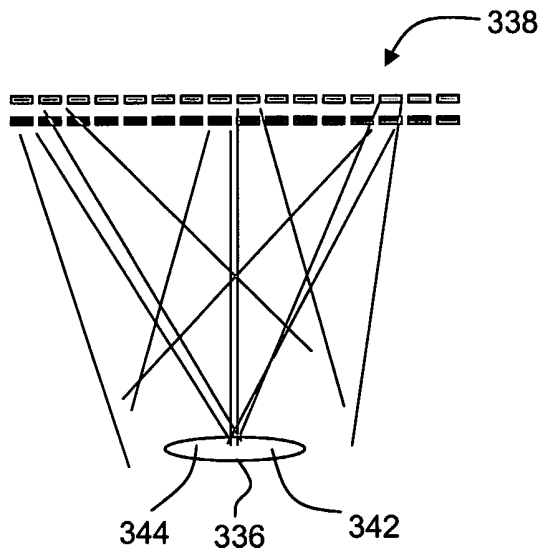

Fig. 35c

36/38

Fig. 36

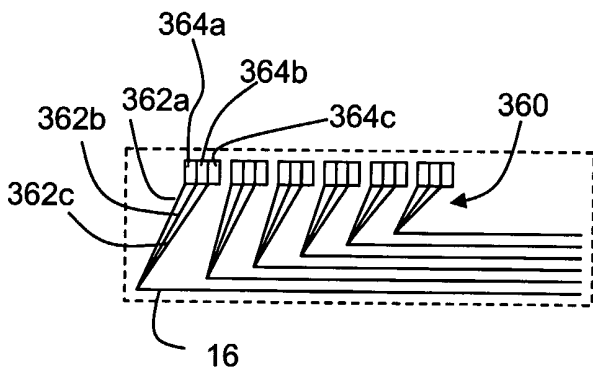
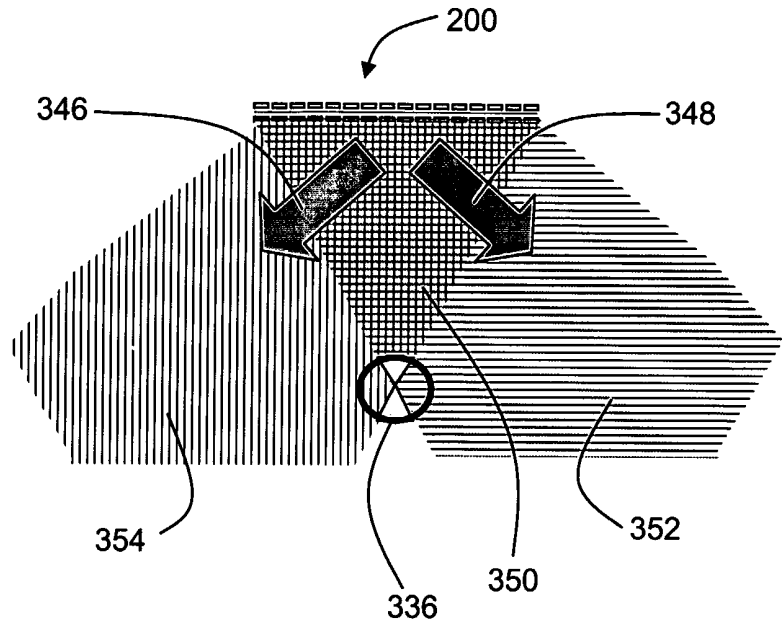

Fig. 37a

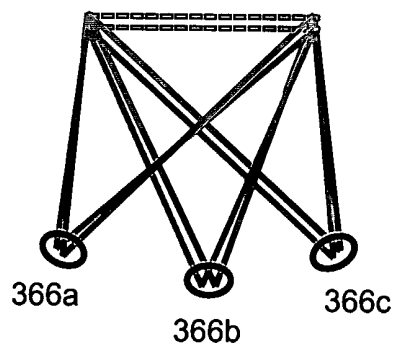

Fig. 37b

Fig. 38

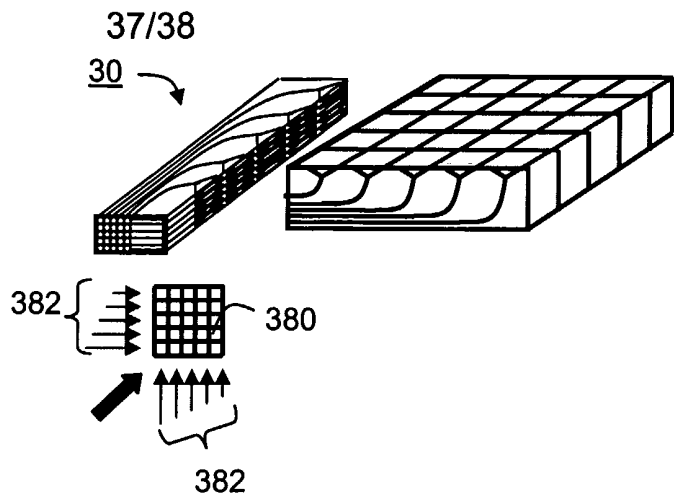

Fig. 39a

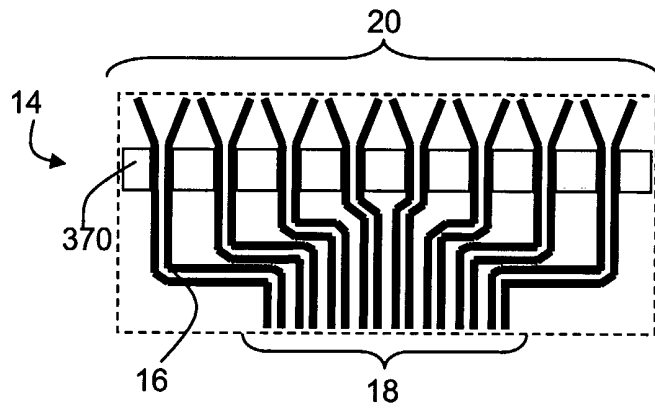

Fig. 39b

