

(19) World Intellectual Property
Organization
International Bureau



(43) International Publication Date
2 December 2004 (02.12.2004)

PCT

(10) International Publication Number
WO 2004/104469 A1

(51) International Patent Classification⁷: **F16L 55/165**

(21) International Application Number:
PCT/DK2004/000366

(22) International Filing Date: 26 May 2004 (26.05.2004)

(25) Filing Language: English

(26) Publication Language: English

(30) Priority Data:
PA 2003 00792 26 May 2003 (26.05.2003) DK

(71) Applicant (for all designated States except US): **INPIPE DANMARK A/S** [DK/DK]; 65 Sjøællandsgade, DK-7100 Vejle (DK).

(72) Inventor; and

(75) Inventor/Applicant (for US only): **RASMUSSEN, Bent** [DK/DK]; 38 Strandvænget, DK-6000 Kolding (DK).

(74) Agent: **CHAS. HUDE A/S**; 33 H.C. Andersens Boulevard, DK-1780 Copenhagen V (DK).

(81) Designated States (unless otherwise indicated, for every kind of national protection available): AE, AG, AL, AM, AT, AU, AZ, BA, BB, BG, BR, BW, BY, BZ, CA, CH, CN, CO, CR, CU, CZ, DE, DK, DM, DZ, EC, EE, EG, ES, FI, GB, GD, GE, GH, GM, HR, HU, ID, IL, IN, IS, JP, KE, KG, KP, KR, KZ, LC, LK, LR, LS, LT, LU, LV, MA, MD, MG, MK, MN, MW, MX, MZ, NA, NI, NO, NZ, OM, PG, PH, PL, PT, RO, RU, SC, SD, SE, SG, SK, SL, SY, TJ, TM, TN, TR, TT, TZ, UA, UG, US, UZ, VC, VN, YU, ZA, ZM, ZW.

(84) Designated States (unless otherwise indicated, for every kind of regional protection available): ARIPO (BW, GH, GM, KE, LS, MW, MZ, NA, SD, SL, SZ, TZ, UG, ZM, ZW), Eurasian (AM, AZ, BY, KG, KZ, MD, RU, TJ, TM), European (AT, BE, BG, CH, CY, CZ, DE, DK, EE, ES, FI, FR, GB, GR, HU, IE, IT, LU, MC, NL, PL, PT, RO, SE, SI, SK, TR), OAPI (BF, BJ, CF, CG, CI, CM, GA, GN, GQ, GW, ML, MR, NE, SN, TD, TG).

Published:
— with international search report

For two-letter codes and other abbreviations, refer to the "Guidance Notes on Codes and Abbreviations" appearing at the beginning of each regular issue of the PCT Gazette.

(54) Title: A LINING DEVICE FOR RENOVATING THE BRANCH LINES OF PIPELINES BY WAY OF EVERSION

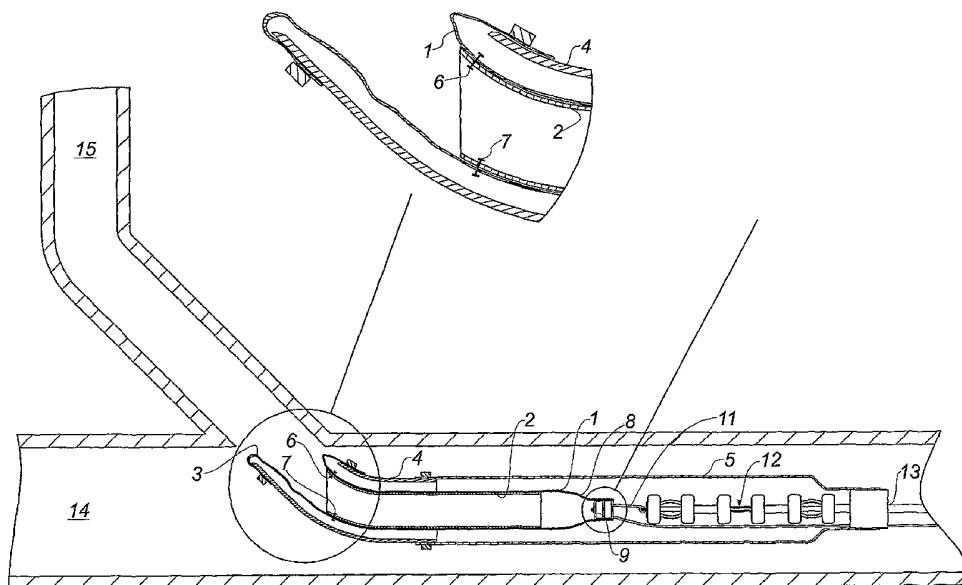

(57) Abstract: A lining device for renovating the branch lines (15) of pipelines (14) by way of eversion includes a hose-shaped outer film (1) and an inner sleeve-shaped expandable reinforcing member (2) adapted to cure when subjected to ultraviolet light. At one end (3), the hose-shaped film (1) is adapted to be secured to the end of a tubular inserting member (4), and at the opposite end it is sealingly secured to a closing member (9). The closing member (9) carries a means (10) for securing a train of UV-lamps (12).

WO 2004/104469 A1

Title: A lining device for renovating the branch lines of pipelines by way of eversion

Technical Field

5 The invention relates to a lining device for renovating the branch lines of pipelines by way of eversion, said lining device including a hose-shaped outer film and an inner sleeve-shaped, expandable reinforcing member adapted to cure when subjected to ultraviolet light, where said hose-shaped film is adapted at one end to be secured to the end of a tubular inserting member, and where said hose-shaped film at the opposite end is sealingly secured to a closing member.

Background Art

15 It is known to renovate short or long lengths of pipelines by means of a lining device in form of a so-called stocking lining. This stocking lining includes a hose-shaped outer film and an inner sleeve-shaped, expandable reinforcing member of a suitable length before it is mounted inside a pipeline. Usually, the reinforcing member includes a reinforcing layer made of fibre glass and a polyester impregnation, as well as an inner film of a suitable plastic material. The lining device is placed inside the pipeline by being inserted into said pipeline by means of compressed air and by way of an eversion in such a manner that the inner film layer faces the pipeline. Subsequently, the reinforcing member is caused to abut the inner side of the pipeline by means of compressed air and then it is caused to cure by means of UV-irradiation.

25 It is relatively easy to carry out such a renovation in subterranean main pipelines extending substantially parallel to streets or roads. However, it is rather difficult to renovate the branch lines connecting the main pipeline to various buildings or vice versa because the access to said branch lines is only allowed through a drain manhole in the main pipeline, said drain manhole being very far from the branch lines to
30 be renovated.

It is known from US Patent No. 6,484,757 to repair a branch line by means of a lining device which includes an outer hose-shaped, expandable film and an inner sleeve-shaped reinforcing member. During the mounting procedure, one end of the lining device is secured to a tubular inserting member which on the outer side comprises an inflatable part at its free end. The lining device is mounted by being inserted with the above end in front into the tubular inserting member and forwards to the free end of said inserting member. Here both the end of the expandable film and the end of the expandable reinforcing member are everted about the end of the inserting member and mounted thereon in such a manner that the end of the sleeve-shaped reinforcing member is placed on the outer side of the inflatable part. The tubular inserting member is then moved into the inlet of a branch line, and subsequently the inflatable part is inflated and causes the end in question of the expandable reinforcing member to abut the inner side of the branch line. Now the entire lining device is blown into the branch line by means of compressed air while continuously being everted and the free end of the lining device being closed by means of a closing member. Finally, the inner sleeve-shaped, expandable reinforcing member has been everted onto the outer side of the film which is now positioned inside said reinforcing member. Subsequently, a continued supply of compressed air presses the remaining portion of the sleeve-shaped reinforcing member outwards and against the inner side of the branch line, where the pressure is maintained until said reinforcing member has cured, such as by being subjected to hot air or steam.

Disclosure of Invention

The object of the invention is to provide a lining device of the above type which is suitable for use in combination with UV-lamps.

The above object is according to the invention obtained by the closing member carrying a means for securing a train of UV-lamps.

30

As a result, a very simple way of inserting UV-lamps into the lining device is ob-

tained, even in case said lining device is placed in a branch line.

According to the invention is it particularly advantageous when the securing means includes a roller for pulling the lamps into the lining device by means of a flexible
5 cord after said lining device has been inserted into a branch line by way of eversion. As a result the lining device can be everted into the branch line without affecting the relatively heavy UV-lamps.

Furthermore, at the end adjacent the end of the outer film which is adapted to be se-
10 cured to the inserting member, the reinforcing member may according to the invention be secured to said end of the outer film by means of fastening means which are adapted to be released from the outer film in connection with a pulling out thereof after the curing of the reinforcement. As a result the sleeve-shaped reinforcing mem-
15 ber is allowed to follow the outer film during the everting movement without necessitating a manual starting of the everting movement of said sleeve-shaped reinforcing member.

Brief Description of the Drawings

20 The invention is explained in detail below with reference to the drawings, in which

Fig. 1 is a sectional view of a lining device according to the invention mounted in an apparatus with an insertion pipe, where the insertion pipe of said apparatus is placed in a main pipe in front of the outlet of a branch line into said main pipe,

25

Figs. 2 and 3 are sectional views on a larger scale of framed portions of Fig. 1,

Fig. 4 corresponds to Figs. 2 and 3, but where the lining device is being inserted into the branch line,

30

Fig. 5 corresponds to Fig. 4, but where the lining device is placed in the branch line

with the sleeve-shaped reinforcing member pressed against the inner side of said branch line by means of compressed air, and where a train of UV-lamps are being pulled into said lining device,

- 5 Fig. 6 corresponds to Fig. 5, but where the train of UV-lamps are switched on while being pulled out of the everted lining device,

Fig. 7 corresponds to Fig. 6, but where the expandable film is being pulled out of the cured reinforcing member, and

10

Fig. 8 corresponds to Fig. 7, but where the expandable film has been completely removed from the mounted sleeve-shaped reinforcing member.

Best Mode for Carrying out the Invention

15

The lining device shown in Figs. 1, 2 and 3 includes an outer hose-shaped, expandable film 1 and an inner sleeve-shaped, expandable reinforcing member 2. One first end 3 of the expandable film 1 is adapted to be mounted on the outer side of an inserting pipe 4, cf. the Figures. The inserting pipe 4 forms a front part of a mounting apparatus 5 of a conventionally known type. This mounting apparatus 5 is adapted to receive the lining device in the interior thereof in order to allow a mounting of said lining device by way of eversion and by means of compressed air, said apparatus being air-tightly sealed in a conventionally known manner and being connected to means (not shown) for feeding compressed air. The end of the sleeve-shaped, expandable reinforcing member 2 adjacent the first end of the expandable film 1 is secured to said outer expandable film 1 by means of a plurality of plastic clips 6, 7. These clips can be of the same type as the one used for fastening price tags to clothes in clothes shops, i.e. H or I-shaped plastic means.

- 20
- 25
- 30 A closing member 9 is provided at the opposite end of the expandable film 1, said closing member 9 closing the end in question in a conventionally known manner so

that the connection is completely sealing. As illustrated in Fig. 3 on a larger scale, the closing member 9 includes a roller or pulley 10 adapted to co-operate with a cord 11. This cord 11 is connected to a train of UV-lamps designated the general reference numeral 12, and the cord 11 leaves the mounting apparatus 5 in a sealing manner so as to be handled from the outside. At the opposite end of the train of UV-lamps, the cord 11 is connected to a cable 13 also sealingly leaving the mounting apparatus and communicating with a source of energy in a manner not shown in greater detail.

10 The mounting apparatus 5 with the lining device mounted as shown in Fig. 1 is moved forwards inside a main pipeline 14 to the inlet of a branch line 15 by means of a remote-controlled robot including a camera in a conventionally known manner. At an approximate position opposite the inlet of the branch line 15, the mounting apparatus is fixed and the mounting procedure is initiated by compressed air being fed
15 into the interior of said mounting apparatus 5. Then the mounting procedure continues as illustrated in Figs. 4 and 5, viz. the lining device passes into said branch line and the inner side of said lining device is everted until the entire sleeve-shaped mounting member has been everted. Then the sleeve-shaped reinforcing member is pressed outwards so as to abut the inner side of the branch line 15 by a feeding of
20 additional compressed air, cf. in particular Fig. 5. When the latter state has been reached, the row 12 of UV-lamps is pulled into the everted lining device in the branch line 15 by means of the cord 11.

As illustrated in the drawing, the end of the sleeve-shaped reinforcing member 2 ultimately positioned adjacent the main pipeline 14 is obliquely cut in accordance with the inclination of the branch line relative to the main pipeline 14.

When the row 12 of UV-lamps has reached the bottom of the lining device inside the branch line 15, the lamps of the row 12 are switched on, cf. Fig. 6, and while said
30 lamps are switched on, the row 12 of lamps is pulled backwards out of the branch line 15 again at a suitable speed by means of the cable 13. As a result, the sleeve-

shaped expanded reinforcing member is subjected to a curing which implies that said reinforcing member remains secured to the inner wall of the branch line 15 in a conventionally known manner.

- 5 Fig. 7 shows the row 12 of lamps in the completely retracted position inside the mounting apparatus 5 while the expandable film 1 is in the process of being pulled off the sleeve-shaped reinforcing member 2 by means of the cord 11.

In Fig. 8, the expandable film 1 has been completely removed from the sleeve-shaped reinforcing member 2. Now the mounting apparatus can be removed from the
10 main pipeline, and possible projecting portions of the sleeve-shaped mounting member 2 can be cut off by means of remote-controlled robots.

The described lining device is suited for mounting in branch lines which extend both
15 perpendicular to the main pipeline and at a relatively acute angle from said main pipeline because the inserting pipe 4 can be placed at such a distance from the inlet to the branch line 15 that the sleeve-shaped reinforcing member 2 is always arranged at the transition between the branch line 15 and the main pipeline 14. The plastic clips 6 and 7 used are of such a type that they can easily be torn loose of the expand-
20 able film 1 during the removal of said film 1 from the mounted reinforcing member 2. However, they must be arranged in such a manner that they ensure that the sleeve-shaped reinforcing member 2 follows the everting process.

A releasable adhesive layer can optionally be placed between the outer expandable
25 film 1 and the sleeve-shaped expandable reinforcing member 2, said adhesive layer facilitating the control of the everting procedure and in addition also the handling of the lining device during the mounting procedure inside the mounting apparatus. Correspondingly, a suitable adhesive layer can be placed on the inner side of the sleeve-shaped reinforcing member 2, said adhesive layer allowing a particularly good re-
30 taining of the sleeve-shaped member 2 on the inner side of the branch line 15 after the everting procedure.

The invention has been described with reference to a preferred embodiment. Many modifications can be carried out without thereby deviating from the scope of the invention.

Claims

1. A lining device for renovating the branch lines (15) of pipelines (14) by way of eversion, said lining device including a hose-shaped outer film (1) and an inner sleeve-shaped, expandable reinforcing member (2) adapted to cure when subjected to ultraviolet light, where said hose-shaped film (1) is adapted at one end to be secured to the end of a tubular inserting member (4), and where said hose-shaped film (1) at the opposite end is sealingly secured to a closing member (9), **characterised in** that the closing member (9) carries a means (10) for securing a train of UV-lamps (12).
2. A lining device according to claim 1, **characterised in** that the securing means (10) includes a roller for pulling the lamps (12) into the lining device by means of a flexible cord (11) after said lining device has been inserted into a branch line (15) by way of eversion.
3. A lining device according to claim 1 or 2, **characterised in** that at least at the end adjacent the end (3) of the outer film (1) which is adapted to be secured to the inserting member (4), the reinforcing member (2) is secured to said end by means of fastening means (6, 7) which are adapted to be released from the outer film (1) in connection with a pulling out thereof after the curing of the reinforcement (2).

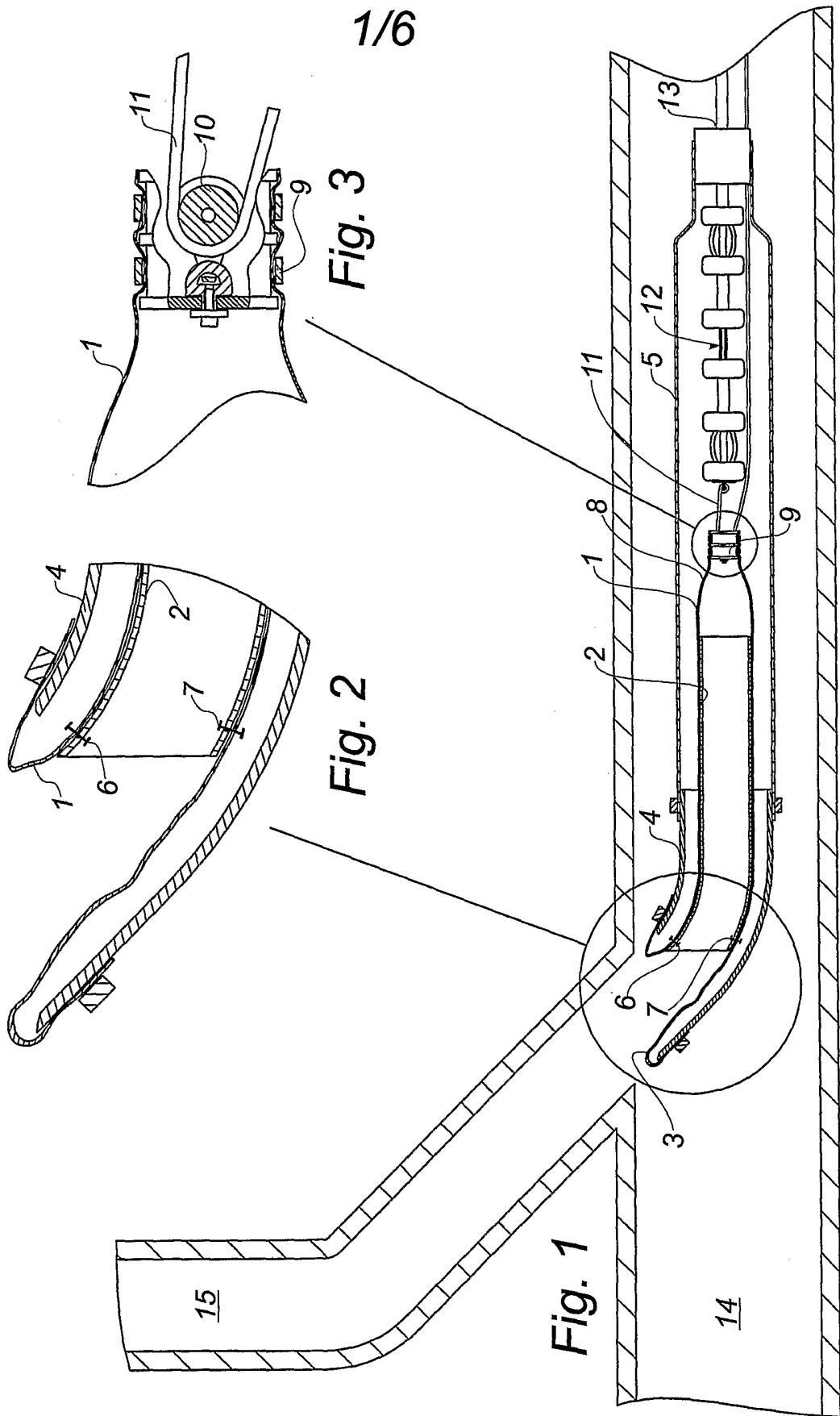

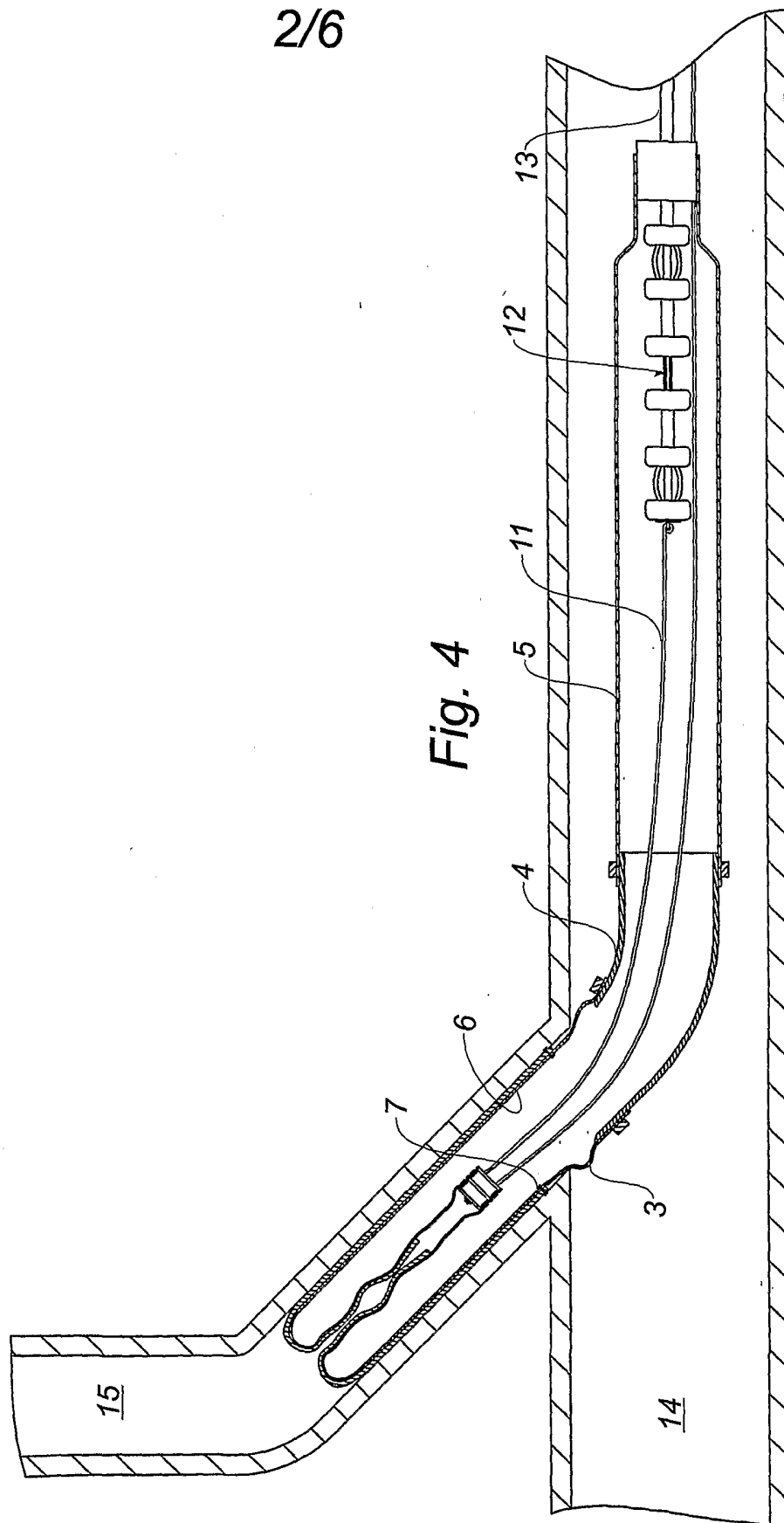

Fig. 4

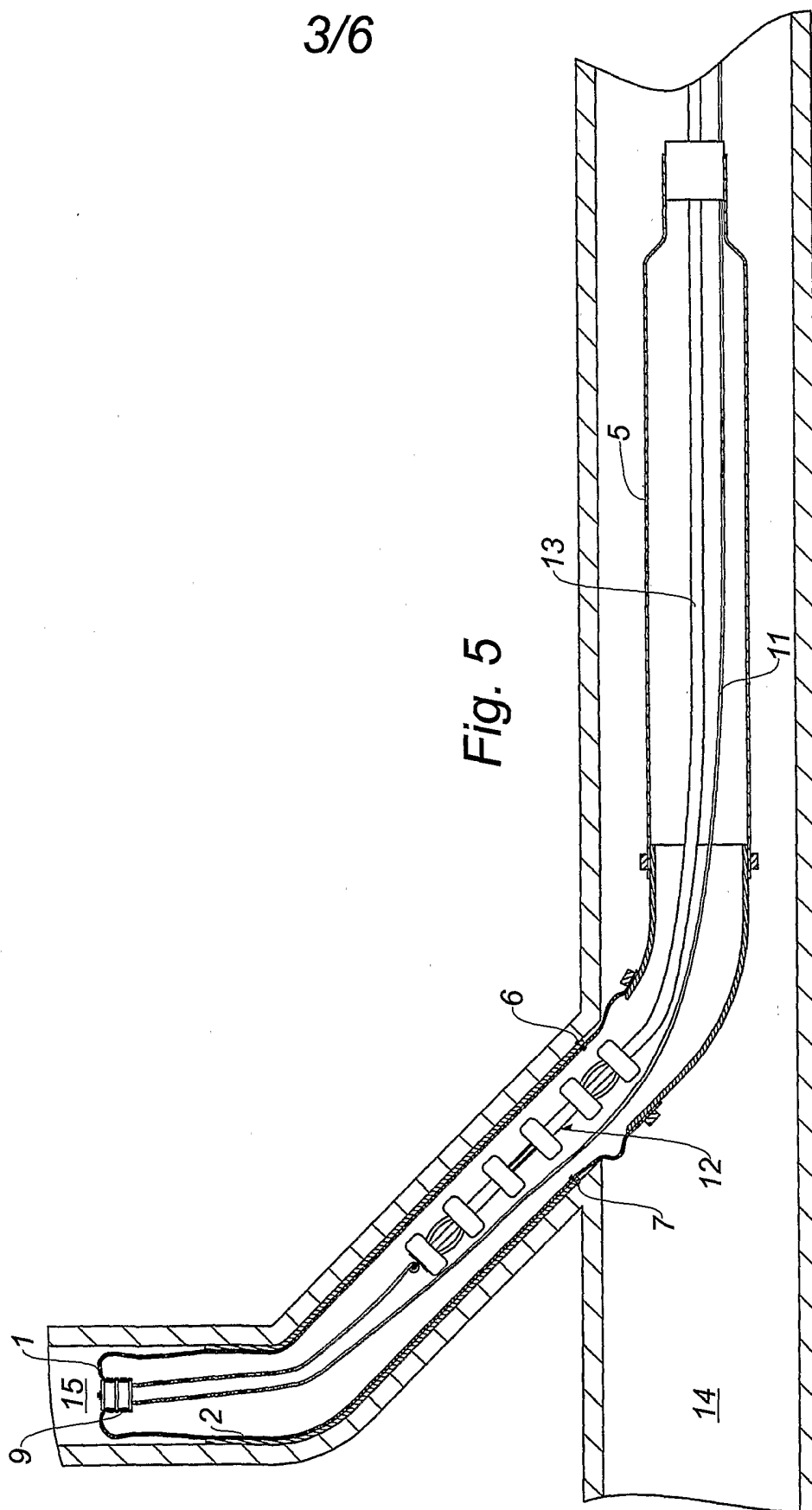

Fig. 5

4/6

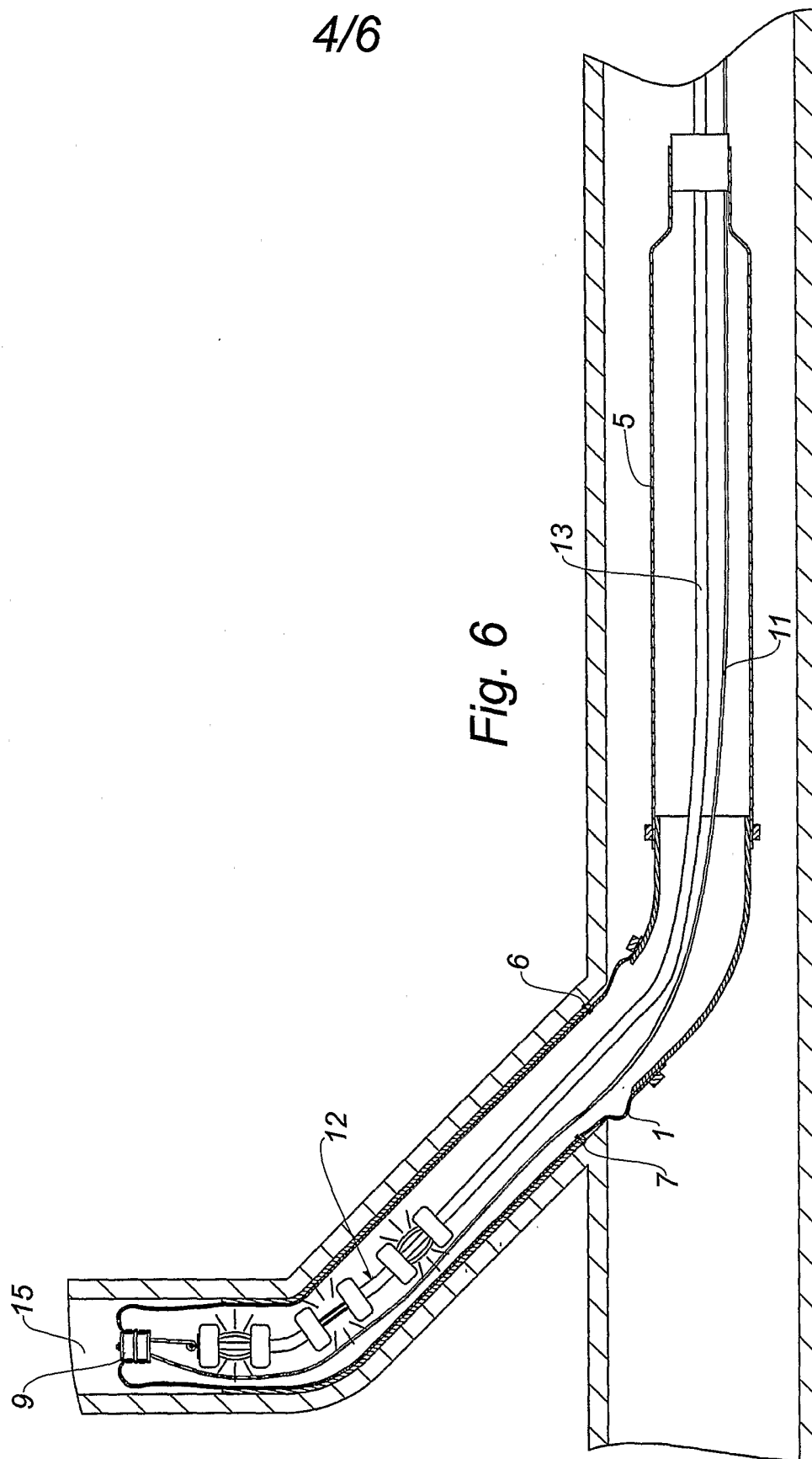

Fig. 6

5/6

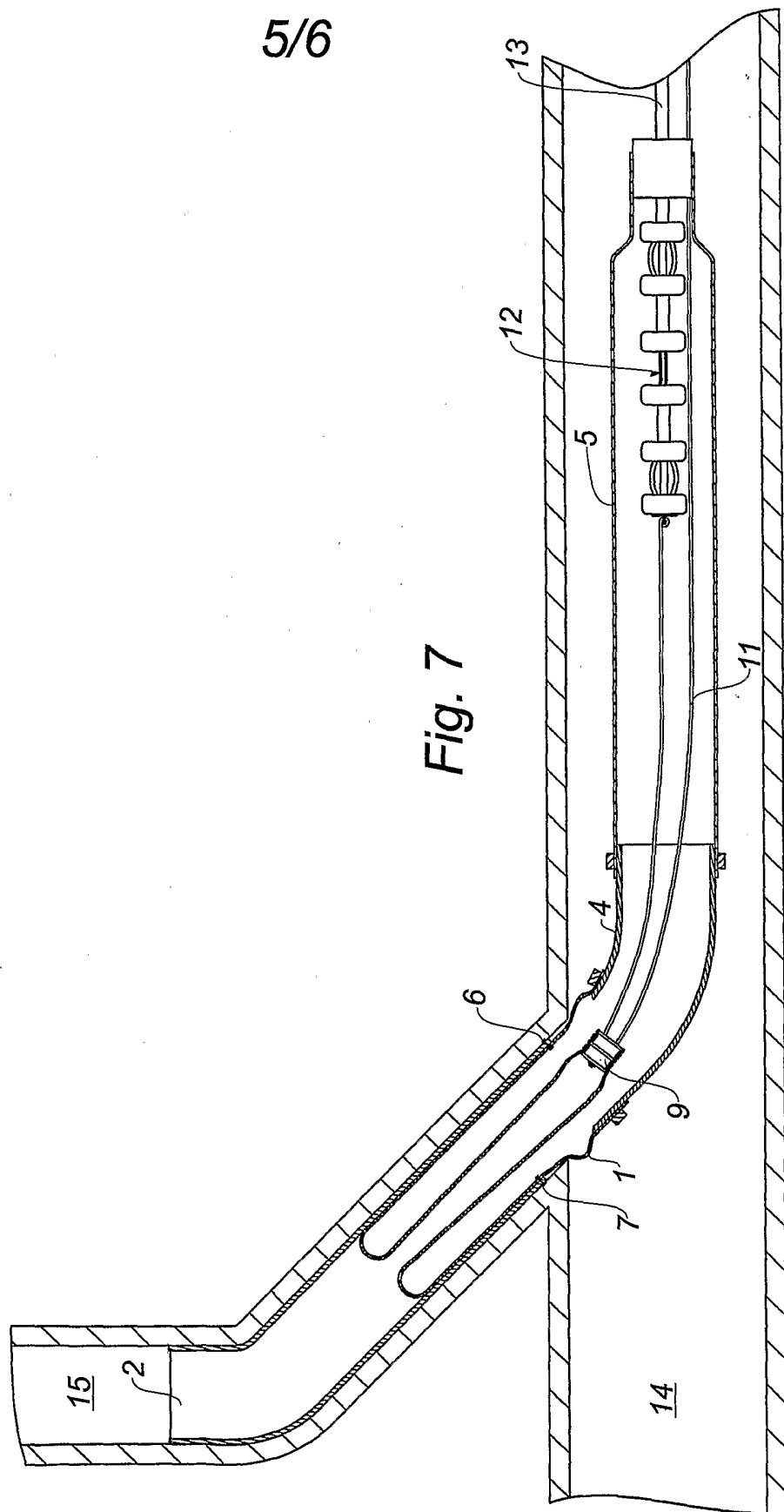

Fig. 7

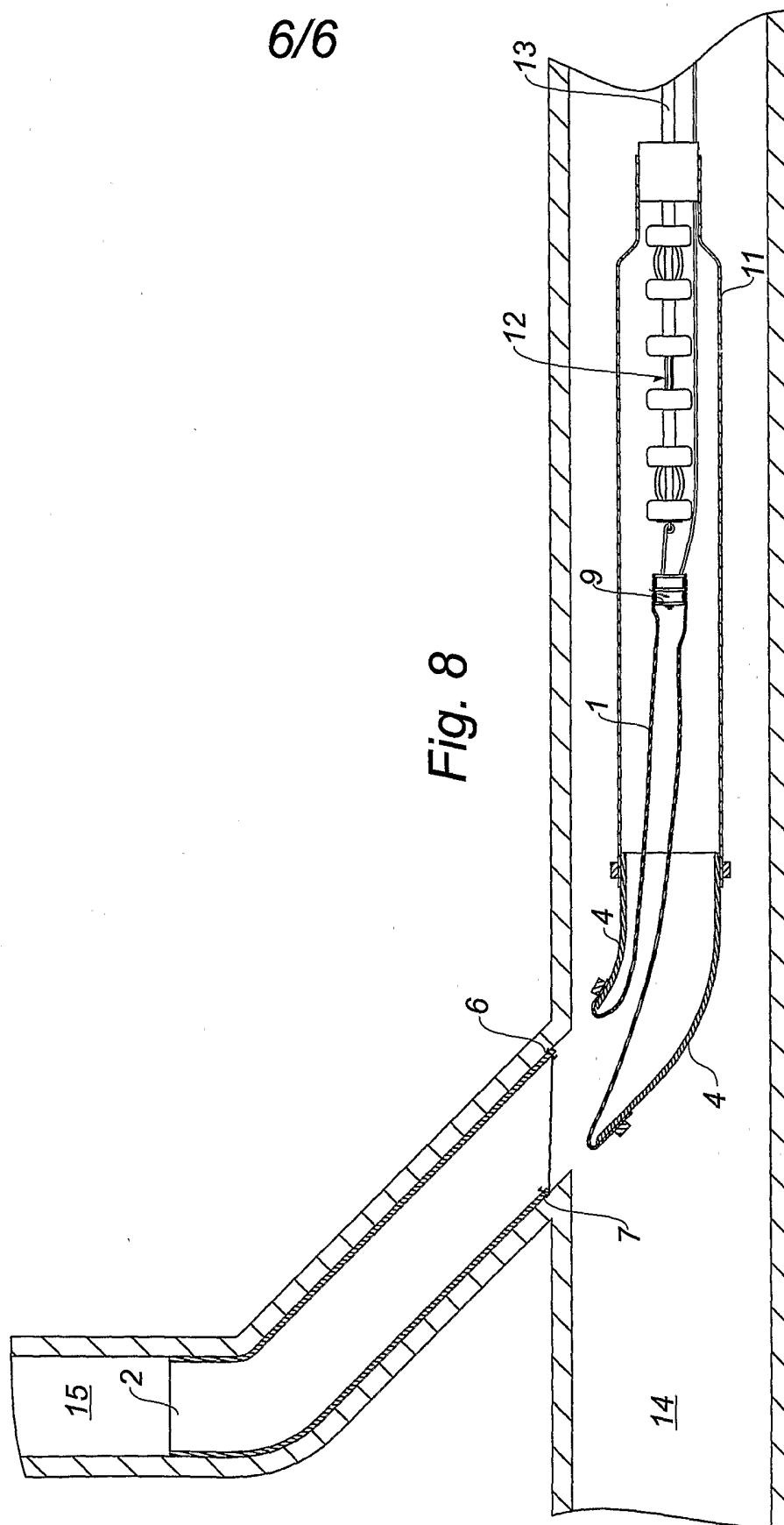

Fig. 8

INTERNATIONAL SEARCH REPORT

International Application No
PCT/DK2004/000366

A. CLASSIFICATION OF SUBJECT MATTER
IPC 7 F16L55/165

According to International Patent Classification (IPC) or to both national classification and IPC

B. FIELDS SEARCHED
Minimum documentation searched (classification system followed by classification symbols)
IPC 7 F16L

Documentation searched other than minimum documentation to the extent that such documents are included in the fields searched

Electronic data base consulted during the international search (name of data base and, where practical, search terms used)
EPO-Internal

C. DOCUMENTS CONSIDERED TO BE RELEVANT

Category °	Citation of document, with indication, where appropriate, of the relevant passages	Relevant to claim No.
X	FR 2 724 004 A (ISOTECH) 1 March 1996 (1996-03-01) abstract; figures 1,2,4 page 5, line 13 - line 18	1,2
X	US 5 950 682 A (KIEST JR LARRY W) 14 September 1999 (1999-09-14) abstract; figures 2,3,7-9,11,12 column 3, line 61 - column 4, line 3	1,3
X	DE 44 26 151 A (KMG MITTE GMBH & CO KG) 25 January 1996 (1996-01-25) abstract; figures 1-5	1
X	DE 201 21 554 U (POLYLINE KANALSANIERUNG GMBH &) 19 December 2002 (2002-12-19) abstract; figure 4	1

Further documents are listed in the continuation of box C. Patent family members are listed in annex.

° Special categories of cited documents:

<p>"A" document defining the general state of the art which is not considered to be of particular relevance</p> <p>"E" earlier document but published on or after the international filing date</p> <p>"L" document which may throw doubts on priority claim(s) or which is cited to establish the publication date of another citation or other special reason (as specified)</p> <p>"O" document referring to an oral disclosure, use, exhibition or other means</p> <p>"P" document published prior to the international filing date but later than the priority date claimed</p>	<p>"T" later document published after the international filing date or priority date and not in conflict with the application but cited to understand the principle or theory underlying the invention</p> <p>"X" document of particular relevance; the claimed invention cannot be considered novel or cannot be considered to involve an inventive step when the document is taken alone</p> <p>"Y" document of particular relevance; the claimed invention cannot be considered to involve an inventive step when the document is combined with one or more other such documents, such combination being obvious to a person skilled in the art.</p> <p>"&" document member of the same patent family</p>
--	--

Date of the actual completion of the international search 21 July 2004	Date of mailing of the international search report 29/07/2004
--	---

Name and mailing address of the ISA European Patent Office, P.B. 5818 Patentlaan 2 NL - 2280 HV Rijswijk Tel. (+31-70) 340-2040, Tx. 31 651 epo nl, Fax: (+31-70) 340-3016	Authorized officer Balzer, R
--	--

INTERNATIONAL SEARCH REPORT

Information on patent family members

International Application No
PCT/DK2004/000366

Patent document cited in search report		Publication date	Patent family member(s)	Publication date
FR 2724004	A	01-03-1996	FR 2724004 A1	01-03-1996
US 5950682	A	14-09-1999	US 5765597 A	16-06-1998
			AU 2621397 A	07-01-1999
			EP 0887584 A1	30-12-1998
			US 2002157784 A1	31-10-2002
			US 6105619 A	22-08-2000
			US 6482280 B1	19-11-2002
			US 6199591 B1	13-03-2001
			US 5794663 A	18-08-1998
			US 6021815 A	08-02-2000
			US 5816293 A	06-10-1998
			US 5964249 A	12-10-1999
			AU 3322395 A	14-03-1996
			CA 2173127 A1	29-02-1996
			WO 9606300 A1	29-02-1996
			US 6206993 B1	27-03-2001
			US 5855729 A	05-01-1999
DE 4426151	A	25-01-1996	DE 4426151 A1	25-01-1996
DE 20121554	U	19-12-2002	DE 20121554 U1	19-12-2002