

G. P. BENNETT.
Vehicle Hub.

No. 198,924.

Patented Jan. 8, 1878.

Fig. 1.

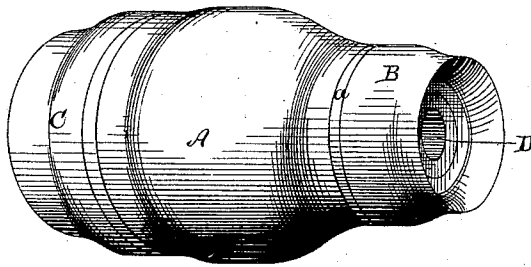
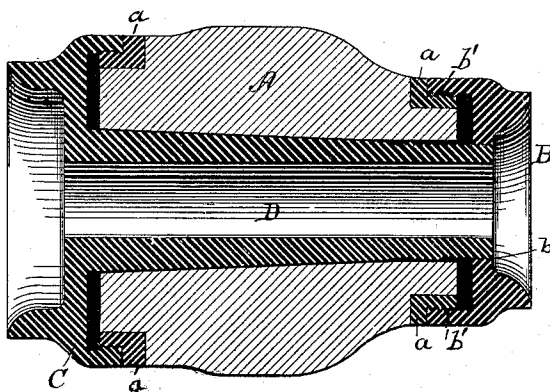

Fig. 2.



WITNESSES:

Clarence Poole
Geo. H. Evans

INVENTOR:

George P. Bennett
per atty.
A. H. Evans & Co.

UNITED STATES PATENT OFFICE.

GEORGE P. BENNETT, OF CORNING, IOWA.

IMPROVEMENT IN VEHICLE-HUBS.

Specification forming part of Letters Patent No. **198,924**, dated January 8, 1878; application filed June 12, 1877.

To all whom it may concern:

Be it known that I, GEORGE P. BENNETT, of Corning, in the county of Adams and State of Iowa, have invented a new and useful Improvement in Hubs, of which the following is a clear, full, and exact description, reference being had to the accompanying drawings, forming a part of this specification, in which—

Figure 1 is a perspective view of a hub with my improvement attached. Fig. 2 is a longitudinal section of the same.

My invention relates to hubs for land-carriages of various kinds; and it consists in the combination of devices hereinafter explained and claimed.

To enable others skilled in the art to make and use my invention, I will proceed to describe the exact manner in which I have carried it out.

In the drawings, A represents a hub, having shrunk upon its outer and inner ends the metal bands *a*, provided with screw-threads. Over the one end is fitted and screwed the metal cap B, which is also provided on its interior with the screw-threads *b b'*.

On the inner or large end of the hub A is fitted the screw-cap C, having cast upon it the elongated box D, which extends entirely

through the hub A, and is provided with a screw-thread upon its outer end, which enters and screws into the threads *b* of the metal cap B, thus binding and firmly drawing together the caps on the opposite ends of the hub.

I am aware of patents to H. A. Payne, No. 158,974, dated January 19, 1875, and L. N. Bewley, No. 168,445, dated October 5, 1875, for improvements in hubs, and such I disclaim, broadly, as my invention; but,

Having thus explained my invention, what I claim as new, and desire to secure by Letters Patent, is—

The improved hub herein described, consisting of the hub A, having the screw-threaded metal bands *a a* shrunk upon its outer ends, screw-cap C, and elongated box D, cast or formed in one piece, with its outer end screw-threaded, and the metal cap B, having interior screw-threads *b b'*, the several parts constructed and relatively arranged as and for the purpose specified.

GEORGE P. BENNETT.

Witnesses:

D. S. SIGLER,
W. O. MITCHELL.